



Chipsmall Limited consists of a professional team with an average of over 10 year of expertise in the distribution of electronic components. Based in Hongkong, we have already established firm and mutual-benefit business relationships with customers from,Europe,America and south Asia,supplying obsolete and hard-to-find components to meet their specific needs.

With the principle of “Quality Parts,Customers Priority,Honest Operation,and Considerate Service”,our business mainly focus on the distribution of electronic components. Line cards we deal with include Microchip,ALPS,ROHM,Xilinx,Pulse,ON,Everlight and Freescale. Main products comprise IC,Modules,Potentiometer,IC Socket,Relay,Connector.Our parts cover such applications as commercial,industrial, and automotives areas.

We are looking forward to setting up business relationship with you and hope to provide you with the best service and solution. Let us make a better world for our industry!



## Contact us

Tel: +86-755-8981 8866 Fax: +86-755-8427 6832

Email & Skype: info@chipsmall.com Web: www.chipsmall.com

Address: A1208, Overseas Decoration Building, #122 Zhenhua RD., Futian, Shenzhen, China



## General Description

The AOZ8304 is a transient voltage suppressor array designed to protect high speed data lines from ESD and lightning.

This device incorporates eight surge rated, low capacitance steering diodes and a TVS in a single package. During transient conditions, the steering diodes direct the transient to either the positive side of the power supply line or to ground. They may be used to meet the ESD immunity requirements of IEC 61000-4-2, Level 4 and IEC 61000-4-5. The TVS diodes provide effective suppression of ESD voltages:  $\pm 24\text{kV}$  (air discharge) and  $\pm 24\text{kV}$  (contact discharge).

The AOZ8304 comes in a Halogen Free and RoHS compliant DFN-10 2.6mm x 2.6mm package and is rated over a  $-40^{\circ}\text{C}$  to  $+85^{\circ}\text{C}$  ambient temperature range. The AOZ8304 is compatible with both lead free and SnPb assembly techniques. The small size, low capacitance and high ESD protection makes it ideal for protecting high speed video and data communication interfaces.

## Features

- ESD protection for high-speed data lines:
  - IEC 61000-4-2, level 4 (ESD) immunity test
  - $\pm 24\text{kV}$  (air discharge) and  $\pm 24\text{kV}$  (contact discharge)
  - IEC 61000-4-4 (EFT) 40A (5/50ns)
  - IEC 61000-4-5 (Lightning) 25A
  - Human Body Model (HBM)  $\pm 30\text{kV}$
- Small package saves board space
- Low insertion loss
- Protects four I/O lines
- Low clamping voltage
- Low operating voltage: 3.3V
- Green product
- Pb-free device

## Applications

- 10/100/1000 Ethernet
- USB 2.0 power and data line protection
- Video graphics cards
- Monitors and flat panel displays
- Digital Video Interface (DVI)
- T1/E1 telecom ports



## Typical Application

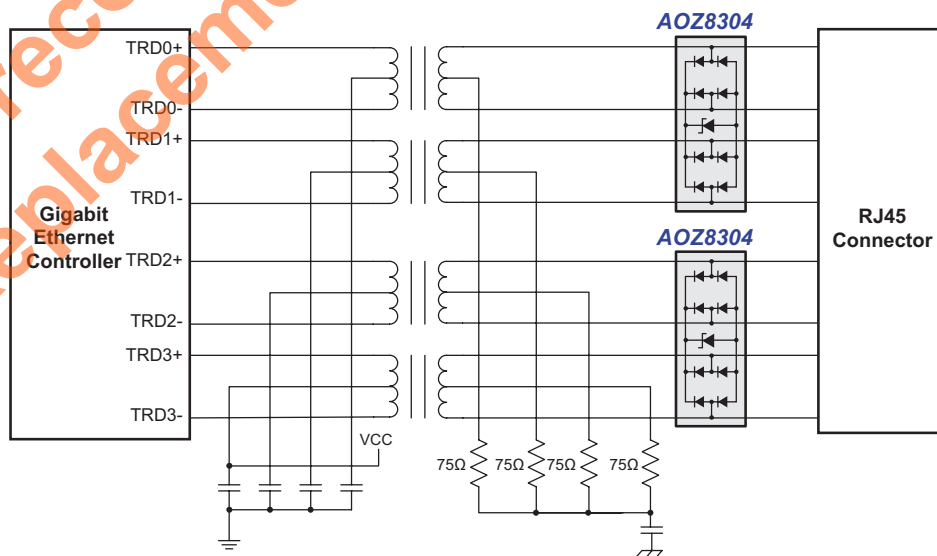

Figure 1. 10/100/1000 Ethernet Port Connection

## Ordering Information

Part Number	Ambient Temperature Range	Package	Environmental
AOZ8304DIL	-40°C to +85°C	2.6mm x 2.6mm DFN-10	RoHS Compliant Green Product



AOS Green Products (with "L" suffix) use reduced levels of Halogens, and are also RoHS compliant.

Please visit [www.aosmd.com/web/quality/rohs\\_compliant.jsp](http://www.aosmd.com/web/quality/rohs_compliant.jsp) for additional information.

## Pin Configuration

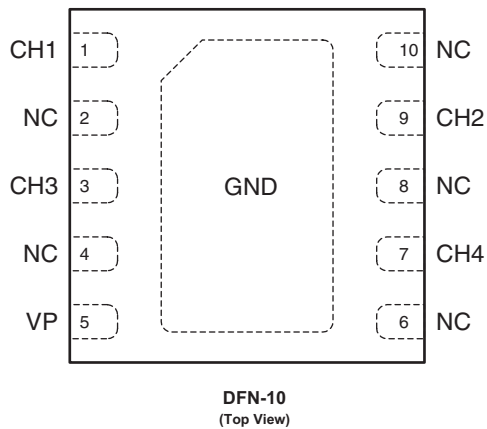

Pin Number	Description
1, 3, 7, 9	Input/Output lines
2, 4, 6, 8, 10	No connection
5	VP
Center Tab	Ground

## Absolute Maximum Ratings

Exceeding the Absolute Maximum ratings may damage the device.

Parameter	Rating
VP – GND	3.3V
Peak Pulse Current ( $I_{PP}$ ), $t_P = 8/20\mu s$	25A
Peak Power Dissipation (8 x 20 $\mu s$ @ 25°C)	350W
Storage Temperature ( $T_S$ )	-65°C to +150°C
ESD Rating per IEC61000-4-2, Contact <sup>(1)</sup>	±24kV
ESD Rating per IEC61000-4-2, Air <sup>(1)</sup>	±24kV
ESD Rating per Human Body Model <sup>(2)</sup>	±30kV

### Notes:

1. IEC 61000-4-2 discharge with  $C_{Discharge} = 150pF$ ,  $R_{Discharge} = 330\Omega$ .

2. Human Body Discharge per MIL-STD-883, Method 3015  $C_{Discharge} = 100pF$ ,  $R_{Discharge} = 1.5k\Omega$ .

## Maximum Operating Ratings

Parameter	Rating
Junction Temperature ( $T_J$ )	-40°C to +85°C



## Electrical Characteristics

$T_A = 25^\circ\text{C}$  unless otherwise specified. Specifications in **BOLD** indicate a temperature range of  $-40^\circ\text{C}$  to  $+85^\circ\text{C}$ .

Symbol	Parameter	Conditions	Min.	Typ.	Max.	Units
$V_{RWM}$	Reverse Working Voltage	Between pin 5 and GND <sup>(4)</sup>			3.3	V
$I_R$	Reverse Leakage Current	$V_{RWM} = 3.3\text{V}$ , between pins 5 and GND			<b>5</b>	$\mu\text{A}$
$V_{BR}$	Reverse Breakdown Voltage	$V_{BR} = 1\text{mA}$	<b>3.5</b>		<b>5.6</b>	V
$V_{CL}$	Channel Clamp Voltage Positive Transients Negative Transient	$I_{PP} = 5\text{A}$ , $t_p = 100\text{ns}$ , any I/O pin to Ground <sup>(3)(6)(8)</sup>			7.00	V
					-4.00	V
	Channel Clamp Voltage Positive Transients Negative Transient	$I_{PP} = 10\text{A}$ , $t_p = 100\text{ns}$ , any I/O pin to Ground <sup>(3)(6)(8)</sup>			9.00	V
					-5.00	V
	Channel Clamp Voltage Positive Transients Negative Transient	$I_{PP} = 25\text{A}$ , $t_p = 100\text{ns}$ , any I/O pin to Ground <sup>(3)(6)(8)</sup>			14.00	V
					-8.00	V
$C_j$	Junction Capacitance	$V_R = 0\text{V}$ , $f = 1\text{MHz}$ , any I/O pin to Ground <sup>(3)(7)</sup> $V_R = 0\text{V}$ , $f = 1\text{MHz}$ , between I/O pins <sup>(3)(7)</sup>		1.25	5	pF pF

### Notes:

3. These specifications are guaranteed by design.
4. The working peak reverse voltage,  $V_{RWM}$ , should be equal to or greater than the DC or continuous peak operating voltage level.
5.  $V_{BR}$  is measured at the pulse test current  $I_T$ .
6. Measurements performed with no external capacitor on VP (pin 5 floating).
7. Measurements performed with VP biased to 3.3 Volts.
8. Measurements performed using a 100ns Transmission Line Pulse (TLP) system.

Not recommended for new designs.  
Replacement part is AOZ8318.

## Typical Performance Characteristics

Typical Variation of  $C_{IN}$  vs.  $V_R$   
( $f = 1\text{MHz}$ ,  $T = 25^\circ\text{C}$ )

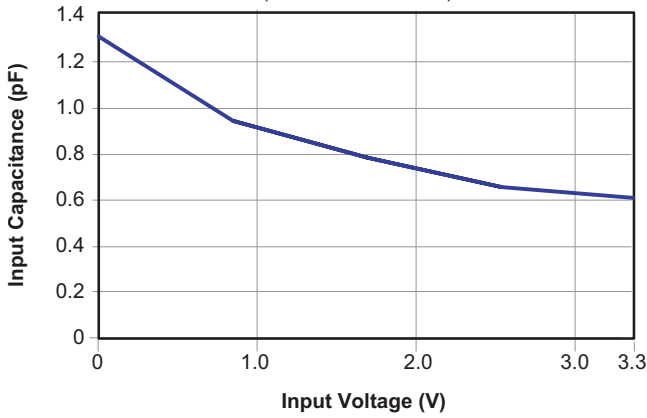

Clamping Voltage vs. Peak Pulse Current  
( $t_{\text{period}} = 100\text{ns}$ ,  $t_r = 1\text{ns}$ )

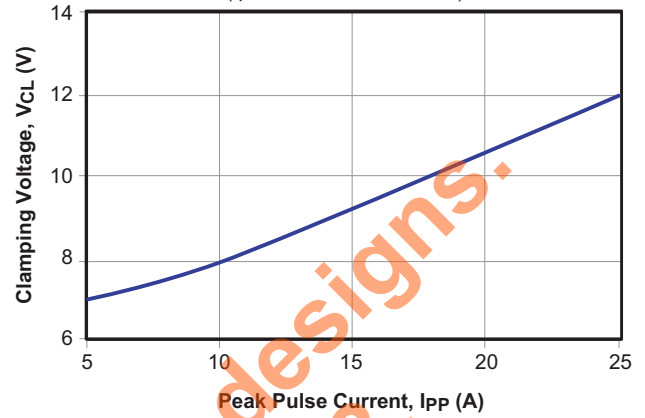

Forward Voltage vs. Forward Current  
( $t_{\text{period}} = 100\text{ns}$ ,  $t_r = 1\text{ns}$ )

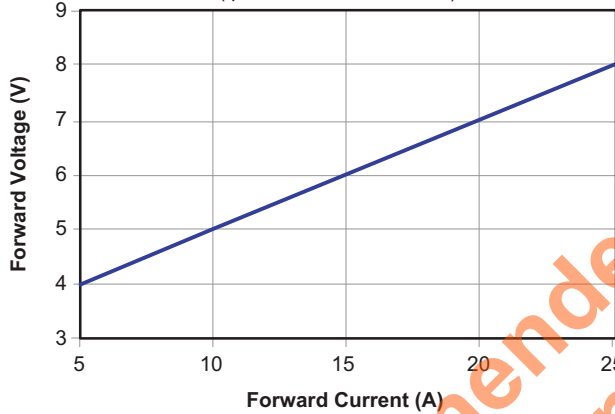

I/O – Gnd Insertion Loss ( $S_{21}$ ) vs. Frequency  
( $V_p = 3.3\text{V}$ )

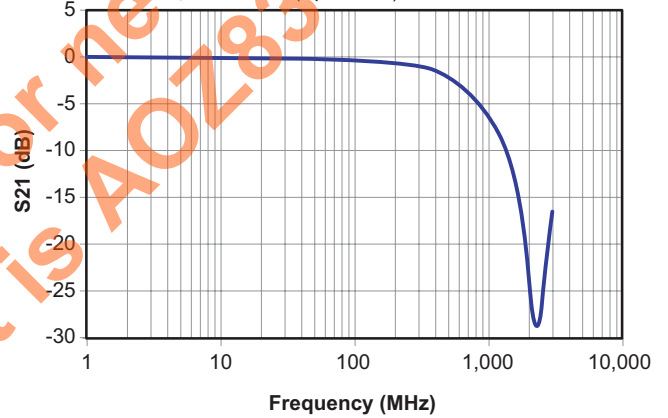

Analog Crosstalk (I/O–I/O) vs. Frequency

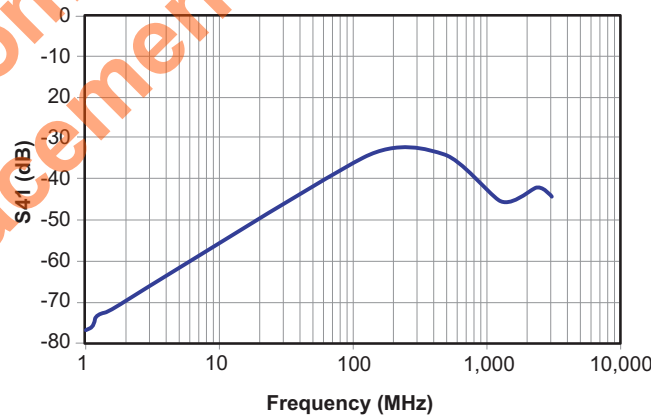

Not recommended for new designs.  
Replacement part is AOZ8318.

## Application Information

The AOZ8304 TVS is design to protect four data lines from fast damaging transient over-voltage by clamping it to a reference. When the transient on a protected data line exceed the reference voltage the steering diode is forward bias thus, conducting the harmful ESD transient away from the sensitive circuitry under protection.

### PCB Layout Guidelines

Printed circuit board layout is the key to achieving the highest level of surge immunity on power and data lines. The location of the protection devices on the PCB is the simplest and most important design rule to follow. The AOZ8304 devices should be located as close as possible to the noise source. The placement of the AOZ8304 devices should be used on all data and power lines that enter or exit the PCB at the I/O connector. In most systems, surge pulses occur on data and power lines that enter the PCB through the I/O connector. Placing the AOZ8304 devices as close as possible to the noise source ensures that a surge voltage will be clamped before the pulse can be coupled into adjacent PCB traces. In addition, the PCB should use the shortest possible traces. A short trace length equates to low impedance, which ensures that the surge energy will be dissipated by the AOZ8304 device. Long signal traces will act as antennas to receive energy from fields that are produced by the ESD pulse. By keeping line lengths as short as possible, the efficiency of the line to act as an antenna for ESD related fields is reduced. Minimize interconnecting line lengths by placing devices with the most interconnect as close together as possible. The protection circuits should shunt the surge voltage to either the reference or chassis ground. Shunting the surge voltage directly to the IC's signal ground can cause ground bounce. The clamping performance of TVS diodes on a single ground PCB can be improved by minimizing the impedance with relatively short and wide ground traces. The PCB layout and IC package parasitic inductances can cause significant overshoot to the TVS's clamping voltage. The inductance of the PCB can be reduced by using short trace lengths and multiple layers

with separate ground and power planes. One effective method to minimize loop problems is to incorporate a ground plane in the PCB design. The AOZ8304 low capacitance TVS is designed to protect four high speed data transmission lines from transient over-voltages by clamping them to a fixed reference. The low inductance and construction minimizes voltage overshoot during high current surges. When the voltage on the protected line exceeds the reference voltage the internal steering diodes are forward biased, conducting the transient current away from the sensitive circuitry.

Good circuit board layout is critical for the suppression of ESD induced transients. The following guidelines are recommended:

1. Place the TVS near the I/O terminals or connectors to restrict transient coupling.
2. Fill unused portions of the PCB with ground plane.
3. Minimize the path length between the TVS and the protected line.
4. Minimize all conductive loops including power and ground loops.
5. The ESD transient return path to ground should be kept as short as possible.
6. Never run critical signals near board edges.
7. Use ground planes whenever possible.
8. Avoid running critical signal traces (clocks, resets, etc.) near PCB edges.
9. Separate chassis ground traces from components and signal traces by at least 4mm.
10. Keep the chassis ground trace length-to-width ratio <5:1 to minimize inductance.
11. Protect all external connections with TVS diodes.

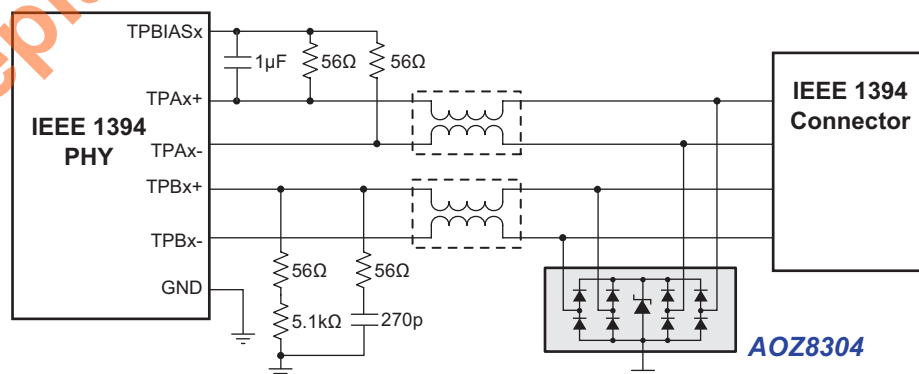

IEEE1394 Port Connection

Package Dimensions, DFN 2.6mm x 2.6mm

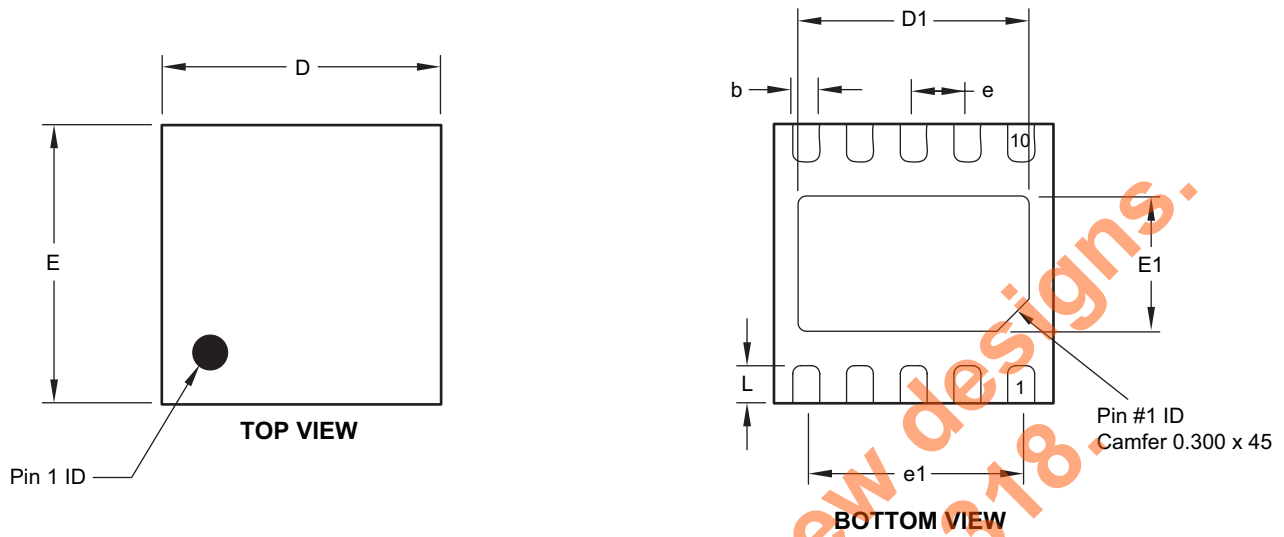

Dimensions in millimeters

Symbols	Min.	Nom.	Max.
A	0.50	0.55	0.60
A1	0.00	0.02	0.05
b	0.22	0.25	0.28
c	0.152 REF		
D	2.55	2.60	2.65
D1	2.10	2.150	2.20
E	2.55	2.60	2.65
E1	1.25	1.26	1.27
e	0.50 BSC		
e1	2.00 REF		
L	0.30	0.35	0.40

Notes:

1. Dimensions and tolerancing conform to ASME Y14.5M-1994.
2. All dimensions are in millimeters.

Tape and Reel Dimensions, DFN 2.6mm x 2.6mm

Carrier Tape

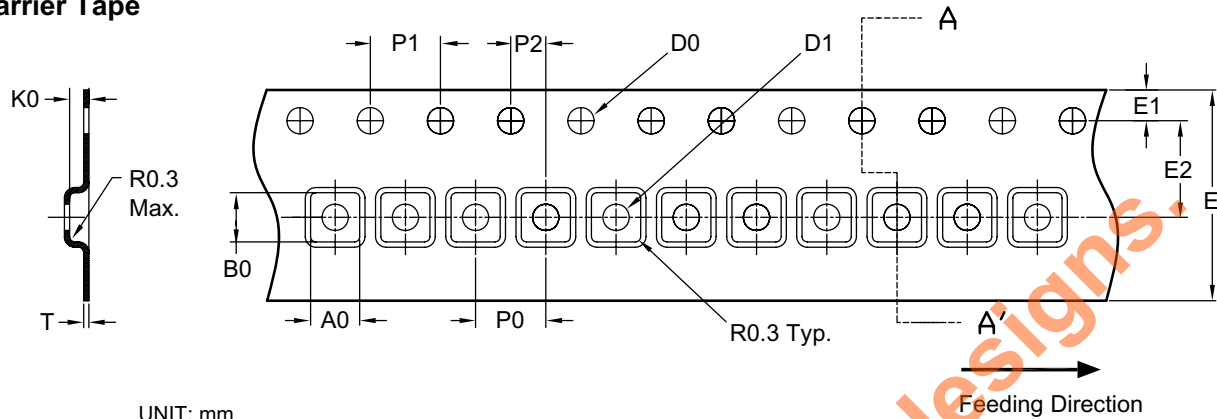

UNIT: mm

Package	T	B0	A0	K0	D0	D1	E	E1	E2	P0	P1	P2
DFN 2.6x2.6	0.30 ±0.05	2.80 ±0.10	2.80 ±0.10	1.10 ±0.10	ø1.50 +0.1/-0.0	ø1.50 Min.	12.0 ±0.3	1.75 ±0.10	5.50 ±0.05	4.00 ±0.10	4.00 ±0.10	2.00 ±0.05

Reel

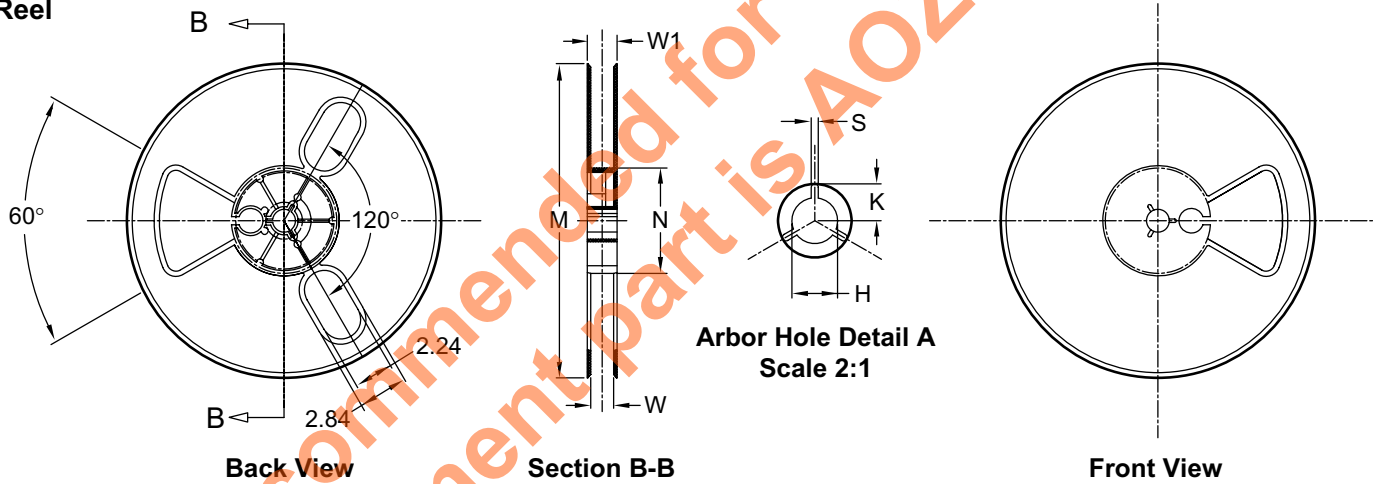

UNIT: mm

Tape Size	Reel Size	M	N	W	W1	H	K	S
12mm	ø180	ø179 ±1.0	60 ±0.5	13 ±0.5	17.0	ø13.0 ±0.2	10.5 ±0.25	2.0 ±0.2

Leader / Trailer & Orientation

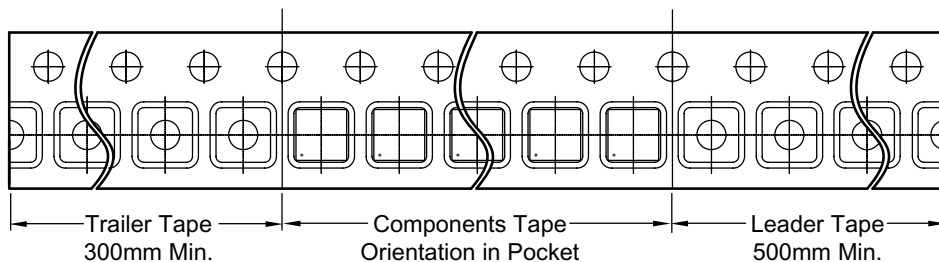



## Part Marking

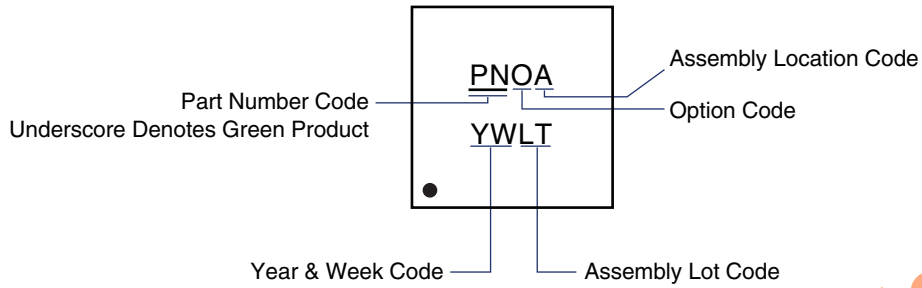

**This datasheet contains preliminary data; supplementary data may be published at a later date. Alpha & Omega Semiconductor reserves the right to make changes at any time without notice.**

### LIFE SUPPORT POLICY

ALPHA & OMEGA SEMICONDUCTOR PRODUCTS ARE NOT AUTHORIZED FOR USE AS CRITICAL COMPONENTS IN LIFE SUPPORT DEVICES OR SYSTEMS.

As used herein:

1. Life support devices or systems are devices or systems which, (a) are intended for surgical implant into the body or (b) support or sustain life, and (c) whose failure to perform when properly used in accordance with instructions for use provided in the labeling, can be reasonably expected to result in a significant injury of the user.
2. A critical component in any component of a life support, device, or system whose failure to perform can be reasonably expected to cause the failure of the life support device or system, or to affect its safety or effectiveness.