



Chipsmall Limited consists of a professional team with an average of over 10 year of expertise in the distribution of electronic components. Based in Hongkong, we have already established firm and mutual-benefit business relationships with customers from,Europe,America and south Asia,supplying obsolete and hard-to-find components to meet their specific needs.

With the principle of “Quality Parts,Customers Priority,Honest Operation,and Considerate Service”,our business mainly focus on the distribution of electronic components. Line cards we deal with include Microchip,ALPS,ROHM,Xilinx,Pulse,ON,Everlight and Freescale. Main products comprise IC,Modules,Potentiometer,IC Socket,Relay,Connector.Our parts cover such applications as commercial,industrial, and automotives areas.

We are looking forward to setting up business relationship with you and hope to provide you with the best service and solution. Let us make a better world for our industry!



## Contact us

Tel: +86-755-8981 8866 Fax: +86-755-8427 6832

Email & Skype: info@chipsmall.com Web: www.chipsmall.com

Address: A1208, Overseas Decoration Building, #122 Zhenhua RD., Futian, Shenzhen, China



# PCS3P25811, PCS3P25812, PCS3P25814



ON Semiconductor®

[www.onsemi.com](http://www.onsemi.com)

## Spread Spectrum Clock Generator

### Product Description

The PCS3P25811/12/14 devices are versatile spread spectrum frequency modulators designed specifically for a wide range of input clock frequencies from 4 MHz to 32 MHz.

The PCS3P25811/12/14 reduce electromagnetic interference (EMI) at the clock source, allowing system wide reduction of EMI of down stream clock and data dependent signals. It allows significant system cost savings by reducing the number of circuit board layers, ferrite beads, shielding, and other passive components that are traditionally required to pass EMI regulations.

The PCS3P25811/12/14 can generate an EMI reduced clock from crystal, ceramic resonator, or system clock.

The PCS3P25811/12/14 modulate the output of a single PLL in order to “spread” the bandwidth of a synthesized clock, and more importantly, decreases the peak amplitudes of its harmonics. This results in significantly lower system EMI compared to the typical narrow band signal produced by oscillators and most frequency generators. Lowering EMI by increasing a signal’s bandwidth is called ‘spread spectrum clock generation’.

The PCS3P25811/12/14 use the most efficient and optimized modulation profile approved by the FCC and is implemented in a proprietary all-digital method.

The PCS3P25811/12/14 have 2 pins S0 and S1 to control the selection of Center Spread, Down Spread and No-Spread functions. Additionally there is a 3 level logic control FSEL, for selecting one of the three different frequency ranges within the operating frequency range. Refer *Input/Output Frequency Range Selection Table*.

The PCS3P25811/12/14 operate from a 2.8 V to 3.6 V supply and are available in 8 pin SOIC, and 8L 2 mm x 2 mm WDFN packages.

### Applications

The PCS3P25811/12/14 are targeted towards EMI management in applications such as LCD Panels, MFPs, Digital copiers, Networking, PC peripheral devices, consumer electronics, and embedded controller systems.

### Features

- Generates a 1x (PCS3P25811), 2x (PCS3P25812) and 4x (PCS3P25814) Low EMI Spread Spectrum Clock of the Input Frequency
- Provides up to 15 dB of EMI Suppression
- Input Frequency: 4 MHz – 32 MHz
- Output Frequency: PCS3P25811: 4 MHz – 32 MHz  
PCS3P25812: 8 MHz – 64 MHz  
PCS3P25814: 16 MHz – 128 MHz

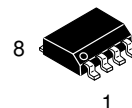

SOIC-8 NB  
CASE 751

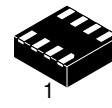

WDFN8 2x2, 0.5P  
CASE 511AQ

### PIN CONFIGURATION

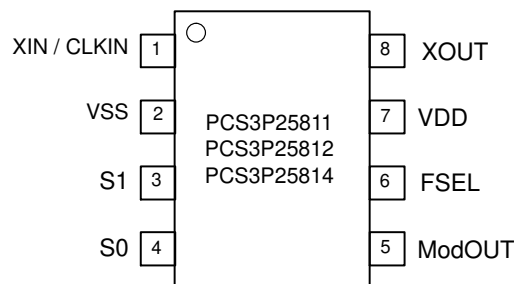

### ORDERING INFORMATION

See detailed ordering and shipping information in the package dimensions section on page 9 of this data sheet.

- Selectable Spread Options: Down Spread and Center Spread
- Low Power Dissipation: 3.3 V: 20 mW (typ) @ 6 MHz  
3.3 V: 24 mW (typ) @ 12 MHz  
3.3 V: 30 mW (typ) @ 24 MHz
- Low Inherent Cycle-to-Cycle Jitter
- Supply Voltage: 2.8 V to 3.6 V
- LVCMOS Input and Output
- Functional and Pinout Compatible to Cypress CY25811, CY25812 and CY25814
- 8-pin SOIC, and 8L 2 mm x 2 mm WDFN (TDFN) Packages
- These Devices are Pb-Free, Halogen Free/BFR Free and are RoHS Compliant

# PCS3P25811, PCS3P25812, PCS3P25814

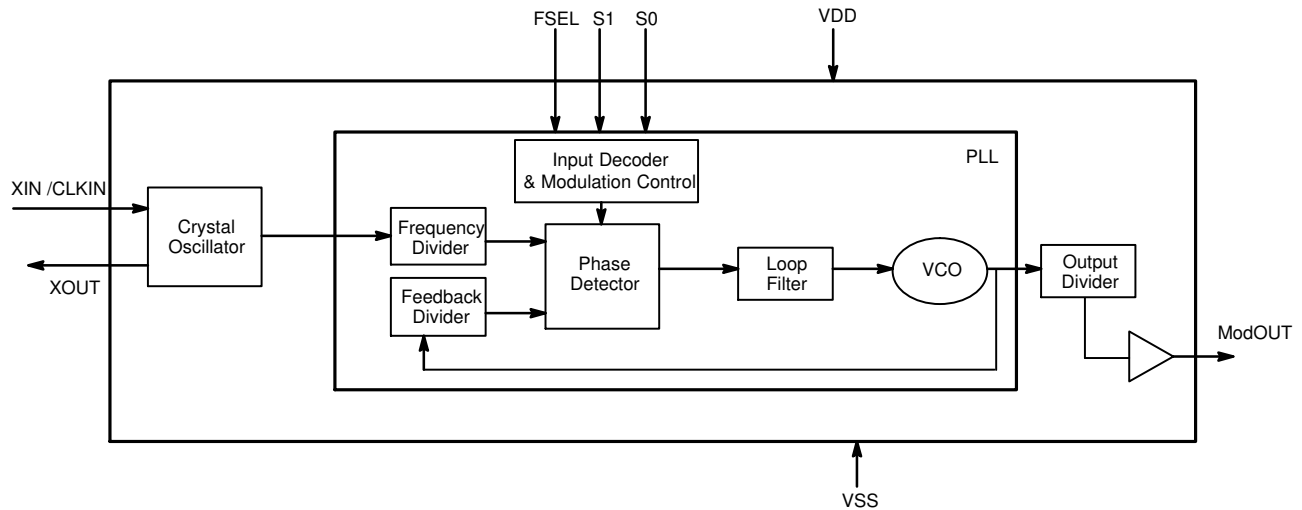

**Figure 1. Block Diagram**

**Table 1. PIN DESCRIPTION**

Pin #	Pin Name	Type	Description
1	XIN / CLKIN	Input	Crystal connection or External Clock input.
2	VSS	Power	Ground to entire chip.
3	S1	Input	Digital 3 level logic input (1–M–0) used to select Center, Down and No spread options. (Refer to <i>Frequency Deviation Selection Table</i> ). Default = M.
4	S0	Input	Digital 3 level logic input (1–M–0) used to select Center, Down and No spread options. (Refer to <i>Frequency Deviation Selection Table</i> ). Default = M.
5	ModOUT	Output	Spread Spectrum Clock Output.
6	FSEL	Input	Frequency range select. Digital 3 level logic input (1–M–0) used to select Input Clock frequency range (Refer to <i>Input/Output Frequency Range Selection Table</i> ). Default = M.
7	VDD	Power	Power supply for the entire chip (2.8 V to 3.6 V).
8	XOUT	Output	Crystal connection. If using an external reference, this pin must be left unconnected.

**Table 2. OUTPUT FREQUENCY RANGE SELECTION**

FSEL (pin 6)	Part Number						Modulation Rate
	PCS3P25811 (1x)		PCS3P25812 (2x)		PCS3P25814 (4x)		
	Input (MHz)	Output (MHz)	Input (MHz)	Output (MHz)	Input (MHz)	Output (MHz)	
0	4 – 8	4 – 8	4 – 8	8 – 16	4 – 8	16 – 32	Input Frequency / 128
1	8 – 16	8 – 16	8 – 16	16 – 32	8 – 16	32 – 64	Input Frequency / 256
M	16 – 32	16 – 32	16 – 32	32 – 64	16 – 32	64 – 128	Input Frequency / 512



**Table 3. OUTPUT FREQUENCY DEVIATION SELECTION**

CLKIN (MHz)	FSEL	S1 = 0 S0 = 0	S1 = 0 S0 = M	S1 = 0 S0 = 1	S1 = M S0 = 0	S1 = 1 S0 = 1	S1 = 1 S0 = 0	S1 = M S0 = 1	S1 = 1 S0 = M	S1 = M S0 = M
		Center	Center	Center	Center	Down	Down	Down	Down	No Spread
4 – 5	0	±1.4	±1.2	±0.6	±0.5	-3	-2.2	-1.9	-0.7	0
5 – 6	0	±1.3	±1.1	±0.5	±0.4	-2.7	-1.9	-1.7	-0.6	0
6 – 7	0	±1.2	±0.9	±0.5	±0.4	-2.5	-1.8	-1.5	-0.6	0
7 – 8	0	±1.1	±0.9	±0.4	±0.3	-2.3	-1.7	-1.4	-0.5	0
8 – 10	1	±1.4	±1.2	±0.6	±0.5	-3	-2.2	-1.9	-0.7	0
10 – 12	1	±1.3	±1.1	±0.5	±0.4	-2.7	-1.9	-1.7	-0.6	0
12 – 14	1	±1.2	±0.9	±0.5	±0.4	-2.5	-1.8	-1.5	-0.6	0
14 – 16	1	±1.1	±0.9	±0.4	±0.3	-2.3	-1.7	-1.4	-0.5	0
16 – 20	M	±1.4	±1.2	±0.6	±0.5	-3	-2.2	-1.9	-0.7	0
20 – 24	M	±1.3	±1.1	±0.5	±0.4	-2.7	-1.9	-1.7	-0.6	0
24 – 28	M	±1.2	±0.9	±0.5	±0.4	-2.5	-1.8	-1.5	-0.6	0
28 – 32	M	±1.1	±0.9	±0.4	±0.3	-2.3	-1.7	-1.4	-0.5	0

NOTE: Device will meet the specifications after thermal equilibrium has been established when mounted in a test socket or printed circuit board with maintained transverse airflow greater than 500 lpm.

**3 Level Digital Logic**

S0, S1, and FSEL digital inputs are designed to sense 3 different logic levels designated as High “1”, Low “0” and Middle “M”. With this 3–Level digital input logic 9 different logic states can be detected.

S0, S1 and FSEL pins include an on chip 100 K (50 K / 50 K) resistor divider. No external application resistors are needed to implement the 3–Level logic levels as shown in table on the right:

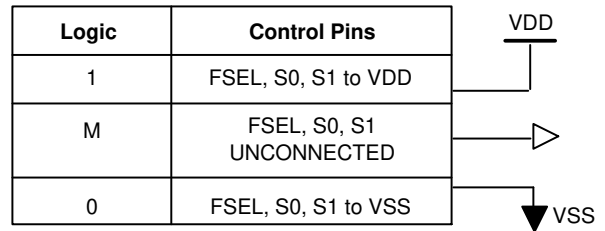

**Table 4. OPERATING CONDITIONS**

Symbol	Parameter	Min	Max	Unit
V <sub>DD</sub> , V <sub>IN</sub>	Voltage on any pin with respect to VSS	2.8	3.6	V
T <sub>A</sub>	Operating temperature	0	+70	°C
C <sub>L</sub>	Load Capacitance		15	pF
C <sub>IN</sub>	Input Capacitance		7	pF

**Table 5. ABSOLUTE MAXIMUM RATINGS**

Symbol	Parameter	Rating	Unit
V <sub>DD</sub> , V <sub>IN</sub>	Voltage on any pin with respect to Ground	-0.5 to +4.6	V
T <sub>STG</sub>	Storage temperature	-65 to +125	°C
T <sub>s</sub>	Max. Soldering Temperature (10 sec)	260	°C
T <sub>J</sub>	Junction Temperature	150	°C
T <sub>DV</sub>	Static Discharge Voltage (As per JEDEC STD 22– A114–B)	2	KV

Stresses exceeding those listed in the Maximum Ratings table may damage the device. If any of these limits are exceeded, device functionality should not be assumed, damage may occur and reliability may be affected.

# PCS3P25811, PCS3P25812, PCS3P25814

**Table 6. DC ELECTRICAL CHARACTERISTICS**

Symbol	Parameter		Min	Typ	Max	Units
V <sub>DD</sub>	Supply Voltage		2.8	3.3	3.6	V
V <sub>IL</sub>	Input low voltage (S0, S1, FSEL Inputs)	Commercial Temperature	0		0.15 V <sub>DD</sub>	V
		Industrial Temperature	0		0.13 V <sub>DD</sub>	
V <sub>IM</sub>	Input middle voltage (S0, S1, FSEL Inputs)		0.4 V <sub>DD</sub>		0.60 V <sub>DD</sub>	V
V <sub>IH</sub>	Input high voltage (S0, S1, FSEL Inputs)		0.85 V <sub>DD</sub>		V <sub>DD</sub>	V
V <sub>OL</sub>	Output low voltage (ModOUT Output)	I <sub>OL</sub> = 4 mA			0.4	V
		I <sub>OL</sub> = 10 mA			1.2	
V <sub>OH</sub>	Output high voltage (ModOUT Output)	I <sub>OH</sub> = -4 mA	2.4			V
		I <sub>OH</sub> = -6 mA	2			
C <sub>IN</sub>	Input Capacitance (XIN and XOUT)		6		9	pF
I <sub>DD</sub>	Dynamic supply current (Unloaded Output)	Commercial Temperature	XIN / CLKIN = 12 MHz		8	mA
			XIN / CLKIN = 24 MHz		10	
			XIN / CLKIN = 32 MHz		13	
		Industrial Temperature	XIN / CLKIN = 12 MHz		10	mA
			XIN / CLKIN = 24 MHz		12	
			XIN / CLKIN = 32 MHz		15	
I <sub>CC</sub>	Static supply current (XIN / CLKIN pulled to VSS)				0.5	mA

NOTE: Device will meet the specifications after thermal equilibrium has been established when mounted in a test socket or printed circuit board with maintained transverse airflow greater than 500 lpm.

**Table 7. AC ELECTRICAL CHARACTERISTICS**

Symbol	Parameter		Min	Typ	Max	Units
f <sub>IN</sub>	Input Clock frequency for PCS3P25811/12/14		4		32	MHz
f <sub>OUT</sub>	ModOUT Clock frequency for PCS3P25811		4		32	MHz
	ModOUT Clock frequency for PCS3P25812		8		64	
	ModOUT Clock frequency for PCS3P25814		16		128	
t <sub>LH</sub> (Notes 1, 2)	ModOUT Rise time (Measured from 20% to 80%)	PCS3P25811/12/14	2		5	nS
		PCS3P25814 when FSEL = M	1		2.2	
t <sub>HL</sub> (Notes 1, 2)	ModOUT Fall time (Measured from 80% to 20%)	PCS3P25811/12/14	2		4.4	nS
		PCS3P25814 when FSEL = M	1		2.2	
T <sub>DCIN</sub>	Input Clock Duty Cycle (XIN / CLKIN)		40		60	%
T <sub>DCOUT</sub> (Notes 1, 2)	Output Clock Duty Cycle (ModOUT)		40		60	%

1. Parameters are specified with 15 pF loaded outputs.
2. Parameter is guaranteed by design and characterization. Not 100% tested in production.

# PCS3P25811, PCS3P25812, PCS3P25814

**Table 7. AC ELECTRICAL CHARACTERISTICS**

Symbol	Parameter		Min	Typ	Max	Units
T <sub>JC</sub> (Note 2)	Cy–Cy Jitter, for ModOUT with Spread ON  (for Commercial temperature)	PCS3P25811	4 MHz		600	pS
			8 MHz		450	
		PCS3P25812	16 MHz		400	
			32 MHz		380	
		PCS3P25814	64 MHz		380	
			128 MHz		380	
t <sub>ON</sub> (Note 2)	PLL Lock Time (Stable power supply, valid input clock to valid Clock on ModOUT)	Commercial Temperature			2	mS
		Industrial Temperature			3	

- Parameters are specified with 15 pF loaded outputs.
- Parameter is guaranteed by design and characterization. Not 100% tested in production.

**Application Schematic**

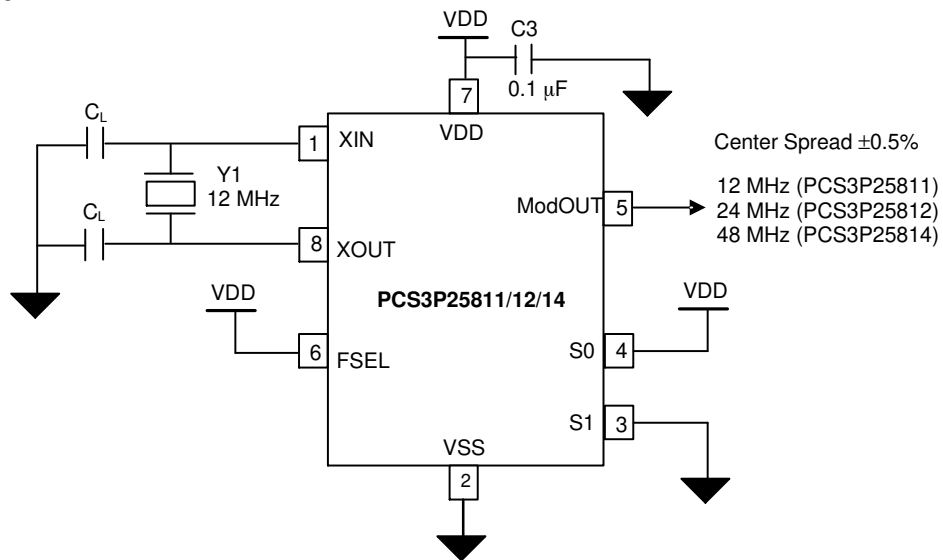
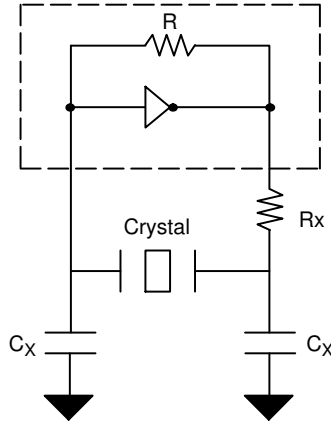

**Figure 2. Application Schematic**

**Table 8. TYPICAL CRYSTAL SPECIFICATIONS**

Fundamental AT Cut Parallel Resonant Crystal	
Nominal frequency	12 MHz
Frequency tolerance	±30 ppm or better at 25°C
Operating temperature range	–25°C to +85°C
Storage temperature	–40°C to +85°C
Load capacitance	18 pF
Shunt capacitance	7 pF maximum
ESR	25 Ω

NOTE: Device will meet the specifications after thermal equilibrium has been established when mounted in a test socket or printed circuit board with maintained transverse airflow greater than 500 lpm.



$C_X = 2 * (C_P - C_S)$ ,  
Where  $C_P$  = Load capacitance of crystal.  
 $C_S$  = Stray capacitance due to  $C_{IN}$ , PCB, Trace, etc.

**Figure 3. Typical Crystal Interface Circuit**

PACKAGE DIMENSIONS

SOIC-8 NB  
CASE 751-07  
ISSUE AK

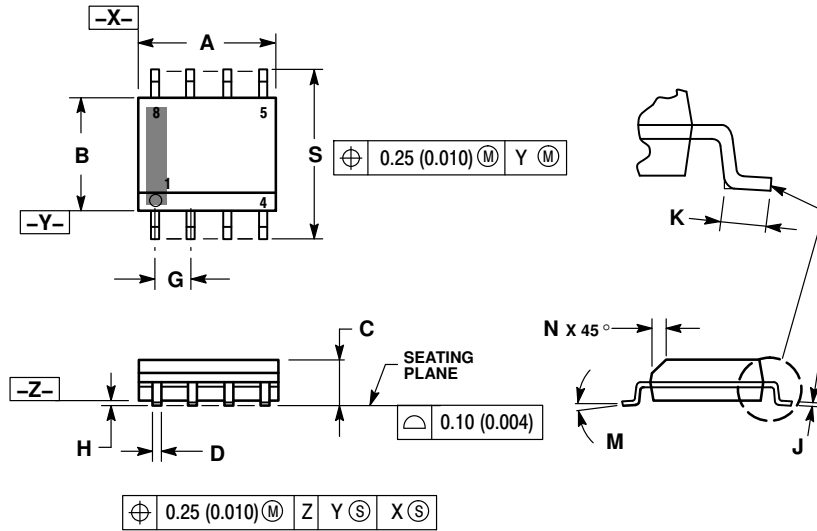

- NOTES:
1. DIMENSIONING AND TOLERANCING PER ANSI Y14.5M, 1982.
  2. CONTROLLING DIMENSION: MILLIMETER.
  3. DIMENSION A AND B DO NOT INCLUDE MOLD PROTRUSION.
  4. MAXIMUM MOLD PROTRUSION 0.15 (0.006) PER SIDE.
  5. DIMENSION D DOES NOT INCLUDE DAMBAR PROTRUSION. ALLOWABLE DAMBAR PROTRUSION SHALL BE 0.127 (0.005) TOTAL IN EXCESS OF THE D DIMENSION AT MAXIMUM MATERIAL CONDITION.
  6. 751-01 THRU 751-06 ARE OBSOLETE. NEW STANDARD IS 751-07.

DIM	MILLIMETERS		INCHES	
	MIN	MAX	MIN	MAX
A	4.80	5.00	0.189	0.197
B	3.80	4.00	0.150	0.157
C	1.35	1.75	0.053	0.069
D	0.33	0.51	0.013	0.020
G	1.27 BSC		0.050 BSC	
H	0.10	0.25	0.004	0.010
J	0.19	0.25	0.007	0.010
K	0.40	1.27	0.016	0.050
M	0°	8°	0°	8°
N	0.25	0.50	0.010	0.020
S	5.80	6.20	0.228	0.244

SOLDERING FOOTPRINT\*

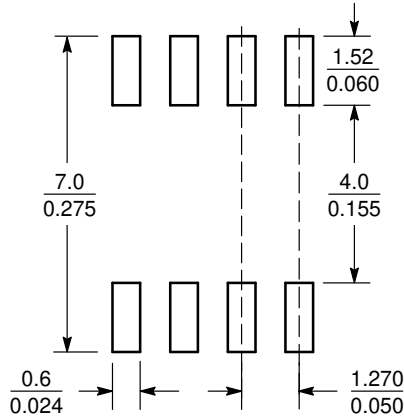

SCALE 6:1 (mm/inches)

\*For additional information on our Pb-Free strategy and soldering details, please download the ON Semiconductor Soldering and Mounting Techniques Reference Manual, SOLDERRM/D.



# PCS3P25811, PCS3P25812, PCS3P25814

## PACKAGE DIMENSIONS

WDFN8 2x2, 0.5P  
CASE 511AQ  
ISSUE A

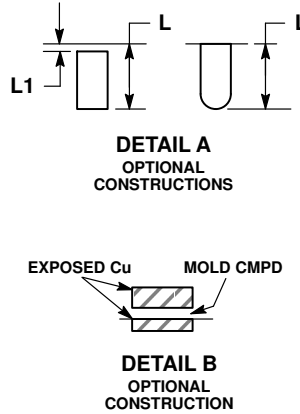
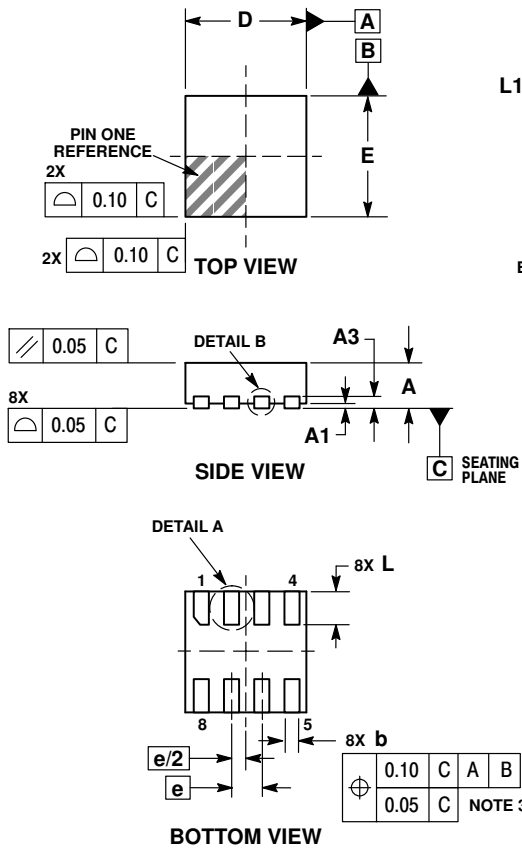

- NOTES:
1. DIMENSIONING AND TOLERANCING PER ASME Y14.5M, 1994.
  2. CONTROLLING DIMENSION: MILLIMETERS.
  3. DIMENSION b APPLIES TO PLATED TERMINAL AND IS MEASURED BETWEEN 0.15 AND 0.30mm FROM TERMINAL.

DIM	MILLIMETERS	
	MIN	MAX
A	0.70	0.80
A1	0.00	0.05
A3	0.20 REF	
b	0.20	0.30
D	2.00 BSC	
E	2.00 BSC	
e	0.50 BSC	
L	0.50	0.60
L1	---	0.15

### RECOMMENDED SOLDERING FOOTPRINT\*

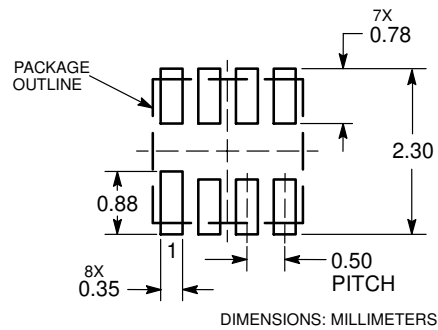

\*For additional information on our Pb-Free strategy and soldering details, please download the ON Semiconductor Soldering and Mounting Techniques Reference Manual, SOLDERRM/D.

# PCS3P25811, PCS3P25812, PCS3P25814

**Table 9. ORDERING INFORMATION**

Part Number	Marking	Package Type	Temperature
PCS3P25811AG08SR	CGL	8-pin SOIC – Tape & Reel, Green	0°C to +70°C
P3P25812AG-08SR	CIL	8-pin SOIC – Tape & Reel, Green	0°C to +70°C
P3P25814AG-08SR	CKL	8-pin SOIC – Tape & Reel, Green	0°C to +70°C
P3P25811AG-08CR	CG	8L-WDFN (2 mm x 2 mm) – Tape & Reel, Green	0°C to +70°C
P3P25812AG-08CR	CI	8L-WDFN (2 mm x 2 mm) – Tape & Reel, Green	0°C to +70°C
P3P25814AG-08CR	CK	8L-WDFN (2 mm x 2 mm) – Tape & Reel, Green	0°C to +70°C

NOTE: Device will meet the specifications after thermal equilibrium has been established when mounted in a test socket or printed circuit board with maintained transverse airflow greater than 500 lpm.

**ON Semiconductor** and  are registered trademarks of Semiconductor Components Industries, LLC (SCILLC). SCILLC owns the rights to a number of patents, trademarks, copyrights, trade secrets, and other intellectual property. A listing of SCILLC's product/patent coverage may be accessed at [www.onsemi.com/site/pdf/Patent-Marking.pdf](http://www.onsemi.com/site/pdf/Patent-Marking.pdf). SCILLC reserves the right to make changes without further notice to any products herein. SCILLC makes no warranty, representation or guarantee regarding the suitability of its products for any particular purpose, nor does SCILLC assume any liability arising out of the application or use of any product or circuit, and specifically disclaims any and all liability, including without limitation special, consequential or incidental damages. "Typical" parameters which may be provided in SCILLC data sheets and/or specifications can and do vary in different applications and actual performance may vary over time. All operating parameters, including "Typicals" must be validated for each customer application by customer's technical experts. SCILLC does not convey any license under its patent rights nor the rights of others. SCILLC products are not designed, intended, or authorized for use as components in systems intended for surgical implant into the body, or other applications intended to support or sustain life, or for any other application in which the failure of the SCILLC product could create a situation where personal injury or death may occur. Should Buyer purchase or use SCILLC products for any such unintended or unauthorized application, Buyer shall indemnify and hold SCILLC and its officers, employees, subsidiaries, affiliates, and distributors harmless against all claims, costs, damages, and expenses, and reasonable attorney fees arising out of, directly or indirectly, any claim of personal injury or death associated with such unintended or unauthorized use, even if such claim alleges that SCILLC was negligent regarding the design or manufacture of the part. SCILLC is an Equal Opportunity/Affirmative Action Employer. This literature is subject to all applicable copyright laws and is not for resale in any manner.

## PUBLICATION ORDERING INFORMATION

### LITERATURE FULFILLMENT:

Literature Distribution Center for ON Semiconductor  
P.O. Box 5163, Denver, Colorado 80217 USA  
**Phone:** 303-675-2175 or 800-344-3860 Toll Free USA/Canada  
**Fax:** 303-675-2176 or 800-344-3867 Toll Free USA/Canada  
**Email:** [orderlit@onsemi.com](mailto:orderlit@onsemi.com)

**N. American Technical Support:** 800-282-9855 Toll Free  
USA/Canada  
**Europe, Middle East and Africa Technical Support:**  
Phone: 421 33 790 2910  
**Japan Customer Focus Center**  
Phone: 81-3-5817-1050

**ON Semiconductor Website:** [www.onsemi.com](http://www.onsemi.com)  
**Order Literature:** <http://www.onsemi.com/orderlit>  
For additional information, please contact your local Sales Representative