



Chipsmall Limited consists of a professional team with an average of over 10 year of expertise in the distribution of electronic components. Based in Hongkong, we have already established firm and mutual-benefit business relationships with customers from,Europe,America and south Asia,supplying obsolete and hard-to-find components to meet their specific needs.

With the principle of “Quality Parts,Customers Priority,Honest Operation,and Considerate Service”,our business mainly focus on the distribution of electronic components. Line cards we deal with include Microchip,ALPS,ROHM,Xilinx,Pulse,ON,Everlight and Freescale. Main products comprise IC,Modules,Potentiometer,IC Socket,Relay,Connector.Our parts cover such applications as commercial,industrial, and automotives areas.

We are looking forward to setting up business relationship with you and hope to provide you with the best service and solution. Let us make a better world for our industry!



Contact us

Tel: +86-755-8981 8866 Fax: +86-755-8427 6832

Email & Skype: info@chipsmall.com Web: www.chipsmall.com

Address: A1208, Overseas Decoration Building, #122 Zhenhua RD., Futian, Shenzhen, China



P3P8163A

3.3V, LVCMOS Spread Spectrum Peak EMI Reduction Device

Product Description

P3P8163A is a 3.3 V, spread spectrum frequency modulator that generates a 1x, LVCMOS low EMI spread spectrum clock and two reference clock outputs.

The P3P8163A reduces electromagnetic interference (EMI) at the clock source, allowing system wide reduction of EMI of down stream clock and data dependent signals. It allows significant system cost savings by reducing the number of circuit board layers, ferrite beads, shielding, and other passive components that are traditionally required to pass EMI regulations.

The P3P8163A can generate an EMI reduced clock from a fundamental Crystal or from an external reference clock.

P3P8163A has a SEL pin to turn off CLK2 when '1'.

Refer Output Table.

P3P8163A operates over 3.3 V $\pm 5\%$ supply voltage range and is available in 8 pin SOIC package.

Features

- Input Clock: 12 MHz from Fundamental XTAL or External Reference Clock
- Output Clocks:
 - CLK0: 12 MHz $\pm 0.4\%$
 - CLK1, CLK2: 12 MHz (REFOUT)
- SEL Pin to Turn Off CLK2
- Low Inherent Cycle-to-Cycle Jitter
- Supply Voltage: 3.3 V $\pm 5\%$
- LVCMOS Input and Output
- Operating Temperature Range: 0°C to 70°C
- 8-pin SOIC Package
- These Devices are Pb-Free, Halogen Free/BFR Free and are RoHS Compliant

Application

- The P3P8163A is targeted towards EMI management in consumer electronics applications including MFPs.

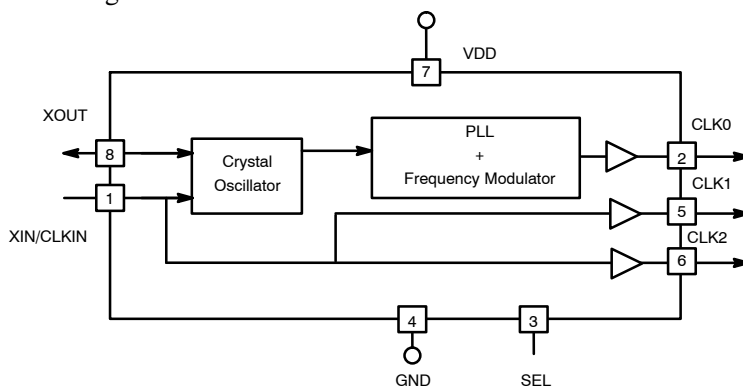

Figure 1. Simplified Block Diagram



ON Semiconductor®

<http://onsemi.com>

MARKING DIAGRAM

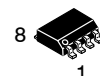

SOIC-8
D SUFFIX
CASE 751

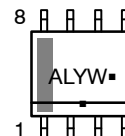

xx = Specific Device Code
A = Assembly Location
L = Wafer Lot
Y = Year
W = Work Week
▪ = Pb-Free Package

ORDERING INFORMATION

See detailed ordering and shipping information in the package dimensions section on page 5 of this data sheet.

P3P8163A

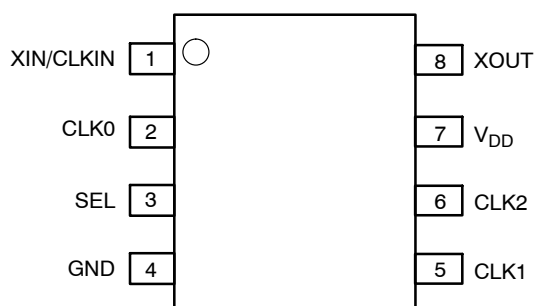

Figure 2. Pin Configuration

Table 1. PIN DESCRIPTION

Pin #	Pin Name	Type	Description
1	XIN / CLKIN	Input	Crystal connection or External Clock input.
2	CLK0	Output	Spread Spectrum Clock output.
3	SEL	Input	2 level logic input. When '0' CLK2 is enabled. When '1' CLK2 is turned off. Has a Pull-down resistor.
4	GND	Power	Ground to entire chip.
5	CLK1	Output	Reference clock Output.
6	CLK2	Output	Reference clock Output. Has a Pull-down resistor when OFF.
7	V _{DD}	Power	Power supply for the entire chip
8	XOUT	Output	Crystal connection. If using an external reference, this pin must be left unconnected.

Table 2. OUTPUT TABLE

SEL	CLK0	CLK1	CLK2
0	Spread Spectrum Clock output	Reference clock Output	Reference clock Output
1	Spread Spectrum Clock output	Reference clock Output	OFF

Table 3. OPERATING CONDITIONS

Symbol	Description	Min	Max	Unit
V _{DD}	Voltage on any pin with respect to GND	3.135	3.465	V
T _A	Operating temperature	0	+70	°C
C _L	Load Capacitance		15	pF
C _{IN}	Input Capacitance		7	pF

P3P8163A

Table 4. MAXIMUM RATINGS

Symbol	Parameter	Rating	Unit
V_{DD}, V_{IN}	Voltage on any pin with respect to Ground	-0.5 to +4.6	V
T_{STG}	Storage temperature	-65 to +125	°C
T_s	Max. Soldering Temperature (10 sec)	260	°C
T_J	Junction Temperature	150	°C
T_{DV}	Static Discharge Voltage(As per JEDEC STD 22- A114-B)	2	kV

Stresses exceeding Maximum Ratings may damage the device. Maximum Ratings are stress ratings only. Functional operation above the Recommended Operating Conditions is not implied. Extended exposure to stresses above the Recommended Operating Conditions may affect device reliability.

NOTE: These are stress ratings only and are not implied for functional use. Exposure to absolute maximum ratings for prolonged periods of time may affect device reliability.

Table 5. DC ELECTRICAL CHARACTERISTICS

(NOTE – Unless otherwise stated $V_{DD} = 3.3\text{ V} \pm 5\%$, $C_L = 15\text{ pF}$ and Ambient Temperature range 0°C to $+70^\circ\text{C}$)

Symbol	Parameter	Min	Typ	Max	Unit
V_{DD}	Supply Voltage	3.135	3.3	3.465	V
I_{DD}	Dynamic supply current ($C_L = 15\text{ pF}$, $V_{DD} = 3.465\text{ V}$, Temp = $+70^\circ\text{C}$)			17	mA
V_{IL}	Input low voltage (XIN/CLKIN, SEL Inputs)	0		0.8	V
V_{IH}	Input high voltage (XIN/CLKIN, SEL Inputs)	$0.9 * V_{DD}$		V_{DD}	V
V_{OL}	Output low voltage (CLK[0:2])	$I_{OL} = 12\text{ mA}$		0.4	V
V_{OH}	Output high voltage (CLK[0:2])	$I_{OH} = -12\text{ mA}$	2.4		V
C_{IN1}	Input Capacitance (XIN/CLKIN and XOUT)		6		pF
C_{IN2}	Input capacitance (SEL Input)			7	pF
R_{PD}	Internal Pull down Resistor (CLK2)		200		k Ω
Z_0	Output Impedance		25		Ω

NOTE: The voltage on any input or I/O pin cannot exceed the power pin during power up.

P3P8163A

Table 6. AC ELECTRICAL CHARACTERISTICS

(NOTE – Unless otherwise stated $V_{DD} = 3.3\text{ V} \pm 5\%$, $C_L = 15\text{ pF}$ and Ambient Temperature range 0°C to $+70^\circ\text{C}$)

Symbol	Parameter	Min	Typ	Max	Unit
f_{IN}	Input Clock frequency		12		MHz
f_{OUT}	CLK0, Modulated output Clock, $\pm 0.4\%$		12		MHz
	CLK1, CLK2 Reference clock output		12		
t_{LH}, t_{HL} (Notes 1 and 2)	CLK0, Rise and Fall time (Measured between 20% to 80%)		1.25	2.0	ns
t_{LH}, t_{HL} (Notes 1 and 2)	CLK1, CLK2, Rise and Fall time (Measured between 20% to 80%)		1.25	2.0	ns
TDCOUT (Notes 1 and 2)	Output Clock Duty Cycle	45	50	55	%
T_{JC} (Note 2)	Cycle–Cycle Jitter, Peak (1000 cycles) (For CLK0)		150		pS
T_{JP} (Note 2)	Period Jitter, Peak (10000 cycles) (For CLK1, CLK2)		125		pS
t_{ON} (Notes 1 and 2)	Power Up Time (Stable power supply, valid input clock to valid clock on CLK0).			4	ms
f_{dvar}	Frequency Deviation (CLK0)		± 0.4	± 0.52	%

- Parameters are specified with 15 pF loaded outputs.
- Parameter is guaranteed by design and characterization. Not 100% tested in production

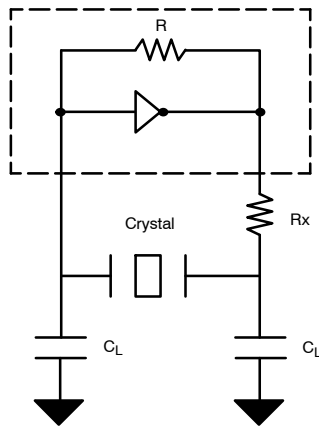

$$C_L = 2 * (C_P - C_S)$$

Where C_P = Load capacitance of crystal specified in a Crystal Datasheet
 C_S = Stray capacitance due to CIN, PCB, Trace etc
 C_L = Load capacitance to be used
 R_x is used to reduce power dissipation in the Crystal

Figure 3. Typical Crystal Interface Circuit

P3P8163A

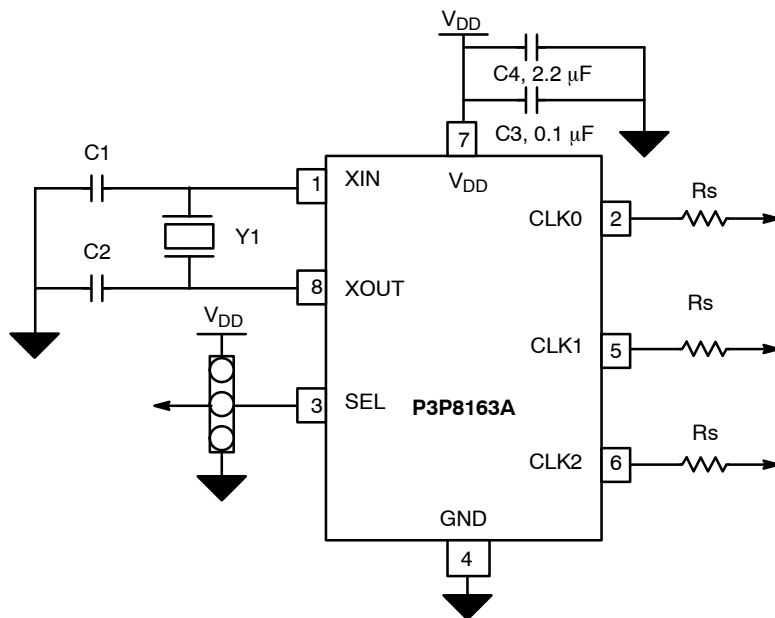

Rs = Trace Impedance of PCB – Output Impedance of Device (Z0)

Figure 4. Typical Application Schematic

ORDERING INFORMATION

Device	Top Marking	Temperature	Package	Shipping [†]
P3P8163AG-08SR	CUL	0°C to +70°C	SOIC-8 (Pb-Free)	2500 / Tape & Reel

[†]For information on tape and reel specifications, including part orientation and tape sizes, please refer to our Tape and Reel Packaging Specifications Brochure, BRD8011/D.

P3P8163A

PACKAGE DIMENSIONS

SOIC-8 NB
CASE 751-07
ISSUE AK

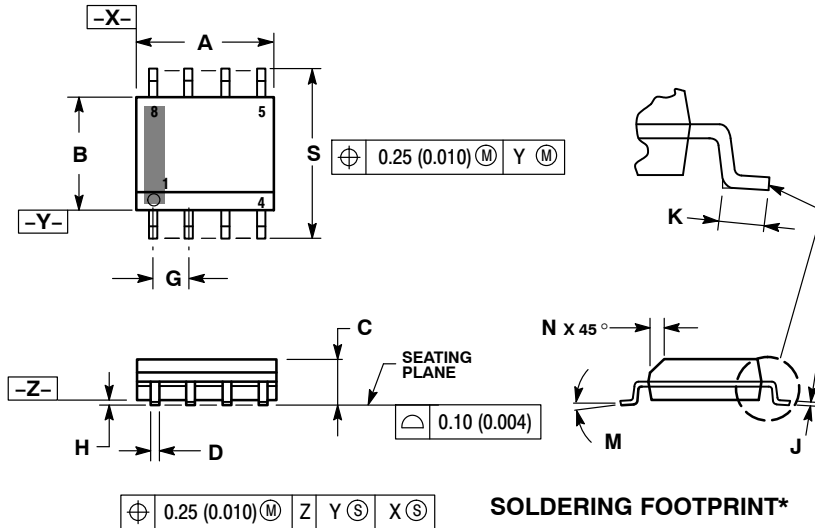

NOTES:

1. DIMENSIONING AND TOLERANCING PER ANSI Y14.5M, 1982.
2. CONTROLLING DIMENSION: MILLIMETER.
3. DIMENSION A AND B DO NOT INCLUDE MOLD PROTRUSION.
4. MAXIMUM MOLD PROTRUSION 0.15 (0.006) PER SIDE.
5. DIMENSION D DOES NOT INCLUDE DAMBAR PROTRUSION. ALLOWABLE DAMBAR PROTRUSION SHALL BE 0.127 (0.005) TOTAL IN EXCESS OF THE D DIMENSION AT MAXIMUM MATERIAL CONDITION.
6. 751-01 THRU 751-06 ARE OBSOLETE. NEW STANDARD IS 751-07.

DIM	MILLIMETERS		INCHES	
	MIN	MAX	MIN	MAX
A	4.80	5.00	0.189	0.197
B	3.80	4.00	0.150	0.157
C	1.35	1.75	0.053	0.069
D	0.33	0.51	0.013	0.020
G	1.27 BSC		0.050 BSC	
H	0.10	0.25	0.004	0.010
J	0.19	0.25	0.007	0.010
K	0.40	1.27	0.016	0.050
M	0°	8°	0°	8°
N	0.25	0.50	0.010	0.020
S	5.80	6.20	0.228	0.244

SOLDERING FOOTPRINT*

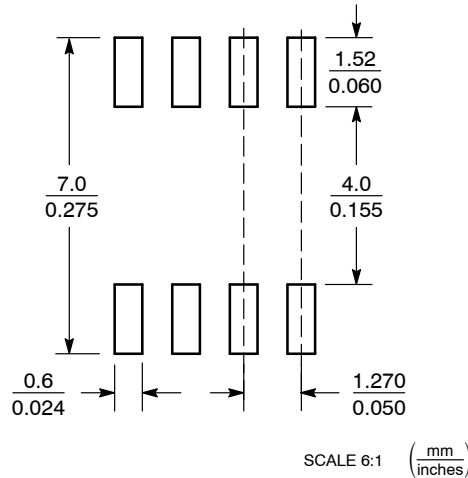

*For additional information on our Pb-Free strategy and soldering details, please download the ON Semiconductor Soldering and Mounting Techniques Reference Manual, SOLDERRM/D.

ON Semiconductor and are registered trademarks of Semiconductor Components Industries, LLC (SCILLC). SCILLC reserves the right to make changes without further notice to any products herein. SCILLC makes no warranty, representation or guarantee regarding the suitability of its products for any particular purpose, nor does SCILLC assume any liability arising out of the application or use of any product or circuit, and specifically disclaims any and all liability, including without limitation special, consequential or incidental damages. "Typical" parameters which may be provided in SCILLC data sheets and/or specifications can and do vary in different applications and actual performance may vary over time. All operating parameters, including "Typicals" must be validated for each customer application by customer's technical experts. SCILLC does not convey any license under its patent rights nor the rights of others. SCILLC products are not designed, intended, or authorized for use as components in systems intended for surgical implant into the body, or other applications intended to support or sustain life, or for any other application in which the failure of the SCILLC product could create a situation where personal injury or death may occur. Should Buyer purchase or use SCILLC products for any such unintended or unauthorized application, Buyer shall indemnify and hold SCILLC and its officers, employees, subsidiaries, affiliates, and distributors harmless against all claims, costs, damages, and expenses, and reasonable attorney fees arising out of, directly or indirectly, any claim of personal injury or death associated with such unintended or unauthorized use, even if such claim alleges that SCILLC was negligent regarding the design or manufacture of the part. SCILLC is an Equal Opportunity/Affirmative Action Employer. This literature is subject to all applicable copyright laws and is not for resale in any manner.

PUBLICATION ORDERING INFORMATION

LITERATURE FULFILLMENT:
Literature Distribution Center for ON Semiconductor
P.O. Box 5163, Denver, Colorado 80217 USA
Phone: 303-675-2175 or 800-344-3860 Toll Free USA/Canada
Fax: 303-675-2176 or 800-344-3867 Toll Free USA/Canada
Email: orderlit@onsemi.com

N. American Technical Support: 800-282-9855 Toll Free USA/Canada
Europe, Middle East and Africa Technical Support:
Phone: 421 33 790 2910
Japan Customer Focus Center
Phone: 81-3-5773-3850

ON Semiconductor Website: www.onsemi.com
Order Literature: <http://www.onsemi.com/orderlit>
For additional information, please contact your local Sales Representative