



Chipsmall Limited consists of a professional team with an average of over 10 year of expertise in the distribution of electronic components. Based in Hongkong, we have already established firm and mutual-benefit business relationships with customers from,Europe,America and south Asia,supplying obsolete and hard-to-find components to meet their specific needs.

With the principle of “Quality Parts,Customers Priority,Honest Operation,and Considerate Service”,our business mainly focus on the distribution of electronic components. Line cards we deal with include Microchip,ALPS,ROHM,Xilinx,Pulse,ON,Everlight and Freescale. Main products comprise IC,Modules,Potentiometer,IC Socket,Relay,Connector.Our parts cover such applications as commercial,industrial, and automotives areas.

We are looking forward to setting up business relationship with you and hope to provide you with the best service and solution. Let us make a better world for our industry!



## Contact us

Tel: +86-755-8981 8866 Fax: +86-755-8427 6832

Email & Skype: info@chipsmall.com Web: www.chipsmall.com

Address: A1208, Overseas Decoration Building, #122 Zhenhua RD., Futian, Shenzhen, China



RPC-N  
75 Ω

Short Circuit  
Jack

**P5K12S-00AS3**

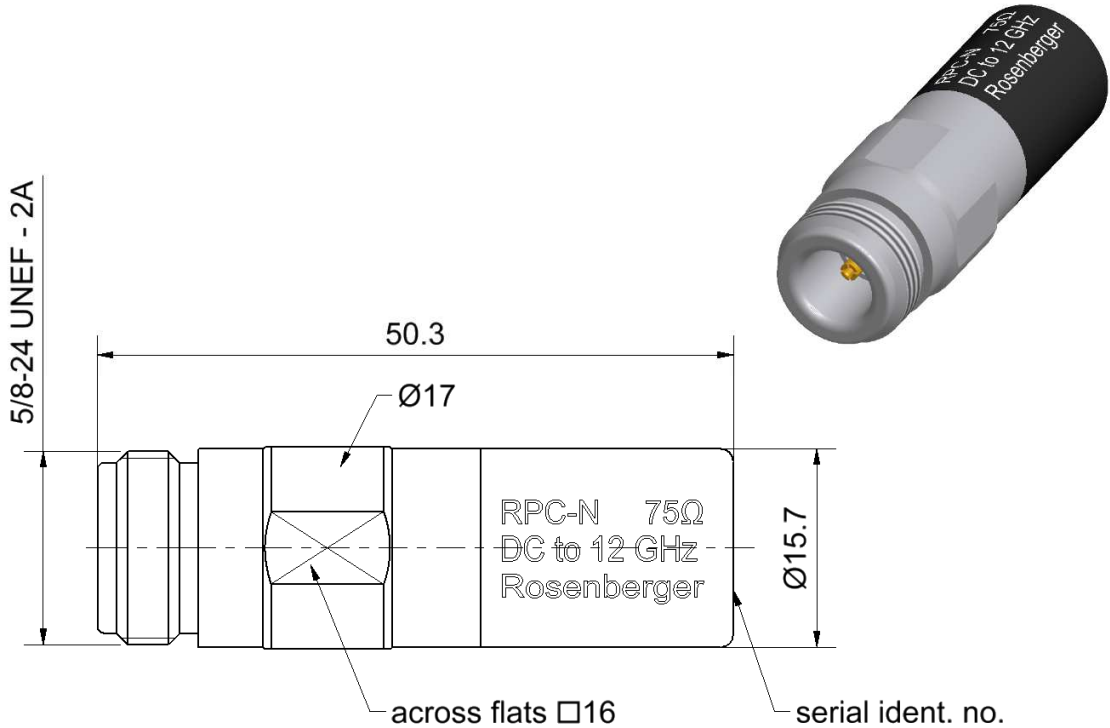

All dimensions are in mm; tolerances according to ISO 2768 m-H

**Interface**

According to IEC 61169-16

**Documents**

Application note AN001 "Calibration Services"

**Material and plating**

**Connector parts**

Center conductor  
Outer conductor

**Material**

CuBe  
Stainless steel

**Plating**

Gold, min. 1.27 μm, over nickel  
Passivated

Dieses Dokument ist urheberrechtlich geschützt • This document is protected by copyright • Rosenberger Hochfrequenztechnik GmbH & Co. KG

RF\_35/09;14/6.2

**Electrical data**

Frequency range	DC to 12 GHz
Return loss	≤ 0.10 dB, DC to 4 GHz ≤ 0.15 dB, 4 GHz to 8 GHz ≤ 0.20 dB, 8 GHz to 12 GHz
Error from nominal phase <sup>1</sup>	≤ 1.5°, DC to 4 GHz ≤ 3.0°, 4 GHz to 8 GHz ≤ 4.0°, 8 GHz to 12 GHz

<sup>1</sup> The nominal phase is defined by the Offset Delay, the Offset Loss and the Short Inductance.

**Mechanical data**

Mating cycles	≥ 500
Maximum torque	1.70 Nm
Recommended torque	1.10 Nm
Gauge	5.18 mm to 5.26 mm

**General standard definitions**

For proper operation the vector network analyzer (VNA) needs a model describing the electrical behaviour of this calibration standard. The different models, units, and terms used will depend on the VNA type and they will have to be entered into the VNA. All values are based on typical geometry and plating.

Offset $Z_o$ / Impedance / $Z_o$	75 Ω
Offset Delay	41.095 ps
Length (electrical) / Offset Length	12.32 mm
Offset Loss	1.20 GΩ/s
Loss	0.0057 dB/√GHz
Short Inductance <sup>2</sup>	

<sup>2</sup> Short Inductances are determined individually for each Short circuit and are documented in a Calibration Certificate.

**Environmental data**

Operating temperature range <sup>3</sup>	+20 °C to +26 °C
Rated temperature range of use <sup>4</sup>	0 °C to +50 °C
Storage temperature range	- 40 °C to +85 °C

RoHS compliant

<sup>3</sup> Temperature range over which these specification are valid.

<sup>4</sup> This range is underneath and above the operating temperature range, within the calibration adaptor is fully functional and could be used without damage.

RPC-N  
75 Ω

Short Circuit  
Jack

**P5K12S-00AS3**

**Declaration of calibration options**

**Factory Calibration**

Standard delivery for this calibration standard includes a Factory Calibration. The Calibration Certificate issued reports individual calibration results, traceable to national / international standards. Model based standard definitions are individually optimized and reported in an Agilent/Keysight, Rohde & Schwarz and Anritsu compatible VNA format.

**Accredited Calibration**

Optional this calibration standard can be delivered with an Accredited Calibration (DAkkS) having the highest confidence in the traceability. The DAkkS Calibration Certificate issued reports individual calibration results in a complex format, traceable to national / international standards. Model based standard definitions are individually optimized and reported in an Agilent/Keysight, Rohde & Schwarz and Anritsu compatible VNA format as well as in a dense data set needed for data based standard definitions. The uncertainties are smaller than in a Factory Calibration.

*For further, more detailed information see application note AN001 on the Rosenberger homepage.*

**Calibration interval**

Recommendation 12 months

**Packing**

Standard 1 pce in box  
Weight 44.3 g/pce

While the information has been carefully compiled to the best of our knowledge, nothing is intended as representation or warranty on our part and no statement herein shall be construed as recommendation to infringe existing patents. In the effort to improve our products, we reserve the right to make changes judged to be necessary.

Draft	Date	Approved	Date	Rev.	Engineering change number	Name	Date
Marion Striegler	27.02.14	Markus Müller	10.08.16	f00	16-1267	Marion Striegler	10.08.16
Rosenberger Hochfrequenztechnik GmbH & Co. KG P.O.Box 1260 D-84526 Tittmoning Germany www.rosenberger.de					Tel. : +49 8684 18-0 Email : info@rosenberger.de		Page 3 / 3