



Chipsmall Limited consists of a professional team with an average of over 10 year of expertise in the distribution of electronic components. Based in Hongkong, we have already established firm and mutual-benefit business relationships with customers from,Europe,America and south Asia,supplying obsolete and hard-to-find components to meet their specific needs.

With the principle of “Quality Parts,Customers Priority,Honest Operation,and Considerate Service”,our business mainly focus on the distribution of electronic components. Line cards we deal with include Microchip,ALPS,ROHM,Xilinx,Pulse,ON,Everlight and Freescale. Main products comprise IC,Modules,Potentiometer,IC Socket,Relay,Connector.Our parts cover such applications as commercial,industrial, and automotives areas.

We are looking forward to setting up business relationship with you and hope to provide you with the best service and solution. Let us make a better world for our industry!



## Contact us

Tel: +86-755-8981 8866 Fax: +86-755-8427 6832

Email & Skype: info@chipsmall.com Web: www.chipsmall.com

Address: A1208, Overseas Decoration Building, #122 Zhenhua RD., Futian, Shenzhen, China



# Power over Ethernet protection

PEP01-5841

## A new Transil™ array to protect power supplies



Power over Ethernet eliminates the need for external power supplies on the customer's side as they are included in routers and are able to deliver up to 30 W under 48 V (POE+) according to IEEE 802.3af. Power is transported using two pairs in an Ethernet cable. As for all cables, they are subject to surges and must be protected against electrostatic discharge (ESD) and electrical overstress (EOS).

### Key features

- PEP01-5841  
The PEP01-5841 embeds 4 protection units that are fine tuned in voltage and current for POE applications, and 4 capacitances to filter high-frequency disturbances.
- Temperature capability  
The PEP01-5841 is specified with  $I_{Rmax} = 1 \mu A$  at 85 °C (telecommunication temperature) and 0.2  $\mu A$  at 25 °C.  $T_{Jmax}$  is compliant with the industrial standard for tough environments: 150 °C
- Surge capability  
To be compliant with IEC 61000-4-5 level 2 (1 kV), the PEP01-5841 is specified at 24 A 8/20  $\mu s$  and the  $V_{CL}$  has been improved to be compatible with 100 V PMOS and PSE controller technologies.  $V_{BRmin}$  has been defined to take into account tolerance on power supply voltage and can be calculated whatever the temperature is using ( $\alpha T$ ):

$$V_{BRmin @ T_J} = V_{BRmin @ 25^\circ C} \times (1 + \alpha T \times (T_J - 25))$$

Dynamic resistance ( $R_D$ ) is given to calculate  $V_{CLmax}$  at other current surge values, for instance at 12 A (IEC 61000-4-5 level 1,500 V):

$$V_{CLmax} = R_D \times I_{PP} + V_{BRmax}$$

$$V_{CLmax} = 85.6 \text{ V}$$

The PEP01-5841 is able to protect against ESD up to 30 kV according to IEC 61000-4-2.

### Key benefits

- Compliant with IEC 61000-4-5 level 2 (1 kV – 24 A 8/20  $\mu s$ )
- Compatible with PMOS and PSE controller voltages (maximum clamping voltage: 100 V)
- Low leakage current in telecommunication temperature range
- 4 protection units/filtering in 1 S0-8 package (55% space saving)

### Target applications

- Power over Ethernet (POE and POE+)

### Package

The PEP01-5841 is packaged in an SO8 (28 mm<sup>2</sup>) which provides 55% space saving versus 4 x SMA (Transils) + 4 x 0306 capacitances.

### Relevant standards

As an Ethernet cable is a dataline, the impedance of the IEC 61000-4-5 surge generator is  $42 \Omega$ . Surge level is either 500 V or 1 kV, leading to surge currents of 12 A or 24 A respectively (8/20  $\mu$ s).

The second standard is IEC 61000-4-2, which defines ESD surges.

### State-of-the-art protection

Protection is achieved using the SMAJ58A and SMBJ58A Transils specified with  $V_{CLmax} = 121$  V, which is higher than the maximum admissible voltage of PMOS and PSE controllers.

### Application schematic

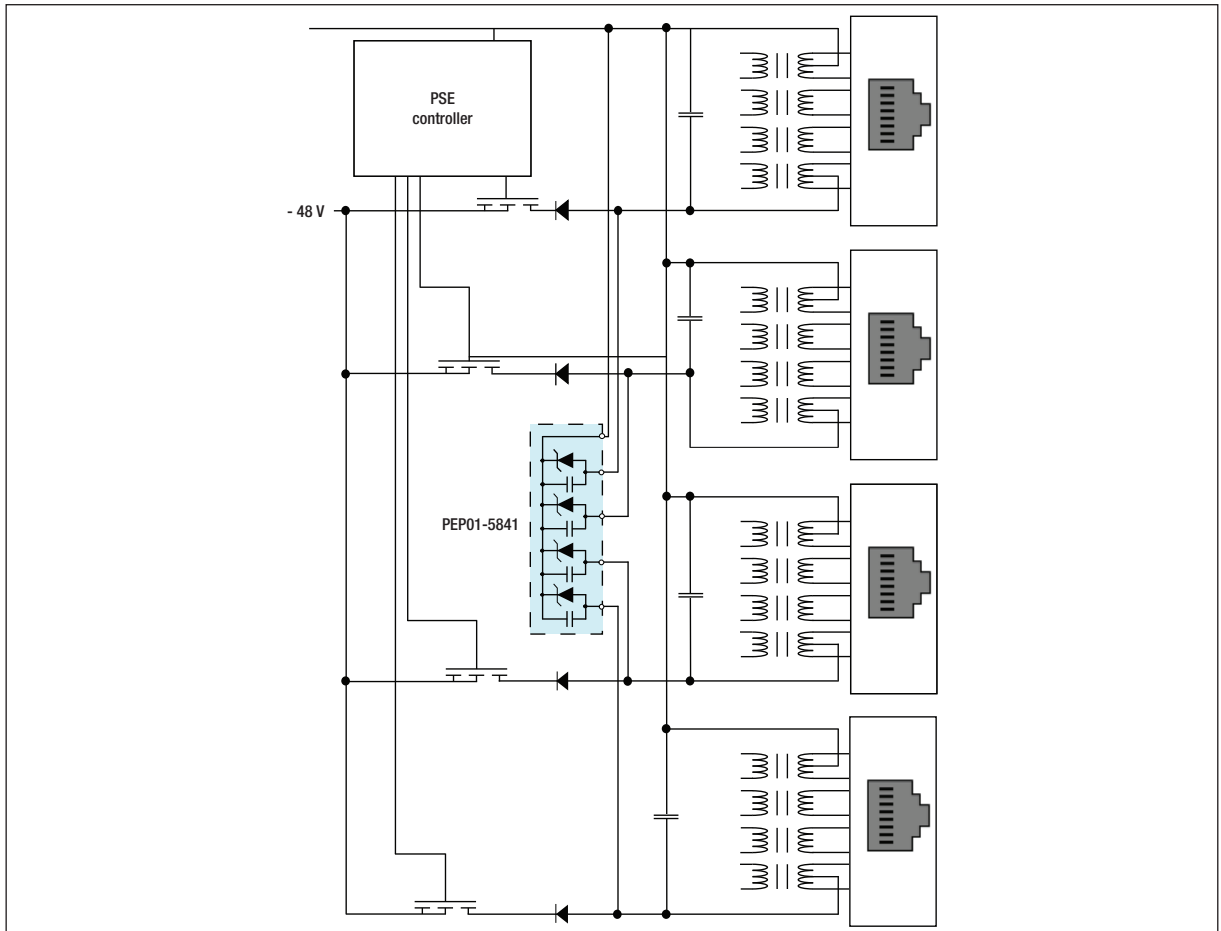

© STMicroelectronics - April 2009 - Printed in Italy - All rights reserved

The STMicroelectronics corporate logo is a registered trademark of the STMicroelectronics group of companies.  
Transil, Trisil and Transky are trademarks of STMicroelectronics. All other names are the property of their respective owners.

For more information on ST products and solutions,  
visit [www.st.com](http://www.st.com)