



Chipsmall Limited consists of a professional team with an average of over 10 year of expertise in the distribution of electronic components. Based in Hongkong, we have already established firm and mutual-benefit business relationships with customers from,Europe,America and south Asia,supplying obsolete and hard-to-find components to meet their specific needs.

With the principle of “Quality Parts,Customers Priority,Honest Operation,and Considerate Service”,our business mainly focus on the distribution of electronic components. Line cards we deal with include Microchip,ALPS,ROHM,Xilinx,Pulse,ON,Everlight and Freescale. Main products comprise IC,Modules,Potentiometer,IC Socket,Relay,Connector.Our parts cover such applications as commercial,industrial, and automotives areas.

We are looking forward to setting up business relationship with you and hope to provide you with the best service and solution. Let us make a better world for our industry!



Contact us

Tel: +86-755-8981 8866 Fax: +86-755-8427 6832

Email & Skype: info@chipsmall.com Web: www.chipsmall.com

Address: A1208, Overseas Decoration Building, #122 Zhenhua RD., Futian, Shenzhen, China



DATA SHEET

P87C51RA2/RB2/RC2/RD2

80C51 8-bit microcontroller family

8KB/16KB/32KB/64KB OTP, 512B/512B/512B/1KB RAM,
low voltage (2.7 to 5.5 V), low power, high speed
(30/33 MHz)

Product data

Supersedes data of 2002 Oct 28

2003 Jan 24

**80C51 8-bit microcontroller family 8KB/16KB/32KB/64KB OTP
with 512B/1KB RAM, low voltage (2.7 to 5.5 V), low power, high
speed (30/33 MHz)**

P87C51RA2/RB2/RC2/RD2

DESCRIPTION

The devices are Single-Chip 8-Bit Microcontrollers manufactured in an advanced CMOS process and are derivatives of the 80C51 microcontroller family. The instruction set is 100% compatible with the 80C51 instruction set.

The devices support 6-clock/12-clock mode selection by programming an OTP bit (OX2) using parallel programming. In addition, an SFR bit (X2) in the clock control register (CKCON) also selects between 6-clock/12-clock mode.

The devices also have four 8-bit I/O ports, three 16-bit timer/event counters, a multi-source, four-priority-level, nested interrupt structure, an enhanced UART and on-chip oscillator and timing circuits.

The added features of the P87C51RA2/RB2/RC2/RD2 make it a powerful microcontroller for applications that require pulse width modulation, high-speed I/O and up/down counting capabilities such as motor control.

FEATURES

- 80C51 Central Processing Unit
 - 8 kbytes OTP (87C51RA2)
 - 16 kbytes OTP (87C51RB2)
 - 32 kbytes OTP (87C51RC2)
 - 64 kbytes OTP (87C51RD2)
 - 512 byte RAM (87C51RA2/RB2/RC2)
 - 1 kbyte RAM (87C51RD2)
 - Boolean processor
 - Fully static operation
 - Low voltage (2.7 V to 5.5 V at 16 MHz) operation
- 12-clock operation with selectable 6-clock operation (via software or via parallel programmer)
- Memory addressing capability
 - Up to 64 kbytes ROM and 64 kbytes RAM
- Power control modes:
 - Clock can be stopped and resumed
 - Idle mode
 - Power-down mode
- CMOS and TTL compatible
- Two speed ranges at $V_{CC} = 5\text{ V}$
 - 0 to 30 MHz with 6-clock operation
 - 0 to 33 MHz with 12-clock operation
- Parallel programming with 87C51 compatible hardware interface to programmer
- RAM expandable externally to 64 kbytes
- Programmable Counter Array (PCA)
 - PWM
 - Capture/compare
- PLCC, LQFP, or DIP package
- Extended temperature ranges
- Dual Data Pointers
- Security bits (3 bits)
- Encryption array - 64 bytes
- Seven interrupt sources
- 4 interrupt priority levels
- Four 8-bit I/O ports
- Full-duplex enhanced UART
 - Framing error detection
 - Automatic address recognition
- Three 16-bit timers/counters T0, T1 (standard 80C51) and additional T2 (capture and compare)
- Programmable clock-out pin
- Asynchronous port reset
- Low EMI (inhibit ALE, slew rate controlled outputs, and 6-clock mode)
- Wake-up from Power Down by an external interrupt

80C51 8-bit microcontroller family 8KB/16KB/32KB/64KB OTP
with 512B/1KB RAM, low voltage (2.7 to 5.5 V), low power, high
speed (30/33 MHz)

P87C51RA2/RB2/RC2/RD2

SELECTION TABLE

| Type | Memory | | | | Timers | | | | Serial Interfaces | | | | ADC bits/ch. | I/O Pins | Interrupts (Ext.)/Levels | Program Security | Default Clock Rate | Optional Clock Rate | Reset active low/high? | Max. Freq. at 6-clk / 12-clk (MHz) | Freq. Range at 3V (MHz) | Freq. Range at 5V (MHz) |
|-----------|--------|-----|-----|-------|-------------|-----|-----|----|-------------------|------------------|-----|-----|--------------|----------|--------------------------|------------------|--------------------|---------------------|------------------------|------------------------------------|-------------------------|-------------------------|
| | RAM | ROM | OTP | Flash | # of Timers | PWM | PCA | WD | UART | I ² C | CAN | SPI | | | | | | | | | | |
| P87C51RD2 | 1K | – | 64K | – | 4 | √ | √ | √ | √ | – | – | – | – | 32 | 7(2)/4 | √ | 12-clk | 6-clk | H | 30/33 | 0-16 | 0-30/33 |
| P87C51RC2 | 512B | – | 32K | – | 4 | √ | √ | √ | √ | – | – | – | – | 32 | 7(2)/4 | √ | 12-clk | 6-clk | H | 30/33 | 0-16 | 0-30/33 |
| P87C51RB2 | 512B | – | 16K | – | 4 | √ | √ | √ | √ | – | – | – | – | 32 | 7(2)/4 | √ | 12-clk | 6-clk | H | 30/33 | 0-16 | 0-30/33 |
| P87C51RA2 | 512B | – | 8K | – | 4 | √ | √ | √ | √ | – | – | – | – | 32 | 7(2)/4 | √ | 12-clk | 6-clk | H | 30/33 | 0-16 | 0-30/33 |

ORDERING INFORMATION

| PHILIPS (EXCEPT NORTH AMERICA) PART ORDER NUMBER PART MARKING | MEMORY | | TEMPERATURE RANGE (°C) AND PACKAGE | VOLTAGE RANGE | DWG # |
|--|--------|------|--|---------------|----------|
| | OTP | RAM | | | |
| P87C51RA2BA | 8 KB | 512B | 0 to +70, PLCC | 2.7 to 5.5 V | SOT187-2 |
| P87C51RA2FA | 8 KB | 512B | –40 to +85, PLCC | 2.7 to 5.5 V | SOT187-2 |
| P87C51RA2BBD | 8 KB | 512B | 0 to +70, LQFP | 2.7 to 5.5 V | SOT389-1 |
| P87C51RB2BA | 16 KB | 512B | 0 to +70, PLCC | 2.7 to 5.5 V | SOT187-2 |
| P87C51RB2FA | 16 KB | 512B | –40 to +85, PLCC | 2.7 to 5.5 V | SOT187-2 |
| P87C51RB2BBD | 16 KB | 512B | 0 to +70, LQFP | 2.7 to 5.5 V | SOT389-1 |
| P87C51RB2BN | 16 KB | 512B | 0 to +70, DIP40 | 2.7 to 5.5 V | SOT129-1 |
| P87C51RB2FN | 16 KB | 512B | –40 to +85, DIP40 | 2.7 to 5.5 V | SOT129-1 |
| P87C51RC2BA | 32 KB | 512B | 0 to +70, PLCC | 2.7 to 5.5 V | SOT187-2 |
| P87C51RC2FA | 32 KB | 512B | –40 to +85, PLCC | 2.7 to 5.5 V | SOT187-2 |
| P87C51RC2BBD | 32 KB | 512B | 0 to +70, LQFP | 2.7 to 5.5 V | SOT389-1 |
| P87C51RC2BN | 32 KB | 512B | 0 to +70, DIP40 | 2.7 to 5.5 V | SOT129-1 |
| P87C51RC2FN | 32 KB | 512B | –40 to +85, DIP40 | 2.7 to 5.5 V | SOT129-1 |
| P87C51RD2BA | 64 KB | 1 KB | 0 to +70, PLCC | 2.7 to 5.5 V | SOT187-2 |
| P87C51RD2FA | 64 KB | 1 KB | –40 to +85, PLCC | 2.7 to 5.5 V | SOT187-2 |
| P87C51RD2BBD | 64 KB | 1 KB | 0 to +70, LQFP | 2.7 to 5.5 V | SOT389-1 |
| P87C51RD2FBD | 64 KB | 1 KB | –40 to +85, LQFP | 2.7 to 5.5 V | SOT389-1 |
| P87C51RD2BN | 64 KB | 1 KB | 0 to +70, DIP40 | 2.7 to 5.5 V | SOT129-1 |

80C51 8-bit microcontroller family 8KB/16KB/32KB/64KB OTP with 512B/1KB RAM, low voltage (2.7 to 5.5 V), low power, high speed (30/33 MHz)

P87C51RA2/RB2/RC2/RD2

BLOCK DIAGRAM 1

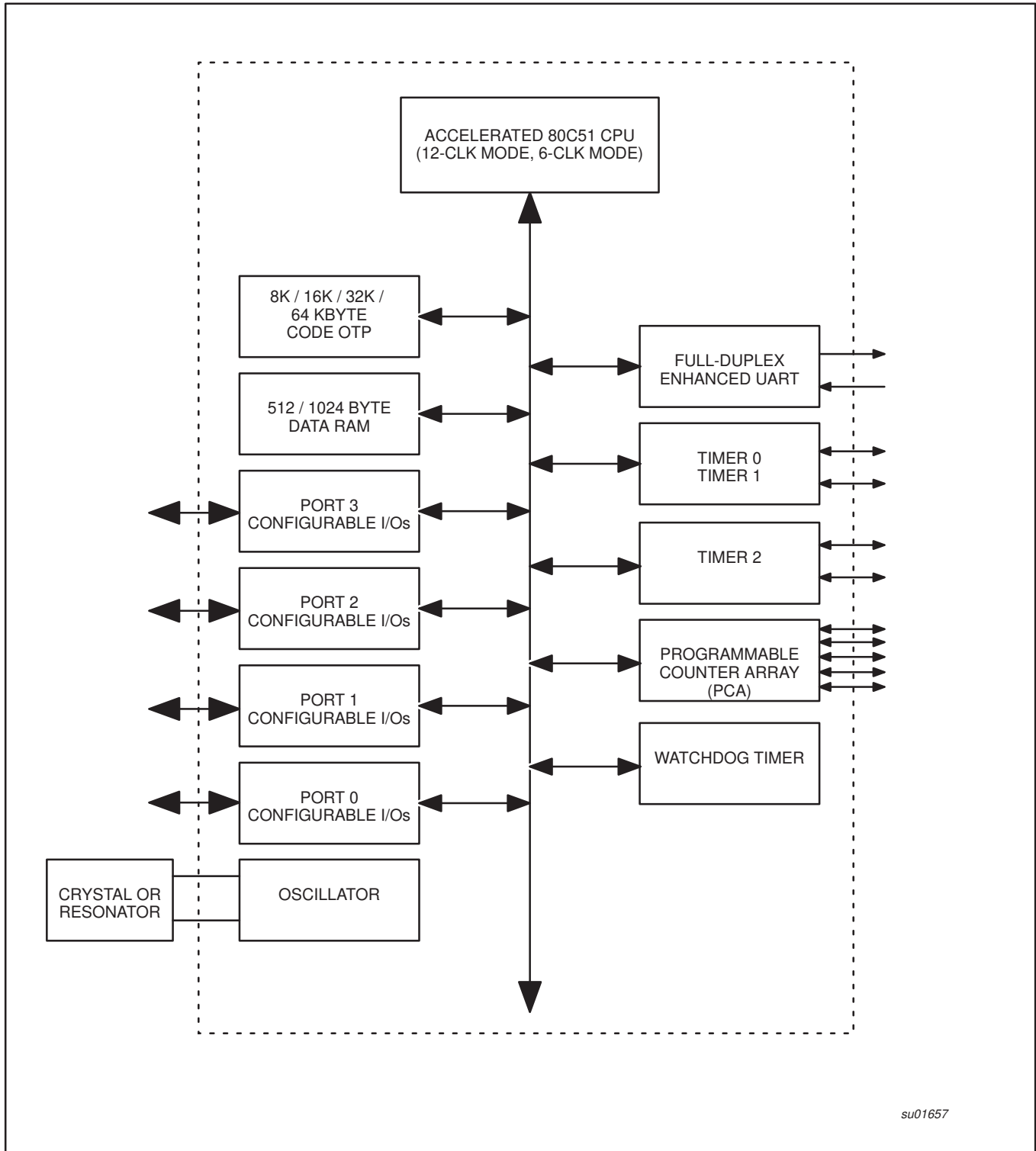

su01657

80C51 8-bit microcontroller family 8KB/16KB/32KB/64KB OTP with 512B/1KB RAM, low voltage (2.7 to 5.5 V), low power, high speed (30/33 MHz)

P87C51RA2/RB2/RC2/RD2

BLOCK DIAGRAM (CPU-ORIENTED)

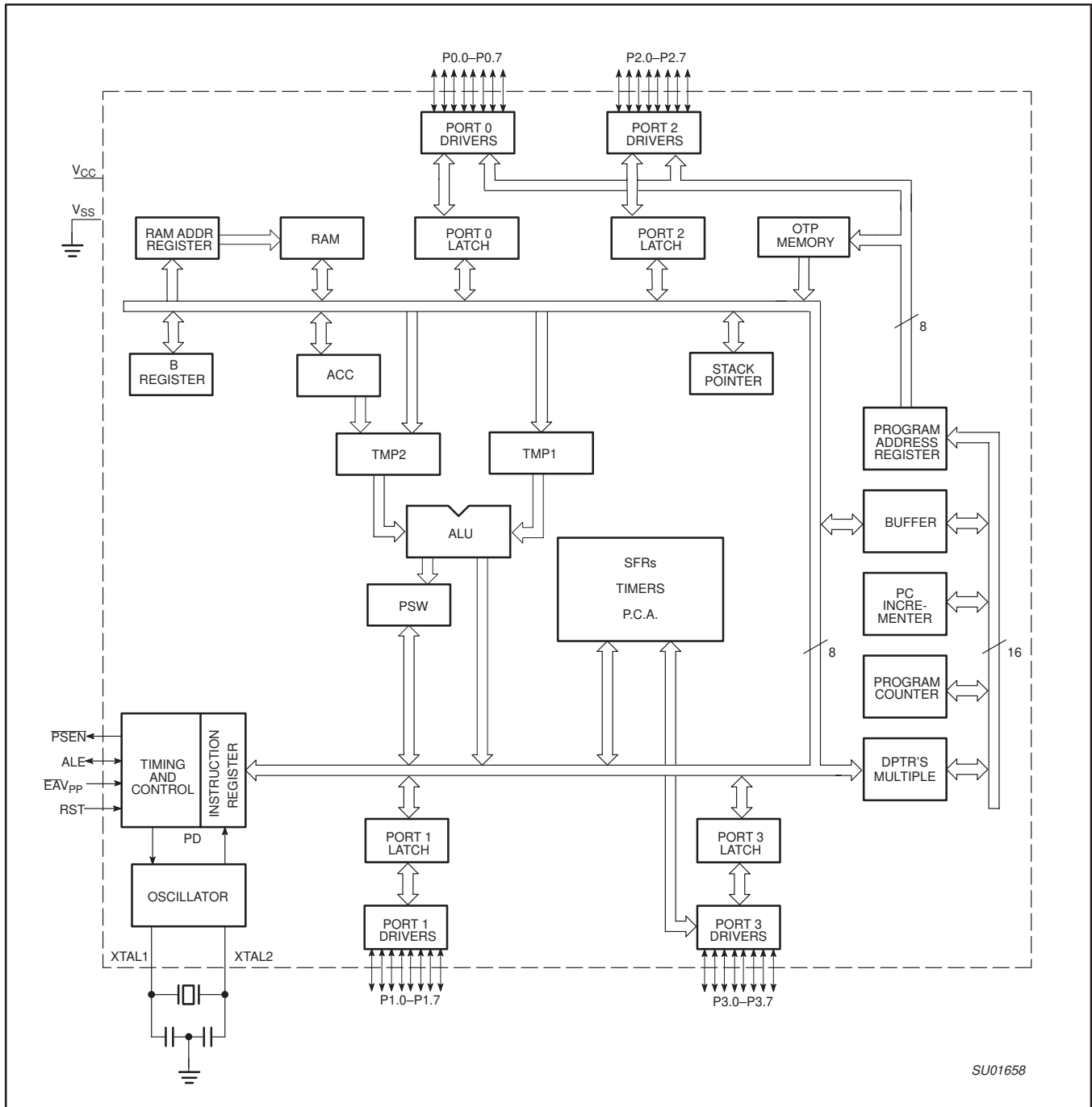

SU01658

80C51 8-bit microcontroller family 8KB/16KB/32KB/64KB OTP with 512B/1KB RAM, low voltage (2.7 to 5.5 V), low power, high speed (30/33 MHz)

P87C51RA2/RB2/RC2/RD2

LOGIC SYMBOL

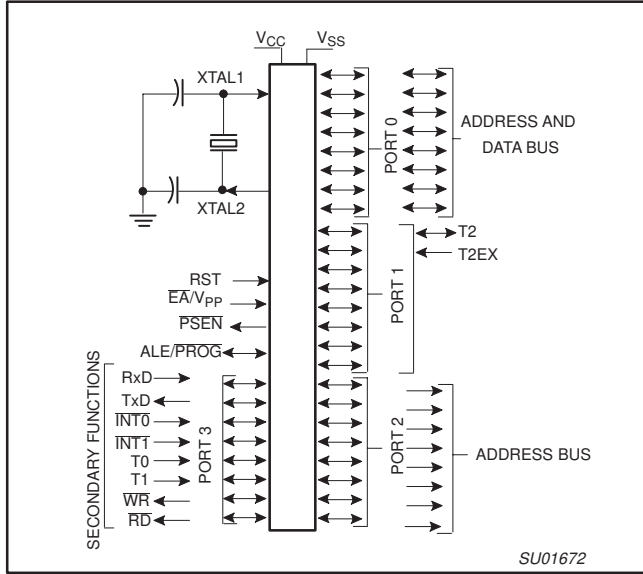

Plastic Leaded Chip Carrier

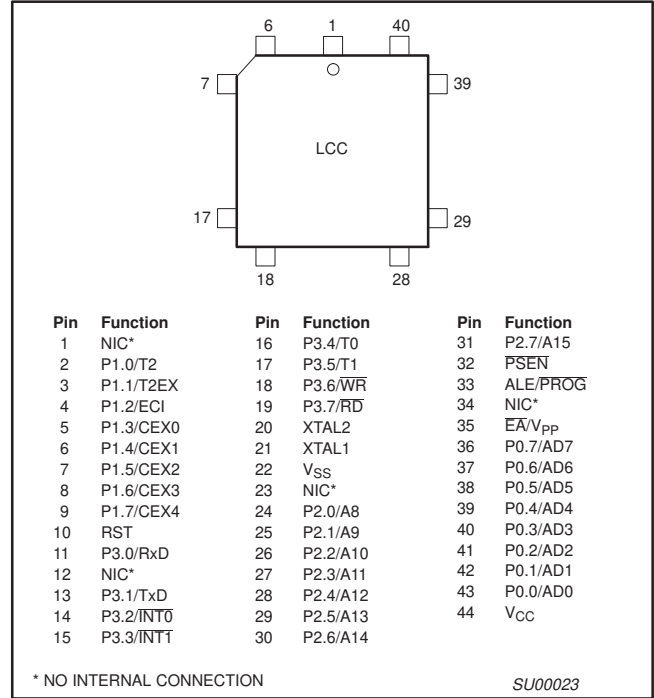

PINNING

Plastic Dual In-Line Package

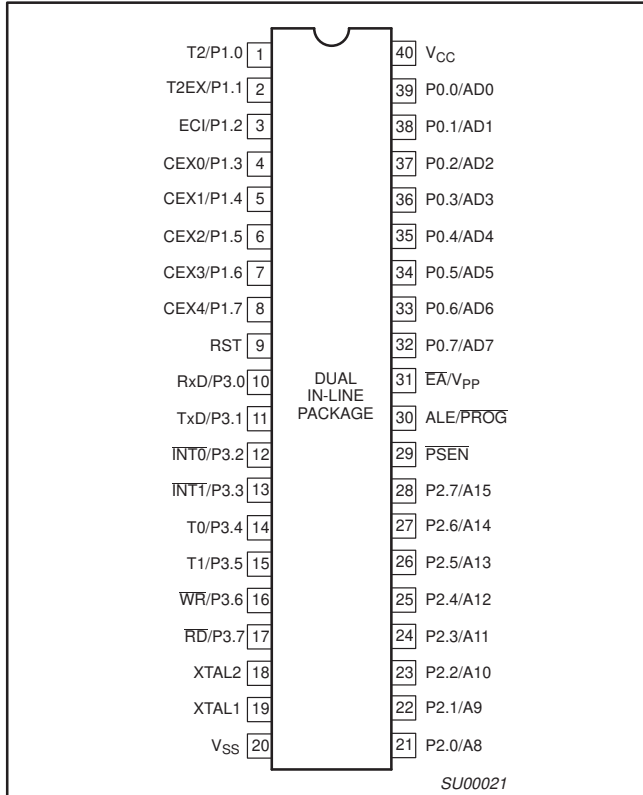

Plastic Quad Flat Pack

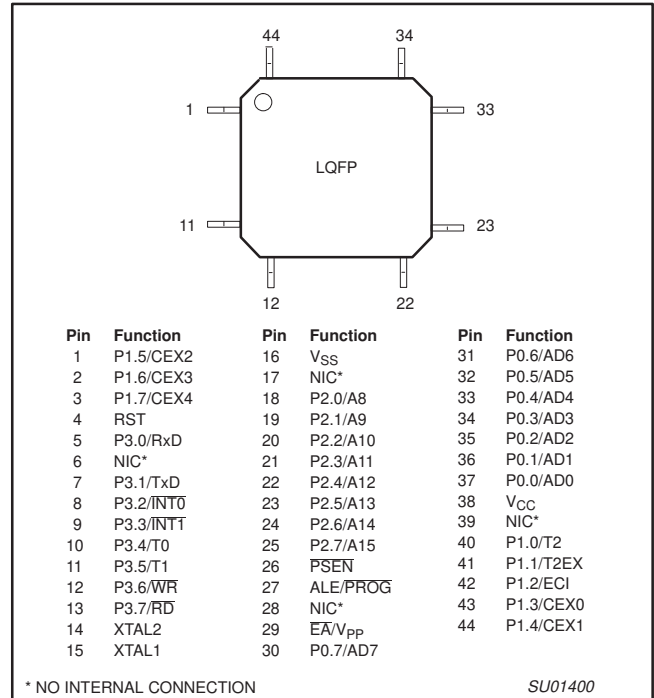

80C51 8-bit microcontroller family 8KB/16KB/32KB/64KB OTP with 512B/1KB RAM, low voltage (2.7 to 5.5 V), low power, high speed (30/33 MHz)

P87C51RA2/RB2/RC2/RD2

PIN DESCRIPTIONS

| MNEMONIC | PIN NUMBER | | | TYPE | NAME AND FUNCTION |
|-----------------|------------|--------------|---------------|------|--|
| | PDIP | PLCC | LQFP | | |
| V _{SS} | 20 | 22 | 16 | I | Ground: 0 V reference. |
| V _{CC} | 40 | 44 | 38 | I | Power Supply: This is the power supply voltage for normal, idle, and power-down operation. |
| P0.0–0.7 | 39–32 | 43–36 | 37–30 | I/O | Port 0: Port 0 is an open-drain, bidirectional I/O port. Port 0 pins that have 1s written to them float and can be used as high-impedance inputs. Port 0 is also the multiplexed low-order address and data bus during accesses to external program and data memory. In this application, it uses strong internal pull-ups when emitting 1s. |
| P1.0–P1.7 | 1–8 | 2–9 | 40–44, 1–3 | I/O | Port 1: Port 1 is an 8-bit bidirectional I/O port with internal pull-ups on all pins. Port 1 pins that have 1s written to them are pulled high by the internal pull-ups and can be used as inputs. As inputs, port 1 pins that are externally pulled low will source current because of the internal pull-ups. (See DC Electrical Characteristics: I _{IL}). Alternate functions for P87C51RA2/RB2/RC2/RD2 Port 1 include: T2 (P1.0): Timer/Counter 2 external count input/Clockout (see Programmable Clock-Out) T2EX (P1.1): Timer/Counter 2 Reload/Capture/Direction Control ECI (P1.2): External Clock Input to the PCA CEX0 (P1.3): Capture/Compare External I/O for PCA module 0 CEX1 (P1.4): Capture/Compare External I/O for PCA module 1 CEX2 (P1.5): Capture/Compare External I/O for PCA module 2 CEX3 (P1.6): Capture/Compare External I/O for PCA module 3 CEX4 (P1.7): Capture/Compare External I/O for PCA module 4 |
| | | | | | |
| | 2 | 3 | 41 | I | |
| | 3 | 4 | 42 | I | |
| | 4 | 5 | 43 | I/O | |
| | 5 | 6 | 44 | I/O | |
| | 6 | 7 | 1 | I/O | |
| | 7 | 8 | 2 | I/O | |
| | 8 | 9 | 3 | I/O | |
| P2.0–P2.7 | 21–28 | 24–31 | 18–25 | I/O | Port 2: Port 2 is an 8-bit bidirectional I/O port with internal pull-ups. Port 2 pins that have 1s written to them are pulled high by the internal pull-ups and can be used as inputs. As inputs, port 2 pins that are externally being pulled low will source current because of the internal pull-ups. (See DC Electrical Characteristics: I _{IL}). Port 2 emits the high-order address byte during fetches from external program memory and during accesses to external data memory that use 16-bit addresses (MOVX @DPTR). In this application, it uses strong internal pull-ups when emitting 1s. During accesses to external data memory that use 8-bit addresses (MOV @Ri), port 2 emits the contents of the P2 special function register. |
| P3.0–P3.7 | 10–17 | 11, 13–19 | 5, 7–13 | I/O | Port 3: Port 3 is an 8-bit bidirectional I/O port with internal pull-ups. Port 3 pins that have 1s written to them are pulled high by the internal pull-ups and can be used as inputs. As inputs, port 3 pins that are externally being pulled low will source current because of the pull-ups. (See DC Electrical Characteristics: I _{IL}). Port 3 also serves the special features of the P87C51RA2/RB2/RC2/RD2, as listed below: RxD (P3.0): Serial input port TxD (P3.1): Serial output port INT0 (P3.2): External interrupt INT1 (P3.3): External interrupt T0 (P3.4): Timer 0 external input T1 (P3.5): Timer 1 external input WR (P3.6): External data memory write strobe RD (P3.7): External data memory read strobe |
| | | | | | |
| | 11 | 13 | 7 | O | |
| | 12 | 14 | 8 | I | |
| | 13 | 15 | 9 | I | |
| | 14 | 16 | 10 | I | |
| | 15 | 17 | 11 | I | |
| | 16 | 18 | 12 | O | |
| | 17 | 19 | 13 | O | |
| RST | 9 | 10 | 4 | I | Reset: A high on this pin for two machine cycles while the oscillator is running, resets the device. An internal resistor to V _{SS} permits a power-on reset using only an external capacitor to V _{CC} . |
| ALE | 30 | 33 | 27 | O | Address Latch Enable: Output pulse for latching the low byte of the address during an access to external memory. In normal operation, ALE is emitted twice every machine cycle, and can be used for external timing or clocking. Note that one ALE pulse is skipped during each access to external data memory. ALE can be disabled by setting SFR auxiliary.0. With this bit set, ALE will be active only during a MOVX instruction. |

80C51 8-bit microcontroller family 8KB/16KB/32KB/64KB OTP
with 512B/1KB RAM, low voltage (2.7 to 5.5 V), low power, high
speed (30/33 MHz)

P87C51RA2/RB2/RC2/RD2

| MNEMONIC | PIN NUMBER | | | TYPE | NAME AND FUNCTION |
|------------------------------|------------|------|------|------|--|
| | PDIP | PLCC | LQFP | | |
| PSEN | 29 | 32 | 26 | O | Program Store Enable: The read strobe to external program memory. When executing code from the external program memory, PSEN is activated twice each machine cycle, except that two PSEN activations are skipped during each access to external data memory. PSEN is not activated during fetches from internal program memory. |
| E \bar{A} /V _{PP} | 31 | 35 | 29 | I | External Access Enable/Programming Supply Voltage: E \bar{A} must be externally held low to enable the device to fetch code from external program memory locations. If E \bar{A} is held high, the device executes from internal program memory. The value on the E \bar{A} pin is latched when RST is released and any subsequent changes have no effect. This pin also receives the programming supply voltage (V _{PP}) during programming. |
| XTAL1 | 19 | 21 | 15 | I | Crystal 1: Input to the inverting oscillator amplifier and input to the internal clock generator circuits. |
| XTAL2 | 18 | 20 | 14 | O | Crystal 2: Output from the inverting oscillator amplifier. |

NOTE:

To avoid "latch-up" effect at power-on, the voltage on any pin (other than V_{PP}) must not be higher than V_{CC} + 0.5 V or less than V_{SS} - 0.5 V.

80C51 8-bit microcontroller family 8KB/16KB/32KB/64KB OTP
with 512B/1KB RAM, low voltage (2.7 to 5.5 V), low power, high
speed (30/33 MHz)

P87C51RA2/RB2/RC2/RD2

SPECIAL FUNCTION REGISTERS

| SYMBOL | DESCRIPTION | DIRECT ADDRESS | BIT ADDRESS, SYMBOL, OR ALTERNATIVE PORT FUNCTION | | | | | | | | RESET VALUE |
|--------------------|-------------------------|----------------|---|-------|------|------|------|------|--------|------|-------------|
| | | | MSB | | | | LSB | | | | |
| ACC* | Accumulator | E0H | E7 | E6 | E5 | E4 | E3 | E2 | E1 | E0 | 00H |
| AUXR# | Auxiliary | 8EH | – | – | – | – | – | – | EXTRAM | AO | xxxxxx00B |
| AUXR1# | Auxiliary 1 | A2H | – | – | – | – | GF2 | 0 | – | DPS | xxxxxx00B |
| B* | B register | F0H | F7 | F6 | F5 | F4 | F3 | F2 | F1 | F0 | 00H |
| CCAP0H# | Module 0 Capture High | FAH | | | | | | | | | xxxxxxxxB |
| CCAP1H# | Module 1 Capture High | FBH | | | | | | | | | xxxxxxxxB |
| CCAP2H# | Module 2 Capture High | FCH | | | | | | | | | xxxxxxxxB |
| CCAP3H# | Module 3 Capture High | FDH | | | | | | | | | xxxxxxxxB |
| CCAP4H# | Module 4 Capture High | FEH | | | | | | | | | xxxxxxxxB |
| CCAP0L# | Module 0 Capture Low | EAH | | | | | | | | | xxxxxxxxB |
| CCAP1L# | Module 1 Capture Low | EBH | | | | | | | | | xxxxxxxxB |
| CCAP2L# | Module 2 Capture Low | ECH | | | | | | | | | xxxxxxxxB |
| CCAP3L# | Module 3 Capture Low | EDH | | | | | | | | | xxxxxxxxB |
| CCAP4L# | Module 4 Capture Low | EEH | | | | | | | | | xxxxxxxxB |
| CCAPM0# | Module 0 Mode | DAH | – | ECOM | CAPP | CAPN | MAT | TOG | PWM | ECCF | x0000000B |
| CCAPM1# | Module 1 Mode | DBH | – | ECOM | CAPP | CAPN | MAT | TOG | PWM | ECCF | x0000000B |
| CCAPM2# | Module 2 Mode | DCH | – | ECOM | CAPP | CAPN | MAT | TOG | PWM | ECCF | x0000000B |
| CCAPM3# | Module 3 Mode | DDH | – | ECOM | CAPP | CAPN | MAT | TOG | PWM | ECCF | x0000000B |
| CCAPM4# | Module 4 Mode | DEH | – | ECOM | CAPP | CAPN | MAT | TOG | PWM | ECCF | x0000000B |
| CCON*# | PCA Counter Control | D8H | DF | DE | DD | DC | DB | DA | D9 | D8 | 00x00000B |
| | | | CF | CR | – | CCF4 | CCF3 | CCF2 | CCF1 | CCF0 | |
| CH# | PCA Counter High | F9H | | | | | | | | | 00H |
| CKCON# | Clock control | 8FH | – | – | – | – | – | – | – | X2 | x0000000B |
| CL# | PCA Counter Low | E9H | | | | | | | | | 00H |
| CMOD# | PCA Counter Mode | D9H | CIDL | WDTE | – | – | – | CPS1 | CPS0 | ECF | 00xxx000B |
| DPTR: | Data Pointer (2 bytes) | 83H | | | | | | | | | 00H |
| | | | 82H | | | | | | | | |
| IE* | Interrupt Enable 0 | A8H | | AF | AE | AD | AC | AB | AA | A9 | A8 |
| | | | EA | EC | ET2 | ES | ET1 | EX1 | ET0 | EX0 | |
| IP* | Interrupt Priority | B8H | BF | BE | BD | BC | BB | BA | B9 | B8 | x0000000B |
| | | | – | PPC | PT2 | PS | PT1 | PX1 | PT0 | PX0 | |
| IPH# | Interrupt Priority High | B7H | B7 | B6 | B5 | B4 | B3 | B2 | B1 | B0 | x0000000B |
| | | | – | PPCH | PT2H | PSH | PT1H | PX1H | PT0H | PX0H | |
| P0* | Port 0 | 80H | 87 | 86 | 85 | 84 | 83 | 82 | 81 | 80 | FFH |
| | | | AD7 | AD6 | AD5 | AD4 | AD3 | AD2 | AD1 | AD0 | |
| P1* | Port 1 | 90H | 97 | 96 | 95 | 94 | 93 | 92 | 91 | 90 | FFH |
| | | | CEX4 | CEX3 | CEX2 | CEX1 | CEX0 | ECI | T2EX | T2 | |
| P2* | Port 2 | A0H | A7 | A6 | A5 | A4 | A3 | A2 | A1 | A0 | FFH |
| | | | AD15 | AD14 | AD13 | AD12 | AD11 | AD10 | AD9 | AD8 | |
| P3* | Port 3 | B0H | B7 | B6 | B5 | B4 | B3 | B2 | B1 | B0 | FFH |
| | | | RD | WR | T1 | T0 | INT1 | INT0 | TxD | RxD | |
| PCON# ¹ | Power Control | 87H | SMOD1 | SMOD0 | – | POF | GF1 | GF0 | PD | IDL | 00xxx000B |

* SFRs are bit addressable.
SFRs are modified from or added to the 80C51 SFRs.
– Reserved bits.
1. Reset value depends on reset source.

80C51 8-bit microcontroller family 8KB/16KB/32KB/64KB OTP
with 512B/1KB RAM, low voltage (2.7 to 5.5 V), low power, high
speed (30/33 MHz)

P87C51RA2/RB2/RC2/RD2

SPECIAL FUNCTION REGISTERS (Continued)

| SYMBOL | DESCRIPTION | DIRECT ADDRESS | BIT ADDRESS, SYMBOL, OR ALTERNATIVE PORT FUNCTION | | | | | | | | RESET VALUE |
|---------|----------------------|----------------|---|------|------|------|-------|-----|------|--------|---|
| | | | MSB | | | | LSB | | | | |
| PSW* | Program Status Word | D0H | D7 | D6 | D5 | D4 | D3 | D2 | D1 | D0 | 0000000B 00H 00H |
| RCAP2H# | Timer 2 Capture High | CBH | CY | AC | F0 | RS1 | RS0 | OV | F1 | P | |
| RCAP2L# | Timer 2 Capture Low | CAH | | | | | | | | | |
| SADDR# | Slave Address | A9H | | | | | | | | | 00H 00H |
| SADEN# | Slave Address Mask | B9H | | | | | | | | | |
| SBUF | Serial Data Buffer | 99H | | | | | | | | | xxxxxxxB |
| SCON* | Serial Control | 98H | 9F | 9E | 9D | 9C | 9B | 9A | 99 | 98 | 00H 07H |
| SP | Stack Pointer | 81H | SM0/FE | SM1 | SM2 | REN | TB8 | RB8 | TI | RI | |
| TCON* | Timer Control | 88H | 8F | 8E | 8D | 8C | 8B | 8A | 89 | 88 | 00H |
| | | | TF1 | TR1 | TF0 | TR0 | IE1 | IT1 | IE0 | IT0 | |
| T2CON* | Timer 2 Control | C8H | CF | CE | CD | CC | CB | CA | C9 | C8 | 00H xxxxxx00B |
| T2MOD# | Timer 2 Mode Control | C9H | TF2 | EXF2 | RCLK | TCLK | EXEN2 | TR2 | C/T2 | CP/RL2 | |
| TH0 | Timer High 0 | 8CH | - | - | - | - | - | - | T2OE | DCEN | 00H 00H 00H 00H 00H 00H 00H |
| TH1 | Timer High 1 | 8DH | | | | | | | | | |
| TH2# | Timer High 2 | CDH | | | | | | | | | |
| TL0 | Timer Low 0 | 8AH | | | | | | | | | |
| TL1 | Timer Low 1 | 8BH | | | | | | | | | |
| TL2# | Timer Low 2 | CCH | | | | | | | | | |
| | | | | | | | | | | | |
| TMOD | Timer Mode | 89H | GATE | C/T | M1 | M0 | GATE | C/T | M1 | M0 | 00H |
| WDTRST | Watchdog Timer Reset | A6H | | | | | | | | | |

* SFRs are bit addressable.
SFRs are modified from or added to the 80C51 SFRs.
- Reserved bits.

OSCILLATOR CHARACTERISTICS

XTAL1 and XTAL2 are the input and output, respectively, of an inverting amplifier. The pins can be configured for use as an on-chip oscillator.

To drive the device from an external clock source, XTAL1 should be driven while XTAL2 is left unconnected. Minimum and maximum high and low times specified in the data sheet must be observed.

This device is configured at the factory to operate using 12 clock periods per machine cycle, referred to in this datasheet as "12-clock mode". It may be optionally configured on commercially available parallel programming equipment or via software to operate at 6 clocks per machine cycle, referred to in this datasheet as "6-clock mode". (This yields performance equivalent to twice that of standard 80C51 family devices). Also see next page.

80C51 8-bit microcontroller family 8KB/16KB/32KB/64KB OTP with 512B/1KB RAM, low voltage (2.7 to 5.5 V), low power, high speed (30/33 MHz)

P87C51RA2/RB2/RC2/RD2

CLOCK CONTROL REGISTER (CKCON)

This device allows control of the 6-clock/12-clock mode by means of both an SFR bit (X2) and an OTP bit. The OTP clock control bit

OX2, when programmed (6-clock mode), supersedes the X2 bit (CKCON.0). The CKCON register is shown below in Figure 1.

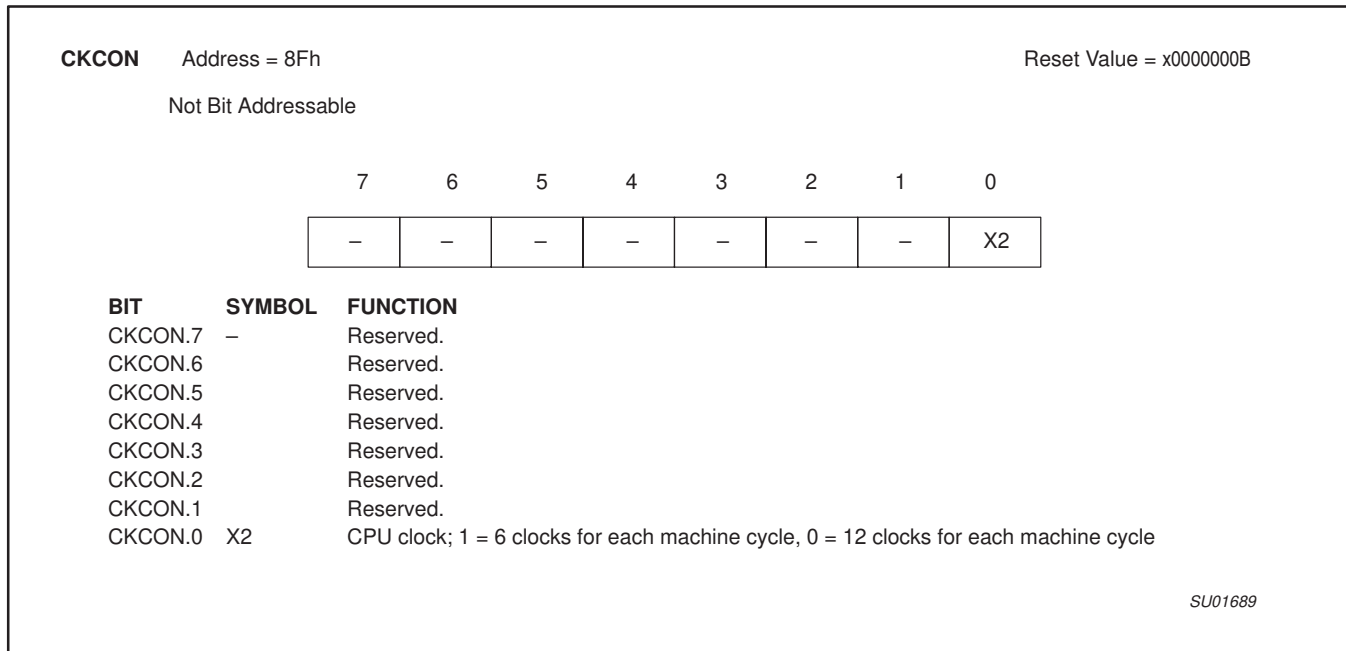

Figure 1. Clock control (CKCON) register

Also please note that the clock divider applies to the serial port for modes 0 & 2 (fixed baud rate modes). This is because modes 1 & 3 (variable baud rate modes) use either Timer 1 or Timer 2.

Below is the truth table for the CPU clock mode.

Table 1.

| OX2 clock mode bit (can only be set by parallel programmer) | X2 bit (CKCON.0) | CPU clock mode |
|---|------------------|-------------------------|
| erased | 0 | 12-clock mode (default) |
| erased | 1 | 6-clock mode |
| programmed | X | 6-clock mode |

RESET

A reset is accomplished by holding the RST pin high for at least two machine cycles (12 oscillator periods in 6-clock mode, or 24 oscillator periods in 12-clock mode), while the oscillator is running. To ensure a good power-on reset, the RST pin must be high long enough to allow the oscillator time to start up (normally a few milliseconds) plus two machine cycles. At power-on, the voltage on V_{CC} and RST must come up at the same time for a proper start-up. Ports 1, 2, and 3 will asynchronously be driven to their reset condition when a voltage above V_{IH1} (min.) is applied to RST.

The value on the E_A pin is latched when RST is deasserted and has no further effect.

80C51 8-bit microcontroller family 8KB/16KB/32KB/64KB OTP with 512B/1KB RAM, low voltage (2.7 to 5.5 V), low power, high speed (30/33 MHz)

P87C51RA2/RB2/RC2/RD2

LOW POWER MODES

Stop Clock Mode

The static design enables the clock speed to be reduced down to 0 MHz (stopped). When the oscillator is stopped, the RAM and Special Function Registers retain their values. This mode allows step-by-step utilization and permits reduced system power consumption by lowering the clock frequency down to any value. For lowest power consumption the Power Down mode is suggested.

Idle Mode

In the idle mode (see Table 2), the CPU puts itself to sleep while all of the on-chip peripherals stay active. The instruction to invoke the idle mode is the last instruction executed in the normal operating mode before the idle mode is activated. The CPU contents, the on-chip RAM, and all of the special function registers remain intact during this mode. The idle mode can be terminated either by any enabled interrupt (at which time the process is picked up at the interrupt service routine and continued), or by a hardware reset which starts the processor in the same manner as a power-on reset.

Power-Down Mode

To save even more power, a Power Down mode (see Table 2) can be invoked by software. In this mode, the oscillator is stopped and the instruction that invoked Power Down is the last instruction executed. The on-chip RAM and Special Function Registers retain their values down to 2 V and care must be taken to return V_{CC} to the minimum specified operating voltages before the Power Down Mode is terminated.

Either a hardware reset or external interrupt can be used to exit from Power Down. Reset redefines all the SFRs but does not change the on-chip RAM. An external interrupt allows both the SFRs and the on-chip RAM to retain their values.

To properly terminate Power Down, the reset or external interrupt should not be executed before V_{CC} is restored to its normal operating level and must be held active long enough for the oscillator to restart and stabilize (normally less than 10 ms).

With an external interrupt, INT0 and INT1 must be enabled and configured as level-sensitive. Holding the pin low restarts the oscillator but bringing the pin back high completes the exit. Once the interrupt is serviced, the next instruction to be executed after RETI will be the one following the instruction that put the device into Power Down.

POWER-ON FLAG

The Power-On Flag (POF) is set by on-chip circuitry when the V_{CC} level on the P87C51RA2/RB2/RC2/RD2 rises from 0 to 5 V. The POF bit can be set or cleared by software allowing a user to determine if the reset is the result of a power-on or a warm start after powerdown. The V_{CC} level must remain above 3 V for the POF to remain unaffected by the V_{CC} level.

Design Consideration

When the idle mode is terminated by a hardware reset, the device normally resumes program execution, from where it left off, up to two machine cycles before the internal reset algorithm takes control. On-chip hardware inhibits access to internal RAM in this event, but access to the port pins is not inhibited. To eliminate the possibility of an unexpected write when Idle is terminated by reset, the instruction following the one that invokes Idle should not be one that writes to a port pin or to external memory.

ONCE™ Mode

The ONCE (“On-Circuit Emulation”) Mode facilitates testing and debugging of systems without the device having to be removed from the circuit. The ONCE Mode is invoked by:

1. Pull ALE low while the device is in reset and PSEN is high;
2. Hold ALE low as RST is deactivated.

While the device is in ONCE Mode, the Port 0 pins go into a float state, and the other port pins and ALE and PSEN are weakly pulled high. The oscillator circuit remains active. While the device is in this mode, an emulator or test CPU can be used to drive the circuit. Normal operation is restored when a normal reset is applied.

Programmable Clock-Out

A 50% duty cycle clock can be programmed to come out on P1.0. This pin, besides being a regular I/O pin, has two alternate functions. It can be programmed:

1. to input the external clock for Timer/Counter 2, or
2. to output a 50% duty cycle clock ranging from 61 Hz to 4 MHz at a 16 MHz operating frequency in 12-clock mode (122 Hz to 8 MHz in 6-clock mode).

To configure the Timer/Counter 2 as a clock generator, bit C/T2 (in T2CON) must be cleared and bit T20E in T2MOD must be set. Bit TR2 (T2CON.2) also must be set to start the timer.

The Clock-Out frequency depends on the oscillator frequency and the reload value of Timer 2 capture registers (RCAP2H, RCAP2L) as shown in this equation:

$$n = \frac{\text{Oscillator Frequency}}{n \times (65536 - \text{RCAP2H, RCAP2L})}$$

n = 2 in 6-clock mode
4 in 12-clock mode

Where (RCAP2H,RCAP2L) = the content of RCAP2H and RCAP2L taken as a 16-bit unsigned integer.

In the Clock-Out mode Timer 2 roll-overs will not generate an interrupt. This is similar to when it is used as a baud-rate generator. It is possible to use Timer 2 as a baud-rate generator and a clock generator simultaneously. Note, however, that the baud-rate and the Clock-Out frequency will be the same.

Table 2. External Pin Status During Idle and Power-Down Mode

| MODE | PROGRAM MEMORY | ALE | PSEN | PORT 0 | PORT 1 | PORT 2 | PORT 3 |
|------------|----------------|-----|------|--------|--------|---------|--------|
| Idle | Internal | 1 | 1 | Data | Data | Data | Data |
| Idle | External | 1 | 1 | Float | Data | Address | Data |
| Power-down | Internal | 0 | 0 | Data | Data | Data | Data |
| Power-down | External | 0 | 0 | Float | Data | Data | Data |

80C51 8-bit microcontroller family 8KB/16KB/32KB/64KB OTP with 512B/1KB RAM, low voltage (2.7 to 5.5 V), low power, high speed (30/33 MHz)

P87C51RA2/RB2/RC2/RD2

TIMER 0 AND TIMER 1 OPERATION

Timer 0 and Timer 1

The “Timer” or “Counter” function is selected by control bits C/T in the Special Function Register TMOD. These two Timer/Counters have four operating modes, which are selected by bit-pairs (M1, M0) in TMOD. Modes 0, 1, and 2 are the same for both Timers/Counters. Mode 3 is different. The four operating modes are described in the following text.

Mode 0

Putting either Timer into Mode 0 makes it look like an 8048 Timer, which is an 8-bit Counter with a divide-by-32 prescaler. Figure 3 shows the Mode 0 operation.

In this mode, the Timer register is configured as a 13-bit register. As the count rolls over from all 1s to all 0s, it sets the Timer interrupt flag TF_n. The counted input is enabled to the Timer when TR_n = 1 and either GATE = 0 or INT_n = 1. (Setting GATE = 1 allows the Timer to be controlled by external input INT_n, to facilitate pulse width measurements). TR_n is a control bit in the Special Function Register TCON (Figure 4).

The 13-bit register consists of all 8 bits of TH_n and the lower 5 bits of TL_n. The upper 3 bits of TL_n are indeterminate and should be ignored. Setting the run flag (TR_n) does not clear the registers.

Mode 0 operation is the same for Timer 0 as for Timer 1. There are two different GATE bits, one for Timer 1 (TMOD.7) and one for Timer 0 (TMOD.3).

Mode 1

Mode 1 is the same as Mode 0, except that the Timer register is being run with all 16 bits.

Mode 2

Mode 2 configures the Timer register as an 8-bit Counter (TL_n) with automatic reload, as shown in Figure 5. Overflow from TL_n not only sets TF_n, but also reloads TL_n with the contents of TH_n, which is preset by software. The reload leaves TH_n unchanged.

Mode 2 operation is the same for Timer 0 as for Timer 1.

Mode 3

Timer 1 in Mode 3 simply holds its count. The effect is the same as setting TR1 = 0.

Timer 0 in Mode 3 establishes TL0 and TH0 as two separate counters. The logic for Mode 3 on Timer 0 is shown in Figure 6. TL0 uses the Timer 0 control bits: C/T, GATE, TR0, and TF0 as well as pin INT0. TH0 is locked into a timer function (counting machine cycles) and takes over the use of TR1 and TF1 from Timer 1. Thus, TH0 now controls the “Timer 1” interrupt.

Mode 3 is provided for applications requiring an extra 8-bit timer on the counter. With Timer 0 in Mode 3, an 80C51 can look like it has three Timer/Counters. When Timer 0 is in Mode 3, Timer 1 can be turned on and off by switching it out of and into its own Mode 3, or can still be used by the serial port as a baud rate generator, or in fact, in any application not requiring an interrupt.

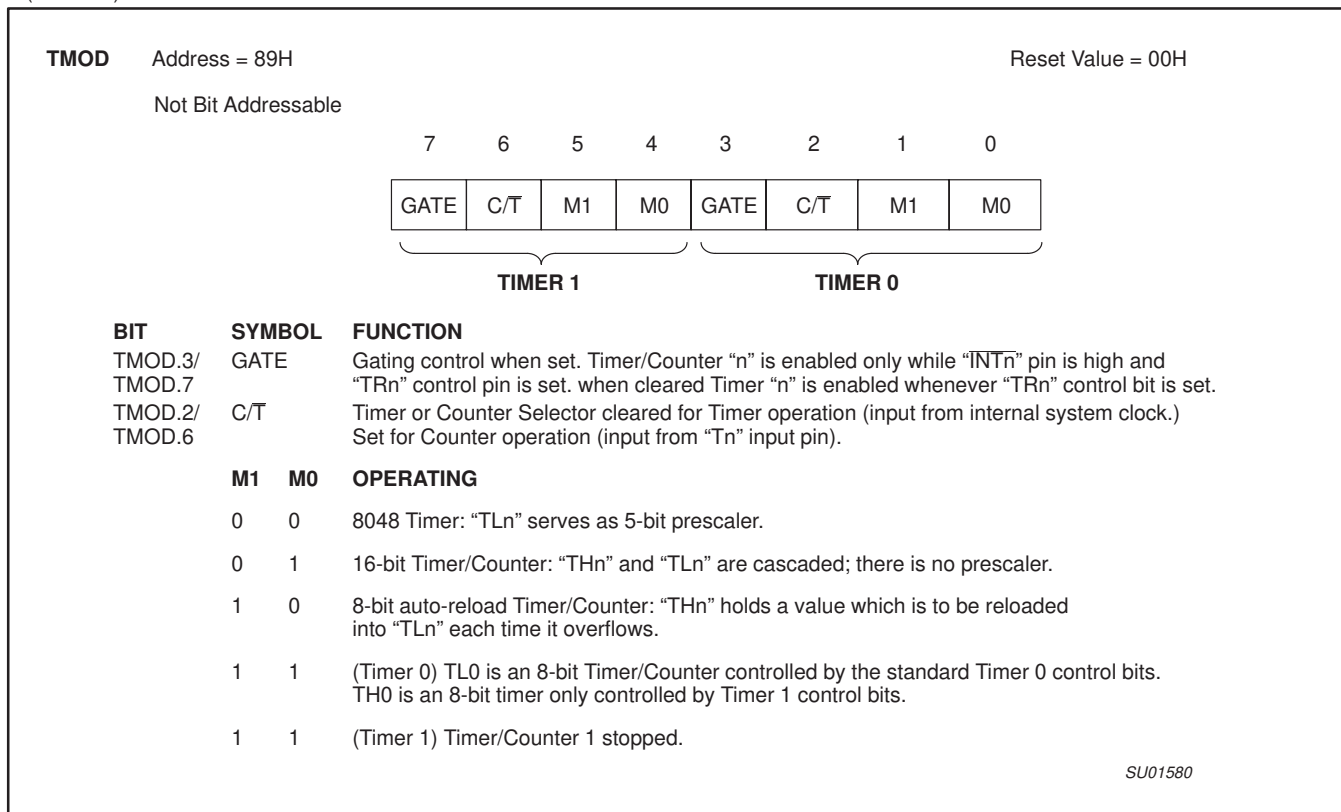

Figure 2. Timer/Counter 0/1 Mode Control (TMOD) Register

80C51 8-bit microcontroller family 8KB/16KB/32KB/64KB OTP with 512B/1KB RAM, low voltage (2.7 to 5.5 V), low power, high speed (30/33 MHz)

P87C51RA2/RB2/RC2/RD2

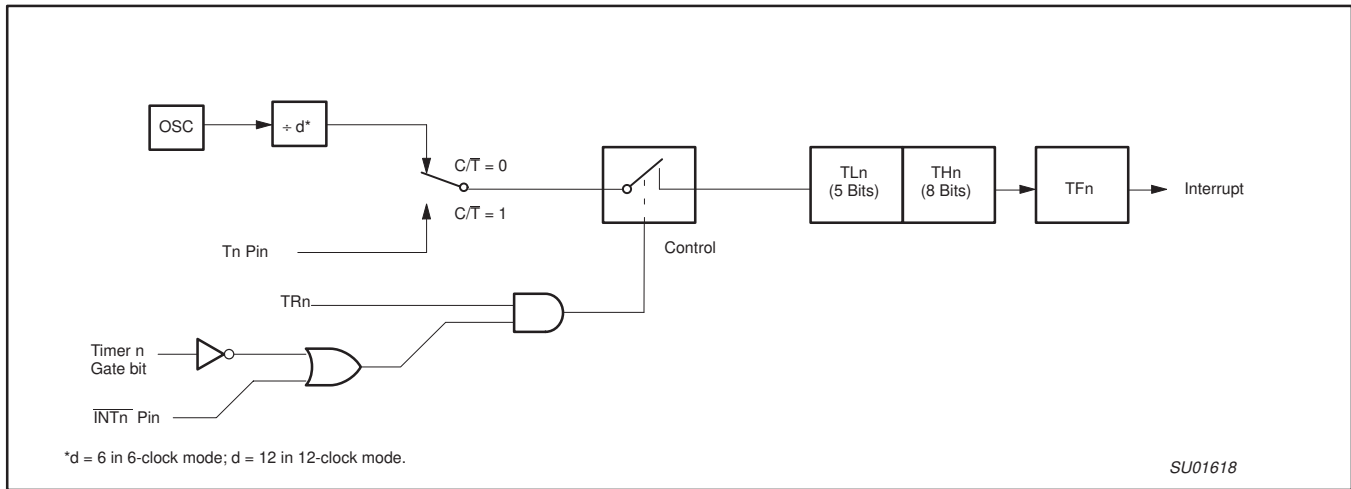

Figure 3. Timer/Counter 0/1 Mode 0: 13-Bit Timer/Counter

TCON Address = 88H Reset Value = 00H
 Bit Addressable

| | | | | | | | | |
|--|-----|-----|-----|-----|-----|-----|-----|-----|
| | 7 | 6 | 5 | 4 | 3 | 2 | 1 | 0 |
| | TF1 | TR1 | TF0 | TR0 | IE1 | IT1 | IE0 | IT0 |

| BIT | SYMBOL | FUNCTION |
|--------|--------|--|
| TCON.7 | TF1 | Timer 1 overflow flag. Set by hardware on Timer/Counter overflow. Cleared by hardware when processor vectors to interrupt routine, or clearing the bit in software. |
| TCON.6 | TR1 | Timer 1 Run control bit. Set/cleared by software to turn Timer/Counter on/off. |
| TCON.5 | TF0 | Timer 0 overflow flag. Set by hardware on Timer/Counter overflow. Cleared by hardware when processor vectors to interrupt routine, or by clearing the bit in software. |
| TCON.4 | TR0 | Timer 0 Run control bit. Set/cleared by software to turn Timer/Counter on/off. |
| TCON.3 | IE1 | Interrupt 1 Edge flag. Set by hardware when external interrupt edge detected. Cleared when interrupt processed. |
| TCON.2 | IT1 | Interrupt 1 type control bit. Set/cleared by software to specify falling edge/low level triggered external interrupts. |
| TCON.1 | IE0 | Interrupt 0 Edge flag. Set by hardware when external interrupt edge detected. Cleared when interrupt processed. |
| TCON.0 | IT0 | Interrupt 0 Type control bit. Set/cleared by software to specify falling edge/low level triggered external interrupts. |

SU01516

Figure 4. Timer/Counter 0/1 Control (TCON) Register

80C51 8-bit microcontroller family 8KB/16KB/32KB/64KB OTP with 512B/1KB RAM, low voltage (2.7 to 5.5 V), low power, high speed (30/33 MHz)

P87C51RA2/RB2/RC2/RD2

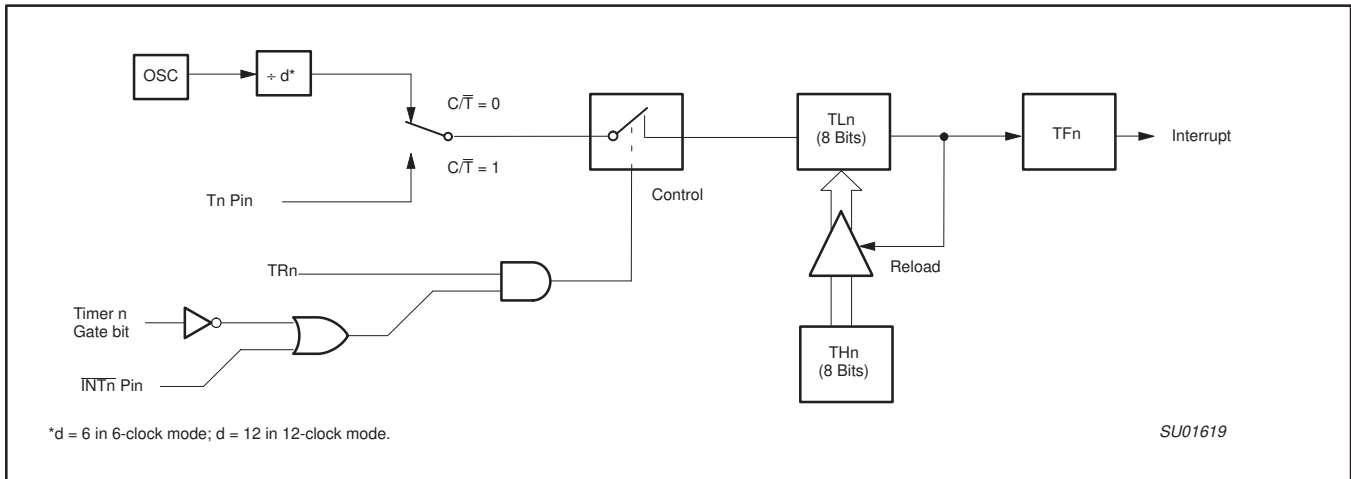

Figure 5. Timer/Counter 0/1 Mode 2: 8-Bit Auto-Reload

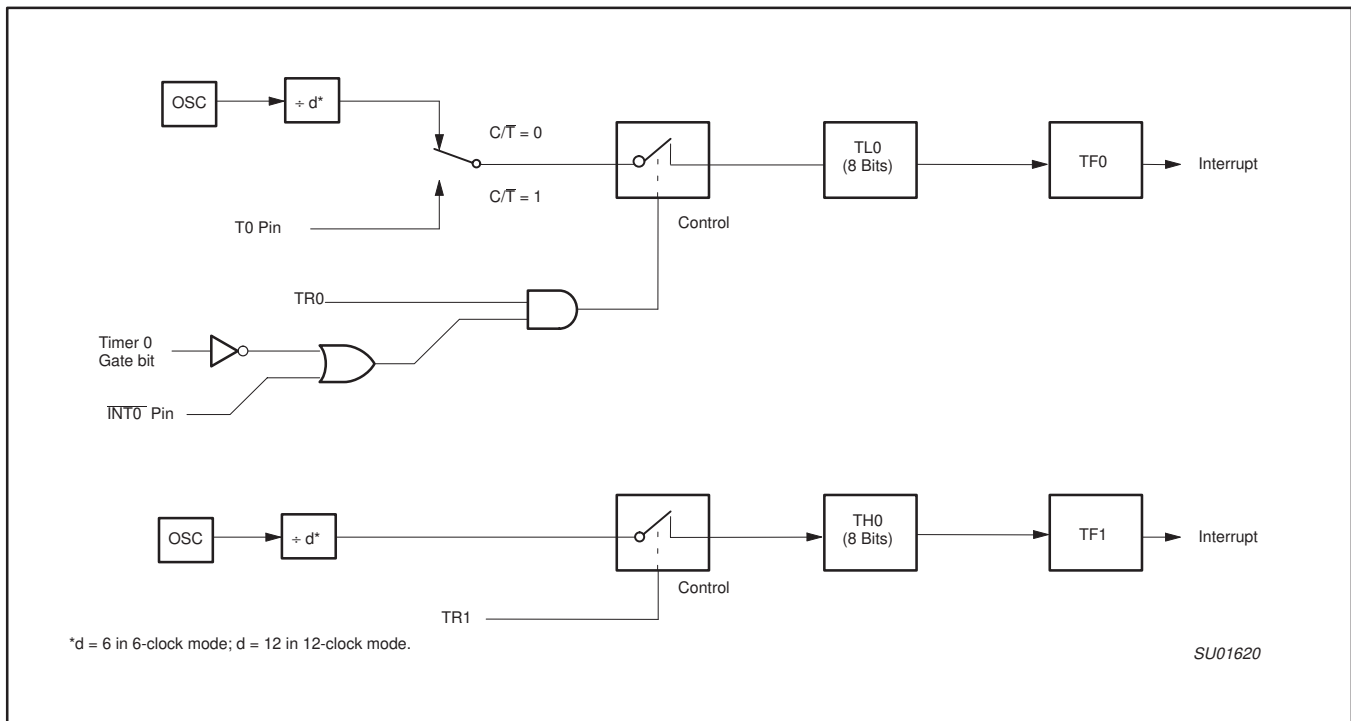

Figure 6. Timer/Counter 0 Mode 3: Two 8-Bit Counters

80C51 8-bit microcontroller family 8KB/16KB/32KB/64KB OTP with 512B/1KB RAM, low voltage (2.7 to 5.5 V), low power, high speed (30/33 MHz)

P87C51RA2/RB2/RC2/RD2

TIMER 2 OPERATION

Timer 2

Timer 2 is a 16-bit Timer/Counter which can operate as either an event timer or an event counter, as selected by C/T2 in the special function register T2CON (see Figure 1). Timer 2 has three operating modes: Capture, Auto-reload (up or down counting), and Baud Rate Generator, which are selected by bits in the T2CON as shown in Table 3.

Capture Mode

In the capture mode there are two options which are selected by bit EXEN2 in T2CON. If EXEN2=0, then timer 2 is a 16-bit timer or counter (as selected by C/T2 in T2CON) which, upon overflowing sets bit TF2, the timer 2 overflow bit. This bit can be used to generate an interrupt (by enabling the Timer 2 interrupt bit in the IE register). If EXEN2= 1, Timer 2 operates as described above, but with the added feature that a 1- to -0 transition at external input T2EX causes the current value in the Timer 2 registers, TL2 and TH2, to be captured into registers RCAP2L and RCAP2H, respectively. In addition, the transition at T2EX causes bit EXF2 in T2CON to be set, and EXF2 like TF2 can generate an interrupt (which vectors to the same location as Timer 2 overflow interrupt. The Timer 2 interrupt service routine can interrogate TF2 and EXF2 to determine which event caused the interrupt). The capture mode is illustrated in Figure 2 (There is no reload value for TL2 and TH2 in this mode. Even when a capture event occurs from T2EX, the counter keeps on counting T2EX pin transitions or osc/6 pulses (osc/12 in 12-clock mode).).

Auto-Reload Mode (Up or Down Counter)

In the 16-bit auto-reload mode, Timer 2 can be configured (as either a timer or counter [C/T2 in T2CON]) then programmed to count up or down. The counting direction is determined by bit DCEN (Down

Counter Enable) which is located in the T2MOD register (see Figure 3). When reset is applied the DCEN=0 which means Timer 2 will default to counting up. If DCEN bit is set, Timer 2 can count up or down depending on the value of the T2EX pin.

Figure 4 shows Timer 2 which will count up automatically since DCEN=0. In this mode there are two options selected by bit EXEN2 in T2CON register. If EXEN2=0, then Timer 2 counts up to 0FFFFH and sets the TF2 (Overflow Flag) bit upon overflow. This causes the Timer 2 registers to be reloaded with the 16-bit value in RCAP2L and RCAP2H. The values in RCAP2L and RCAP2H are preset by software means.

If EXEN2=1, then a 16-bit reload can be triggered either by an overflow or by a 1-to-0 transition at input T2EX. This transition also sets the EXF2 bit. The Timer 2 interrupt, if enabled, can be generated when either TF2 or EXF2 are 1.

In Figure 5 DCEN=1 which enables Timer 2 to count up or down. This mode allows pin T2EX to control the direction of count. When a logic 1 is applied at pin T2EX Timer 2 will count up. Timer 2 will overflow at 0FFFFH and set the TF2 flag, which can then generate an interrupt, if the interrupt is enabled. This timer overflow also causes the 16-bit value in RCAP2L and RCAP2H to be reloaded into the timer registers TL2 and TH2.

When a logic 0 is applied at pin T2EX this causes Timer 2 to count down. The timer will underflow when TL2 and TH2 become equal to the value stored in RCAP2L and RCAP2H. Timer 2 underflow sets the TF2 flag and causes 0FFFFH to be reloaded into the timer registers TL2 and TH2.

The external flag EXF2 toggles when Timer 2 underflows or overflows. This EXF2 bit can be used as a 17th bit of resolution if needed. The EXF2 flag does not generate an interrupt in this mode of operation.

| | | (MSB) | | | | | (LSB) | | |
|--------|----------|--|------|------|------|-------|-------|------|--------|
| | | TF2 | EXF2 | RCLK | TCLK | EXEN2 | TR2 | C/T2 | CP/RL2 |
| Symbol | Position | Name and Significance | | | | | | | |
| TF2 | T2CON.7 | Timer 2 overflow flag set by a Timer 2 overflow and must be cleared by software. TF2 will not be set when either RCLK or TCLK = 1. | | | | | | | |
| EXF2 | T2CON.6 | Timer 2 external flag set when either a capture or reload is caused by a negative transition on T2EX and EXEN2 = 1. When Timer 2 interrupt is enabled, EXF2 = 1 will cause the CPU to vector to the Timer 2 interrupt routine. EXF2 must be cleared by software. EXF2 does not cause an interrupt in up/down counter mode (DCEN = 1). | | | | | | | |
| RCLK | T2CON.5 | Receive clock flag. When set, causes the serial port to use Timer 2 overflow pulses for its receive clock in modes 1 and 3. RCLK = 0 causes Timer 1 overflow to be used for the receive clock. | | | | | | | |
| TCLK | T2CON.4 | Transmit clock flag. When set, causes the serial port to use Timer 2 overflow pulses for its transmit clock in modes 1 and 3. TCLK = 0 causes Timer 1 overflows to be used for the transmit clock. | | | | | | | |
| EXEN2 | T2CON.3 | Timer 2 external enable flag. When set, allows a capture or reload to occur as a result of a negative transition on T2EX if Timer 2 is not being used to clock the serial port. EXEN2 = 0 causes Timer 2 to ignore events at T2EX. | | | | | | | |
| TR2 | T2CON.2 | Start/stop control for Timer 2. A logic 1 starts the timer. | | | | | | | |
| C/T2 | T2CON.1 | Timer or counter select. (Timer 2) 0 = Internal timer (OSC/6 in 6-clock mode or OSC/12 in 12-clock mode) 1 = External event counter (falling edge triggered). | | | | | | | |
| CP/RL2 | T2CON.0 | Capture/Reload flag. When set, captures will occur on negative transitions at T2EX if EXEN2 = 1. When cleared, auto-reloads will occur either with Timer 2 overflows or negative transitions at T2EX when EXEN2 = 1. When either RCLK = 1 or TCLK = 1, this bit is ignored and the timer is forced to auto-reload on Timer 2 overflow. | | | | | | | |

SU01251

Figure 1. Timer/Counter 2 (T2CON) Control Register

80C51 8-bit microcontroller family 8KB/16KB/32KB/64KB OTP with 512B/1KB RAM, low voltage (2.7 to 5.5 V), low power, high speed (30/33 MHz)

P87C51RA2/RB2/RC2/RD2

Table 3. Timer 2 Operating Modes

| RCLK + TCLK | CP/RL2 | TR2 | MODE |
|-------------|--------|-----|---------------------|
| 0 | 0 | 1 | 16-bit Auto-reload |
| 0 | 1 | 1 | 16-bit Capture |
| 1 | X | 1 | Baud rate generator |
| X | X | 0 | (off) |

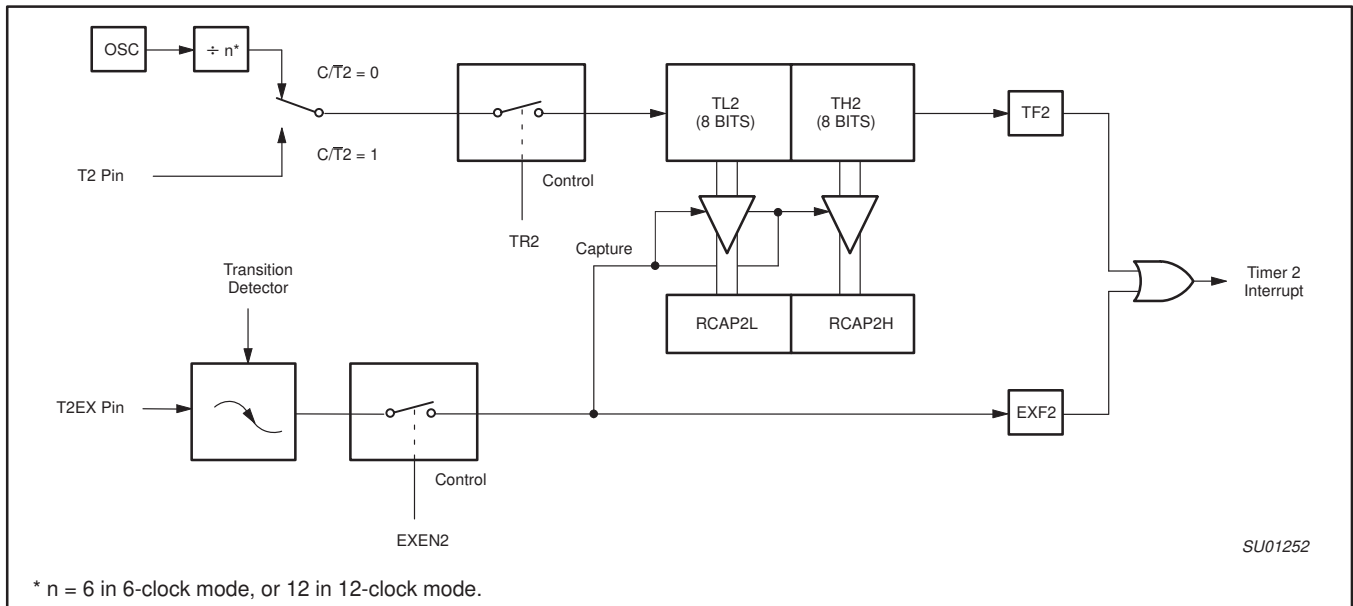

Figure 2. Timer 2 in Capture Mode

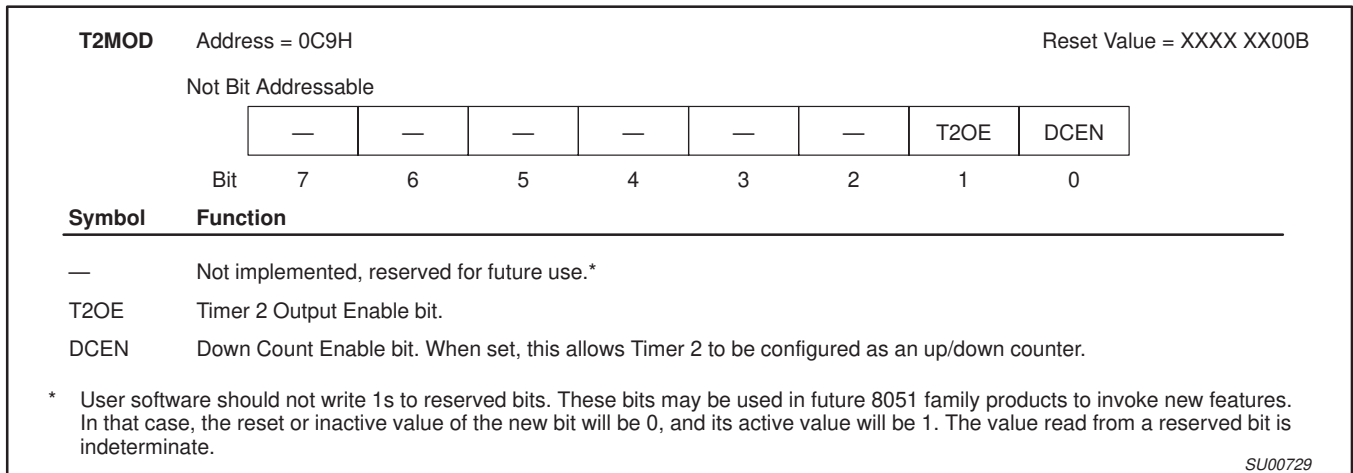

Figure 3. Timer 2 Mode (T2MOD) Control Register

80C51 8-bit microcontroller family 8KB/16KB/32KB/64KB OTP
 with 512B/1KB RAM, low voltage (2.7 to 5.5 V), low power, high
 speed (30/33 MHz)

P87C51RA2/RB2/RC2/RD2

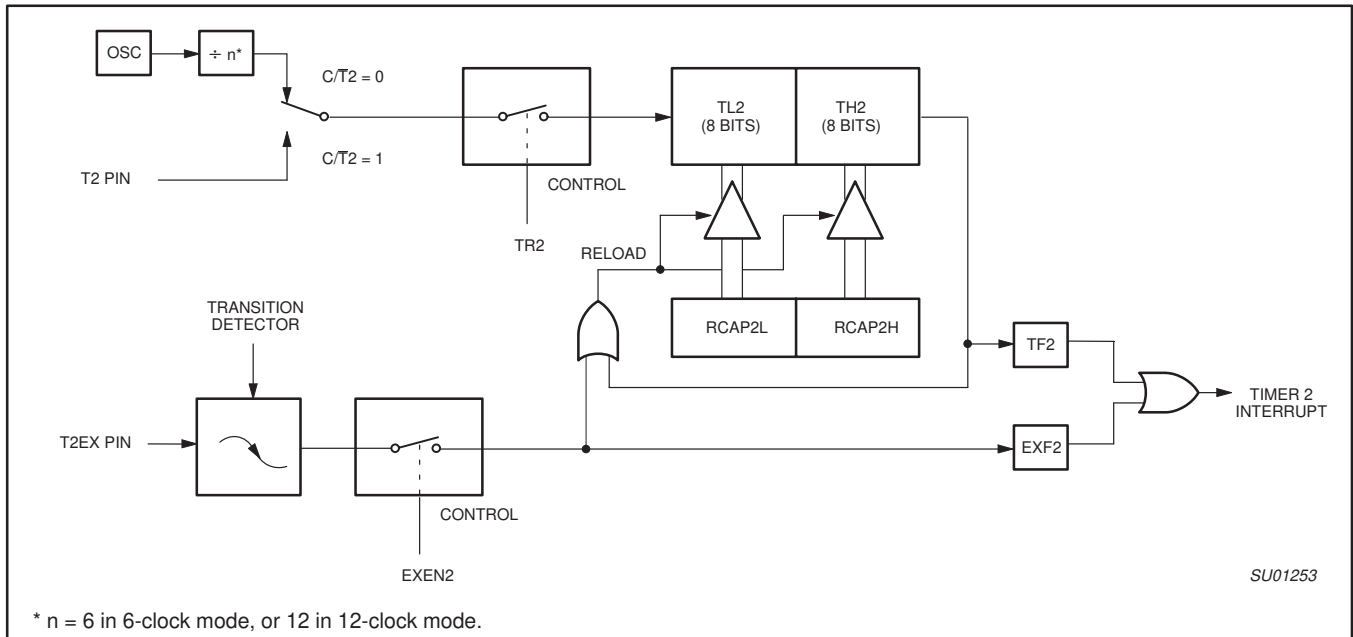

Figure 4. Timer 2 in Auto-Reload Mode (DCEN = 0)

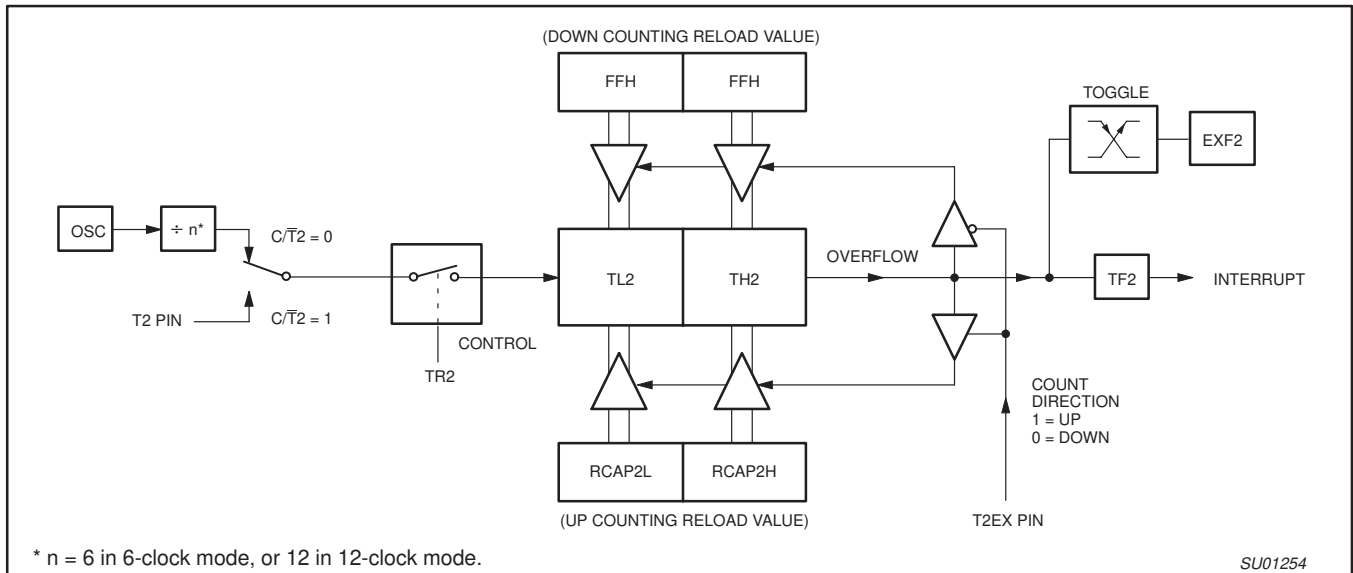

Figure 5. Timer 2 Auto Reload Mode (DCEN = 1)

80C51 8-bit microcontroller family 8KB/16KB/32KB/64KB OTP with 512B/1KB RAM, low voltage (2.7 to 5.5 V), low power, high speed (30/33 MHz)

P87C51RA2/RB2/RC2/RD2

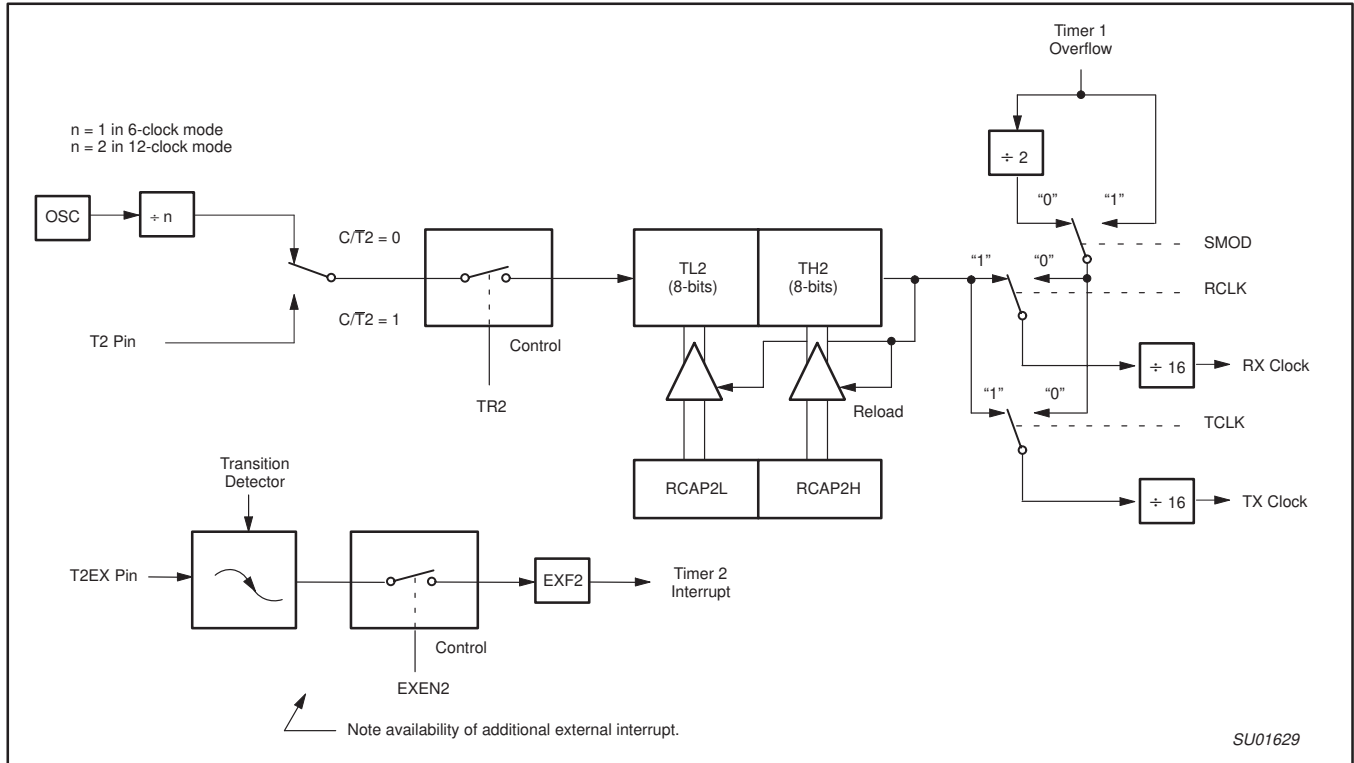

Figure 6. Timer 2 in Baud Rate Generator Mode

Table 4. Timer 2 Generated Commonly Used Baud Rates

| Baud Rate | | Osc Freq | Timer 2 | |
|---------------|--------------|----------|---------|--------|
| 12-clock mode | 6-clock mode | | RCAP2H | RCAP2L |
| 375 k | 750 k | 12 MHz | FF | FF |
| 9.6 k | 19.2 k | 12 MHz | FF | D9 |
| 4.8 k | 9.6 k | 12 MHz | FF | B2 |
| 2.4 k | 4.8 k | 12 MHz | FF | 64 |
| 1.2 k | 2.4 k | 12 MHz | FE | C8 |
| 300 | 600 | 12 MHz | FB | 1E |
| 110 | 220 | 12 MHz | F2 | AF |
| 300 | 600 | 6 MHz | FD | 8F |
| 110 | 220 | 6 MHz | F9 | 57 |

Baud Rate Generator Mode

Bits TCLK and/or RCLK in T2CON (Table 4) allow the serial port transmit and receive baud rates to be derived from either Timer 1 or Timer 2. When TCLK= 0, Timer 1 is used as the serial port transmit baud rate generator. When TCLK= 1, Timer 2 is used as the serial port transmit baud rate generator. RCLK has the same effect for the serial port receive baud rate. With these two bits, the serial port can have different receive and transmit baud rates – one generated by Timer 1, the other by Timer 2.

Figure 6 shows the Timer 2 in baud rate generation mode. The baud rate generation mode is like the auto-reload mode, in that a rollover in TH2 causes the Timer 2 registers to be reloaded with the 16-bit value in registers RCAP2H and RCAP2L, which are preset by software.

The baud rates in modes 1 and 3 are determined by Timer 2's overflow rate given below:

$$\text{Modes 1 and 3 Baud Rates} = \frac{\text{Timer 2 Overflow Rate}}{16}$$

The timer can be configured for either "timer" or "counter" operation. In many applications, it is configured for "timer" operation (C/T2=0). Timer operation is different for Timer 2 when it is being used as a baud rate generator.

Usually, as a timer it would increment every machine cycle (i.e., 1/6 the oscillator frequency in 6-clock mode, 1/12 the oscillator frequency in 12-clock mode). As a baud rate generator, it increments at the oscillator frequency in 6-clock mode (OSC/2 in 12-clock mode). Thus the baud rate formula is as follows:

$$\text{Modes 1 and 3 Baud Rates} = \frac{\text{Oscillator Frequency}}{[n * \times [65536 - (\text{RCAP2H}, \text{RCAP2L})]}$$

* n = 16 in 6-clock mode
32 in 12-clock mode

Where: (RCAP2H, RCAP2L)= The content of RCAP2H and RCAP2L taken as a 16-bit unsigned integer.

The Timer 2 as a baud rate generator mode shown in Figure 6, is valid only if RCLK and/or TCLK = 1 in T2CON register. Note that a rollover in TH2 does not set TF2, and will not generate an interrupt. Thus, the Timer 2 interrupt does not have to be disabled when Timer 2 is in the baud rate generator mode. Also if the EXEN2 (T2 external enable flag) is set, a 1-to-0 transition in T2EX (Timer/counter 2 trigger input) will set EXF2 (T2 external flag) but will not cause a reload from (RCAP2H, RCAP2L) to (TH2, TL2). Therefore when Timer 2 is in use as a baud rate generator, T2EX can be used as an additional external interrupt, if needed.

80C51 8-bit microcontroller family 8KB/16KB/32KB/64KB OTP with 512B/1KB RAM, low voltage (2.7 to 5.5 V), low power, high speed (30/33 MHz)

P87C51RA2/RB2/RC2/RD2

When Timer 2 is in the baud rate generator mode, one should not try to read or write TH2 and TL2. As a baud rate generator, Timer 2 is incremented every state time ($f_{osc}/2$) or asynchronously from pin T2; under these conditions, a read or write of TH2 or TL2 may not be accurate. The RCAP2 registers may be read, but should not be written to, because a write might overlap a reload and cause write and/or reload errors. The timer should be turned off (clear TR2) before accessing the Timer 2 or RCAP2 registers.

Table 4 shows commonly used baud rates and how they can be obtained from Timer 2.

Summary of Baud Rate Equations

Timer 2 is in baud rate generating mode. If Timer 2 is being clocked through pin T2 (P1.0) the baud rate is:

$$\text{Baud Rate} = \frac{\text{Timer 2 Overflow Rate}}{16}$$

If Timer 2 is being clocked internally, the baud rate is:

$$\text{Baud Rate} = \frac{f_{osc}}{[n * \{65536 - (RCAP2H, RCAP2L)\}]}$$

* n = 16 in 6-clock mode
32 in 12-clock mode

Where f_{OSC} = Oscillator Frequency

To obtain the reload value for RCAP2H and RCAP2L, the above equation can be rewritten as:

$$RCAP2H, RCAP2L = 65536 - \left(\frac{f_{osc}}{n * \text{Baud Rate}} \right)$$

Timer/Counter 2 Set-up

Except for the baud rate generator mode, the values given for T2CON do not include the setting of the TR2 bit. Therefore, bit TR2 must be set, separately, to turn the timer on. see Table 5 for set-up of Timer 2 as a timer. Also see Table 6 for set-up of Timer 2 as a counter.

Table 5. Timer 2 as a Timer

| MODE | T2CON | |
|---|---------------------------|---------------------------|
| | INTERNAL CONTROL (Note 1) | EXTERNAL CONTROL (Note 2) |
| 16-bit Auto-Reload | 00H | 08H |
| 16-bit Capture | 01H | 09H |
| Baud rate generator receive and transmit same baud rate | 34H | 36H |
| Receive only | 24H | 26H |
| Transmit only | 14H | 16H |

Table 6. Timer 2 as a Counter

| MODE | TMOD | |
|-------------|---------------------------|---------------------------|
| | INTERNAL CONTROL (Note 1) | EXTERNAL CONTROL (Note 2) |
| 16-bit | 02H | 0AH |
| Auto-Reload | 03H | 0BH |

NOTES:

1. Capture/reload occurs only on timer/counter overflow.
2. Capture/reload occurs on timer/counter overflow and a 1-to-0 transition on T2EX (P1.1) pin except when Timer 2 is used in the baud rate generator mode.

80C51 8-bit microcontroller family 8KB/16KB/32KB/64KB OTP with 512B/1KB RAM, low voltage (2.7 to 5.5 V), low power, high speed (30/33 MHz)

P87C51RA2/RB2/RC2/RD2

FULL-DUPLEX ENHANCED UART

Standard UART operation

The serial port is full duplex, meaning it can transmit and receive simultaneously. It is also receive-buffered, meaning it can commence reception of a second byte before a previously received byte has been read from the register. (However, if the first byte still hasn't been read by the time reception of the second byte is complete, one of the bytes will be lost.) The serial port receive and transmit registers are both accessed at Special Function Register SBUF. Writing to SBUF loads the transmit register, and reading SBUF accesses a physically separate receive register.

The serial port can operate in 4 modes:

- Mode 0:** Serial data enters and exits through RxD. TxD outputs the shift clock. 8 bits are transmitted/received (LSB first). The baud rate is fixed at 1/12 the oscillator frequency in 12-clock mode or 1/6 the oscillator frequency in 6-clock mode.
- Mode 1:** 10 bits are transmitted (through TxD) or received (through RxD): a start bit (0), 8 data bits (LSB first), and a stop bit (1). On receive, the stop bit goes into RB8 in Special Function Register SCON. The baud rate is variable.
- Mode 2:** 11 bits are transmitted (through TxD) or received (through RxD): start bit (0), 8 data bits (LSB first), a programmable 9th data bit, and a stop bit (1). On Transmit, the 9th data bit (TB8 in SCON) can be assigned the value of 0 or 1. Or, for example, the parity bit (P, in the PSW) could be moved into TB8. On receive, the 9th data bit goes into RB8 in Special Function Register SCON, while the stop bit is ignored. The baud rate is programmable to either 1/32 or 1/64 the oscillator frequency in 12-clock mode or 1/16 or 1/32 the oscillator frequency in 6-clock mode.
- Mode 3:** 11 bits are transmitted (through TxD) or received (through RxD): a start bit (0), 8 data bits (LSB first), a programmable 9th data bit, and a stop bit (1). In fact, Mode 3 is the same as Mode 2 in all respects except baud rate. The baud rate in Mode 3 is variable.

In all four modes, transmission is initiated by any instruction that uses SBUF as a destination register. Reception is initiated in Mode 0 by the condition RI = 0 and REN = 1. Reception is initiated in the other modes by the incoming start bit if REN = 1.

Multiprocessor Communications

Modes 2 and 3 have a special provision for multiprocessor communications. In these modes, 9 data bits are received. The 9th one goes into RB8. Then comes a stop bit. The port can be programmed such that when the stop bit is received, the serial port interrupt will be activated only if RB8 = 1. This feature is enabled by setting bit SM2 in SCON. A way to use this feature in multiprocessor systems is as follows:

When the master processor wants to transmit a block of data to one of several slaves, it first sends out an address byte which identifies the target slave. An address byte differs from a data byte in that the 9th bit is 1 in an address byte and 0 in a data byte. With SM2 = 1, no slave will be interrupted by a data byte. An address byte, however, will interrupt all slaves, so that each slave can examine the received byte and see if it is being addressed. The addressed slave will clear its SM2 bit and prepare to receive the data bytes that will be coming.

The slaves that weren't being addressed leave their SM2s set and go on about their business, ignoring the coming data bytes.

SM2 has no effect in Mode 0, and in Mode 1 can be used to check the validity of the stop bit. In a Mode 1 reception, if SM2 = 1, the receive interrupt will not be activated unless a valid stop bit is received.

Serial Port Control Register

The serial port control and status register is the Special Function Register SCON, shown in Figure 7. This register contains not only the mode selection bits, but also the 9th data bit for transmit and receive (TB8 and RB8), and the serial port interrupt bits (TI and RI).

Baud Rates

The baud rate in Mode 0 is fixed: Mode 0 Baud Rate = Oscillator Frequency / 12 (12-clock mode) or / 6 (6-clock mode). The baud rate in Mode 2 depends on the value of bit SMOD in Special Function Register PCON. If SMOD = 0 (which is the value on reset), and the port pins in 12-clock mode, the baud rate is 1/64 the oscillator frequency. If SMOD = 1, the baud rate is 1/32 the oscillator frequency. In 6-clock mode, the baud rate is 1/32 or 1/16 the oscillator frequency, respectively.

Mode 2 Baud Rate =

$$\frac{2^{SMOD}}{n} \times (\text{Oscillator Frequency})$$

Where:

$$n = 64 \text{ in 12-clock mode, } 32 \text{ in 6-clock mode}$$

The baud rates in Modes 1 and 3 are determined by the Timer 1 or Timer 2 overflow rate.

Using Timer 1 to Generate Baud Rates

When Timer 1 is used as the baud rate generator (T2CON.RCLK = 0, T2CON.TCLK = 0), the baud rates in Modes 1 and 3 are determined by the Timer 1 overflow rate and the value of SMOD as follows:

Mode 1, 3 Baud Rate =

$$\frac{2^{SMOD}}{n} \times (\text{Timer 1 Overflow Rate})$$

Where:

$$n = 32 \text{ in 12-clock mode, } 16 \text{ in 6-clock mode}$$

The Timer 1 interrupt should be disabled in this application. The Timer itself can be configured for either "timer" or "counter" operation, and in any of its 3 running modes. In the most typical applications, it is configured for "timer" operation, in the auto-reload mode (high nibble of TMOD = 0010B). In that case the baud rate is given by the formula:

Mode 1, 3 Baud Rate =

$$\frac{2^{SMOD}}{n} \times \frac{\text{Oscillator Frequency}}{12 \times [256 - (TH1)]}$$

Where:

$$n = 32 \text{ in 12-clock mode, } 16 \text{ in 6-clock mode}$$

One can achieve very low baud rates with Timer 1 by leaving the Timer 1 interrupt enabled, and configuring the Timer to run as a 16-bit timer (high nibble of TMOD = 0001B), and using the Timer 1 interrupt to do a 16-bit software reload. Figure 8 lists various commonly used baud rates and how they can be obtained from Timer 1.

80C51 8-bit microcontroller family 8KB/16KB/32KB/64KB OTP with 512B/1KB RAM, low voltage (2.7 to 5.5 V), low power, high speed (30/33 MHz)

P87C51RA2/RB2/RC2/RD2

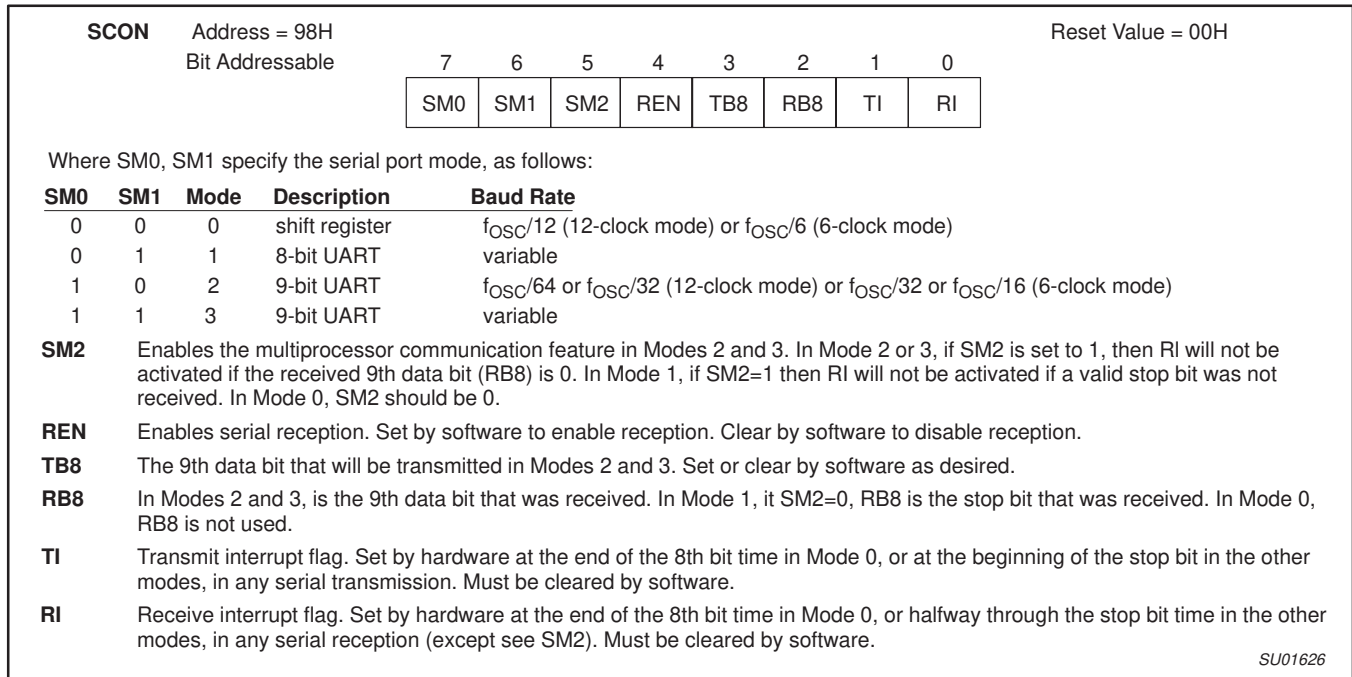

Figure 7. Serial Port Control (SCON) Register

| Baud Rate | | | f _{osc} | SMOD | Timer 1 | | |
|---------------|---------------|--------------|------------------|------|---------|------|--------------|
| Mode | 12-clock mode | 6-clock mode | | | C/T | Mode | Reload Value |
| Mode 0 Max | 1.67 MHz | 3.34 MHz | 20 MHz | X | X | X | X |
| Mode 2 Max | 625 k | 1250 k | 20 MHz | 1 | X | X | X |
| Mode 1, 3 Max | 104.2 k | 208.4 k | 20 MHz | 1 | 0 | 2 | FFH |
| Mode 1, 3 | 19.2 k | 38.4 k | 11.059 MHz | 1 | 0 | 2 | FDH |
| | 9.6 k | 19.2 k | 11.059 MHz | 0 | 0 | 2 | FDH |
| | 4.8 k | 9.6 k | 11.059 MHz | 0 | 0 | 2 | FAH |
| | 2.4 k | 4.8 k | 11.059 MHz | 0 | 0 | 2 | F4H |
| | 1.2 k | 2.4 k | 11.059 MHz | 0 | 0 | 2 | E8H |
| | 137.5 | 275 | 11.986 MHz | 0 | 0 | 2 | 1DH |
| | 110 | 220 | 6 MHz | 0 | 0 | 2 | 72H |
| | 110 | 220 | 12 MHz | 0 | 0 | 1 | FEEBH |

Figure 8. Timer 1 Generated Commonly Used Baud Rates

More About Mode 0

Serial data enters and exits through RxD. TxD outputs the shift clock. 8 bits are transmitted/received: 8 data bits (LSB first). The baud rate is fixed a 1/12 the oscillator frequency (12-clock mode) or 1/6 the oscillator frequency (6-clock mode).

Figure 9 shows a simplified functional diagram of the serial port in Mode 0, and associated timing.

Transmission is initiated by any instruction that uses SBUF as a destination register. The "write to SBUF" signal at S6P2 also loads a 1 into the 9th position of the transmit shift register and tells the TX Control block to commence a transmission. The internal timing is such that one full machine cycle will elapse between "write to SBUF" and activation of SEND.

SEND enables the output of the shift register to the alternate output function line of P3.0 and also enable SHIFT CLOCK to the alternate output function line of P3.1. SHIFT CLOCK is low during S3, S4, and S5 of every machine cycle, and high during S6, S1, and S2. At

S6P2 of every machine cycle in which SEND is active, the contents of the transmit shift are shifted to the right one position.

As data bits shift out to the right, zeros come in from the left. When the MSB of the data byte is at the output position of the shift register, then the 1 that was initially loaded into the 9th position, is just to the left of the MSB, and all positions to the left of that contain zeros. This condition flags the TX Control block to do one last shift and then deactivate SEND and set T1. Both of these actions occur at S1P1 of the 10th machine cycle after "write to SBUF."

Reception is initiated by the condition REN = 1 and R1 = 0. At S6P2 of the next machine cycle, the RX Control unit writes the bits 11111110 to the receive shift register, and in the next clock phase activates RECEIVE.

RECEIVE enable SHIFT CLOCK to the alternate output function line of P3.1. SHIFT CLOCK makes transitions at S3P1 and S6P1 of every machine cycle. At S6P2 of every machine cycle in which RECEIVE is active, the contents of the receive shift register are

80C51 8-bit microcontroller family 8KB/16KB/32KB/64KB OTP with 512B/1KB RAM, low voltage (2.7 to 5.5 V), low power, high speed (30/33 MHz)

P87C51RA2/RB2/RC2/RD2

shifted to the left one position. The value that comes in from the right is the value that was sampled at the P3.0 pin at S5P2 of the same machine cycle.

As data bits come in from the right, 1s shift out to the left. When the 0 that was initially loaded into the rightmost position arrives at the leftmost position in the shift register, it flags the RX Control block to do one last shift and load SBUF. At S1P1 of the 10th machine cycle after the write to SCON that cleared RI, RECEIVE is cleared as RI is set.

More About Mode 1

Ten bits are transmitted (through TxD), or received (through RxD): a start bit (0), 8 data bits (LSB first), and a stop bit (1). On receive, the stop bit goes into RB8 in SCON. In the 80C51 the baud rate is determined by the Timer 1 or Timer 2 overflow rate.

Figure 10 shows a simplified functional diagram of the serial port in Mode 1, and associated timings for transmit receive.

Transmission is initiated by any instruction that uses SBUF as a destination register. The "write to SBUF" signal also loads a 1 into the 9th bit position of the transmit shift register and flags the TX Control unit that a transmission is requested. Transmission actually commences at S1P1 of the machine cycle following the next rollover in the divide-by-16 counter. (Thus, the bit times are synchronized to the divide-by-16 counter, not to the "write to SBUF" signal.)

The transmission begins with activation of SEND which puts the start bit at TxD. One bit time later, DATA is activated, which enables the output bit of the transmit shift register to TxD. The first shift pulse occurs one bit time after that.

As data bits shift out to the right, zeros are clocked in from the left. When the MSB of the data byte is at the output position of the shift register, then the 1 that was initially loaded into the 9th position is just to the left of the MSB, and all positions to the left of that contain zeros. This condition flags the TX Control unit to do one last shift and then deactivate SEND and set TI. This occurs at the 10th divide-by-16 rollover after "write to SBUF."

Reception is initiated by a detected 1-to-0 transition at RxD. For this purpose RxD is sampled at a rate of 16 times whatever baud rate has been established. When a transition is detected, the divide-by-16 counter is immediately reset, and 1FFH is written into the input shift register. Resetting the divide-by-16 counter aligns its rollovers with the boundaries of the incoming bit times.

The 16 states of the counter divide each bit time into 16ths. At the 7th, 8th, and 9th counter states of each bit time, the bit detector samples the value of RxD. The value accepted is the value that was seen in at least 2 of the 3 samples. This is done for noise rejection. If the value accepted during the first bit time is not 0, the receive circuits are reset and the unit goes back to looking for another 1-to-0 transition. This is to provide rejection of false start bits. If the start bit proves valid, it is shifted into the input shift register, and reception of the rest of the frame will proceed.

As data bits come in from the right, 1s shift out to the left. When the start bit arrives at the leftmost position in the shift register (which in mode 1 is a 9-bit register), it flags the RX Control block to do one last shift, load SBUF and RB8, and set RI. The signal to load SBUF and RB8, and to set RI, will be generated if, and only if, the following conditions are met at the time the final shift pulse is generated.:

1. RI = 0, and
2. Either SM2 = 0, or the received stop bit = 1.

If either of these two conditions is not met, the received frame is irretrievably lost. If both conditions are met, the stop bit goes into RB8, the 8 data bits go into SBUF, and RI is activated. At this time,

whether the above conditions are met or not, the unit goes back to looking for a 1-to-0 transition in RxD.

More About Modes 2 and 3

Eleven bits are transmitted (through TxD), or received (through RxD): a start bit (0), 8 data bits (LSB first), a programmable 9th data bit, and a stop bit (1). On transmit, the 9th data bit (TB8) can be assigned the value of 0 or 1. On receive, the 9th data bit goes into RB8 in SCON. The baud rate is programmable to either 1/32 or 1/64 (12-clock mode) or 1/16 or 1/32 the oscillator frequency (6-clock mode) the oscillator frequency in Mode 2. Mode 3 may have a variable baud rate generated from Timer 1 or Timer 2.

Figures 11 and 12 show a functional diagram of the serial port in Modes 2 and 3. The receive portion is exactly the same as in Mode 1. The transmit portion differs from Mode 1 only in the 9th bit of the transmit shift register.

Transmission is initiated by any instruction that uses SBUF as a destination register. The "write to SBUF" signal also loads TB8 into the 9th bit position of the transmit shift register and flags the TX Control unit that a transmission is requested. Transmission commences at S1P1 of the machine cycle following the next rollover in the divide-by-16 counter. (Thus, the bit times are synchronized to the divide-by-16 counter, not to the "write to SBUF" signal.)

The transmission begins with activation of SEND, which puts the start bit at TxD. One bit time later, DATA is activated, which enables the output bit of the transmit shift register to TxD. The first shift pulse occurs one bit time after that. The first shift clocks a 1 (the stop bit) into the 9th bit position of the shift register. Thereafter, only zeros are clocked in. Thus, as data bits shift out to the right, zeros are clocked in from the left. When TB8 is at the output position of the shift register, then the stop bit is just to the left of TB8, and all positions to the left of that contain zeros. This condition flags the TX Control unit to do one last shift and then deactivate SEND and set TI. This occurs at the 11th divide-by-16 rollover after "write to SBUF."

Reception is initiated by a detected 1-to-0 transition at RxD. For this purpose RxD is sampled at a rate of 16 times whatever baud rate has been established. When a transition is detected, the divide-by-16 counter is immediately reset, and 1FFH is written to the input shift register.

At the 7th, 8th, and 9th counter states of each bit time, the bit detector samples the value of R-D. The value accepted is the value that was seen in at least 2 of the 3 samples. If the value accepted during the first bit time is not 0, the receive circuits are reset and the unit goes back to looking for another 1-to-0 transition. If the start bit proves valid, it is shifted into the input shift register, and reception of the rest of the frame will proceed.

As data bits come in from the right, 1s shift out to the left. When the start bit arrives at the leftmost position in the shift register (which in Modes 2 and 3 is a 9-bit register), it flags the RX Control block to do one last shift, load SBUF and RB8, and set RI.

The signal to load SBUF and RB8, and to set RI, will be generated if, and only if, the following conditions are met at the time the final shift pulse is generated.

1. RI = 0, and
2. Either SM2 = 0, or the received 9th data bit = 1.

If either of these conditions is not met, the received frame is irretrievably lost, and RI is not set. If both conditions are met, the received 9th data bit goes into RB8, and the first 8 data bits go into SBUF. One bit time later, whether the above conditions were met or not, the unit goes back to looking for a 1-to-0 transition at the RxD input.

80C51 8-bit microcontroller family 8KB/16KB/32KB/64KB OTP with 512B/1KB RAM, low voltage (2.7 to 5.5 V), low power, high speed (30/33 MHz)

P87C51RA2/RB2/RC2/RD2

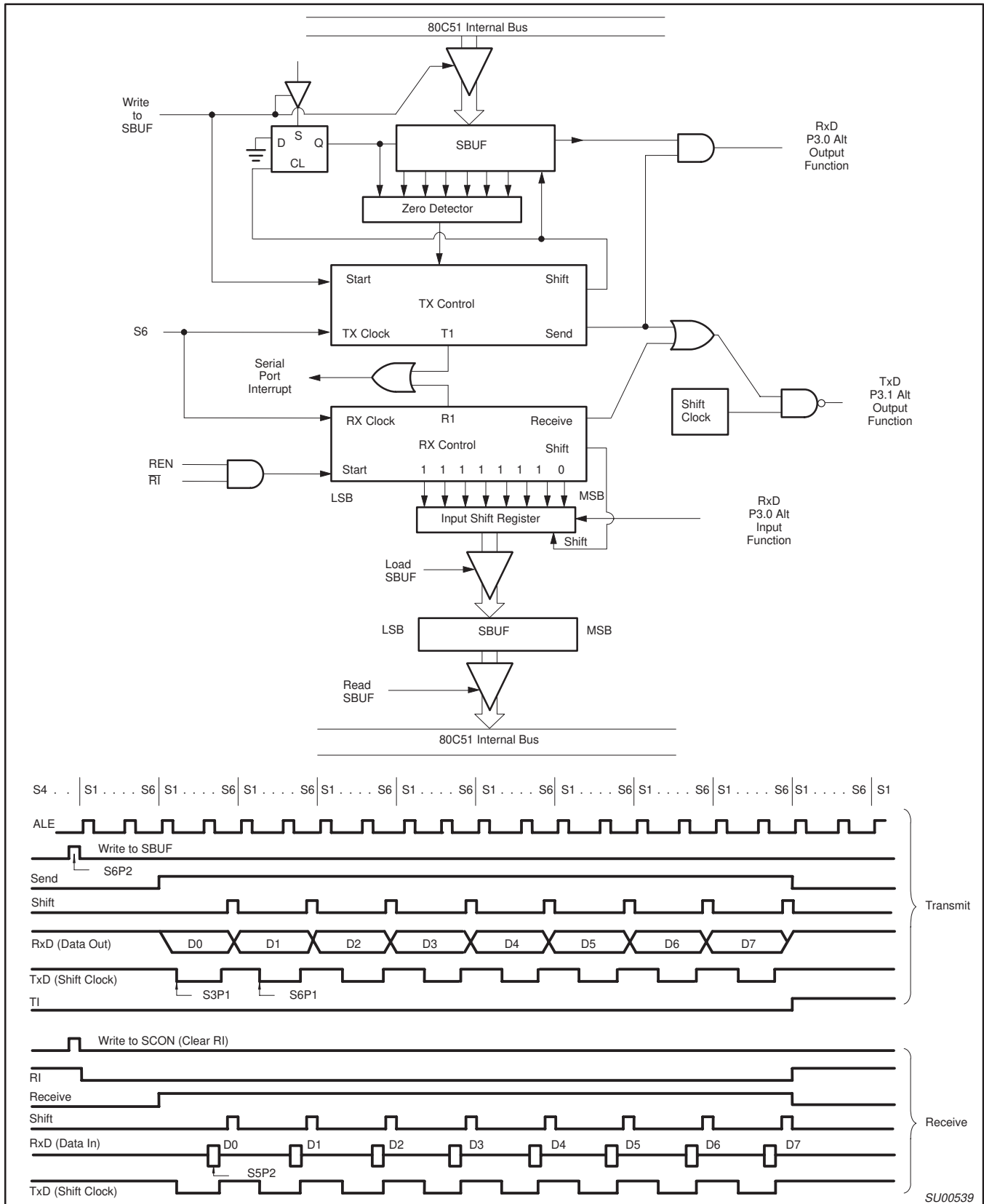
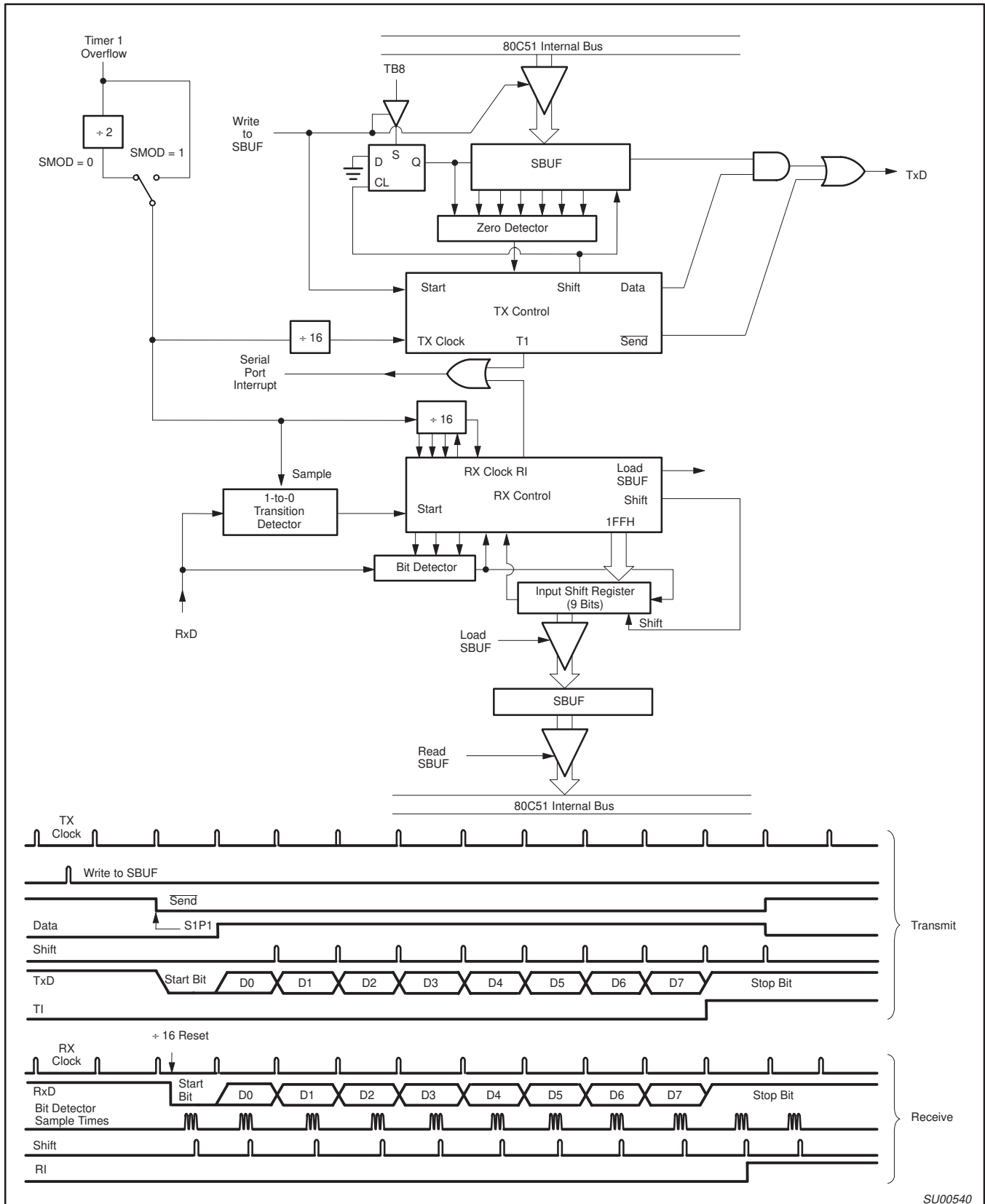

Figure 9. Serial Port Mode 0

SU00539

80C51 8-bit microcontroller family 8KB/16KB/32KB/64KB OTP
 with 512B/1KB RAM, low voltage (2.7 to 5.5 V), low power, high
 speed (30/33 MHz)

P87C51RA2/RB2/RC2/RD2



SU00540

Figure 10. Serial Port Mode 1