



Chipsmall Limited consists of a professional team with an average of over 10 year of expertise in the distribution of electronic components. Based in Hongkong, we have already established firm and mutual-benefit business relationships with customers from,Europe,America and south Asia,supplying obsolete and hard-to-find components to meet their specific needs.

With the principle of "Quality Parts,Customers Priority,Honest Operation,and Considerate Service",our business mainly focus on the distribution of electronic components. Line cards we deal with include Microchip,ALPS,ROHM,Xilinx,Pulse,ON,Everlight and Freescale. Main products comprise IC,Modules,Potentiometer,IC Socket,Relay,Connector.Our parts cover such applications as commercial,industrial, and automotives areas.

We are looking forward to setting up business relationship with you and hope to provide you with the best service and solution. Let us make a better world for our industry!



Contact us

Tel: +86-755-8981 8866 Fax: +86-755-8427 6832

Email & Skype: info@chipsmall.com Web: www.chipsmall.com

Address: A1208, Overseas Decoration Building, #122 Zhenhua RD., Futian, Shenzhen, China



Features

- Dual-Mode Wireless Power Receiver
Complies with WPC 1.0.1 and PMA Type 1 Requirements for Certification
- Single-Chip Solution
- Compatible with all WPC receiver coils including proprietary and PCB-based coils
- Integrated Synchronous Full-Bridge Rectifier
- Integrated Synchronous Buck Converter
- Closed-Loop Power Transfer control between Base Station and Mobile Device
- Optional Proprietary Back-Channel Communication
- Security and Encryption up to 64-bit
- Power Good Status Pin
- I²C Interface
- WLCSP package, 4.65mm x 4.86mm, 0.4mm pitch

Safety Features

- Optional, Advanced Multi-layered Foreign Object Detection (FOD)
- Over Temperature/Voltage/Current Protection
- User-programmable GPIOs for a variety of LED status/alarm and buzzer indicators
- Thermal loop control

Applications

- Smartphones, Handsets, and related Accessories
- Bluetooth devices
- Game Controllers, Remote Controls
- PC Peripherals and Storage devices
- Tools, medical monitors, fitness accessories

Description

The IDTP9021 is a Dual-Mode single-chip Wireless Power Receiver IC which complies with the requirements of both WPC 1.0.1 and PMA Type 1 Interoperability specifications. The device receives an AC power signal from a compatible wireless transmitter and converts it into a regulated 5V output voltage which can be used to power devices or supply the charger input in mobile applications.

The IDTP9021 integrates a high-efficiency synchronous full-bridge rectifier, high-efficiency synchronous buck converter, and control circuits used to modulate the load to transmit WPC or PMA-compliant message packets to the transmitter to optimize power delivery. In WPC mode, power delivery is limited to 5W in accordance with the Qi specification. All communication and protocol selection can be managed by the device, without user supervision. The device also features optional communication security with data encryption using a Secure Hash Algorithm (SHA) of up to 64 bits when communicating with other IDT Wireless Power devices.

The device includes over-temperature and over-voltage protection and a Foreign Object Detection method to protect the base station and the mobile device from overheating in the presence of a metallic foreign object. Fault conditions associated with power transfer are managed by the embedded MCU, which also controls Status LEDs to indicate operating and fault modes. The IDTP9021 is available in a 4.86mm x 4.65mm WLCSP package.

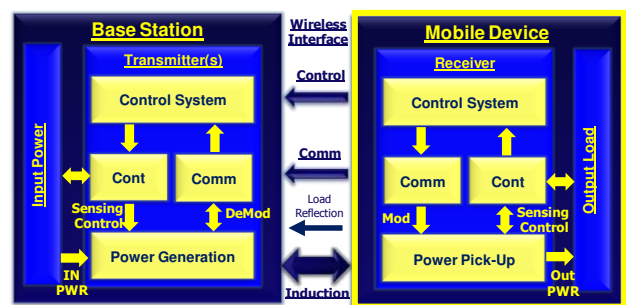

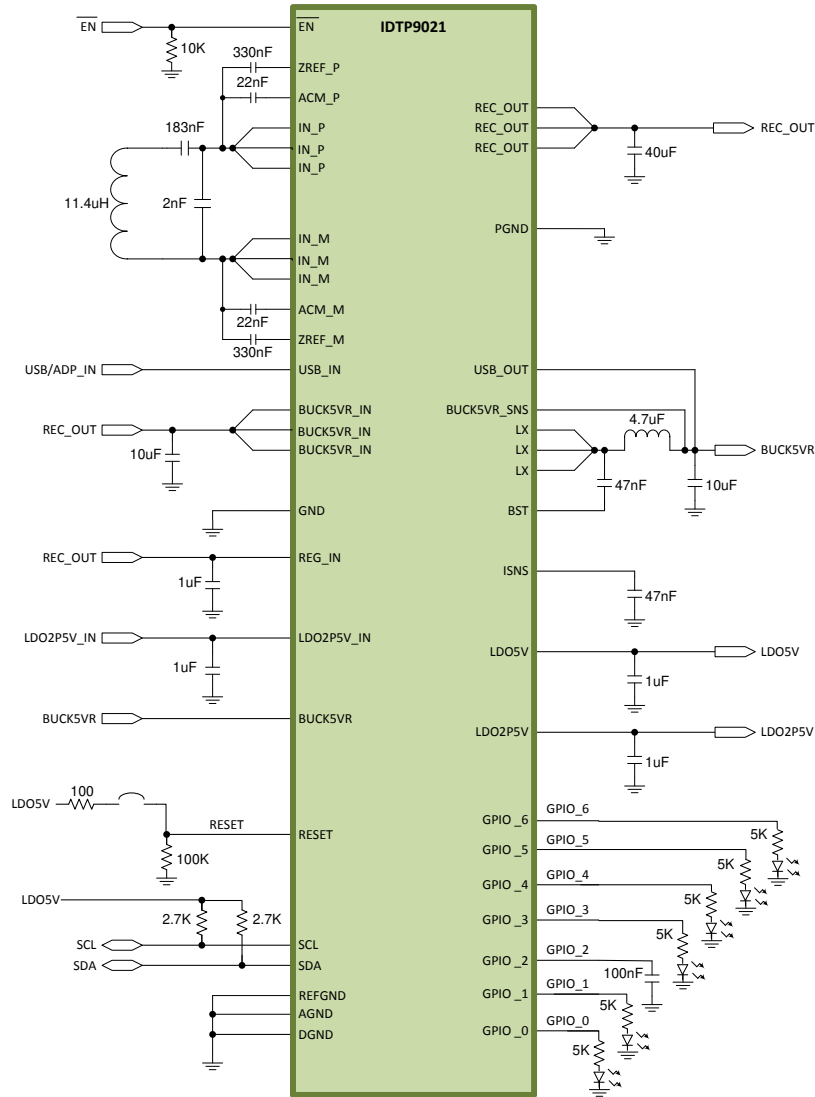

Fig. 2 IDTP9021 Typical Application Circuit

Preliminary Information – Subject to Change



**6024 Silver Creek Valley Road
San Jose, California 95138**

Tel: 800-345-7015

DISCLAIMER Integrated Device Technology, Inc. (IDT) and its subsidiaries reserve the right to modify the products and/or specifications described herein at any time and at IDT's sole discretion. All information in this document, including descriptions of product features and performance, is subject to change without notice. Performance specifications and the operating parameters of the described products are determined in the independent state and are not guaranteed to perform the same way when installed in customer products. The information contained herein is provided without representation or warranty of any kind, whether express or implied, including, but not limited to, the suitability of IDT's products for any particular purpose, an implied warranty of merchantability, or non-infringement of the intellectual property rights of others. This document is presented only as a guide and does not convey any license under intellectual property rights of IDT or any third parties. IDT's products are not intended for use in life support systems or similar devices where the failure or malfunction of an IDT product can be reasonably expected to significantly affect the health or safety of users. Anyone using an IDT product in such a manner does so at their own risk, absent an express, written agreement by IDT.

Integrated Device Technology, IDT and the IDT logo are registered trademarks of IDT. Other trademarks and service marks used herein, including protected names, logos and designs, are the property of IDT or their respective third party owners.

© Copyright 2013. All rights reserved.