



Chipsmall Limited consists of a professional team with an average of over 10 year of expertise in the distribution of electronic components. Based in Hongkong, we have already established firm and mutual-benefit business relationships with customers from,Europe,America and south Asia,supplying obsolete and hard-to-find components to meet their specific needs.

With the principle of “Quality Parts,Customers Priority,Honest Operation,and Considerate Service”,our business mainly focus on the distribution of electronic components. Line cards we deal with include Microchip,ALPS,ROHM,Xilinx,Pulse,ON,Everlight and Freescale. Main products comprise IC,Modules,Potentiometer,IC Socket,Relay,Connector.Our parts cover such applications as commercial,industrial, and automotives areas.

We are looking forward to setting up business relationship with you and hope to provide you with the best service and solution. Let us make a better world for our industry!



Contact us

Tel: +86-755-8981 8866 Fax: +86-755-8427 6832

Email & Skype: info@chipsmall.com Web: www.chipsmall.com

Address: A1208, Overseas Decoration Building, #122 Zhenhua RD., Futian, Shenzhen, China



Features & Benefits

- WPC 1.1.2 (Qi) compliant for interoperability Compact form factor for fast prototyping
- Layout module provided for direct copy to system board
- 2-layer PCB reference layout and fully-tested BOM
- 4.5 to 6.9 V input, designed for 5 W output on the receiver
- Integrated power stage for low BOM cost, low manufacturing cost, and small PCB area
- Input in-rush control prevents surges with inexpensive power adapters

Evaluation Kit Contents

- One fully-assembled P9038-R-EVK reference board
- USB to Micro USB cable
- Application notes, datasheets, manuals, guides, videos, layout files, and other digital resources can be found at: idt.com/P9038-R-EVK

Description

The P9038-R-EVK is a turnkey 5 Watt, Qi-compliant wireless power transmitter reference kit for fast prototyping and design integration. The kit consists of an easy-to-use reference board and comprehensive support collateral that significantly eases design-in effort and minimizes time-to-market.

An associated layout module enables direct instantiation on to a system board, while an optimized and fully-tested Bill-of-Materials (BOM) takes the guess-work out of component selection. The P9038-based solution is well-suited for a wide range of applications, including PC peripherals, furniture, medical devices, and other portable devices still hindered by traditional contact-based charging bases or cables.

The board features a ubiquitous micro-USB connector to supply 5 V power to the input. Alternatively, VIN and GND test points can be connected to a different power source or wired directly into a prototype system.

IDT's wireless power transmitter solution is complemented by the P9025AC-R-EVK Qi-compliant 5 Watt wireless power receiver reference kit. Visit idt.com/P9025AC-R-EVK to learn more.

Figure 1. Reference Board Illustration

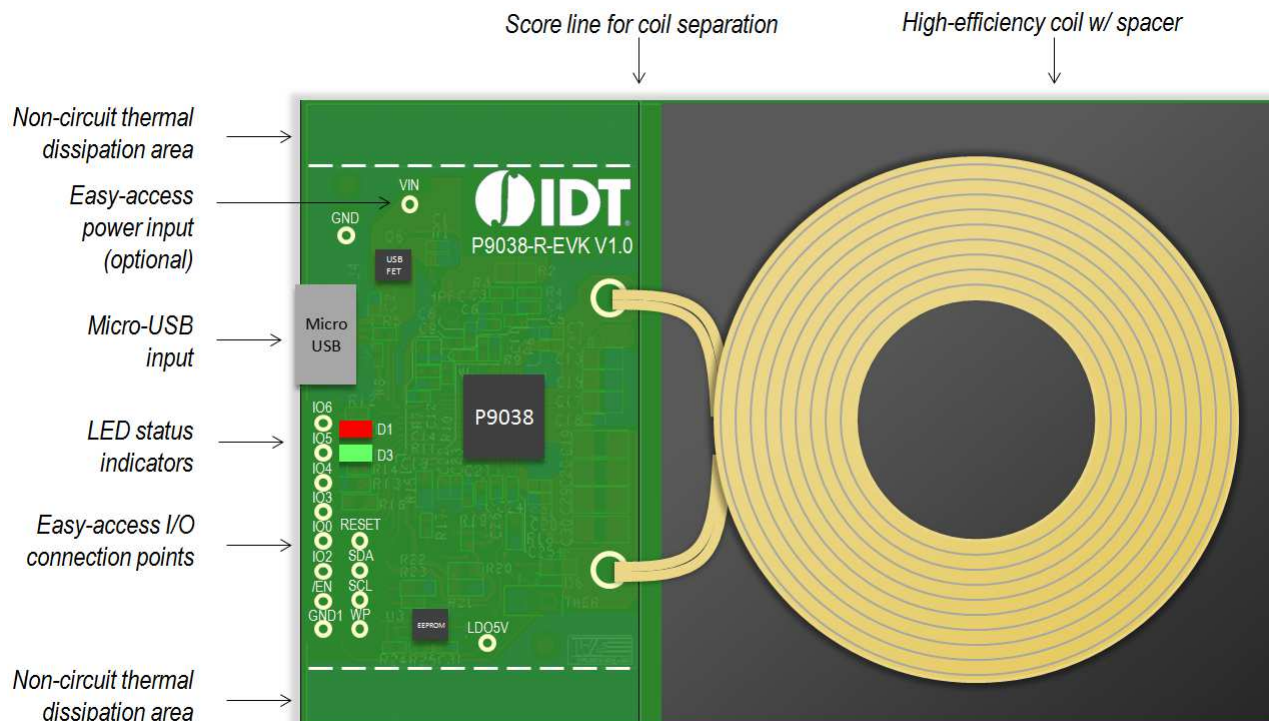

Usage Guide

This reference board is designed to demonstrate the performance and functionality of the P9038 as a fully-functional Qi-compliant wireless power transmitter pad. In most cases, this board can be wired into an existing system for evaluation and prototyping.

Quick Start Guide

Follow these simple steps to power-up and begin using the P9038-R-EVK board:

1. Connect a 5 Volt, 2 Amp micro-USB charger to the board

Note: lower-power sources can be used, but will limit the maximum power transfer.

2. Place a Qi-compatible receiver on top of the plastic coil spacer
3. Verify that the green LED is blinking – coupling has been established

Input Power Supply

The P9038-R-EVK features a micro-USB input connector as the primary power source. This connector was selected because micro-USB adapters are commonly available in most offices and labs. If preferred, an alternative 5 V power supply can be wired directly into the VIN and GND test points.

An optional MOSFET (Q6) is connected in series with the micro-USB connector (J4). While the MOSFET is not required for operating the P9038 from a USB adapter, it is required for strict USB compliance, serving to limit inrush current and provide over-voltage protection for anything over 12 V DC. IDT recommends using the MOSFET if the board might draw power from a standard USB port, such as from a USB connector on a laptop or PC. If the application will not be powered by a standard USB port, and the input voltage can be controlled not to exceed 12 V DC, then the series MOSFET can be removed.

EEPROM Configuration

The EEPROM on the P9038-R-EVK board is programmed with a standard configuration optimized for the reference layout and coil. This configuration is automatically loaded into the P9038 device registers when power is applied.

Flexibility to tailor the device behavior to a specific application can be accomplished by using external resistors to select the LED mode and FOD offset. Details about the default configuration and selectable modes and offsets can be found in the P9038 product datasheet.

Qi Compliance & Certification

The P9038-R-EVK reference board is designed to be compliant to the WPC 1.1.5 Qi specification, but it is not Qi-certified. This distinction is important because a Qi-certified product has completed a strict interoperability testing protocol in its final form factor. That means, the product containing this board or using the reference layout and bill-of-materials should be certified separately.

With that said, the P9038-R-EVK provides all of the necessary features and flexibility needed to attain Qi-certification. By using the provided reference design, a system prototype can be created with minimal changes, and thus, minimal engineering risk.

To learn more about attaining Qi-certification, visit:

<http://www.wirelesspowerconsortium.com/developers/product-testing-and-registration.html>

LED Status Indicators

The P9038-R-EVK is equipped with two LED status indicators: green and red. A red LED indicates various Fault and FOD ("Foreign Object Detection") states. The green LED indicates Power Transfer and Charge Complete state information. Upon power up, the two LEDs together may optionally indicate the Standby State and remain in this state until another of the defined Operational States occurs.

The P9038 offers several LED control options that are configurable by the external resistor network on the GPIO3 pin. The stock P9038-R-EVK reference board has a pull down (R21) to GND, and therefore, is pre-configured to LED Control Option 1. The status indicators behave as follows:

	Green LED	Red LED
Standby	On	On
Transfer	Blink 1 Hz	Off
Complete	One	Off
CS100	Blink 0.5 Hz	Off
Power	Blink 2 Hz	Off
Fault	Off	Blink 4 Hz

To learn more about different LED control options, refer to the P9038 product datasheet. If desired, the brightness of the LEDs can be increased by lowering the value of resistors R12 and R14.

Test Point Accessibility

The P9038-R-EVK reference board was designed so that the core layout could be easily copied to an existing system board design. For this reason, all of the necessary inputs and outputs are placed toward the edge of the board to eliminate uncertainty in escape routing. For more information about copying the digital layout files, refer to application note [AN-894 P9038 Layout Guidelines](#).

When prototyping using the direct VIN and GND vias instead of the micro-USB input, it is important to use a low-resistance wire that is rated for the expected input current. This will avoid damage to the wire and minimize voltage drops on its way to the input.

Plastic Coil Spacer

A good wireless power transfer system should maintain a small separation gap between the transmitter coil and the receiver coil. The Qi specification requires a separation gap of 1.75 to 2.5 mm on the transmitter. For the reference board, a plastic square has been glued to the top of the coil to mimic the separation typically achieved by the final product casing. Although the coil itself is protected by non-conductive encapsulation, it is recommended to use the plastic spacer to archive optimal power transfer efficiency.

For prototyping, it may be useful to remove the plastic spacer. This is easily done by simply prying it off with your fingers. The coil ferrite is also glued to the board, so it's a good idea to push down on the ferrite while you slowly lift off the plastic. To see a video demonstration, visit: [idt.com/P9038-R-EVK](#)

Separating the Coil from the Board

The P9038-R-EVK reference board has been precisely tuned for the stock coil attached to the PCB. The PCB material that extends under the coil ferrite is for physical stability only. The board has been designed with a score line enabling users to snap-off of the PCB section on which the coil ferrite is glued. This can be done by carefully placing the board on the edge of a table and applying downward pressure on the coil.

It is also possible to remove the PCB from the bottom of the ferrite. This is easily done by prying the two components apart. While doing this, take care not to damage the coil leads. In some cases, especially when planning to extend the coil leads, it's best to unsolder the coil leads from the PCB prior to snapping or separating the PCB. In addition, any wires used to extend the leads of the coil should be twisted to help cancel the inductance of the new wire.

To see a video demonstration of separating the coil mount or removing the coil from the board, visit: [idt.com/P9038-R-EVK](#)

Minimizing the Physical PCB Area

When space is limited, the P9038-R-EVK board can be made smaller in two ways. First, the coil can be separated from the board as explained in the section titled "Separating the Coil from the Board". Second, there are two areas on the edge of the component area that can be sawed off. There is no active circuitry in these areas. To see a video demonstration, visit: [idt.com/P9038-R-EVK](#)

Physical Specifications

The following specifications are based on the Gerber files:

- Width: 53.5 mm
- Component area length (from edge to score line): 28.8 mm
- Total board length (from edge to edge): 84.4 mm
- PCB thickness: 0.80 mm

The following specifications were measured by hand on one board sample using the Würth Elektronik coil 760308111. These values are for estimation purposes only. Actual specifications may vary.

- Thickness of active circuit (components and solder, not including coil): ~ 4 mm
- Total thickness (including coil, plastic spacer, and rubber feet): ~ 10 mm
- Total weight (including plastic spacer and rubber feet): ~ 68 grams

Note that the thickness of the solution can be minimized when the rubber feet, coil mount, and plastic spacer have been removed so that the coil ferrite is sitting next to the active circuit area. In that case, the total thickness of the solution is dependent on the thickness of the coil or components.

Board Schematic

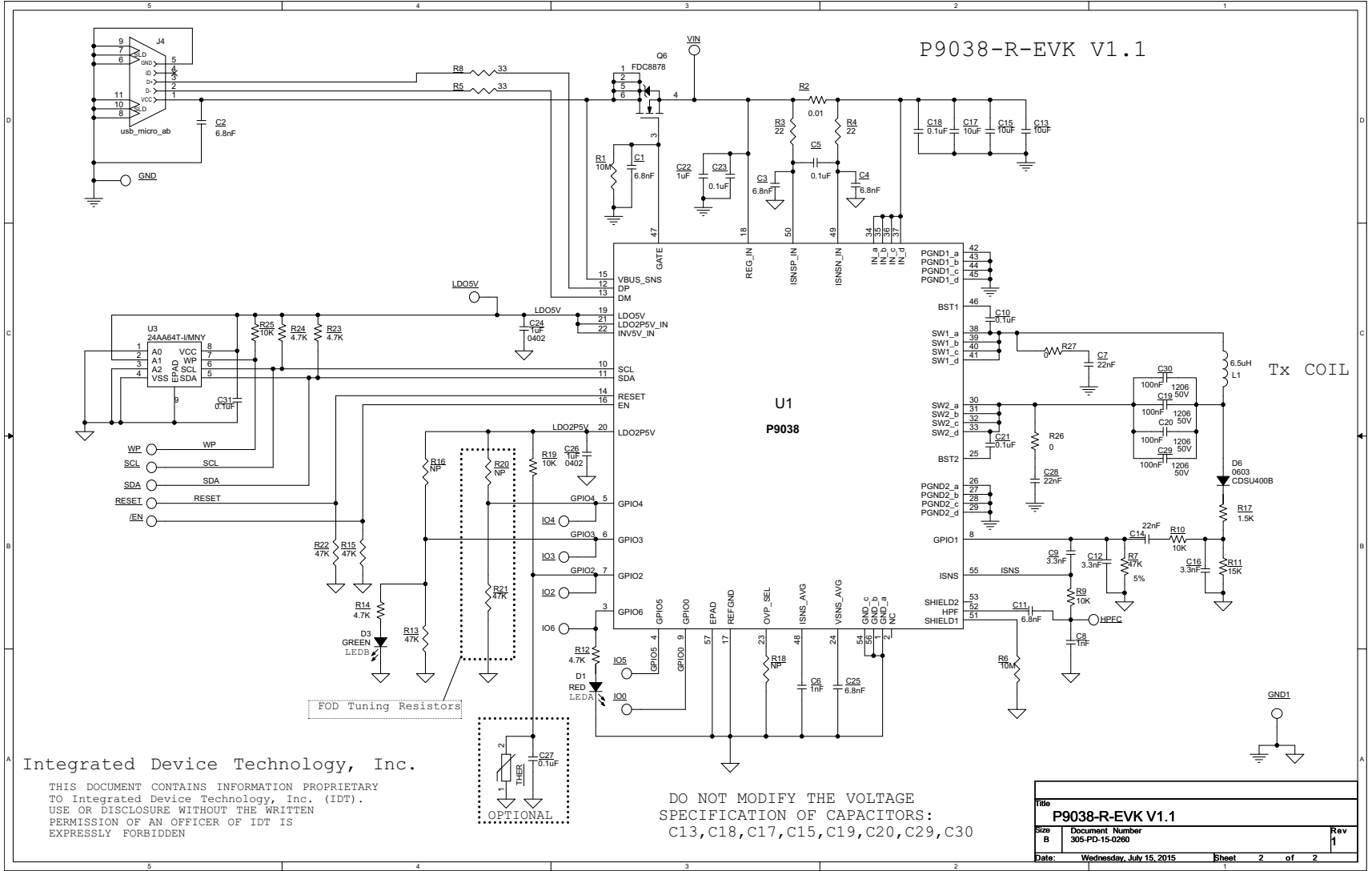

Component Map

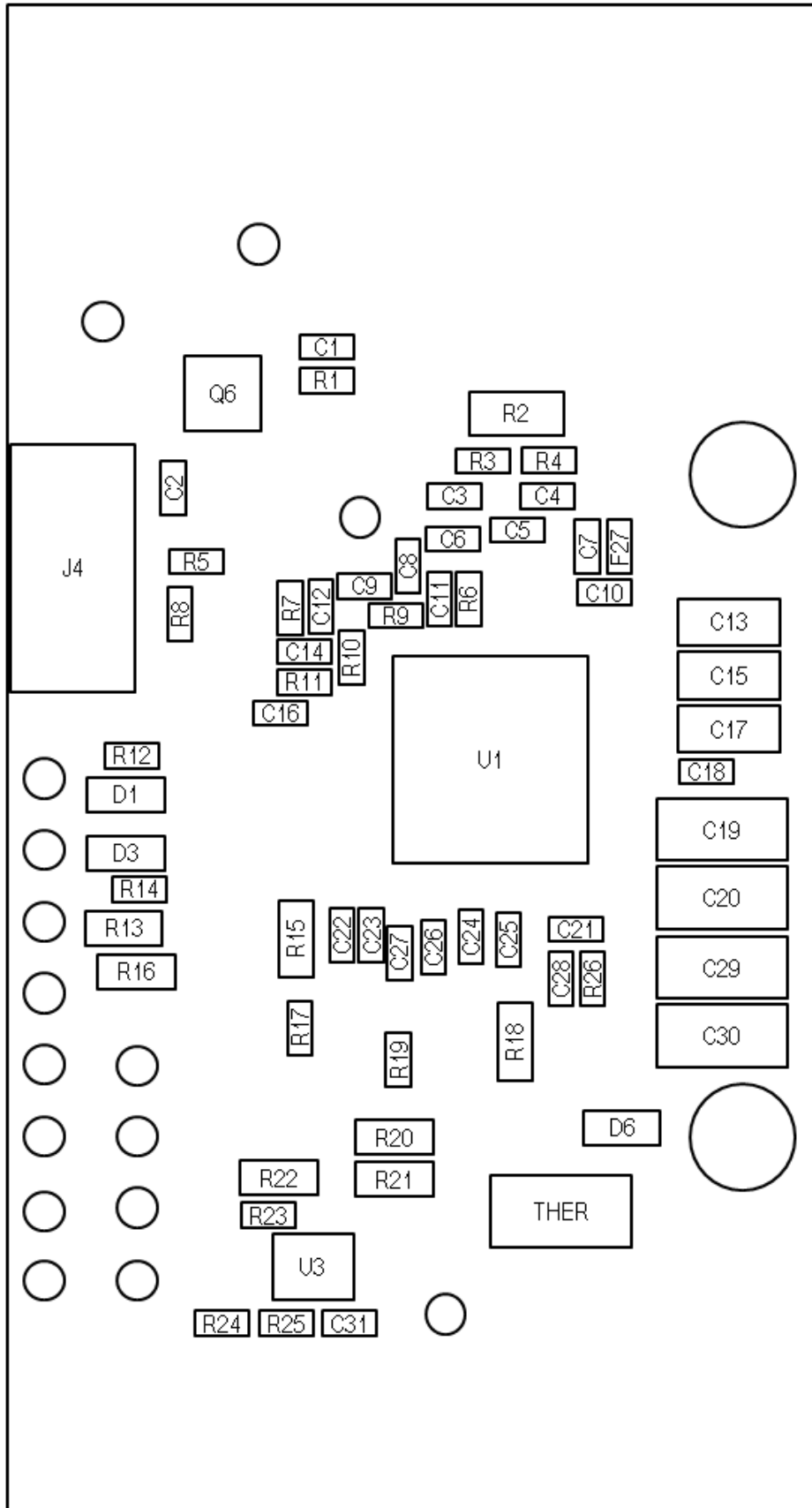

Symbol	Value	Purpose	Part Number
C1	6.8nF	Delay setting capacitor for soft-on	GRM155R71E682KA01D
C2	6.8nF	USB connector high frequency bypass	GRM155R71E682KA01D
C3	6.8nF	High frequency bypass for current sensing input	GRM155R71E682KA01D
C4	6.8nF	High frequency bypass for current sensing input	GRM155R71E682KA01D
C5	0.1 μ F	Low pass filter for current sensing input	GRM155R71C104KA88D
C6	1nF	Low pass filter for current sensing output	GRM155R71C102KA01D
C7	22nF	Slew rate limiting capacitor for SW2 switching node	CL05B223KA5NNNC
C8	1nF	Demodulation third-stage low pass filter	GRM155R71C102KA01D
C9	3.3nF	Low pass filter for ISNS output	C0402C332K3RACTU
C10	0.1 μ F	Boost capacitor for switching node driver stage	GRM155R71C104KA88D
C11	6.8nF	High-Pass filter for HPF input	GRM155R71E682KA01D
C12	3.3nF	Demodulation second-stage low pass filter	C0402C332K3RACTU
C13	10 μ F	DC input bulk capacitor	GRM21BR61C106KE15L
C14	22nF	DC blocking for demodulation peak detector	GRM155R71H223KA12J
C15	10 μ F	DC input bulk capacitor	GRM21BR61C106KE15L
C16	3.3nF	Demodulation peak detector first-stage low pass filter	C1005X7R1H332K050BA
C17	10 μ F	DC input bulk capacitor	GRM21BR61C106KE15L
C18	0.1 μ F	DC input bypass capacitor	GRM155R71C104KA88D
C19	100nF	Series-resonant LC tank capacitor	C3216C0G1H104J160AA
C20	100nF	Series-resonant LC tank capacitor	C3216C0G1H104J160AA
C21	0.1 μ F	Boost capacitor for switching node driver stage	GRM155R71C104KA88D
C22	1 μ F	5Vdc Voltage regulator input bypass	C1005X5R1C105K050BC
C23	0.1 μ F	5Vdc Voltage regulator input bypass	GRM155R71C104KA88D
C24	1 μ F	5Vdc voltage regulator output bulk capacitor	C1005X5R1C105K050BC
C25	6.8nF	DC input voltage measurement filter capacitor	GRM155R71E682KA01D
C26	1 μ F	2.5Vdc voltage regulator output bulk capacitor	C1005X5R1C105K050BC
C27	0.1 μ F	Low pass filter for optional thermistor circuit	CL05A104MP5NNNC
C28	22nF	Slew rate limiting capacitor for SW2 switching node	CL05B223KA5NNNC
C29	100nF	Series-resonant LC tank capacitor	C3216C0G1H104J160AA
C30	100nF	Series-resonant LC tank capacitor	C3216C0G1H104J160AA
C31	0.1 μ F	Bypass capacitor for EEPROM device	CL05A104MP5NNNC
D1	RED	Red user interface indicating LED	150060SS75000
D3	GREEN	Green user interface indicating LED	150060VS75000
D6	CDSU400B		CDSU400B
/EN	30AWG		-
GND	30AWG		-
GND1	30AWG		-
HPFC	30AWG		-
IO0	30AWG		-
IO2	30AWG		-
IO3	30AWG		-
IO4	30AWG		-

Symbol	Value	Purpose	Part Number
IO5	30AWG		–
IO6	30AWG		–
J4	5P		629105150921
L1	6.5uH	Primary coil for LC tank	760308111
LDO5V	30AWG		–
Q6	FDC8878	Inrush current limiting transistor	FDC8878
R1	10M	Guaranteed turn-off leakage for inrush current limiter	RC1005F106CS
R2	0.01	Current sensing resistor	ERJ-6BWFR010V
R3	22	Low-pass filter for current sensing input	RC0402JR-0722RL
R4	22	Low-pass filter for current sensing input	RC0402JR-0722RL
R5	33	Current limiting resistor for DM input pin	RC1005J330CS
R6	10 MΩ	Leakage path for SHIELD1 pin	RC1005F106CS
R7	47 kΩ	Demodulation second-stage low pass filter	ERJ-2GEJ473X
R8	33	Current limiting resistor for DP input pin	RC1005J330CS
R9	10 kΩ	Demodulation third-stage low pass filter	RC0402FR-0710KL
R10	10 kΩ	First stage demodulation high-pass filter	CRCW040210K0JNED
R11	15 kΩ	Demodulation peak detector leakage resistor	ERJ-2RKF1502X
R12	4.7 kΩ	Current limiting resistor for Red LED	ERJ-2GEJ472X
R13	47 kΩ	Low-side resistor for LED mode setting	ERJ-3GEYJ473V
R14	4.7 kΩ	Current limiting resistor for Green LED	ERJ-2GEJ472X
R15	47 kΩ	Pull-down for Enable pin	ERJ-3GEYJ473V
R16	NP	High-side resistor for LED mode setting	–
R17	1.5 kΩ	Demodulation peak detector first stage low-pass filter	ERJ-2RKF1501X
R18	NP	Overvoltage shutoff limit option setting resistor	–
R19	10 kΩ	Precision pull-up for thermistor circuit option	CRCW040210K0JNED
R20	NP	High-side resistor for FOD adjustment option	–
R21	47 kΩ	Low-side resistor for FOD adjustment option	ERJ-3GEYJ473V
R22	47 kΩ	Pull-down for Reset pin	ERJ-3GEYJ473V
R23	4.7 kΩ	Pull-up for SDA pin	ERJ-2GEJ472X
R24	4.7 kΩ	Pull-up for SCL pin	ERJ-2GEJ472X
R25	10 kΩ	Pull-up for EEPROM Write-Pulse pin	CRCW040210K0JNED
R26	0.0 Ω		ERJ-2GE0R00X
R27	0.0 Ω		ERJ-2GE0R00X
RESET	30AWG		–
SCL	30AWG		–
SDA	30AWG		–
THER	NP	Optional thermistor for temperature sensing circuit	B57551G0103f000
U1	P9038	Single-chip wireless power device	P9038-RNDGI
U3	24AA64T-I/MNY	EEPROM for firmware program storage	24AA64T-I/MNY
VIN	30AWG		–
WP	30AWG		–

A detailed bill-of-materials (BOM) spreadsheet can be found at www.idt.com/P9038-R-EVK

Top Layer

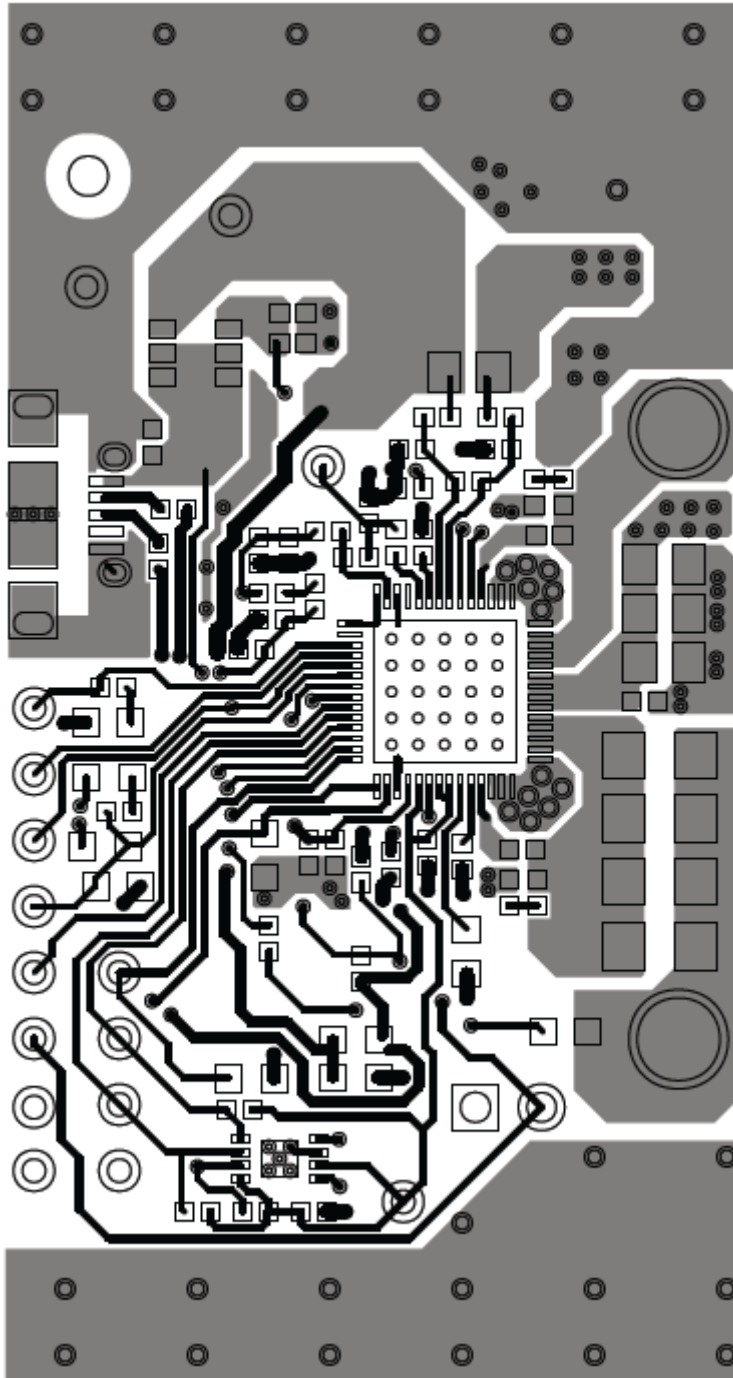

Bottom Layer

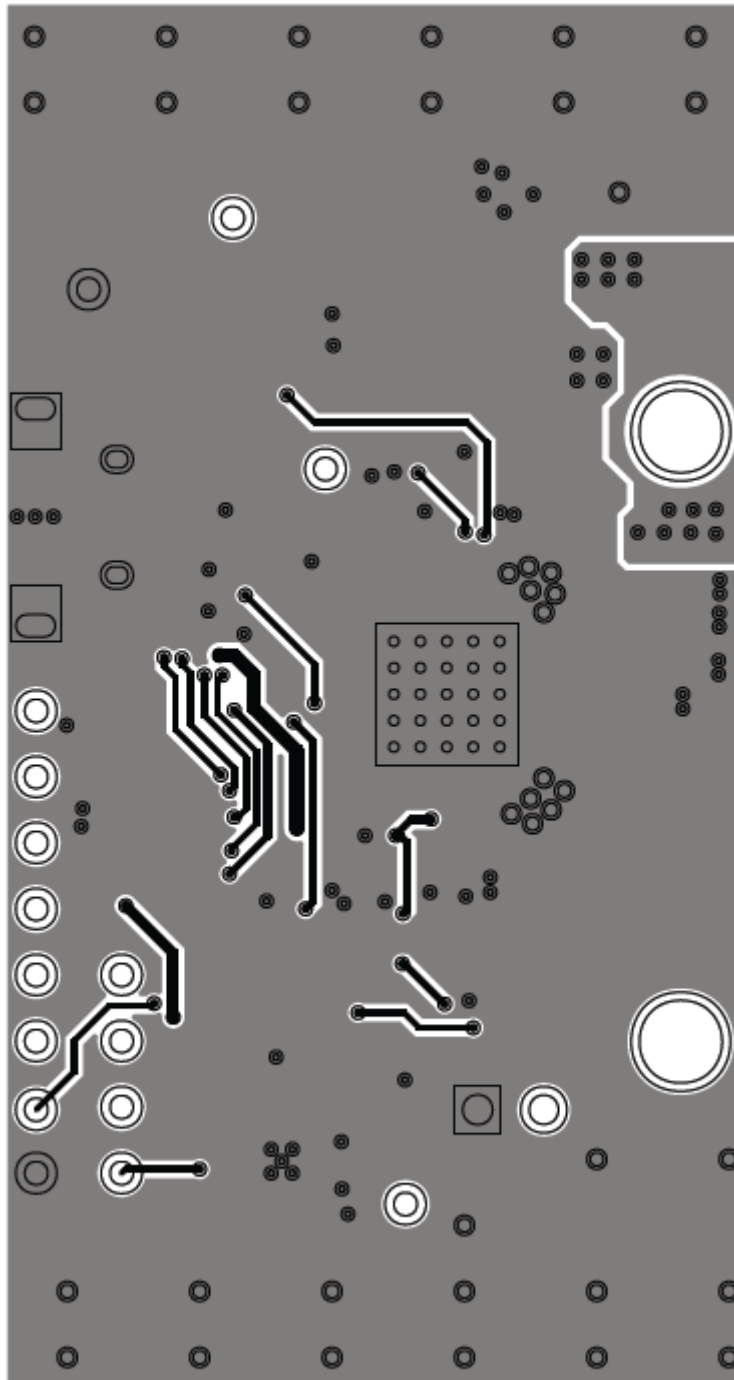



Corporate Headquarters
6024 Silver Creek Valley Road
San Jose, CA 95138 USA

Sales
1-800-345-7015 or 408-284-8200
Fax: 408-284-2775
www.IDT.com

Tech Support
www.idt.com/go/support

DISCLAIMER Integrated Device Technology, Inc. (IDT) and its subsidiaries reserve the right to modify the products and/or specifications described herein at any time and at IDT's sole discretion. All information in this document, including descriptions of product features and performance, is subject to change without notice. Performance specifications and the operating parameters of the described products are determined in the independent state and are not guaranteed to perform the same way when installed in customer products. The information contained herein is provided without representation or warranty of any kind, whether express or implied, including, but not limited to, the suitability of IDT's products for any particular purpose, an implied warranty of merchantability, or non-infringement of the intellectual property rights of others. This document is presented only as a guide and does not convey any license under intellectual property rights of IDT or any third parties.

IDT's products are not intended for use in applications involving extreme environmental conditions or in life support systems or similar devices where the failure or malfunction of an IDT product can be reasonably expected to significantly affect the health or safety of users. Anyone using an IDT product in such a manner does so at their own risk, absent an express, written agreement by IDT.

Integrated Device Technology, IDT and the IDT logo are registered trademarks of IDT. Product specification subject to change without notice. Other trademarks and service marks used herein, including protected names, logos and designs, are the property of IDT or their respective third party owners.

Copyright ©2015 Integrated Device Technology, Inc.. All rights reserved.