



Chipsmall Limited consists of a professional team with an average of over 10 year of expertise in the distribution of electronic components. Based in Hongkong, we have already established firm and mutual-benefit business relationships with customers from,Europe,America and south Asia,supplying obsolete and hard-to-find components to meet their specific needs.

With the principle of “Quality Parts,Customers Priority,Honest Operation,and Considerate Service”,our business mainly focus on the distribution of electronic components. Line cards we deal with include Microchip,ALPS,ROHM,Xilinx,Pulse,ON,Everlight and Freescale. Main products comprise IC,Modules,Potentiometer,IC Socket,Relay,Connector.Our parts cover such applications as commercial,industrial, and automotives areas.

We are looking forward to setting up business relationship with you and hope to provide you with the best service and solution. Let us make a better world for our industry!



## Contact us

Tel: +86-755-8981 8866 Fax: +86-755-8427 6832

Email & Skype: info@chipsmall.com Web: www.chipsmall.com

Address: A1208, Overseas Decoration Building, #122 Zhenhua RD., Futian, Shenzhen, China



ENGINEERING SPECIFICATION

10W AC Charger

Part Number: PA-1100-2L

APPROVAL BY: \_\_\_\_\_

Customer	Rev.	Written By	Effective Date	LITE-ON Technology Corp.
	X02	Leon Chang	2012/11/12	SHEET 1 of 10
				LTADPDOC-001-0B1

**Revision History**REV.X01, 2012.11.12

-Initial release.

REV.X02.2013.2.20

-Update Dimension and Weight

**Table Contents**

Customer	Rev.	Written By	Effective Date	LITE-ON Technology Corp.
	X02	Leon Chang	2012/11/12	SHEET 2 of 10
				LTADPDOC-001-0B1

<b>1. General</b> .....	5
1.1. SCOPE.....	5
<b>2. INPUT REQUIREMENTS</b> .....	5
2.1. INPUT VOLTAGE .....	5
2.2. FREQUENCY .....	5
2.3. Voltage Section.....	5
2.4. Efficiency & Energy Star Requirement .....	5
2.5. Input Current.....	5
2.6. Inrush Current .....	5
2.7. POWER SUPPLY EFFICIENCY .....	5
<b>3. OUTPUT REQUIREMENTS</b> .....	6
3.1. STATIC DC LOAD .....	6
3.2. DYNAMIC LOAD .....	6
3.3. TURN ON DELAY TIME .....	6
3.4. RISE TIME.....	6
3.5. RIPPLE AND NOISE .....	6
3.6. LOAD IMPEDANCE.....	6
3.7. HOLD UP TIME.....	6
<b>4. NO LOAD OPERATION</b> .....	7
<b>5. PROTECTION</b> .....	7
5.1. OVER VOLTAGE PROTECTION.....	7
5.2. SHORT CIRCUIT PROTECTION .....	7
5.3. OVER CURRENT PROTECTION .....	7
<b>6. SAFETY REQUIREMENTS</b> .....	7
6.1. DIELECTRIC STRENGTH .....	7
6.2. INSULATION RESISTANCE .....	7
6.3. GROUND LEAKAGE CURRENT .....	7
<b>7. ELECTROMAGNETIC COMPATIBILITY</b> .....	7
7.1. FCC REQUIREMENTS.....	7
7.2. VDE REQUIREMENTS.....	8
7.3. VCCI REQUIREMENTS .....	8
7.4. EMC REQUIREMENTS .....	8
7.5. LIGHTNING SURGE .....	8
7.6. ESD.....	8
<b>8. RELIABILITY</b> .....	8
8.1. MTBF.....	8
8.2. OPERATION LIFE.....	8
<b>9. ENVIROMENT</b> .....	8
9.1. OPERATING .....	8
9.2. SHIPPING AND STORAGE .....	9

<b>Customer</b>	<b>Rev.</b>	<b>Written By</b>	<b>Effective Date</b>	<b>LITE-ON Technology Corp.</b>
	X02	Leon Chang	2012/11/12	SHEET 3 of 10
				LTADPDOC-001-0B1

---

9.3. ALTITUDE .....9  
9.4. REGUALTED SUBSTANCE REQUIREMENT .....9  
**10. TEMPERATURE RISE OF CASE SURFACE.....9**  
**11. MACHANICAL .....9**  
11.1. DIMENSION .....9  
11.2. WEIGHT.....10  
11.3. DC CABLE .....10

<b>Customer</b>	<b>Rev.</b>	<b>Written By</b>	<b>Effective Date</b>	<b>LITE-ON Technology Corp.</b>
	X02	<b>Leon Chang</b>	<b>2012/11/12</b>	SHEET 4 of 10
				<b>LTADPDOC-001-0B1</b>

## 1. General

### 1.1. SCOPE

This specification defines the performance characteristics of a grounded single phase, 10 watt, 5Vdc output, ROHS power supply. This specification also defines worldwide safety and electromagnetic compatibility requirements for the power supply which is intended for use in USB device charger.

## 2. INPUT REQUIREMENTS

### 2.1. INPUT VOLTAGE

	MINIMUM	MAXIMUM	NOMINAL
<b>LOW RANGE</b>	90VAC	132VAC	100-120VAC
<b>HIGH RANGE</b>	180VAC	264VAC	200-240VAC

### 2.2. FREQUENCY

	MINIMUM	MAXIMUM	NOMINAL
<b>SINGLE PHASE</b>	47Hz	63Hz	50-60Hz

### 2.3. Voltage Section

A full range will be provided to select the appropriate range.

### 2.4. Efficiency & Energy Star Requirement

The Adaptor shall be designed to meet EPS Requirement as below for both 115VAC and 230VAC:

- a. No Load Average Power Loss shall be less than **100mW** at 230Vac/50Hz.
- b. Efficiency shall higher than **75%** at the USB connector-end at input voltage 110Vac/60Hz and 230Vac/50Hz with a 2A load condition.
- c. Average Efficiency value of 25%, 50%, 75%, 100% load condition shall higher **76%** at the USB connector-end at input voltage 110Vac/60Hz and 230Vac/50Hz.

### 2.5. Input Current

**0.4** Amps maximum at nominal input voltage within the low range as specified in paragraph 2.1 and at any combination of loading conditions.

### 2.6. Inrush Current

Peak inrush current: Inrush current shall not exceed 85% of the max rated value including I<sup>2</sup>t derating for all input components.

### 2.7. POWER SUPPLY EFFICIENCY

The power supply efficiency shall meet requirement as specified in item 2.4 with the AC input set at the nominal voltage.

Customer	Rev.	Written By	Effective Date	LITE-ON Technology Corp.
	X02	Leon Chang	2012/11/12	SHEET 5 of 10
				LTADPDOC-001-0B1



### 3. OUTPUT REQUIREMENTS

#### 3.1. STATIC DC LOAD

NOMINAL VOLTAGE (V)	LOAD CURRENT(A)		REGULATION
	MIN.	MAX.	
+5	0	2	+4.6V~+5.4V

#### 3.2. DYNAMIC LOAD

NOMINAL VOLTAGE (V)	LOAD CURRENT(A)		REGULATION
	MIN.	MAX.	
+5	0.1	1	+4.4V~+6V
	1	2	

#### 3.3. TURN ON DELAY TIME

The output turn on delay time (time from the application of AC to output within regulation limits) shall be less than **2s**.

#### 3.4. RISE TIME

The output rise time (measured from the 10% point to the 90% point on the waveform) shall be less than **50ms**.

#### 3.5. RIPPLE AND NOISE

The ripple and noise of the outputs shall be measured at the load end if the output cables when terminated to load impedance as specified in paragraph 3.1

OUTPUT VOLTAGE		RIPPLE & NOISE (P-P)	
+5	V	200	mV

1. Use 20MHz Bandwidth frequency scope.
2. Output added 0.1uF ceramic capacitor and 10uF tantalum capacitor capacitors.

#### 3.6. LOAD IMPEDANCE

Filter capacitors are connected to each pins of the mating output connector. Capacitance values and material type are listed below.

VOLTAGE NOM.(V)	CAPACITANCE NOM. (uF)	MATERIAL TYPE
+5V	0.1uF/10uF	CERAMIC/TAN

#### 3.7. HOLD UP TIME

The power supply shall maintain voltage regulation within the specified limits in paragraph 3.1 for at least **3** milliseconds after lost of input voltage measure at 100 Vac(rms) and at maximum output load.

Customer	Rev.	Written By	Effective Date	LITE-ON Technology Corp.
	X02	Leon Chang	2012/11/12	SHEET 6 of 10
				LTADPDOC-001-0B1

#### 4. NO LOAD OPERATION

The power supply shall be able to operate under no load condition. No damage to the power supply is allowed and internal component can not be stressed beyond its rating

#### 5. PROTECTION

##### 5.1. OVER VOLTAGE PROTECTION

The power supply should shutdown for any cause of over voltage conditions before any output exceeds its limits below.

NOMINAL OUTPUT VOLTAGE (V)	OVER VOLTAGE
	MAX.
+5V	7V

##### 5.2. SHORT CIRCUIT PROTECTION

A short circuit placed on DC output shall cause no damage and no overheat and latch –off in the power supply. The power supply will be auto-recovery

##### 5.3. OVER CURRENT PROTECTION

The power supply shall provide over current protection on output. Maximum current inception point of output shall be limited to the following values:

OUTPUT VOLTAGE (V)	CURRENT LIMIT (A)
+5V	2.6A

The power supply output establish again within 2s after overload is removed.

#### 6. SAFETY REQUIREMENTS

The power supply must comply with the following national standards:

##### 6.1. DIELECTRIC STRENGTH

Primary to Secondary : 4242 VDC for 3 sec.

##### 6.2. INSULATION RESISTANCE

Primary to secondary : 30 Meg. ohms Min., 500VDC

##### 6.3. GROUND LEAKAGE CURRENT

The power supply ground leakage current shall be less than 100 uA.

#### 7. ELECTROMAGNETIC COMPATIBILITY

Power supply for use with the host system will be tested to conform with the following emission standards.

##### 7.1. FCC REQUIREMENTS

Power supply shall comply with the United States Communication Commission (FCC) Rules and Regulations, Part 15, Subpart J, Computing Devices “Class B limits”.

Customer	Rev.	Written By	Effective Date	LITE-ON Technology Corp.
	X02	Leon Chang	2012/11/12	SHEET 7 of 10
				LTADPDOC-001-0B1



## 7.2. VDE REQUIREMENTS

Power supply shall conform to the "Class B" requirements of CISPR 22.

## 7.3. VCCI REQUIREMENTS

Power supply shall conform to the "Class II" requirements of VCCI.

## 7.4. EMC REQUIREMENTS

### 7.4.1. Immunity requirement

The adapter shall meet the below Immunity requirement based on:

1. IEC 61000-4.2 ESD
2. IEC 61000-4.3 Radiated Immunity
3. IEC 61000-4.4 Electrical Fast Transients
4. IEC 61000-4.5 Surges
5. IEC 61000-4.6 Conducted Immunity
6. IEC 61000-4.11 Voltage Dips

### 7.4.2. Emissions requirement

The adapter shall meet EN55022 Class B

### 7.4.3. Power line Harmonics

The adapter shall meet IEC 1000-3-2 Class D

### 7.4.4. Voltage Fluctuation and Flicker

The adapter shall meet EN610003-3

## 7.5. LIGHTNING SURGE

A  $\pm 1$ K volt (applied differential mode), and a  $\pm 2$ K volt (applied common mode) by IEC 61000-4-5

## 7.6. ESD

The power supply shall meet Contact discharge  $\pm 4.5$ KV and Air discharge  $\pm 9$ KV requirement by IEC 61000-4-2, when power supply is operating at maximum load condition.

## 8. RELIABILITY

### 8.1. MTBF

The PSU Mean Time Between Failures should not less than 150K hours at 25 degree C at nominal input voltage operation conditions.

### 8.2. OPERATION LIFE

The Adaptor shall be designed for a min. life of 15000hrs at 10W load condition, ambient temperature at 25 degree C and nominal input voltage.

## 9. ENVIROMENT

### 9.1. OPERATING

Temperature : 0 to 40 degrees centigrade.

Relative Humidity : 65 to 95 percent RH, non-condensing.

Customer	Rev.	Written By	Effective Date	LITE-ON Technology Corp.
	X02	Leon Chang	2012/11/12	SHEET 8 of 10
				LTADPDOC-001-0B1

**9.2. SHIPPING AND STORAGE**

Temperature : -10 to +70 degrees centigrade.  
 Relative Humidity : 5 to 95 percent RH, non-condensing.

**9.3. ALTITUDE**

Operation : 0-10,000ft  
 Shipping : 0-50,000ft

**9.4. REGULATED SUBSTANCE REQUIREMENT**

The Adaptor shall be designed to meet 100% RoHS requirement.

**10. TEMPERATURE RISE OF CASE SURFACE**

No point on the surface of the adapter case's rise temperature shall be less than **60 deg C with nominal input voltage with any load in 25 degree C ambient** as indicated in section 2.1.

**11. MACHANICAL**

**11.1. DIMENSION**

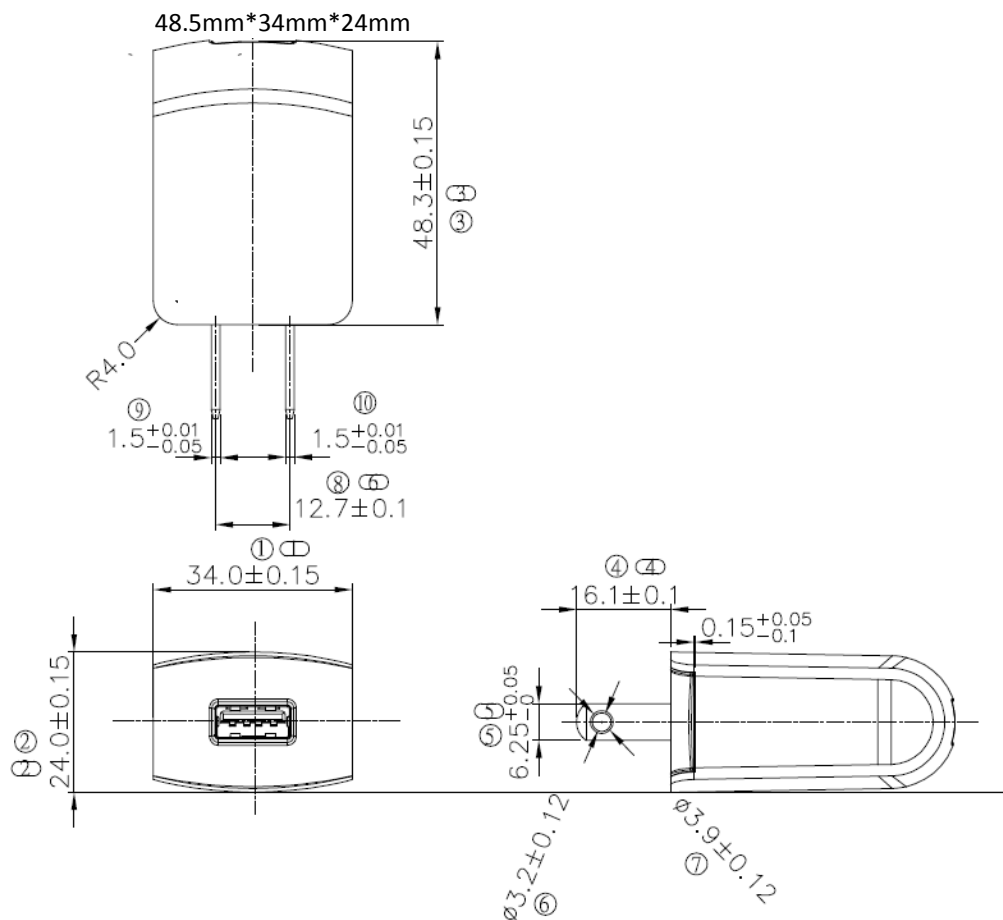

Customer	Rev.	Written By	Effective Date	LITE-ON Technology Corp.
	X02	Leon Chang	2012/11/12	SHEET 9 of 10
				LTADPDOC-001-0B1

**11.2.WEIGHT**

40g(Max.)

**11.3.DC CABLE**

USB 2.0 connector compatible

<b>Customer</b>	<b>Rev.</b>	<b>Written By</b>	<b>Effective Date</b>	<b>LITE-ON Technology Corp.</b>
	X02	<b>Leon Chang</b>	<b>2012/11/12</b>	SHEET 10 of 10
				<b>LTADPDOC-001-0B1</b>