



Chipsmall Limited consists of a professional team with an average of over 10 year of expertise in the distribution of electronic components. Based in Hongkong, we have already established firm and mutual-benefit business relationships with customers from,Europe,America and south Asia,supplying obsolete and hard-to-find components to meet their specific needs.

With the principle of "Quality Parts,Customers Priority,Honest Operation,and Considerate Service",our business mainly focus on the distribution of electronic components. Line cards we deal with include Microchip,ALPS,ROHM,Xilinx,Pulse,ON,Everlight and Freescale. Main products comprise IC,Modules,Potentiometer,IC Socket,Relay,Connector.Our parts cover such applications as commercial,industrial, and automotives areas.

We are looking forward to setting up business relationship with you and hope to provide you with the best service and solution. Let us make a better world for our industry!



Contact us

Tel: +86-755-8981 8866 Fax: +86-755-8427 6832

Email & Skype: info@chipsmall.com Web: www.chipsmall.com

Address: A1208, Overseas Decoration Building, #122 Zhenhua RD., Futian, Shenzhen, China



PACDN004, SZPACDN004

2-Channel ESD Protection Array

Product Description

The PACDN004 is a diode array designed to provide two channels of ESD protection for electronic components or sub-systems. Each channel consists of a pair of diodes which steers the ESD current pulse either to the positive (V_P) or negative (V_N) supply. The PACDN004 will protect against ESD pulses up to ± 15 kV Human Body Model, and ± 8 kV contact discharge per International Standard IEC 61000-4-2.

This device has identical characteristics as the PACDN006 (6-channel array). They can be used together in order to provide a larger number of protected inputs if required. This device is particularly well-suited for a wide range of portable electronics (e.g. cellular phones, PDAs, notebook computers) because of its small package footprint, high ESD protection level and low loading capacitance. It is also suitable for protecting video output lines and I/O ports in computers and peripherals.

The PACDN004 is available with RoHS compliant lead-free finishing.

Features

- Two Channels of ESD Protection
- ± 8 kV Contact, ± 15 kV Air ESD Protection per Channel (IEC 61000-4-2 Standard)
- ± 15 kV of ESD Protection per Channel (HBM)
- Low Loading Capacitance of 3 pF Typical
- Low Leakage Current is Ideal for Battery-Powered Devices
- Miniature 4-Pin SOT-143 Package
- SZ Prefix for Automotive and Other Applications Requiring Unique Site and Control Change Requirements; AEC-Q101 Qualified and PPAP Capable
- These Devices are Pb-Free, Halogen Free/BFR Free and are RoHS Compliant

Applications

- Consumer Electronic Products
- Cellular Phones
- PDAs
- Notebook Computers
- Desktop PCs
- Digital Cameras and Camcorders
- VGA (Video) Port Protection for Desktop and Portable PCs



ON Semiconductor®

www.onsemi.com

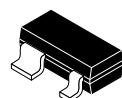

SOT-143
PACDN004SR
CASE 527AF

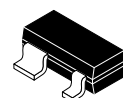

SOT-143
SZPACDN004SR
CASE 318A

SIMPLIFIED ELECTRICAL SCHEMATIC

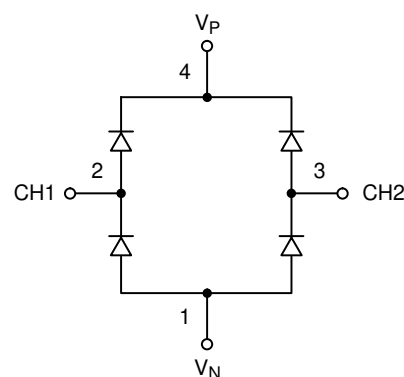

MARKING DIAGRAM

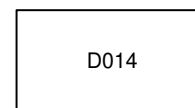

D014 = PACDN004SR

ORDERING INFORMATION

Device	Package	Shipping†
PACDN004SR	SOT-143 (Pb-Free)	3000/Tape & Reel
SZPACDN004SR	SOT-143 (Pb-Free)	3000/Tape & Reel

†For information on tape and reel specifications, including part orientation and tape sizes, please refer to our Tape and Reel Packaging Specification Brochure, BRD8011/D.

PACDN004, SZPACDN004

TYPICAL APPLICATION CIRCUIT

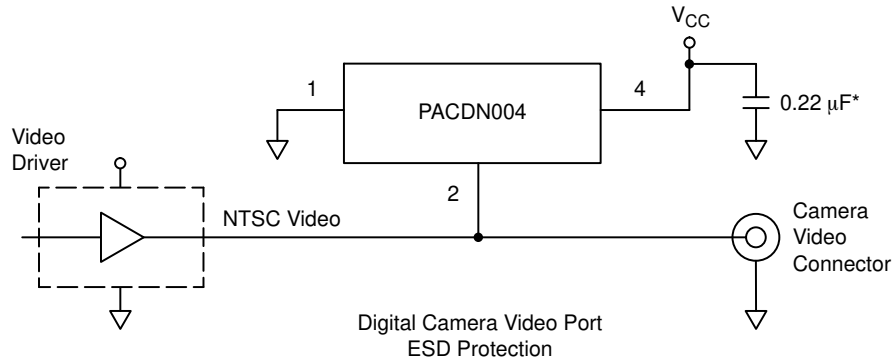

* Decoupling capacitor must be placed as close as possible to Pin4.

PACKAGE / PINOUT DIAGRAM

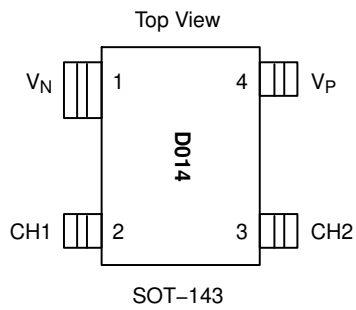

Table 1. PIN DESCRIPTIONS

PACDN004 (SOT-143)			
Pin	Name	Type	Description
1	V _N	GND	Negative Voltage Supply Rail or Ground Reference Rail
2	CH1	I/O	ESD Channel 1
3	CH2	I/O	ESD Channel 2
4	V _P	Supply	Positive Voltage Supply Rail

PACDN004, SZPACDN004

SPECIFICATIONS

Table 2. ABSOLUTE MAXIMUM RATINGS

Parameter	Rating	Units
Supply Voltage ($V_P - V_N$)	6.0	V
Diode Forward DC Current (Note 1)	20	mA
Operating Temperature Range	-40 to +85	°C
Storage Temperature Range	-65 to +150	°C
DC Voltage at any Channel Input	$(V_N - 0.5)$ to $(V_P + 0.5)$	V
Package Power Rating	225	mW

Stresses exceeding those listed in the Maximum Ratings table may damage the device. If any of these limits are exceeded, device functionality should not be assumed, damage may occur and reliability may be affected.

1. Only one diode conducting at a time.

Table 3. STANDARD OPERATING CONDITIONS

Parameter	Rating	Units
Operating Temperature Range	-40 to +85	°C
Operating Supply Voltage ($V_P - V_N$)	0 to 5.5	V

Functional operation above the stresses listed in the Recommended Operating Ranges is not implied. Extended exposure to stresses beyond the Recommended Operating Ranges limits may affect device reliability.

Table 4. ELECTRICAL OPERATING CHARACTERISTICS (Note 1)

Symbol	Parameter	Conditions	Min	Typ	Max	Units
I_P	Supply Current	$(V_P - V_N) = 5.5$ V			10	μ A
V_F	Diode Forward Voltage	$I_F = 20$ mA	0.65		0.95	V
I_{LEAK}	Channel Leakage Current			± 0.1	± 1.0	μ A
C_{IN}	Channel Input Capacitance	@ 1 MHz, $V_P = 5$ V, $V_N = 0$ V, $V_{IN} = 2.5$ V		3	5	pF
V_{ESD}	ESD Protection Peak Discharge Voltage at any Channel Input, in System a) Human Body Model, MIL-STD-883, Method 3015 b) Contact Discharge per IEC 61000-4-2 Standard c) Air Discharge per IEC 61000-4-2	(Note 2) (Notes 2 and 3) (Notes 2 and 4) (Notes 2 and 4)	 ± 15 ± 8 ± 15			kV
V_{CL}	Channel Clamp Voltage Positive Transients Negative Transients	@ 15 kV ESD HBM (Notes 2 and 3)			 $V_P + 13.0$ $V_N - 13.0$	V

Product parametric performance is indicated in the Electrical Characteristics for the listed test conditions, unless otherwise noted. Product performance may not be indicated by the Electrical Characteristics if operated under different conditions.

1. All parameters specified at $T_A = 25^\circ\text{C}$ unless otherwise noted. $V_P = 5$ V, $V_N = 0$ V unless noted.
2. From I/O pins to V_P or V_N only. V_P bypassed to V_N with a 0.22 μ F ceramic capacitor (see Application Information for more details).
3. Human Body Model per MIL-STD-883, Method 3015, $C_{Discharge} = 100$ pF, $R_{Discharge} = 1.5$ k Ω , $V_P = 5.0$ V, V_N grounded.
4. Standard IEC 61000-4-2 with $C_{Discharge} = 150$ pF, $R_{Discharge} = 330$ Ω , $V_P = 5.0$ V, V_N grounded.

PACDN004, SZPACDN004

PERFORMANCE INFORMATION

Input Capacitance vs. Input Voltage

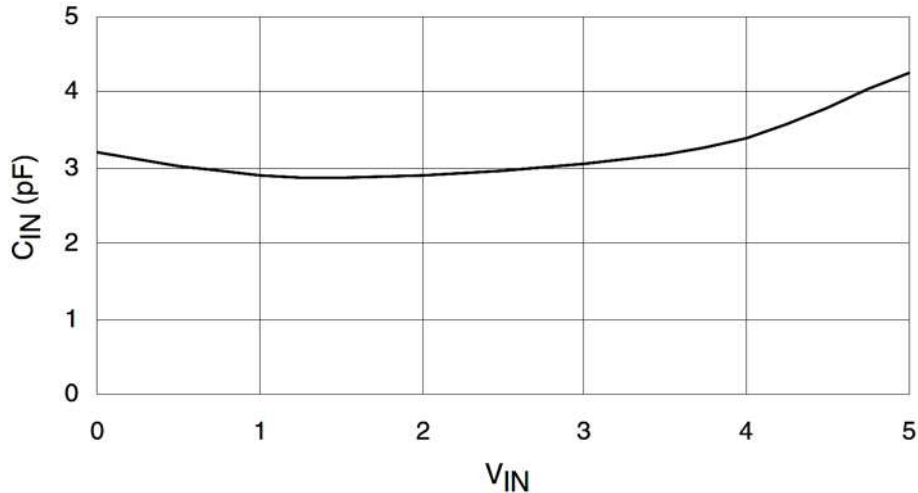

Figure 1. Typical Variation of C_{IN} vs. V_{IN}
(V_P = 5 V, V_N = 0 V, 0.1 μF Chip Capacitor between V_P and V_N)

APPLICATION INFORMATION

Design Considerations

In order to realize the maximum protection against ESD pulses, care must be taken in the PCB layout to minimize parasitic series inductances on the Supply/Ground rails as well as the signal trace segment between the signal input (typically a connector) and the ESD protection device. Refer to Application of Positive ESD Pulse between Input Channel and Ground, which illustrates an example of a positive ESD pulse striking an input channel. The parasitic series inductance back to the power supply is represented by L₁ and L₂. The voltage V_{CL} on the line being protected is:

$$V_{CL} = \text{Fwd Voltage Drop of } D_1 + V_{SUPPLY} + L_1 \times d(I_{ESD})/dt + L_2 \times d(I_{ESD})/dt$$

where I_{ESD} is the ESD current pulse, and V_{SUPPLY} is the positive supply voltage.

An ESD current pulse can rise from zero to its peak value in a very short time. As an example, a level 4 contact discharge per the IEC61000-4-2 standard results in a current pulse that rises from zero to 30 Amps in 1 ns. Here d(I_{ESD})/dt can be approximated by ΔI_{ESD}/Δt, or 30/(1x10⁻⁹). So just 10 nH of series inductance (L₁ and L₂ combined) will lead to a 300 V increment in V_{CL}!

Similarly for negative ESD pulses, parasitic series inductance from the V_N pin to the ground rail will lead to drastically increased negative voltage on the line being protected.

Another consideration is the output impedance of the power supply for fast transient currents. Most power supplies exhibit a much higher output impedance to fast transient current spikes. In the V_{CL} equation above, the V_{SUPPLY} term, in reality, is given by (V_{DC} + I_{ESD} × R_{OUT}), where V_{DC} and R_{OUT} are the nominal supply DC output voltage and effective output impedance of the power supply respectively. As an example, a R_{OUT} of 1 Ω would result in a 10 V increment in V_{CL} for a peak I_{ESD} of 10 A.

If the inductances and resistance described above are close to zero, the rail-clamp ESD protection diodes will do a good job of protection. However, since this is not possible in practical situations, a bypass capacitor must be used to absorb the very high frequency ESD energy. So for any brand of rail-clamp ESD protection diodes, a bypass capacitor should be connected between the V_P pin of the diodes and the ground plane (V_N pin of the diodes) as shown in the Application Circuit diagram below. A value of 0.22 μF is adequate for IEC-61000-4-2 level 4 contact discharge protection (±8 kV). Ceramic chip capacitors mounted with short printed circuit board traces are good choices for this application. Electrolytic capacitors should be avoided as they have poor high frequency characteristics. For extra protection, connect a zener diode in parallel with the bypass capacitor to mitigate

PACDN004, SZPACDN004

the effects of the parasitic series inductance inherent in the capacitor. The breakdown voltage of the zener diode should be slightly higher than the maximum supply voltage.

As a general rule, the ESD Protection Array should be located as close as possible to the point of entry of expected electrostatic discharges. The power supply bypass capacitor mentioned above should be as close to the V_P pin of the Protection Array as possible, with minimum PCB trace lengths to the power supply, ground planes and between the signal input and the ESD device to minimize stray series inductance.

Additional Information

See also ON Semiconductor Application Notes AP209, "Design Considerations for ESD Protection" and AP219, "ESD Protection for USB 2.0 Systems".

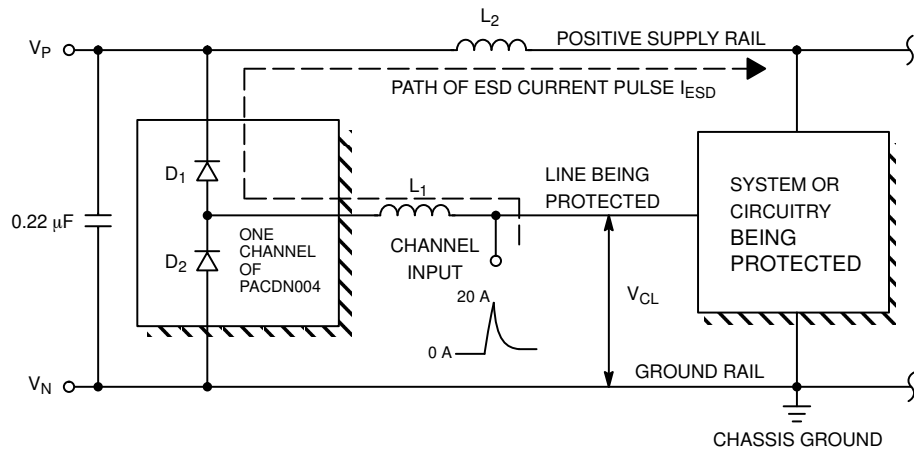
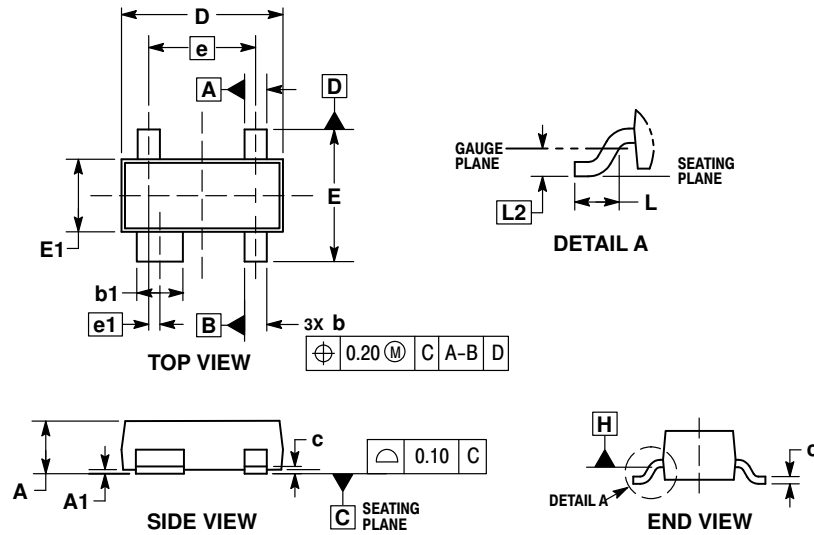

Figure 2. Application of Positive ESD Pulse between Input Channel and Ground

PACDN004, SZPACDN004

PACKAGE DIMENSIONS

SOT-143
CASE 318A-06
ISSUE U



NOTES:

1. DIMENSIONING AND TOLERANCING PER ASME Y14.5M, 1994.
2. CONTROLLING DIMENSION: MILLIMETERS.
3. MAXIMUM LEAD THICKNESS INCLUDES LEAD FINISH. MINIMUM LEAD THICKNESS IS THE MINIMUM THICKNESS OF BASE MATERIAL.
4. DIMENSIONS D AND E DO NOT INCLUDE MOLD FLASH, PROTRUSIONS, OR GATE BURRS. MOLD FLASH, PROTRUSIONS, AND GATE BURRS SHALL NOT EXCEED 0.25 PER SIDE. DIMENSION E1 DOES NOT INCLUDE INTERLEAD FLASH OR PROTRUSION. INTERLEAD FLASH AND PROTRUSION SHALL NOT EXCEED 0.25 PER SIDE.
5. DIMENSIONS D AND E1 ARE DETERMINED AT DATUM H.
6. DATUMS A AND B ARE DETERMINED AT DATUM H.

DIM	MILLIMETERS	
	MIN	MAX
A	0.80	1.12
A1	0.01	0.15
b	0.30	0.51
b1	0.76	0.94
c	0.08	0.20
D	2.80	3.05
E	2.10	2.64
E1	1.20	1.40
e	1.92 BSC	
e1	0.20 BSC	
L	0.35	0.70
L2	0.25 BSC	

RECOMMENDED SOLDERING FOOTPRINT

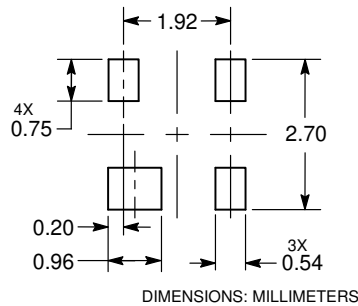

PACDN004, SZPACDN004

PACKAGE DIMENSIONS

SOT-143, 4 Lead
CASE 527AF
ISSUE A

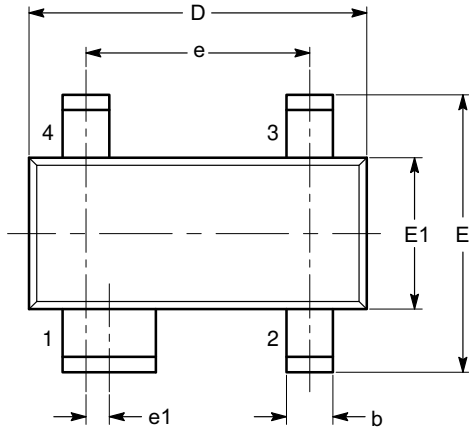

TOP VIEW

SYMBOL	MIN	NOM	MAX
A	0.80		1.22
A1	0.05		0.15
A2	0.75	0.90	1.07
b	0.30		0.50
b2	0.76		0.89
c	0.08		0.20
D	2.80	2.90	3.04
E	2.10		2.64
E1	1.20	1.30	1.40
e	1.92 BSC		
e1	0.20 BSC		
L	0.40	0.50	0.60
L1	0.54 REF		
L2		0.25	
θ	0°		8°

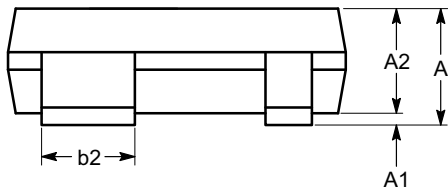

SIDE VIEW

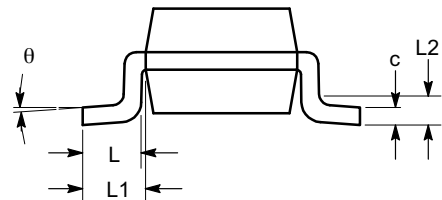

END VIEW

Notes:

- (1) All dimensions are in millimeters. Angles in degrees.
- (2) Complies with JEDEC TO-253.

ON Semiconductor and  are registered trademarks of Semiconductor Components Industries, LLC (SCILLC). SCILLC reserves the right to make changes without further notice to any products herein. SCILLC makes no warranty, representation or guarantee regarding the suitability of its products for any particular purpose, nor does SCILLC assume any liability arising out of the application or use of any product or circuit, and specifically disclaims any and all liability, including without limitation special, consequential or incidental damages. "Typical" parameters which may be provided in SCILLC data sheets and/or specifications can and do vary in different applications and actual performance may vary over time. All operating parameters, including "Typicals" must be validated for each customer application by customer's technical experts. SCILLC does not convey any license under its patent rights nor the rights of others. SCILLC products are not designed, intended, or authorized for use as components in systems intended for surgical implant into the body, or other applications intended to support or sustain life, or for any other application in which the failure of the SCILLC product could create a situation where personal injury or death may occur. Should Buyer purchase or use SCILLC products for any such unintended or unauthorized application, Buyer shall indemnify and hold SCILLC and its officers, employees, subsidiaries, affiliates, and distributors harmless against all claims, costs, damages, and expenses, and reasonable attorney fees arising out of, directly or indirectly, any claim of personal injury or death associated with such unintended or unauthorized use, even if such claim alleges that SCILLC was negligent regarding the design or manufacture of the part. SCILLC is an Equal Opportunity/Affirmative Action Employer. This literature is subject to all applicable copyright laws and is not for resale in any manner.

PUBLICATION ORDERING INFORMATION

LITERATURE FULFILLMENT:
Literature Distribution Center for ON Semiconductor
P.O. Box 5163, Denver, Colorado 80217 USA
Phone: 303-675-2175 or 800-344-3860 Toll Free USA/Canada
Fax: 303-675-2176 or 800-344-3867 Toll Free USA/Canada
Email: orderlit@onsemi.com

N. American Technical Support: 800-282-9855 Toll Free
USA/Canada
Europe, Middle East and Africa Technical Support:
Phone: 421 33 790 2910
Japan Customer Focus Center
Phone: 81-3-5817-1050

ON Semiconductor Website: www.onsemi.com
Order Literature: <http://www.onsemi.com/orderlit>
For additional information, please contact your local Sales Representative