



Chipsmall Limited consists of a professional team with an average of over 10 year of expertise in the distribution of electronic components. Based in Hongkong, we have already established firm and mutual-benefit business relationships with customers from,Europe,America and south Asia,supplying obsolete and hard-to-find components to meet their specific needs.

With the principle of “Quality Parts,Customers Priority,Honest Operation,and Considerate Service”,our business mainly focus on the distribution of electronic components. Line cards we deal with include Microchip,ALPS,ROHM,Xilinx,Pulse,ON,Everlight and Freescale. Main products comprise IC,Modules,Potentiometer,IC Socket,Relay,Connector.Our parts cover such applications as commercial,industrial, and automotives areas.

We are looking forward to setting up business relationship with you and hope to provide you with the best service and solution. Let us make a better world for our industry!



## Contact us

Tel: +86-755-8981 8866 Fax: +86-755-8427 6832

Email & Skype: info@chipsmall.com Web: www.chipsmall.com

Address: A1208, Overseas Decoration Building, #122 Zhenhua RD., Futian, Shenzhen, China





CYPRESS

PALCE16V8

# Flash Erasable, Reprogrammable CMOS PAL<sup>®</sup> Device

## Features

- Active pull-up on data input pins
  - Low power version (16V8L)
    - 55 mA max. commercial (10, 15, 25 ns)
    - 65 mA max. industrial (10, 15, 25 ns)
    - 65 mA military (15 and 25 ns)
  - Standard version has low power
    - 90 mA max. commercial (10, 15, 25 ns)
    - 115 mA max. commercial (7 ns)
    - 130 mA max. military/industrial (10, 15, 25 ns)
  - CMOS Flash technology for electrical erasability and reprogrammability
  - PCI compliant
  - User-programmable macrocell
    - Output polarity control
    - Individually selectable for registered or combinatorial operation
- Up to 16 input terms and 8 outputs
  - 7.5 ns com'l version
    - 5 ns  $t_{CO}$
    - 5 ns  $t_S$
    - 7.5 ns  $t_{PD}$
    - 125-MHz state machine
  - 10 ns military/industrial versions
    - 7 ns  $t_{CO}$
    - 10 ns  $t_S$
    - 10 ns  $t_{PD}$
    - 62-MHz state machine
  - High reliability
    - Proven Flash technology
    - 100% programming and functional testing

## Functional Description

The Cypress PALCE16V8 is a CMOS Flash Electrical Erasable second-generation programmable array logic device. It is implemented with the familiar sum-of-product (AND-OR) logic structure and the programmable macrocell.

## Logic Block Diagram (PDIP/CDIP)

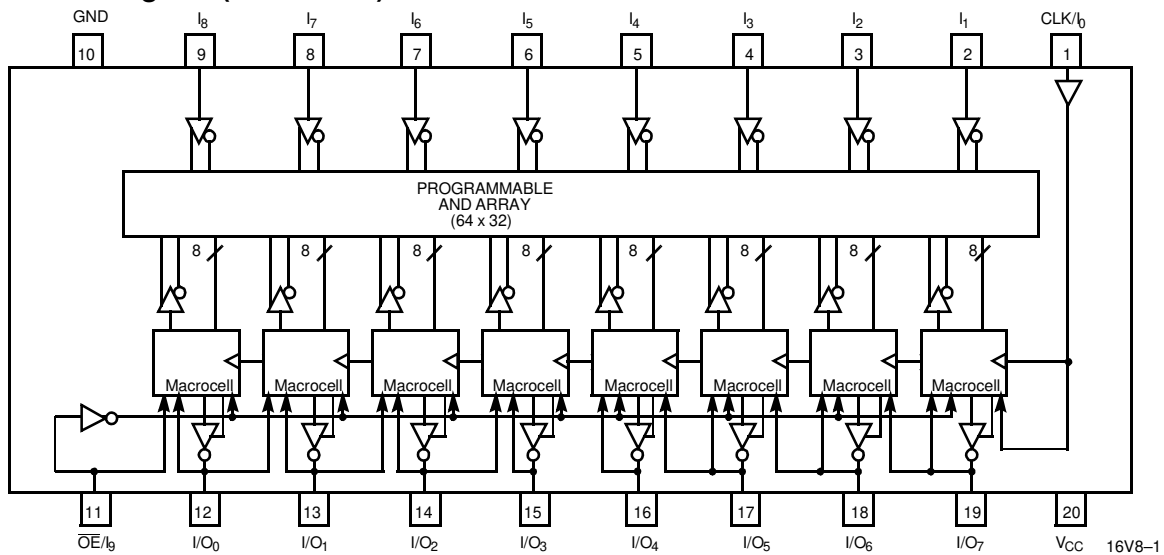

## Pin Configurations

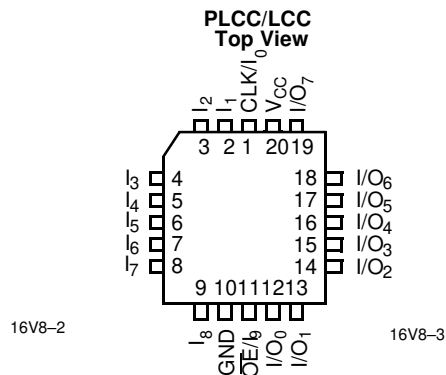
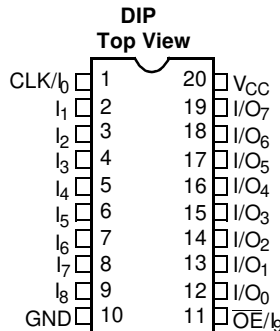

**Selection Guide**

Generic Part Number	$t_{PD}$ ns		$t_S$ ns		$t_{CO}$ ns		$I_{CC}$ mA	
	Com'l/Ind	Mil	Com'l/Ind	Mil	Com'l/Ind	Mil	Com'l	Mil/Ind
<b>PALCE16V8-5</b>	5		3		4		115	
<b>PALCE16V8-7</b>	7.5		7		5		115	
<b>PALCE16V8-10</b>	10	10	10	10	7	10	90	130
<b>PALCE16V8-15</b>	15	15	12	12	10	10	90	130
<b>PALCE16V8-25</b>	25	25	15	20	12	12	90	130
<b>PALCE16V8L-15</b>	15	15	12	12	10	12	55	65
<b>PALCE16V8L-25</b>	25	25	15	20	12	20	55	65

Shaded area contains preliminary information.

**Functional Description** (continued)

The PALCE16V8 is executed in a 20-pin 300-mil molded DIP, a 300-mil cerdip, a 20-lead square ceramic leadless chip carrier, and a 20-lead square plastic leaded chip carrier.

The device provides up to 16 inputs and 8 outputs. The PALCE16V8 can be electrically erased and reprogrammed. The programmable macrocell enables the device to function as a superset to the familiar 20-pin PLDs such as 16L8, 16R8, 16R6, and 16R4.

The PALCE16V8 features 8 product terms per output and 32 input terms into the AND array. The first product term in a macrocell can be used either as an internal output enable control or as a data product term.

There are a total of 18 architecture bits in the PALCE16V8 macrocell; two are global bits that apply to all macrocells and 16 that apply locally, two bits per macrocell. The architecture bits determine whether the macrocell functions as a register or combinatorial with inverting or noninverting output. The output enable control can come from an external pin or internally from a product term. The output can also be permanently enabled, functioning as a dedicated output or permanently disabled, functioning as a dedicated input. Feedback paths are selectable from either the input/output pin associated with the macrocell, the input/output pin associated with an adjacent pin, or from the macrocell register itself.

**Configuration Table**

$CG_0$	$CG_1$	$CL0_x$	Cell Configuration	Devices Emulated
0	1	0	Registered Output	Registered Med PALs
0	1	1	Combinatorial I/O	Registered Med PALs
1	0	0	Combinatorial Output	Small PALs
1	0	1	Input	Small PALs
1	1	1	Combinatorial I/O	16L8 only

**Power-Up Reset**

All registers in the PALCE16V8 power-up to a logic LOW for predictable system initialization. For each register, the associated output pin will be HIGH due to active-LOW outputs.

**Electronic Signature**

An electronic signature word is provided in the PALCE16V8 that consists of 64 bits of programmable memory that can contain user-defined data.

**Security Bit**

A security bit is provided that defeats the readback of the internal programmed pattern when the bit is programmed.

**Low Power**

The Cypress PALCE16V8 provides low-power operation through the use of CMOS technology, and increased testability with Flash reprogrammability.

**Product Term Disable**

Product Term Disable (PTD) fuses are included for each product term. The PTD fuses allow each product term to be individually disabled.

Macrocell

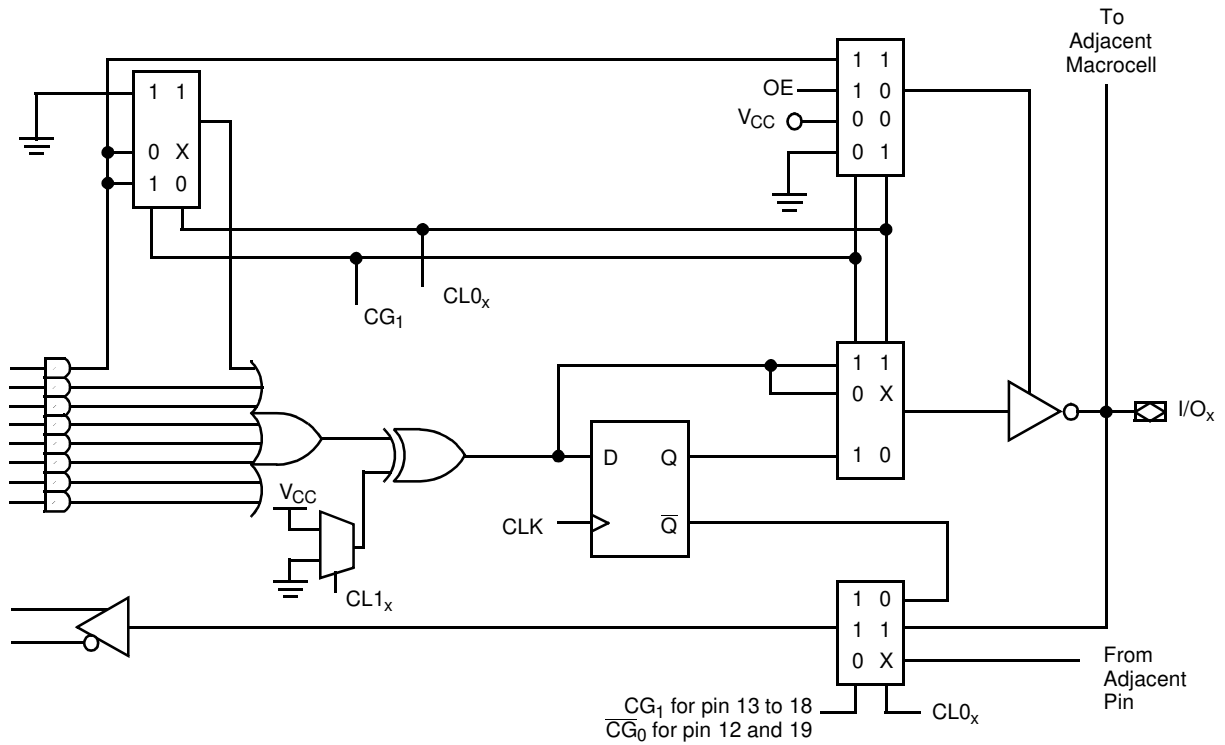

16V8-4

### Maximum Ratings

(Above which the useful life may be impaired. For user guidelines, not tested.)

Storage Temperature .....	-65°C to +150°C
Ambient Temperature with Power Applied.....	-55°C to +125°C
Supply Voltage to Ground Potential (Pin 24 to Pin 12) .....	-0.5V to +7.0V
DC Voltage Applied to Outputs in High Z State .....	-0.5V to +7.0V
DC Input Voltage.....	-0.5V to +7.0V

Output Current into Outputs (LOW).....	24 mA
DC Programming Voltage.....	12.5V
Latch-Up Current.....	>200 mA

### Operating Range

Range	Ambient Temperature	V <sub>CC</sub>
Commercial	0°C to +75°C	5V ±5%
Military <sup>[1]</sup>	-55°C to +125°C	5V ±10%
Industrial	-40°C to +85°C	5V ±10%

### Electrical Characteristics Over the Operating Range<sup>[2]</sup>

Parameter	Description	Test Conditions			Min.	Max.	Unit	
V <sub>OH</sub>	Output HIGH Voltage	V <sub>CC</sub> = Min., V <sub>IN</sub> = V <sub>IH</sub> or V <sub>IL</sub>	I <sub>OH</sub> = -3.2 mA	Com'l	2.4		V	
			I <sub>OH</sub> = -2 mA	Mil/Ind				
V <sub>OL</sub>	Output LOW Voltage	V <sub>CC</sub> = Min., V <sub>IN</sub> = V <sub>IH</sub> or V <sub>IL</sub>	I <sub>OL</sub> = 24 mA	Com'l		0.5	V	
			I <sub>OL</sub> = 12 mA	Mil/Ind				
V <sub>IH</sub>	Input HIGH Level	Guaranteed Input Logical HIGH Voltage for All Inputs <sup>[3]</sup>			2.0		V	
V <sub>IL</sub> <sup>[4]</sup>	Input LOW Level	Guaranteed Input Logical LOW Voltage for All Inputs <sup>[3]</sup>			-0.5	0.8	V	
I <sub>IH</sub>	Input or I/O HIGH Leakage Current	3.5V ≤ V <sub>IN</sub> ≤ V <sub>CC</sub>				10	μA	
I <sub>IL</sub> <sup>[5]</sup>	Input or I/O LOW Leakage Current	0V ≤ V <sub>IN</sub> ≤ V <sub>IN</sub> (Max.)				-100	μA	
I <sub>SC</sub>	Output Short Circuit Current	V <sub>CC</sub> = Max., V <sub>OUT</sub> = 0.5V <sup>[6, 7]</sup>			-30	-150	mA	
I <sub>CC</sub>	Operating Power Supply Current	V <sub>CC</sub> = Max., V <sub>IL</sub> = 0V, V <sub>IH</sub> = 3V, Output Open, f = 15 MHz (counter)	5, 7 ns	Com'l		115	mA	
			10, 15, 25 ns			90	mA	
			15L, 25L ns			55	mA	
			10, 15, 25 ns	Mil/Ind		130	mA	
			15L, 25L ns		Mil.		65	mA
			15L, 25L ns		Ind.		65	mA

### Capacitance<sup>[7]</sup>

Parameter	Description	Test Conditions	Typ.	Unit
C <sub>IN</sub>	Input Capacitance	V <sub>IN</sub> = 2.0V @ f = 1 MHz	5	pF
C <sub>OUT</sub>	Output Capacitance	V <sub>OUT</sub> = 2.0V @ f = 1 MHz	5	pF

### Endurance Characteristics<sup>[7]</sup>

Parameter	Description	Test Conditions	Min.	Max.	Unit
N	Minimum Reprogramming Cycles	Normal Programming Conditions	100		Cycles

#### Notes:

- T<sub>A</sub> is the "instant on" case temperature.
- See the last page of this specification for Group A subgroup testing information.
- These are absolute values with respect to device ground. All overshoots due to system or tester noise are included.
- V<sub>IL</sub> (Min.) is equal to -3.0V for pulse durations less than 20 ns.
- The leakage current is due to the internal pull-up resistor on all pins.
- Not more than one output should be tested at a time. Duration of the short circuit should not be more than one second. V<sub>OUT</sub> = 0.5V has been chosen to avoid test problems caused by tester ground degradation.
- Tested initially and after any design or process changes that may affect these parameters.

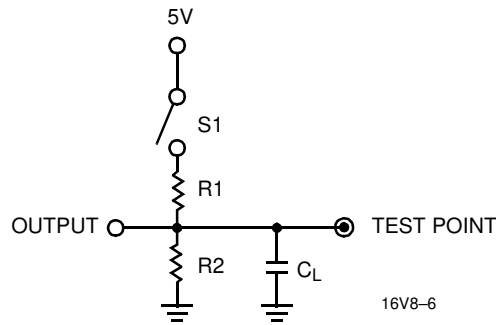
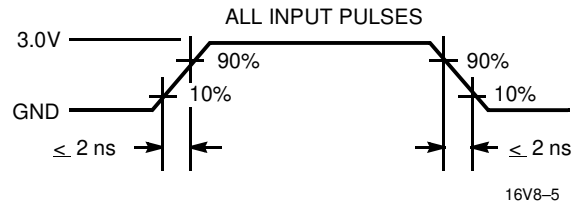
**AC Test Loads and Waveforms**

Specification	S <sub>1</sub>	C <sub>L</sub>	Commercial		Military		Measured Output Value
			R <sub>1</sub>	R <sub>2</sub>	R <sub>1</sub>	R <sub>2</sub>	
t <sub>PD</sub> , t <sub>CO</sub>	Closed	50 pF	200Ω	390Ω	390Ω	750Ω	1.5V
t <sub>PZX</sub> , t <sub>EA</sub>	Z · H: Open Z · L: Closed						1.5V
t <sub>PXZ</sub> , t <sub>ER</sub>	H · Z: Open L · Z: Closed	5 pF					H · Z: V <sub>OH</sub> - 0.5V L · Z: V <sub>OL</sub> + 0.5V

**Commercial and Industrial Switching Characteristics<sup>[2]</sup>**

Parameter	Description	16V8-5		16V8-7		16V8-10		16V8-15		16V8-25		Unit
		Min.	Max.	Min.	Max.	Min.	Max.	Min.	Max.	Min.	Max.	
t <sub>PD</sub>	Input to Output Propagation Delay <sup>[8, 9]</sup>	1	5	3	7.5	3	10	3	15	3	25	ns
t <sub>PZX</sub>	$\overline{OE}$ to Output Enable	1	6		6		10		15		20	ns
t <sub>PXZ</sub>	$\overline{OE}$ to Output Disable	1	5		6		10		15		20	ns
t <sub>EA</sub>	Input to Output Enable Delay <sup>[7]</sup>	1	6		9		10		15		25	ns
t <sub>ER</sub>	Input to Output Disable Delay <sup>[7, 10]</sup>	1	5		9		10		15		25	ns
t <sub>CO</sub>	Clock to Output Delay <sup>[8,9]</sup>	1	4	2	5	2	7	2	10	2	12	ns
t <sub>S</sub>	Input or Feedback Set-Up Time	3		5		7.5		12		15		ns
t <sub>H</sub>	Input Hold Time	0		0		0		0		0		ns
t <sub>P</sub>	External Clock Period (t <sub>CO</sub> + t <sub>S</sub> )	7		10		14.5		22		27		ns
t <sub>WH</sub>	Clock Width HIGH <sup>[7]</sup>	3		4		6		8		12		ns
t <sub>WL</sub>	Clock Width LOW <sup>[7]</sup>	3		4		6		8		12		ns
f <sub>MAX1</sub>	External Maximum Frequency (1/(t <sub>CO</sub> + t <sub>S</sub> )) <sup>[7, 11]</sup>	143		100		69		45.5		37		MHz
f <sub>MAX2</sub>	Data Path Maximum Frequency (1/(t <sub>WH</sub> + t <sub>WL</sub> )) <sup>[7, 12]</sup>	166		125		83		62.5		41.6		MHz
f <sub>MAX3</sub>	Internal Feedback Maximum Frequency (1/(t <sub>CF</sub> + t <sub>S</sub> )) <sup>[7, 13]</sup>	166		125		74		50		40		MHz
t <sub>CF</sub>	Register Clock to Feedback Input <sup>[7, 14]</sup>		3		3		6		8		10	ns
t <sub>PR</sub>	Power-Up Reset Time <sup>[7]</sup>	1		1		1		1		1		μs

Shaded area contains preliminary information.

**Notes:**

8. Min. times are tested initially and after any design or process changes that may affect these parameters.
9. This specification is guaranteed for all device outputs changing state in a given access cycle.
10. This parameter is measured as the time after OE pin or internal disable input disables or enables the output pin. This delay is measured to the point at which a previous HIGH level has fallen to 0.5 volts below V<sub>OH</sub> min. or a previous LOW level has risen to 0.5 volts above V<sub>OL</sub> max.
11. This specification indicates the guaranteed maximum frequency at which a state machine configuration with external feedback can operate.
12. This specification indicates the guaranteed maximum frequency at which the device can operate in data path mode.
13. This specification indicates the guaranteed maximum frequency at which a state machine configuration with internal only feedback can operate.
14. This parameter is calculated from the clock period at f<sub>MAX</sub> internal (1/f<sub>MAX3</sub>) as measured (see Note 7 above) minus t<sub>S</sub>.

**Military Switching Characteristics<sup>[7]</sup>**

Parameter	Description	16V8-10		16V8-15		16V8-25		Unit
		Min.	Max.	Min.	Max.	Min.	Max.	
$t_{PD}$	Input to Output Propagation Delay <sup>[8, 9]</sup>	3	10	3	15	3	25	ns
$t_{PZX}$	$\overline{OE}$ to Output Enable		10		15		20	ns
$t_{PXZ}$	$\overline{OE}$ to Output Disable		10		15		20	ns
$t_{EA}$	Input to Output Enable Delay <sup>[7]</sup>		10		15		25	ns
$t_{ER}$	Input to Output Disable Delay <sup>[7, 10]</sup>		10		15		25	ns
$t_{CO}$	Clock to Output Delay <sup>[8, 9]</sup>	2	7	2	10	2	12	ns
$t_S$	Input or Feedback Set-Up Time	10		12		15		ns
$t_H$	Input Hold Time	.5		.5		.5		ns
$t_P$	External Clock Period ( $t_{CO} + t_S$ )	17		22		27		ns
$t_{WH}$	Clock Width HIGH <sup>[7]</sup>	6		8		12		ns
$t_{WL}$	Clock Width LOW <sup>[7]</sup>	6		8		12		ns
$f_{MAX1}$	External Maximum Frequency ( $1/(t_{CO} + t_S)$ ) <sup>[7, 11]</sup>	58		45.5		37		MHz
$f_{MAX2}$	Data Path Maximum Frequency ( $1/(t_{WH} + t_{WL})$ ) <sup>[7, 12]</sup>	83		62.5		41.6		MHz
$f_{MAX3}$	Internal Feedback Maximum Frequency ( $1/(t_{CF} + t_S)$ ) <sup>[7, 13]</sup>	62.5		50		40		MHz
$t_{CF}$	Register Clock to Feedback Input <sup>[7, 14]</sup>		6		8		10	ns
$t_{PR}$	Power-Up Reset Time <sup>[7]</sup>	1		1		1		$\mu$ s

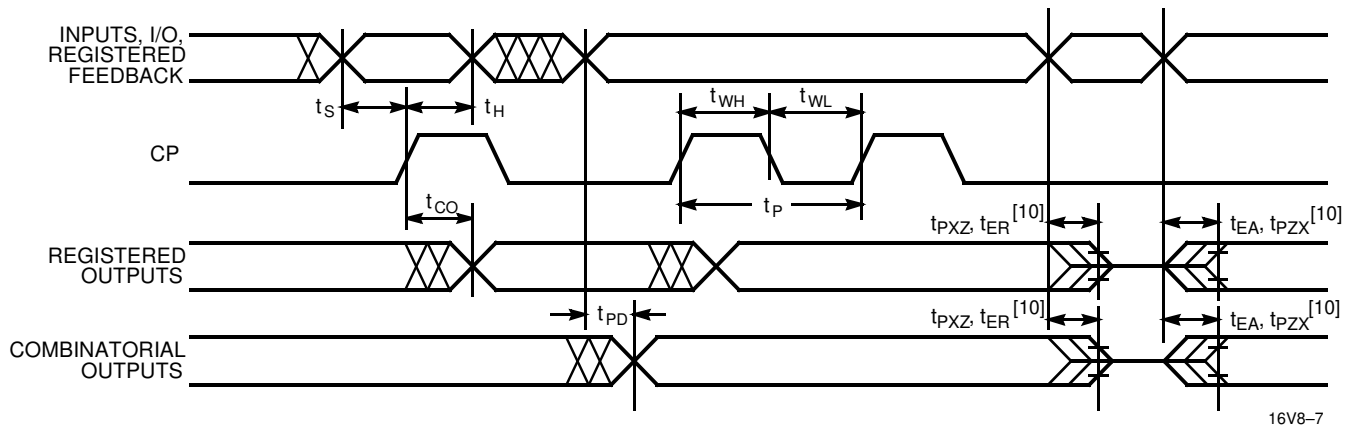
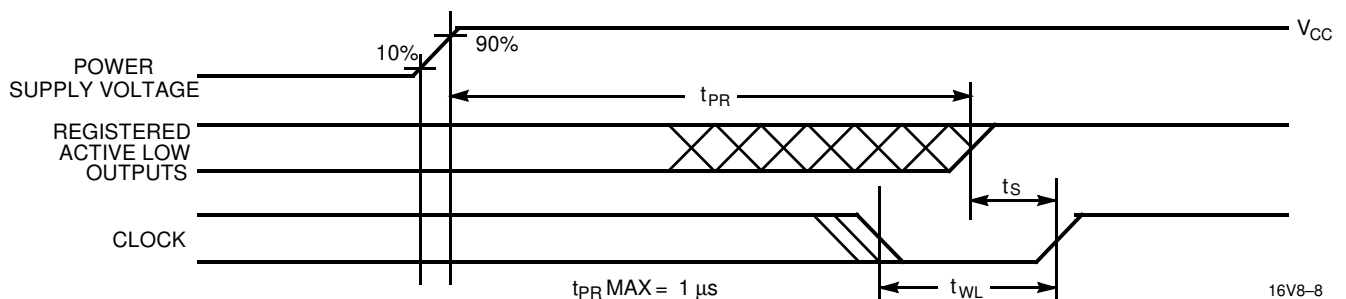
**Switching Waveform**

**Power-Up Reset Waveform**

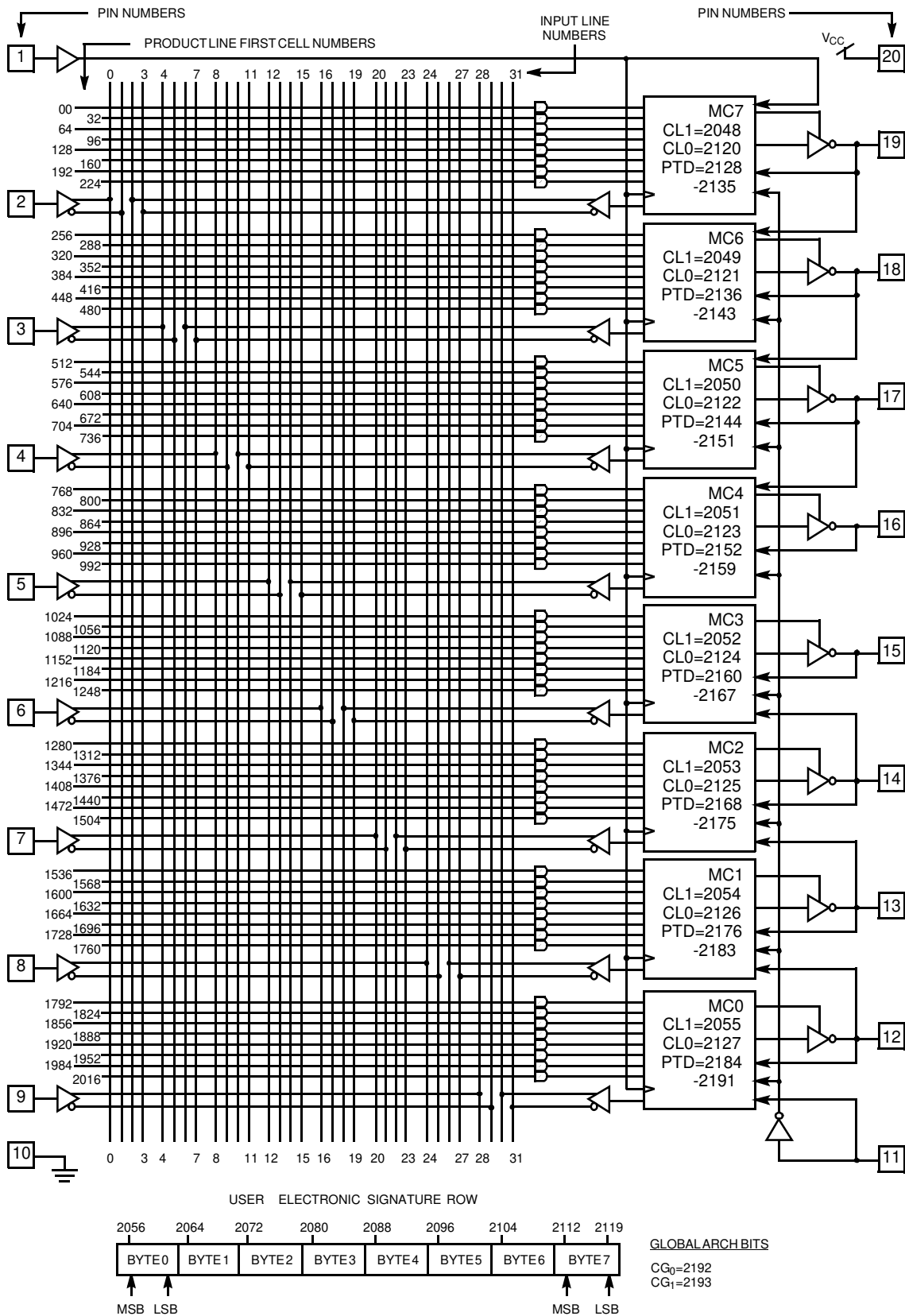

**Functional Logic Diagram for PALCE16V8**

**Ordering Information**

$I_{CC}$ (mA)	$t_{PD}$ (ns)	$t_S$ (ns)	$t_{CO}$ (ns)	Ordering Code	Package Name	Package Type	Operating Range
115	5	3	4	PALCE16V8-5JC	J61	20-Lead Plastic Leaded Chip Carrier	Commercial
115	7.5	5	5	PALCE16V8-7JC	J61	20-Lead Plastic Leaded Chip Carrier	Commercial
				PALCE16V8-7PC	P5	20-Lead (300-Mil) Molded DIP	
90	10	7.5	7	PALCE16V8-10JC	J61	20-Lead Plastic Leaded Chip Carrier	Commercial
				PALCE16V8-10PC	P5	20-Lead (300-Mil) Molded DIP	
130	10	7.5	7	PALCE16V8-10JI	J61	20-Lead Plastic Leaded Chip Carrier	Industrial
				PALCE16V8-10PI	P5	20-Lead (300-Mil) Molded DIP	
130	10	10	7	PALCE16V8-10DMB	D6	20-Lead (300-Mil) CerDIP	Military
				PALCE16V8-10LMB	L61	20-Pin Square Leadless Chip Carrier	
90	15	12	10	PALCE16V8-15JC	J61	20-Lead Plastic Leaded Chip Carrier	Commercial
				PALCE16V8-15PC	P5	20-Lead (300-Mil) Molded DIP	
130	15	12	10	PALCE16V8-15PI	P5	20-Lead(300Mil) Molded DIP	Industrial
				PALCE16V8-15DMB	D6	20-Lead (300-Mil) CerDIP	Military
				PALCE16V8-15LMB	L61	20-Pin Square Leadless Chip Carrier	
90	25	15	12	PALCE16V8-25JC	J61	20-Lead Plastic Leaded Chip Carrier	Commercial
				PALCE16V8-25PC	P5	20-Lead (300-Mil) Molded DIP	
130	25	15	12	PALCE16V8-25JI	J61	20-Lead Plastic Leaded Chip Carrier	Industrial
				PALCE16V8-25DMB	D6	20-Lead (300-Mil) CerDIP	Military
				PALCE16V8-25LMB	L61	20-Pin Square Leadless Chip Carrier	
55	10	7.5	7	PALCE16V8L-10JC	J61	20-Lead Plastic Leaded Chip Carrier	Commercial
				PALCE16V8L-10PC	P5	20-Lead (300-Mil) Molded DIP	
65	10	10	7	PALCE16V8L-10JI	J61	20-Lead Plastic Leaded Chip Carrier	Industrial
				PALCE16V8L-10PI	P5	20-Lead (300-Mil) Molded DIP	
55	15	12	10	PALCE16V8L-15JC	J61	20-Lead Plastic Leaded Chip Carrier	Commercial
				PALCE16V8L-15PC	P5	20-Lead (300-Mil) Molded DIP	
65	15	12	10	PALCE16V8L-15DMB	D6	20-Lead (300-Mil) CerDIP	Military
				PALCE16V8L-15LMB	L61	20-Pin Square Leadless Chip Carrier	
55	25	15	12	PALCE16V8L-25JC	J61	20-Lead Plastic Leaded Chip Carrier	Commercial
				PALCE16V8L-25PC	P5	20-Lead (300-Mil) Molded DIP	
65	25	15	12	PALCE16V8L-25DMB	D6	20-Lead (300-Mil) CerDIP	Military
				PALCE16V8L-25LMB	L61	20-Pin Square Leadless Chip Carrier	

Shaded area contains preliminary information.

**MILITARY SPECIFICATIONS  
Group A Subgroup Testing  
DC Characteristics**

Parameter	Subgroups
V <sub>OH</sub>	1, 2, 3
V <sub>OL</sub>	1, 2, 3
V <sub>IH</sub>	1, 2, 3
V <sub>IL</sub>	1, 2, 3
I <sub>IX</sub>	1, 2, 3
I <sub>OZ</sub>	1, 2, 3
I <sub>CC</sub>	1, 2, 3

**Switching Characteristics**

Parameter	Subgroups
t <sub>PD</sub>	9, 10, 11
t <sub>CO</sub>	9, 10, 11
t <sub>S</sub>	9, 10, 11
t <sub>H</sub>	9, 10, 11

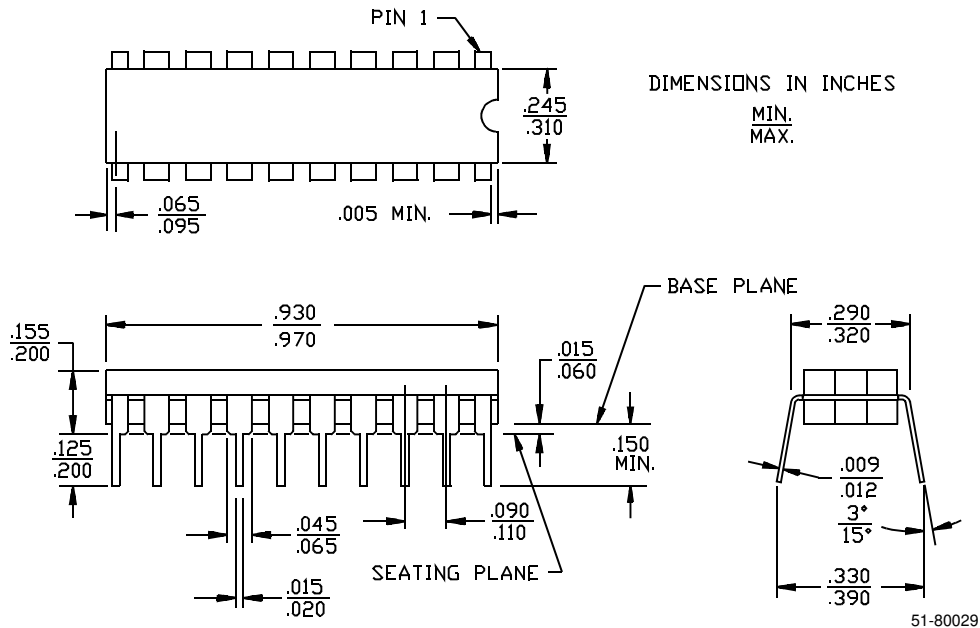
**Package Diagrams**
**20-Lead (300-Mil) CerDIP D6**  
MIL-STD-1835 D-8 Config. A

Package Diagrams (continued)

20-Lead Plastic Leaded Chip Carrier J61

DIMENSIONS IN INCHES  
MIN.  
MAX.

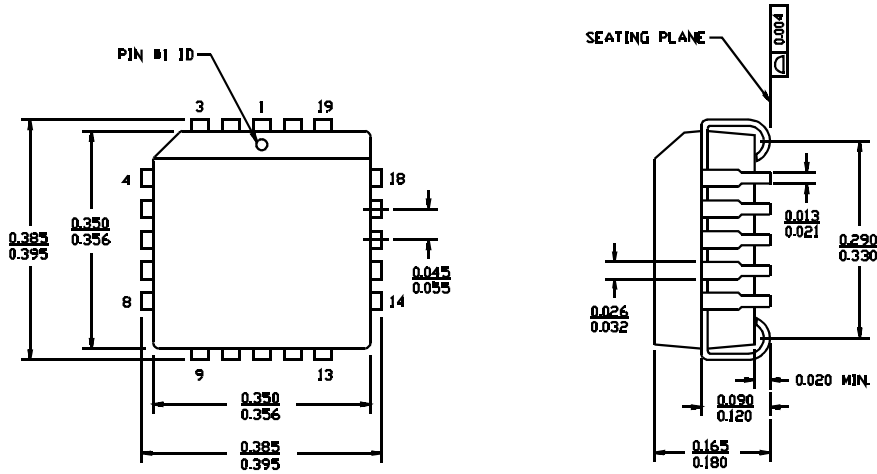

51-85000-A

20-Square Leadless Chip Carrier L61

DIMENSIONS IN INCHES

MIN.  
MAX.

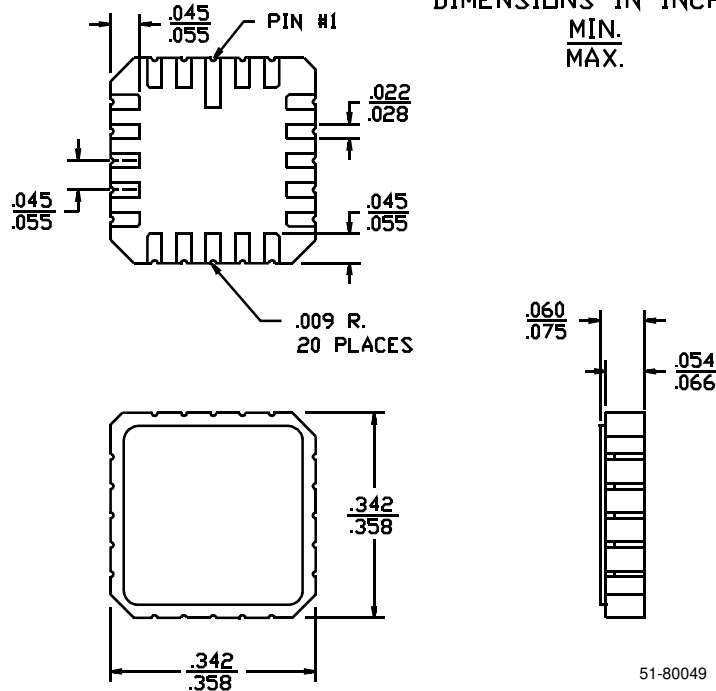

51-80049

**Package Diagrams** (continued)

**20-Lead (300-Mil) Molded DIP P5**

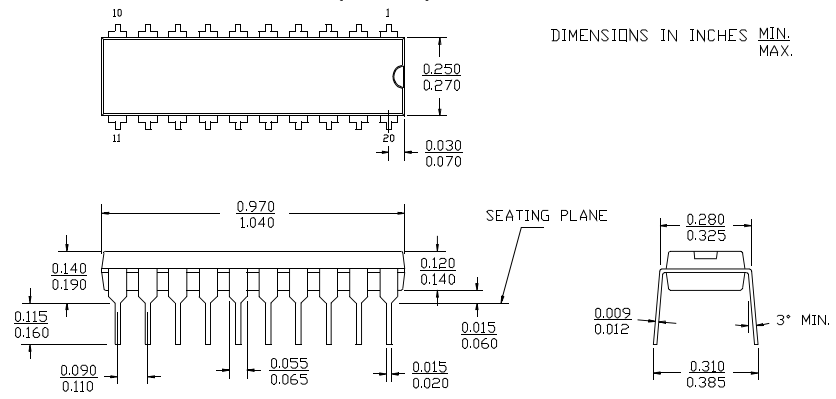

**Document Title: PALCE16V8 Flash Erasable, Reprogrammable CMOS PAL® Device**  
**Document Number: 38-03025**

<b>REV.</b>	<b>ECN NO.</b>	<b>Issue Date</b>	<b>Orig. of Change</b>	<b>Description of Change</b>
**	106370	07/11/01	SZV	Change from Spec Number: 38-00364 to 38-03025