



Chipsmall Limited consists of a professional team with an average of over 10 year of expertise in the distribution of electronic components. Based in Hongkong, we have already established firm and mutual-benefit business relationships with customers from,Europe,America and south Asia,supplying obsolete and hard-to-find components to meet their specific needs.

With the principle of “Quality Parts,Customers Priority,Honest Operation,and Considerate Service”,our business mainly focus on the distribution of electronic components. Line cards we deal with include Microchip,ALPS,ROHM,Xilinx,Pulse,ON,Everlight and Freescale. Main products comprise IC,Modules,Potentiometer,IC Socket,Relay,Connector.Our parts cover such applications as commercial,industrial, and automotives areas.

We are looking forward to setting up business relationship with you and hope to provide you with the best service and solution. Let us make a better world for our industry!



## Contact us

Tel: +86-755-8981 8866 Fax: +86-755-8427 6832

Email & Skype: info@chipsmall.com Web: www.chipsmall.com

Address: A1208, Overseas Decoration Building, #122 Zhenhua RD., Futian, Shenzhen, China



**PAM2846 EV Board User Guide**  
AE Department

**1. Revision Information**

Date	Revision	Description	Comment
2008/3/26	V2.0	Initial Release	

**2. EV Board Schematic**

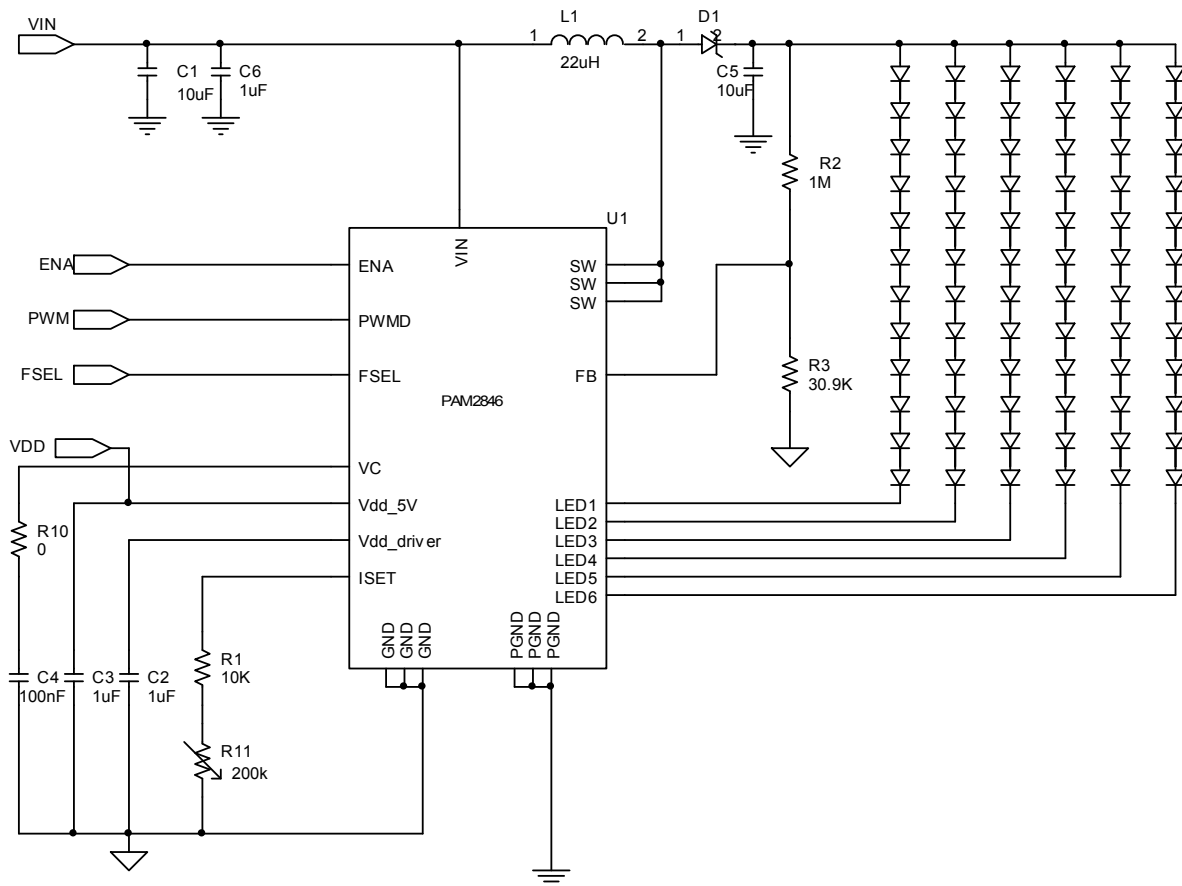



### 3. EVB PAM2846 EB7BDA Description

PAM2846 EVB7BDA is an evaluation board for the PAM2846, a six strings LED current sink.

The board is targeted to be used in providing a simple and convenient evaluation environment for the PAM2846. Analog dimming, PWM dimming, single wire dimming, current matching and efficiency etc, on the board make it easy to be evaluated.

Use single power supply (8V-24V), LED: 6-12 serial\*6 parallel, the output voltage is auto-adaptive to LED numbers.

PAM2846 EVB7BDA is working in boost and sink mode, so make sure the power supply voltage not exceed the LED voltage too much.

### 4. EV Board View

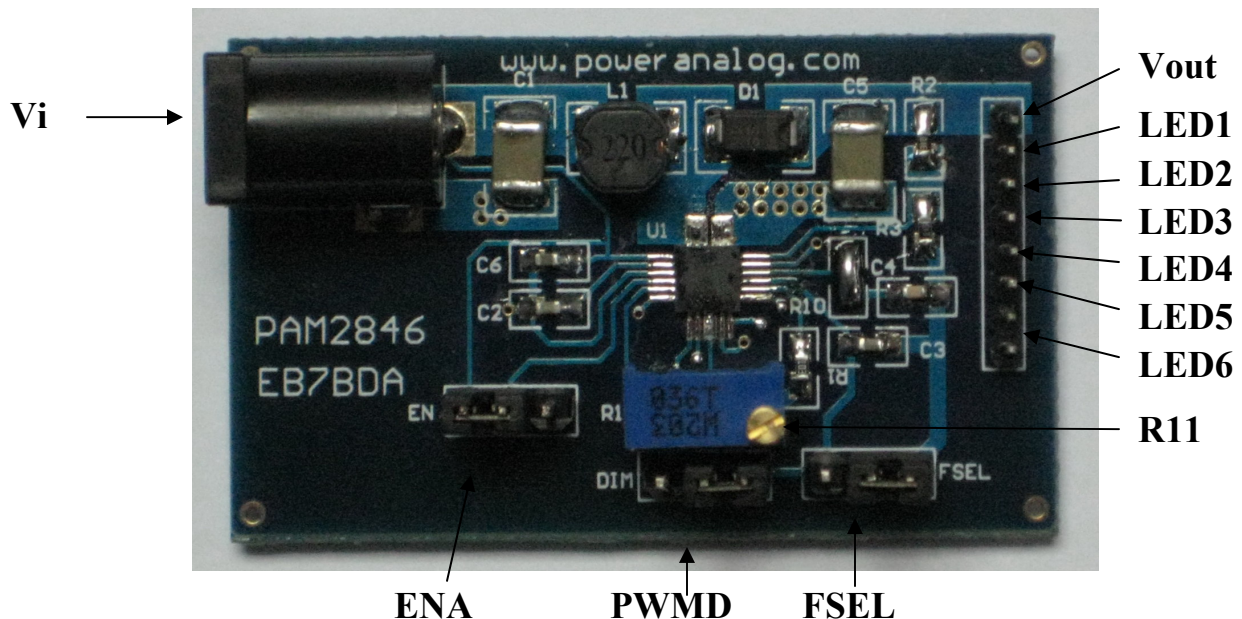

#### EV Board Operational Sequence:

##### (1) Potentiometer for LED Dimming.

- a) Connect ENA to high (Vin, left side).
- b) Connect PWMD to high (right side).
- c) Setting operating frequency. Connect FSEL to high (left side),  $f=1.6\text{MHz}$ ; connect FSEL to low (right side),  $f=500\text{kHz}$ ; FSEL NC (no connect),  $f=800\text{kHz}$ .
- d) Connect Vout to anode of all the six String's LED, their cathode connect to LED1, LED2, LED3, LED4, LED5, LED6 separately.
- e) Connect Vin to power supply.  $V_{in}=8\text{V}-24\text{V}$ .
- f) Adjust R11's value to adjust the LED's brightness.

**(2) PWM Signal Dimming Dunction.**

- a) Connect ENA to high (Vin, left side).
- b) Connect PWMD to an external PWM signal (the center pin).
- c) Setting operating frequency. Connect FSEL to high (left side), f=1.6MHz; connect FSEL to low (right side), f=500kHz; FSEL NC (no connect); f=800kHz.
- d) Connect Vout to anode of all the six String's LED, their cathode connect to LED1, LED2, LED3, LED4, LED5, LED6 separately.
- e) Connect Vin to power supply. Vin=8V-24V.
- f) Adjust external PWM signal duty cycle to adjust the LED's brightness.

**(3) Single Wire Dimming Function.**

- a) Connect ENA to external PWM signal (the center pin).
- b) Connect PWMD to high (right side).
- c) Setting operating frequency. Connect FSEL to high (left side), f=1.6MHz; connect FSEL to low (right side), f=500kHz; FSEL NC (no connect); f=800kHz.
- d) Connect Vout to anode of all the six String's LED, their cathode connect to LED1, LED2, LED3, LED4, LED5, LED6 separately.
- e) Connect Vin to power supply. Vin=8V-24V.
- f) Adjust external PWM signal to adjust the LED's brightness (see Figure-1).

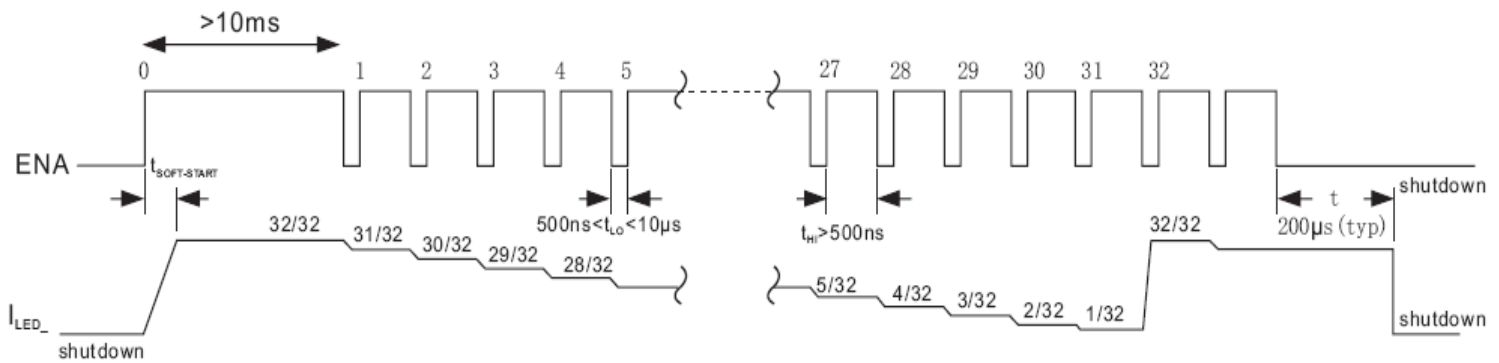

**Figure 1 ENA Timing Diagram**

## 5. EV Board BOM List

Item	Value	Type	Rating	Description	Vender and Part No.
C1, C5	10 $\mu$ F	X5R/X7R, Ceramic/1210	50V	Input coupling CAP Output CAP	Torch UDK325BJ106MM-T
C6	1.0 $\mu$ F	X5R/X7R, Ceramic/0805	25V	Vin coupling CAP	Murata GRM21BR71E105K
C2, C3	1.0 $\mu$ F	X5R/X7R, Ceramic/0805	25V	VDD_dr and VDD_5V coupling CAP	Murata GRM21BR71E105K
C4	100nF	X5R/X7R, Ceramic/0805	50V	comp CAP	Murata GRM219C0G1H104K
L1	22 $\mu$ H	1210	2A	Inductor	Sumida CDRH5D16-22R
D1		Nihon EC31QS06	3A/60V	Schottky Diode	Nihon EC31QS06
R1	10k	0603	1%	Iset Resistor	
R11	200k	potentiometer		Iset Resistor	
R2	1Meg	0805	1%	Feedback Resistor	
R3	30.9K	0603	1%	Feedback Resistor	
R10	0 $\Omega$	0603	5%	Comp Resistor	
White LED		3.2V(typ) 3.5V(max) at 20mA			

This BOM is for 12 series \* 6 parallel LED output. To optimize different numbers LED applications please see Append 1 and 2.

## 6. External Components Selection

### Input Capacitors (C1) and Output Capacitors (C5)

- (1) C1 Low ESR needed, 10 $\mu$ F, X5R/X7R ceramic recommended.
- (2) C5 Low ESR needed, 10 $\mu$ F, X5R/X7R (rating 50V) ceramic recommended.

### Coupling Capacitors (C2, C3, C6)

- (1) 1 $\mu$ F, X5R/X7R ceramic recommended.

### Iset Resistors (R1, R11)

- (1) R set all the string's LED current,  $I_{led}=228*V_{iset}/R$ ,  $R=R1+R11$ .
- (2) R1, 10K $\pm$ 1% recommend; R11, adjustable, 0-200k.

### Feedback Resistors (R2, R3)

- (1)  $V_{out}=V_{FB}*R3/(R3+R2)$ .
- (2) R2, 1Meg $\pm$ 1% recommend.
- (3)  $V_{out\_limit}$  is set in 40V, so R3 is 30.9K minimum.

### Comp Resistor (R10) and Comp Capacitor (C4)

- (1) R10, shorted.
- (2) C4, 100nF, X5R/X7R ceramic recommended.

### Inductor (L1)

- (1) Low DCR needed, 22 $\mu$ H (rating 2A) recommended

### Schottky Diode (D1)

- (1) Nihon EC31QS06(3A, 60V) recommended.
- (2) B360A (3A, 60V) recommended.

## 7. PCB Layout Guidelines

### Decoupling Capacitors

- (1) The capacitors (C6, C2, C3) need to place very close to the PAM2846's pins. The capacitor C1 need place close to the power supply.

### Grounding

- (1) The decoupling capacitors C2, C3, C4, C6 and R1, R3 should each to be grounded to analog ground (AGND).
- (2) The capacitors C1, C5 should each be grounded to power ground (PGND).
- (3) Connect the AGND and PGND islands by connecting the GND pins directly to the exposed backside pad. Make no other connections between these separate ground planes.

### Others

- (1) Connect L1, SW, D1, C5 with short and wide connections.
- (2) Place the Output voltage setting-divider resistors ( R2, R3) as close to the OV pin as possible. The divider's center trace should be kept short.
- (3) Minimize the size of the SW node while keeping it wide and short. Keep the SW node away from the feedback node and ground.
- (4) Place the Iset resistors (R1, R11) as close to the Iset pin as possible.

## 8. PCB Layout Example

Top Layer

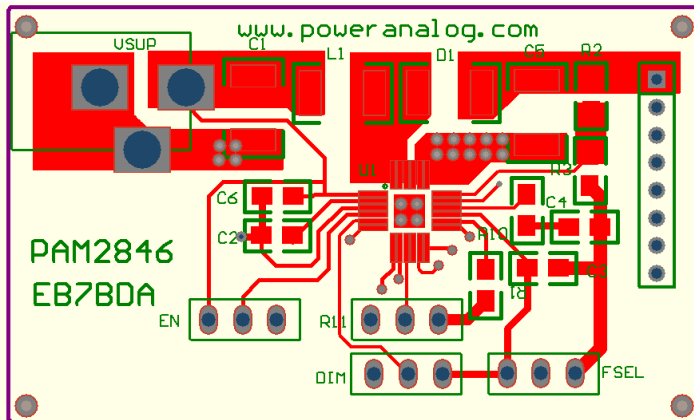

Bottom Layer

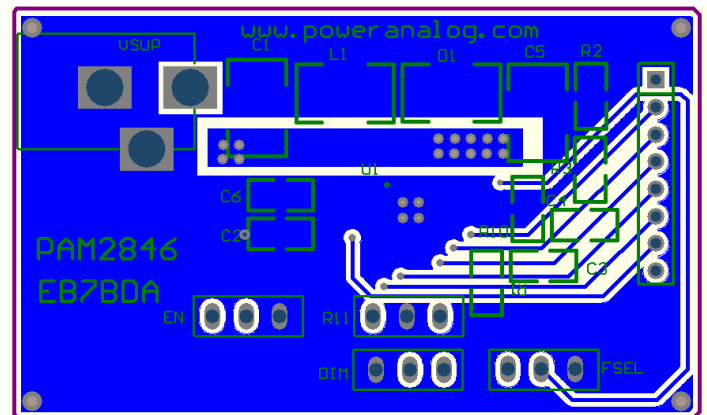

## 9. Append 1, External Component Selection table:

Circuit	Figure 3	Figure 2	Figure 2	Figure 2	Figure 3
Switching Frequency	1.6MHz	500KHz	500KHz	500KHz	800KHz
White LED	3.2V(typ), 3.5V(max) at 20mA	3.2V(typ), 3.5V(max) at 20mA	3.2V(typ), 3.5V(max) at 20mA	3.2V(typ), 3.5V(max) at 20mA	3.2V(typ), 3.5V(max) at 20mA
Number of White LEDs	6 series*6 parallel 25mA(max)	8 series*6 parallel 25mA(max)	10 series*6 parallel 25mA(max)	12 series*6 parallel 25mA(max)	6 series*6 parallel 25mA(max)
Input Voltage	4.8V to 6V, Vdd_dr=Vdd_5V=Vin or 5V (Vdd)	4.8V to 24V	8V to 28V	8V to 28V	4.8V to 6V Vdd_dr=Vdd_5V=5V (Vdd)
Inductor L1	2.2uH, 2.5A power inductor Sumida CDRH5D16-2R2	22uH, 2A power inductor Sumida CDRH5D16-220	22uH, 2A power inductor Sumida CDRH5D16-220	22uH, 2A power inductor Sumida CDRH5D16-220	4.7uH, 2.5A power inductor Sumida CDRH5D16-4R7
Input Capacitor	10uF±10%, 10V X5R Ceramic capacitor (1206) Murata GRM31MR61A106K	10uF±20%, 50V X7R ceramic capacitor(1210) Torch UDK325BJ106MM-T	10uF±20%, 50V X7R ceramic capacitor(1210) Torch UDK325BJ106MM-T	10uF±20%, 50V X7R ceramic capacitor(1210) Torch UDK325BJ106MM-T	10uF±10%, 10V X5R Ceramic capacitor (1206) Murata GRM31MR61A106K
Output Capacitor	10uF±20%, 50V X7R ceramic capacitor(1210) UDK325BJ106MM-T	10uF±20%, 50V X7R ceramic capacitor(1210) UDK325BJ106MM-T	10uF±20%, 50V X7R ceramic capacitor(1210) UDK325BJ106MM-T	10uF±20%, 50V X7R ceramic capacitor(1210) UDK325BJ106MM-T	10uF±20%, 50V X7R ceramic capacitor(1210) UDK325BJ106MM-T
Diode Rectifier	2A, 30V Schottky diode Nihon EC21QS03L	2A, 40V Schottky diode Nihon EC21QS04L	3A, 40V Schottky diode Nihon EC31QS04L	3A, 60V Schottky diode Nihon EC31QS06L	3A, 30V Schottky diode Nihon EC31QS03L
Feedback Resistors	1M±1%, 0603 60K±1%, 0603	1M±1%, 0603 45K±1%, 0603	1M±1%,0603 36K±1%,0603	1M±1%, 0603 30.9K±1%, 0603	1M±1%, 0603 60K±1%,0603
Comp capacitor	100nF±10%,50V X7R Ceramic capacitor Murata GRM188R71H104K	100nF±10%,50V X7R Ceramic capacitor Murata GRM188R71H104K	100nF±10%,50V X7R Ceramic capacitor Murata GRM188R71H104K	100nF±10%,50V X7R Ceramic capacitor Murata GRM188R71H104K	100nF±10%,50V X7R Ceramic capacitor Murata GRM188R71H104K

**Append 2, Application Circuit:**

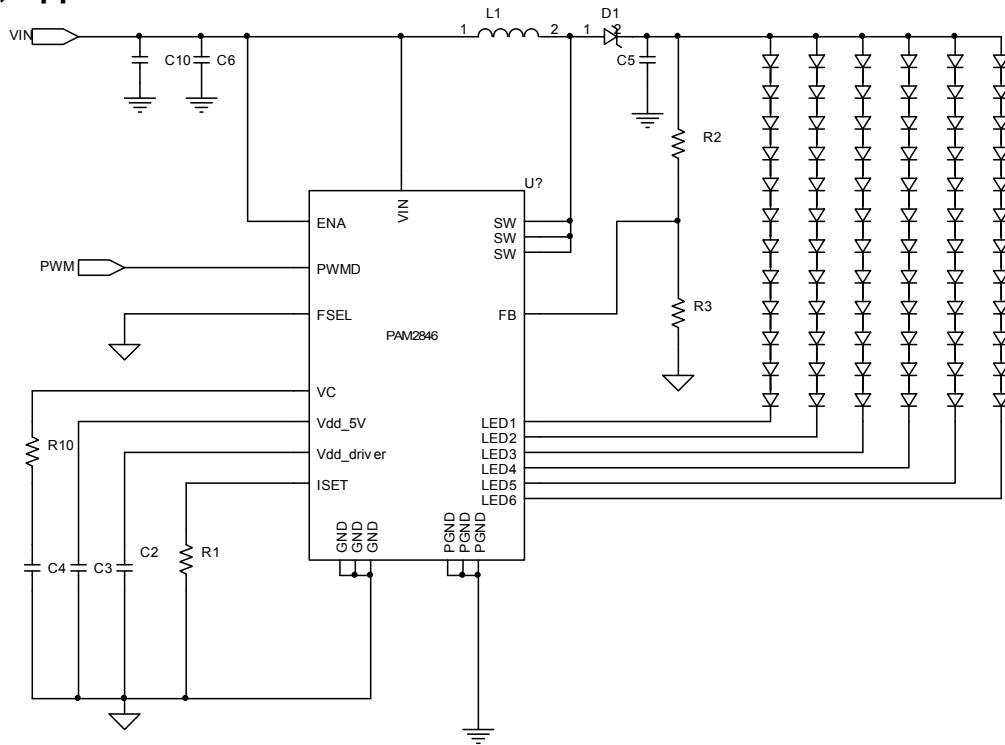

**Figure 2**

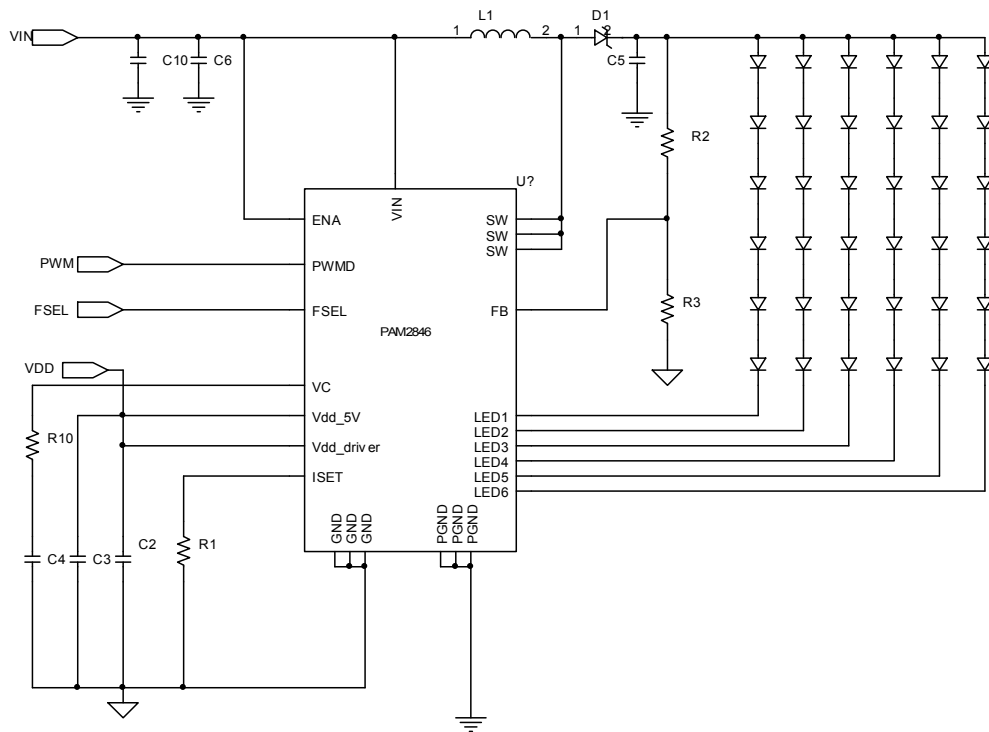

**Figure 3**