



Chipsmall Limited consists of a professional team with an average of over 10 year of expertise in the distribution of electronic components. Based in Hongkong, we have already established firm and mutual-benefit business relationships with customers from,Europe,America and south Asia,supplying obsolete and hard-to-find components to meet their specific needs.

With the principle of “Quality Parts,Customers Priority,Honest Operation,and Considerate Service”,our business mainly focus on the distribution of electronic components. Line cards we deal with include Microchip,ALPS,ROHM,Xilinx,Pulse,ON,Everlight and Freescale. Main products comprise IC,Modules,Potentiometer,IC Socket,Relay,Connector.Our parts cover such applications as commercial,industrial, and automotives areas.

We are looking forward to setting up business relationship with you and hope to provide you with the best service and solution. Let us make a better world for our industry!



Contact us

Tel: +86-755-8981 8866 Fax: +86-755-8427 6832

Email & Skype: info@chipsmall.com Web: www.chipsmall.com

Address: A1208, Overseas Decoration Building, #122 Zhenhua RD., Futian, Shenzhen, China



Description

The PAM8014 is a 3.2W mono filter-less class-D amplifier with high PSRR and differential input that eliminate noise and RF rectification. Features like greater than 90% efficiency and small PCB area make the PAM8014 Class-D amplifier ideal for portable applications. The output uses a filter-less architecture minimizing the number of external components and PCB area whilst providing a high performance, simple and lower cost system.

The PAM8014 features short circuit protection and thermal shutdown. The PAM8014 is available in U-WLB1313-9 package.

Features

- Ultra Low EMI, -20dB Better Than FCC Class-B @ 300MHz
- High Efficiency up to 93% @2W with a 8Ω Speaker
- Shutdown Current <1μA
- 3.2W@10% THD Output with a 4Ω Load at 5V Supply
- Demanding Few External Components
- Superior Low Noise without Input
- Supply Voltage from 2.5V to 5.5 V
- Short Circuit Protection
- Thermal Shutdown
- Available in Space Saving U-WLB1313-9 Package
- **Totally Lead-Free&Fully RoHS Compliant (Notes 1 & 2)**
- **Halogen and Antimony Free. "Green" Device (Note 3)**

Pin Assignments

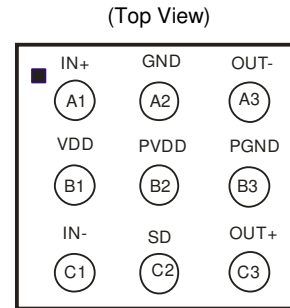

U-WLB1313-9

Applications

- Cellular Phones/Smart Phones
- MP4/MP3
- VOIP
- Digital Photo Frame
- Electronic Dictionary
- Portable Game Machines

Notes:

1. No purposely added lead. Fully EU Directive 2002/95/EC (RoHS) & 2011/65/EU (RoHS 2) compliant.
2. See http://www.diodes.com/quality/lead_free.html for more information about Diodes Incorporated's definitions of Halogen- and Antimony-free, "Green" and Lead-free.
3. Halogen- and Antimony-free "Green" products are defined as those which contain <900ppm bromine, <900ppm chlorine (<1500ppm total Br + Cl) and <1000ppm antimony compounds.

Typical Applications Circuit

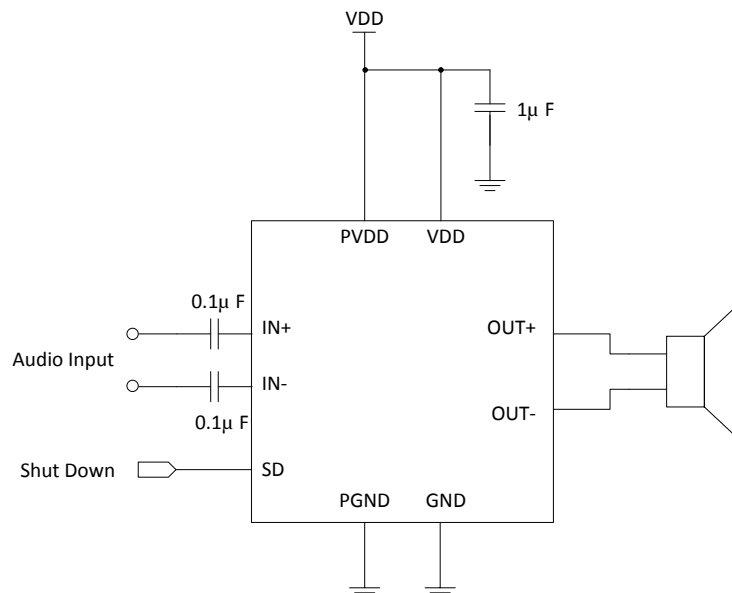

Pin Descriptions

Pin Number	Pin Name	Function
A1	IN+	Positive Differential Input
A2	GND	Ground
A3	OUT-	Negative BTL Output
B1	VDD	Power Supply
B2	PVDD	Power Supply
B3	PGND	Power Ground
C1	IN-	Negative Differential Input
C2	EN	Chip Enable
C3	OUT+	Positive BTL Output

Functional Block Diagram

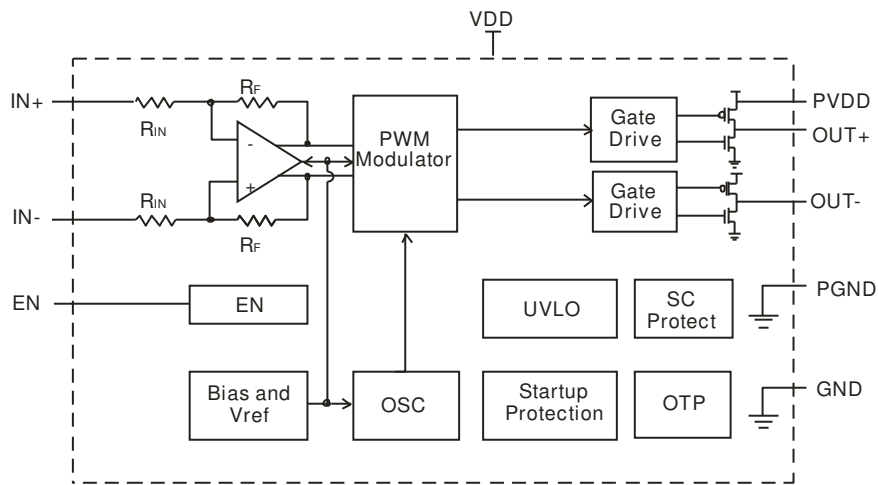

Absolute Maximum Ratings (@ $T_A = +25^\circ\text{C}$, unless otherwise specified.)

Symbol	Parameter	Value	Unit
V_{DD}	Supply Voltage (V_{DD})	6.0	V
V_I	Input Voltage (IN+, IN-, EN)	-0.3 to $V_{DD}+0.3$	V
T_S	Storage Temperature	-65 to +150	$^\circ\text{C}$
T_J	Maximum Junction Temperature	+150	$^\circ\text{C}$

Recommended Operating Conditions (@ $T_A = +25^\circ\text{C}$, unless otherwise specified.)

Symbol	Parameter	Min	Max	Unit
V_{DD}	Supply Voltage	2.5	5.5	V
T_A	Operating Ambient Temperature Range	-25	+85	$^\circ\text{C}$
T_J	Junction Temperature	-40	+125	$^\circ\text{C}$

Electrical Characteristics (@ $T_A = +25^\circ\text{C}$, $V_{DD} = 5\text{V}$, $R_{IN} = 0$, Gain=18dB, $R_L = L(33\mu\text{H})+R+L(33\mu\text{H})$, unless otherwise specified.)

Symbol	Parameter	Test Conditions	Min	Typ	Max	Unit	
V_{DD}	Supply Voltage	—	2.5	—	5.5	V	
P_O	Output Power	THD+N = 10%, f = 1kHz, R = 4 Ω	$V_{DD} = 5.0\text{V}$	—	3.2	—	W
			$V_{DD} = 3.6\text{V}$	—	1.6	—	
		THD+N = 1%, f = 1kHz, R = 4 Ω	$V_{DD} = 5.0\text{V}$	—	2.45	—	W
			$V_{DD} = 3.6\text{V}$	—	1.3	—	
		THD+N = 10%, f = 1kHz, R = 8 Ω	$V_{DD} = 5.0\text{V}$	—	1.8	—	W
			$V_{DD} = 3.6\text{V}$	—	0.95	—	
		THD+N = 1%, f = 1kHz, R = 8 Ω	$V_{DD} = 5.0\text{V}$	—	1.40	—	W
			$V_{DD} = 3.6\text{V}$	—	0.72	—	
THD+N	Total Harmonic Distortion Plus Noise	$V_{DD} = 5.0\text{V}$, $P_O = 1\text{W}$, R = 8 Ω	f = 1kHz	—	0.17	—	%
				$V_{DD} = 3.6\text{V}$, $P_O = 0.1\text{W}$, R = 8 Ω	—	0.16	
		$V_{DD} = 5.0\text{V}$, $P_O = 0.5\text{W}$, R = 4 Ω	f = 1kHz	—	0.14	—	%
				$V_{DD} = 3.6\text{V}$, $P_O = 0.2\text{W}$, R = 4 Ω	—	0.16	
PSRR	Power Supply Ripple Rejection	$V_{DD} = 3.6\text{V}$, Input AC-ground with C = 1 μF	f = 217Hz	—	-75	—	dB
			f = 1kHz	—	-75	—	
Dyn	Dynamic Range	$V_{DD} = 5\text{V}$, THD = 1%, R = 8 Ω	f = 1kHz	—	95	—	dB
V_N	Output Noise	Input AC-ground	No A weighting	—	60	—	μV
			A-weighting	—	40	—	
η	Efficiency	$R_L = 8\Omega$, THD = 10%	f = 1kHz	—	93	—	%
		$R_L = 4\Omega$, THD = 10%		—	86	—	
I_Q	Quiescent Current	$V_{DD} = 5\text{V}$	No Load	—	4	—	mA
I_{SD}	Shutdown Current	$V_{DD} = 2.5\text{V}$ to 5V	$S_D = 0\text{V}$	—	—	1	μA
$R_{DS(ON)}$	Static Drain-to-Source On-State Resistor	High Side PMOS, I = 500mA	$V_{DD} = 5.0\text{V}$	—	200	—	$\text{m}\Omega$
		Low Side NMOS, I = 500mA	$V_{DD} = 5.0\text{V}$	—	200	—	$\text{m}\Omega$
f_{SW}	Switching Frequency	$V_{DD} = 2.5\text{V}$ to 5.5V	—	—	250	—	kHz
G_V	Closed-Loop Gain	$V_{DD} = 2.5\text{V}$ to 5.5V	—	—	8	—	V/V
R_{IN}	Input Impedance (In Chip)	$V_{DD} = 2.5\text{V}$ to 5.5V	—	—	31	—	K Ω
t_{ON}	Turn-on Time	$V_{DD} = 2.5\text{V}$ to 5.5V	—	—	32	—	ms
OTP	Over Temperature Protection	$V_{DD} = 2.5\text{V}$ to 5.5V	—	—	+150	—	$^\circ\text{C}$
OTH	Over Temperature Hysteresis	$V_{DD} = 2.5\text{V}$ to 5.5V	—	—	+40	—	
V_{OS}	Output Offset Voltage	Input AC-ground, $V_{DD} = 5\text{V}$	—	—	—	20	mV
V_{IH}	EN Input High Voltage	$V_{DD} = 5\text{V}$	—	1.4	—	—	V
V_{IL}	EN Input Low Voltage	$V_{DD} = 5\text{V}$	—	—	—	1.0	

Performance Characteristics (@ $T_A = +25^\circ\text{C}$, $V_{DD} = 5\text{V}$, $R_{IN} = 0$, Gain = 18dB, $R_L = L(33\mu\text{H})+R+L(33\mu\text{H})$, unless otherwise specified.)

THD+N vs. Output Power ($V_{DD}=5\text{V}$, $R_L=4\Omega$)

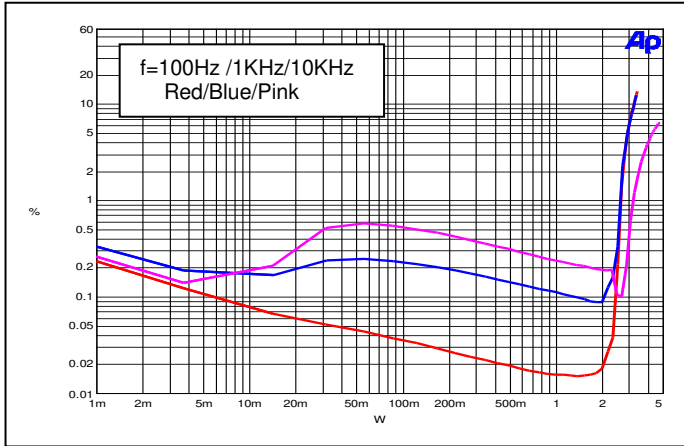

THD+N vs. Output Power ($V_{DD}=5\text{V}$, $R_L=8\Omega$)

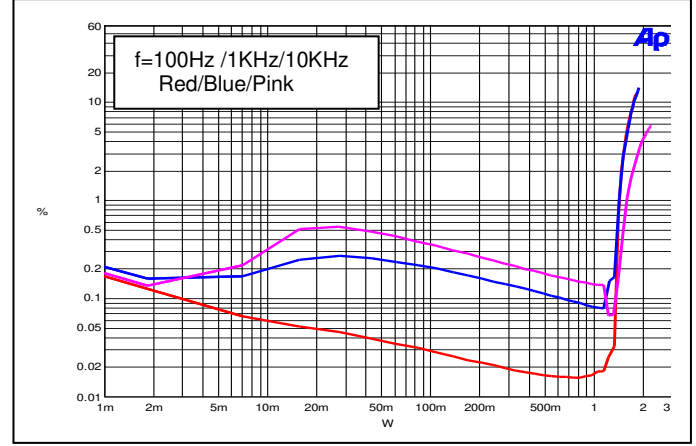

THD+N vs. Output Power ($V_{DD}=3.6\text{V}$, $R_L=4\Omega$)

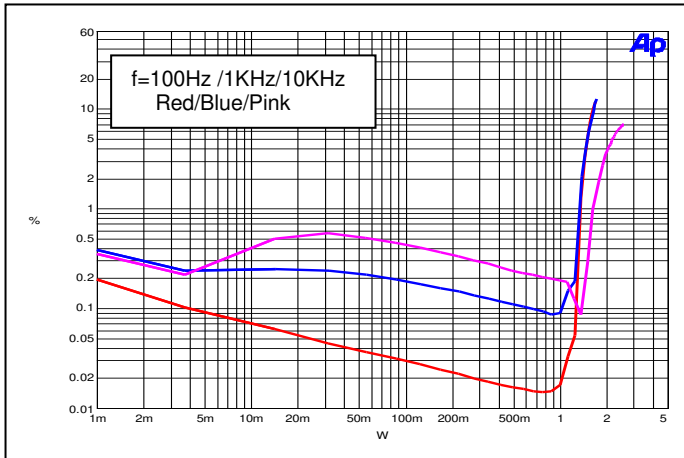

THD+N vs. Output Power ($V_{DD}=3.6\text{V}$, $R_L=8\Omega$)

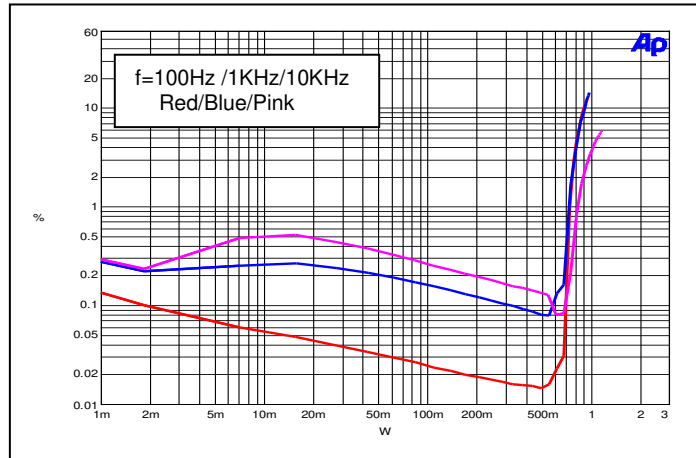

THD+N vs. Frequency ($V_{DD}=5.0\text{V}$, $R_L=4\Omega$)

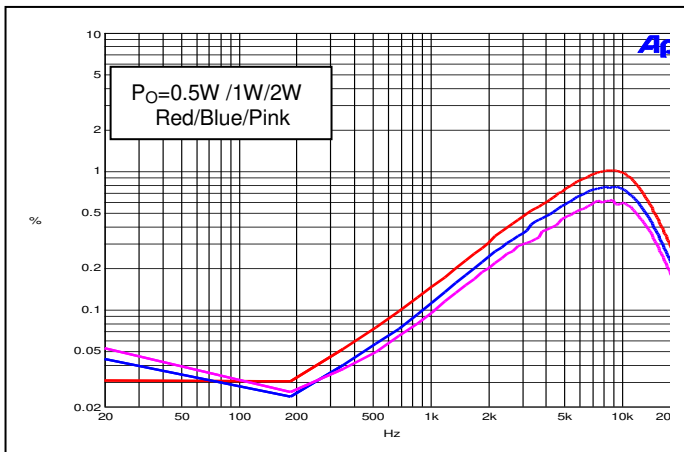

THD+N vs. Frequency ($V_{DD}=5.0\text{V}$, $R_L=8\Omega$)

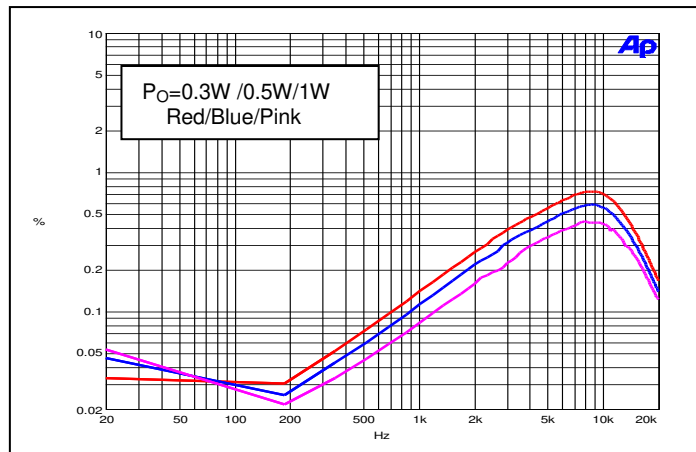

Performance Characteristics (@ $T_A = +25^\circ\text{C}$, $V_{DD} = 5\text{V}$, $R_{IN} = 0$, Gain = 18dB, $R_L = L(33\mu\text{H})+R+L(33\mu\text{H})$, unless otherwise specified.)

PSRR vs. Frequency ($V_{DD}=5.0\text{V}$, $R_L=4\Omega$)

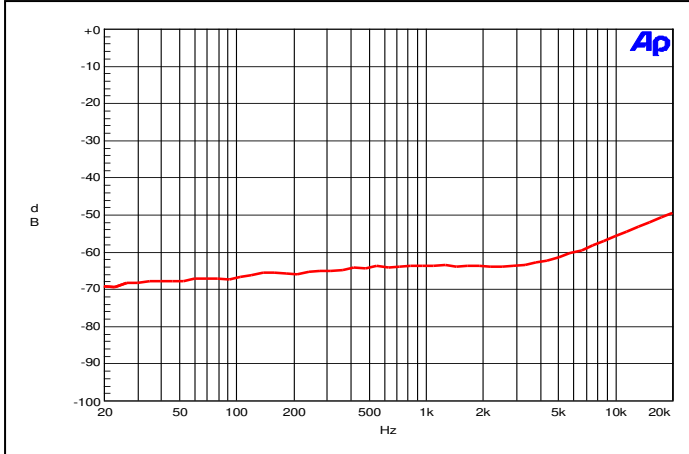

PSRR vs. Frequency ($V_{DD}=5.0\text{V}$, $R_L=8\Omega$)

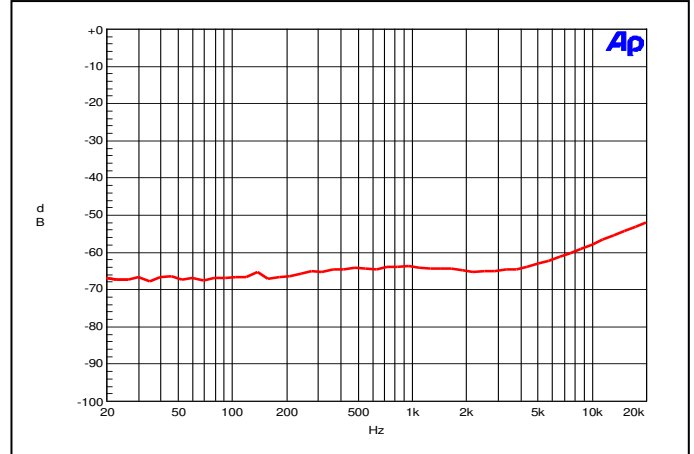

Frequency Response

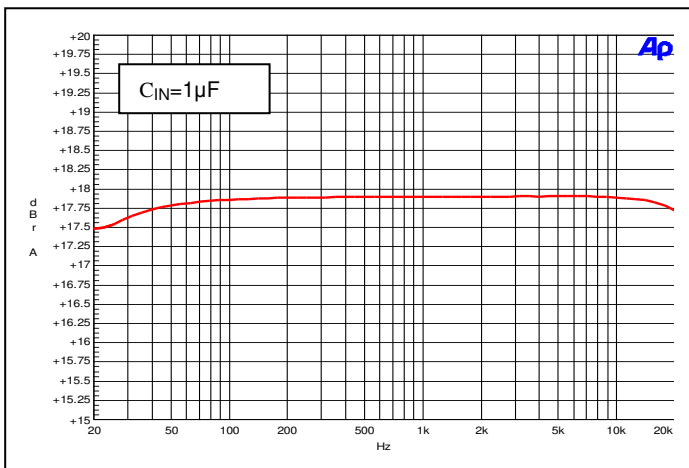

Noise Floor

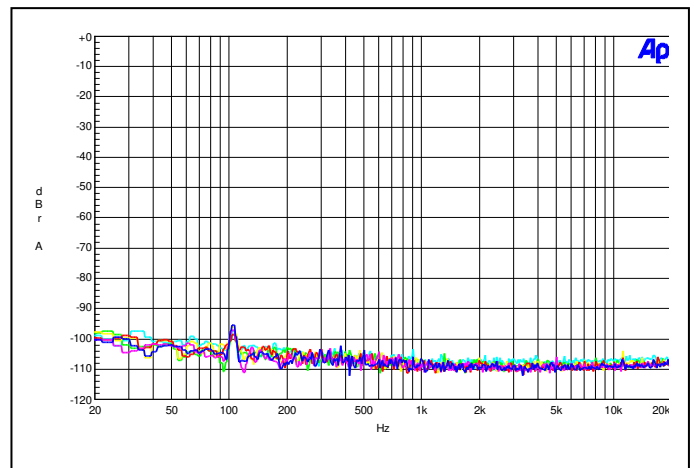

Efficiency vs. Output Power ($V_{DD}=5.0\text{V}$, $R_L=4\Omega$)

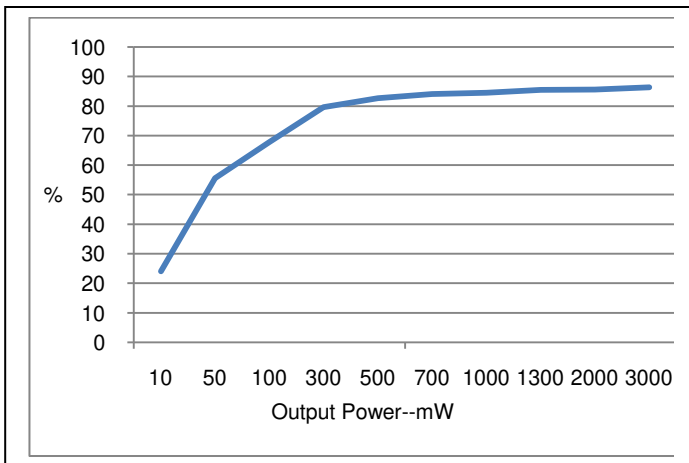

Efficiency vs. Output Power ($V_{DD}=5.0\text{V}$, $R_L=8\Omega$)

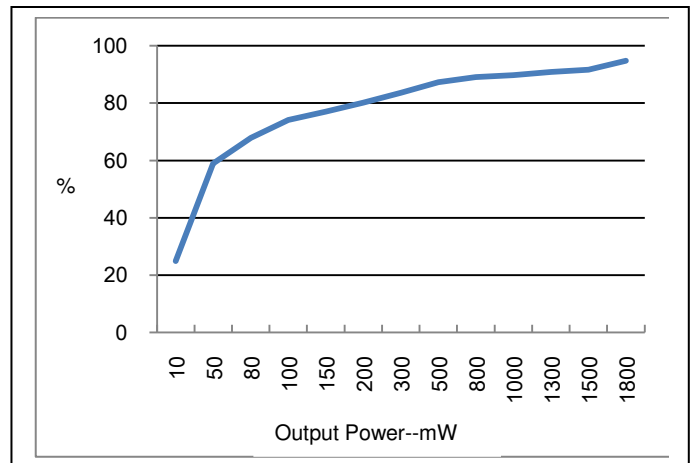

Application Information

Close Loop Gain (G_V)

The close loop gain is set by the ratio of the input resistance R_{IN} and feedback resistance R_F (refer to block diagram), and the close loop gain equation is as follow:

$$G_V = 2 * \left(\frac{R_F}{R_{IN}} \right)$$

Which R_F is set at 124K Ω and R_{IN} is 31K Ω , the G_V default is 8V/V, which is 18dB.

Input Capacitors (C_{IN})

In the typical application, an input capacitor, C_{IN} , is required to allow the amplifier to bias the input signal to the proper DC level for optimum operation. In this case, C_{IN} and the input impedance R_{IN} form a high-pass filter with the corner frequency determined in the follow equation:

$$f_c = \left(\frac{1}{2\pi R_{IN} C_{IN}} \right)$$

It is important to consider the value of C_{IN} as it directly affects the low frequency performance of the circuit. For example, when R_{IN} is 31k Ω and the specification calls for a flat bass response are down to 150Hz. Equation is reconfigured as followed:

$$C_{IN} = \left(\frac{1}{2\pi R_{IN} f_c} \right)$$

When input resistance variation is considered, the C_{IN} is 7nF, so one would likely choose a value of 10nF. A further consideration for this capacitor is the leakage path from the input source through the input network C_{IN} , R_{IN} and feedback resistor R_F to the load. This leakage current creates a DC offset voltage at the input to the amplifier that reduces useful headroom, especially in high gain applications. For this reason, a low-leakage tantalum or ceramic capacitor is the best choice. When polarized capacitors are used, the positive side of the capacitor should face the amplifier input in most applications as the DC level is held at $V_{DD}/2$, which is likely higher than the source DC level. Please note that it is important to confirm the capacitor polarity in the application.

Decoupling Capacitor (CS)

The PAM8014 is a high-performance CMOS audio amplifier that requires adequate power supply decoupling to ensure the output total harmonic distortion (THD) as low as possible. Power supply decoupling also prevents the oscillations causing by long lead length between the amplifier and the speaker.

The optimum decoupling is achieved by using two different types of capacitors that target on different types of noise on the power supply leads. For higher frequency transients, spikes, or digital hash on the line, a good low equivalent-series-resistance (ESR) ceramic capacitor, typically 1 μ F, is placed as close as possible to the device V_{DD} pin for the best operation. For filtering lower frequency noise signals, a large ceramic capacitor of 10 μ F or greater placed near the audio power amplifier is recommended.

How to Reduce EMI

Most applications require a ferrite bead filter for EMI elimination shown at Figure 1. The ferrite filter reduces EMI around 1MHz and higher. When selecting a ferrite bead, choose one with high impedance at high frequencies, but low impedance at low frequencies.

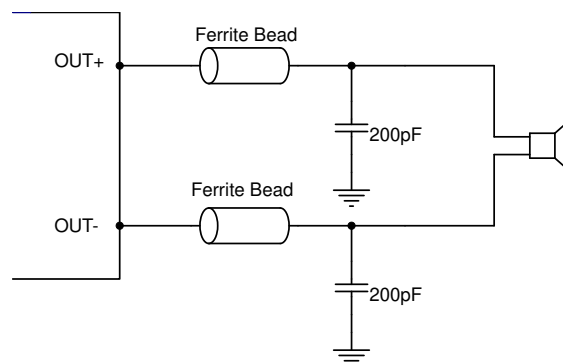

Figure 1. Ferrite Bead Filter to Reduce EMI

Application Information (Cont.)

Shutdown Operation

In order to reduce power consumption while not in use, the PAM8014 contains shutdown circuitry amplifier off when logic low is placed on the EN pin. By switching the shutdown pin connected to GND, the PAM8014 supply current draw will be minimized in idle mode.

Under Voltage Lock-out (UVLO)

The PAM8014 incorporates circuitry designed to detect low supply voltage. When the supply voltage drops to 2.0V or below, the PAM8014 goes into a state of shutdown, and the device comes out of its shutdown state and restore to normal function only when V_{DD} higher than 2.2V.

Short Circuit Protection (SCP)

The PAM8014 has short circuit protection circuitry on the outputs to prevent the device from damage when output-to-output shorts or output-to-GND shorts occur. When a short circuit occurs, the device immediately goes into shutdown state. Once the short is removed, the device will be reactivated.

Over Temperature Protection (OTP)

Thermal protection on the PAM8014 prevents the device from damage when the internal die temperature exceeds +150°C. There is a +15°C tolerance on this trip point from device to device. Once the die temperature exceeds the set point, the device will enter the shutdown state and the outputs are disabled. This is not a latched fault. The thermal fault is cleared once the temperature of the die decreased by +40°C. This large hysteresis will prevent motor boating sound well and the device begins normal operation at this point with no external system interaction.

POP and Click Circuitry

The PAM8014 contains circuitry to minimize turn-on and turn-off transients or “click and pops”, where turn-on refers to either power supply turn-on or device recover from shutdown mode. When the device is turned on, the amplifiers are internally muted. An internal current source ramps up the internal reference voltage. The device will remain in mute mode until the reference voltage reach half supply voltage, $1/2 V_{DD}$. As soon as the reference voltage is stable, the device will begin full operation. For the best power-off pop performance, the amplifier should be set in shutdown mode prior to removing the power supply voltage.

Ordering Information (Note 4)

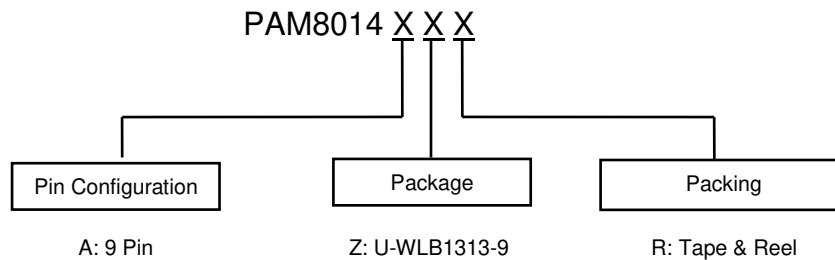

Part Number	Package	7" Tape and Reel	
		Quantity	Part Number Suffix
PAM8014AZR	U-WLB1313-9	3000/Tape & Reel	-7

Note: 4. For packaging details, go to our website at <http://www.diodes.com/products/packages.html>.

Marking Information

PAM8014- U-WLB1313-9

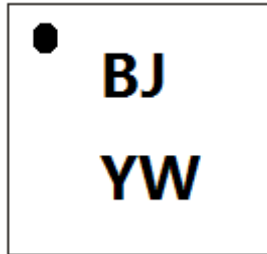

BJ: Product Code
Y: Year 0~9
W: Week: A~Z: 1~26 weeks;
a~z: 27~52 weeks; z
represents 52 and 53
weeks.

Package Outline Dimensions

Please see AP02001 at http://www.diodes.com/_files/datasheets/ap02001.pdf for the latest version.

U-WLB1313-9

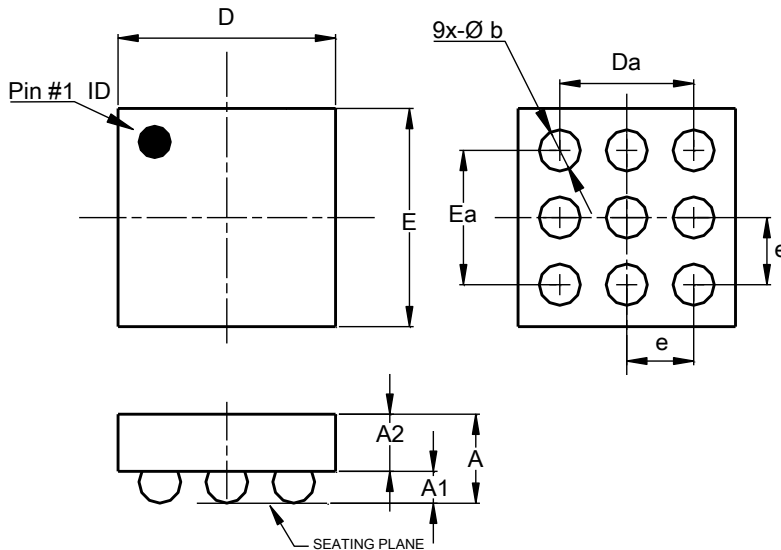

U-WLB1313-9			
Dim	Min	Max	Typ
A	0.500	0.600	0.550
A1	0.185	0.235	0.210
A2	0.315	0.365	0.340
b	0.208	0.308	0.258
D	1.240	--	--
Da	0.750	0.850	0.800
E	1.240	--	--
Ea	0.750	0.850	0.800
e	0.400 BSC		
All Dimensions in mm			

Suggested Pad Layout

Please see AP02001 at http://www.diodes.com/_files/datasheets/ap02001.pdf for the latest version.

U-WLB1313-9

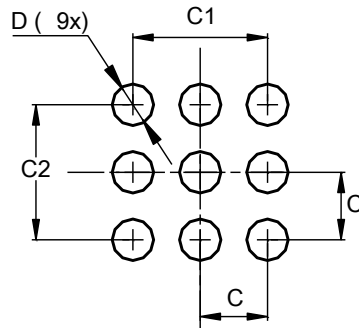

Dimensions	Value (in mm)
C	0.400
C1	0.800
C2	0.800
D	0.258

IMPORTANT NOTICE

DIODES INCORPORATED MAKES NO WARRANTY OF ANY KIND, EXPRESS OR IMPLIED, WITH REGARDS TO THIS DOCUMENT, INCLUDING, BUT NOT LIMITED TO, THE IMPLIED WARRANTIES OF MERCHANTABILITY AND FITNESS FOR A PARTICULAR PURPOSE (AND THEIR EQUIVALENTS UNDER THE LAWS OF ANY JURISDICTION).

Diodes Incorporated and its subsidiaries reserve the right to make modifications, enhancements, improvements, corrections or other changes without further notice to this document and any product described herein. Diodes Incorporated does not assume any liability arising out of the application or use of this document or any product described herein; neither does Diodes Incorporated convey any license under its patent or trademark rights, nor the rights of others. Any Customer or user of this document or products described herein in such applications shall assume all risks of such use and will agree to hold Diodes Incorporated and all the companies whose products are represented on Diodes Incorporated website, harmless against all damages.

Diodes Incorporated does not warrant or accept any liability whatsoever in respect of any products purchased through unauthorized sales channel. Should Customers purchase or use Diodes Incorporated products for any unintended or unauthorized application, Customers shall indemnify and hold Diodes Incorporated and its representatives harmless against all claims, damages, expenses, and attorney fees arising out of, directly or indirectly, any claim of personal injury or death associated with such unintended or unauthorized application.

Products described herein may be covered by one or more United States, international or foreign patents pending. Product names and markings noted herein may also be covered by one or more United States, international or foreign trademarks.

This document is written in English but may be translated into multiple languages for reference. Only the English version of this document is the final and determinative format released by Diodes Incorporated.

LIFE SUPPORT

Diodes Incorporated products are specifically not authorized for use as critical components in life support devices or systems without the express written approval of the Chief Executive Officer of Diodes Incorporated. As used herein:

A. Life support devices or systems are devices or systems which:

1. are intended to implant into the body, or
2. support or sustain life and whose failure to perform when properly used in accordance with instructions for use provided in the labeling can be reasonably expected to result in significant injury to the user.

B. A critical component is any component in a life support device or system whose failure to perform can be reasonably expected to cause the failure of the life support device or to affect its safety or effectiveness.

Customers represent that they have all necessary expertise in the safety and regulatory ramifications of their life support devices or systems, and acknowledge and agree that they are solely responsible for all legal, regulatory and safety-related requirements concerning their products and any use of Diodes Incorporated products in such safety-critical, life support devices or systems, notwithstanding any devices- or systems-related information or support that may be provided by Diodes Incorporated. Further, Customers must fully indemnify Diodes Incorporated and its representatives against any damages arising out of the use of Diodes Incorporated products in such safety-critical, life support devices or systems.

Copyright © 2016 Diodes Incorporated

www.diodes.com