



Chipsmall Limited consists of a professional team with an average of over 10 year of expertise in the distribution of electronic components. Based in Hongkong, we have already established firm and mutual-benefit business relationships with customers from,Europe,America and south Asia,supplying obsolete and hard-to-find components to meet their specific needs.

With the principle of "Quality Parts,Customers Priority,Honest Operation,and Considerate Service",our business mainly focus on the distribution of electronic components. Line cards we deal with include Microchip,ALPS,ROHM,Xilinx,Pulse,ON,Everlight and Freescale. Main products comprise IC,Modules,Potentiometer,IC Socket,Relay,Connector.Our parts cover such applications as commercial,industrial, and automotives areas.

We are looking forward to setting up business relationship with you and hope to provide you with the best service and solution. Let us make a better world for our industry!



Contact us

Tel: +86-755-8981 8866 Fax: +86-755-8427 6832

Email & Skype: info@chipsmall.com Web: www.chipsmall.com

Address: A1208, Overseas Decoration Building, #122 Zhenhua RD., Futian, Shenzhen, China



Description

The PAM8100 is a 3-VRMS pop-free stereo line driver designed to allow the removal of the output DC-blocking capacitors for reduced component count and cost. The device is ideal for single-supply electronics where size and cost are critical design parameters.

The PAM8100 is capable of driving 3Vrms into a 2.5-kΩ load with 5-V supply voltage. The device has differential inputs and uses external gain-setting resistors to support a gain range of ±1 V/V to ±10 V/V. The PAM8100 has built-in mute control for pop-free on/off control. The PAM8100 has an external and internal undervoltage detector that mutes the output.

Using the PAM8100 in audio products can reduce component count considerably compared to traditional methods of generating a 3-Vrms output.

The PAM8100 is available in a 14-pin TSSOP.

Features

- Eliminates Pop/Clicks
 - Eliminates Output DC-Blocking Capacitors
 - Provides Flat Frequency Response 20Hz-20kHz
- Low Noise and THD
 - SNR > 105 dB
 - Typical Vn < 13uVrms
 - THD+N < 0.005%
- Output Voltage Into 2.5-kΩ Load
 - 2 Vrms With 3.3V Supply Voltage
 - 3 Vrms With 5V Supply Voltage
- Differential Input
 - External Undervoltage Mute
- **Lead-Free Finish; RoHS Compliant (Notes 1 & 2)**
- **Halogen and Antimony Free. "Green" Device (Note 3)**

Pin Assignments

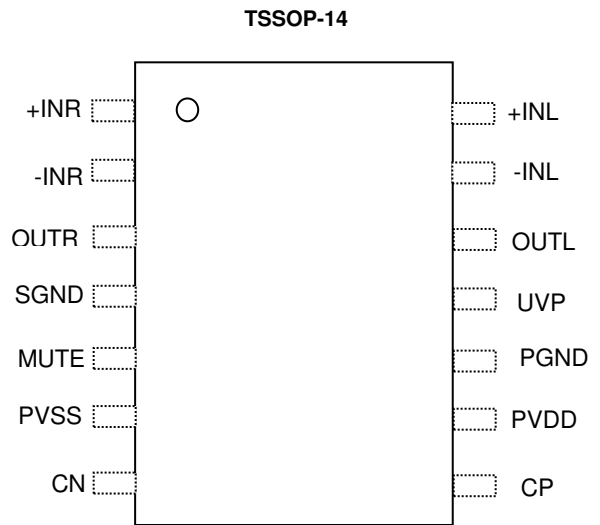

Applications

- PDP / LCD TVs
- Blu-ray Disc™, DVD Players
- Home Theater in a Box
- Set-Top Boxes

Typical Applications Circuit

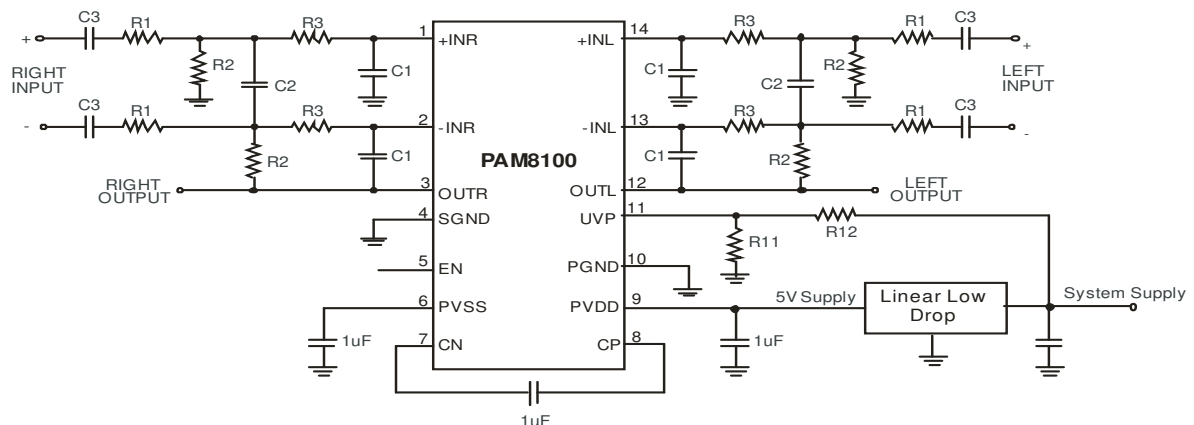

- Notes:
1. EU Directive 2002/95/EC (RoHS) & 2011/65/EU (RoHS 2) compliant. All applicable RoHS exemptions applied.
 2. See http://www.diodes.com/quality/lead_free.html for more information about Diodes Incorporated's definitions of Halogen- and Antimony-free, "Green" and Lead-free.
 3. Halogen- and Antimony-free "Green" products are defined as those which contain <900ppm bromine, <900ppm chlorine (<1500ppm total Br + Cl) and <1000ppm antimony compounds.

Pin Descriptions

Pin Number	Name	I/O	Description
1	+INR	I	Right-channel OPAMP positive input
2	-INR	I	Right-channel OPAMP negative input
3	OUTR	O	Right-channel OPAMP output
4	SGND	P	Signal ground
5	MUTE	I	Mute, active-high
6	PVSS	P	Supply voltage
7	CN	I/O	Charge-pump flying capacitor negative terminal
8	CP	I/O	Charge-pump flying capacitor positive terminal
9	PVDD	P	Positive supply
10	PGND	P	Power ground
11	UVP	I	Under voltage protection input
12	OUTL	O	Left-channel OPAMP output
13	-INL	I	Left-channel OPAMP negative input
14	+INL	I	Left-channel OPAMP positive input

Absolute Maximum Ratings (@T_A = +25°C, unless otherwise specified.)

Symbol	Description	VALUE	UNIT
V _{DD}	Supply Voltage	-0.3 to 6.0	V
V _I	Input Pins	GND-0.3 to VDD + 0.3	V
T _A	Operating Free-Air Temperature Range	-40 to +85	°C
T _J	Operating Junction Temperature Range	-40 to +150	°C
T _{STG}	Storage Temperature Range	-65 to +150	°C

Recommended Operating Conditions (@T_A = +25°C, unless otherwise specified.)

Symbol	Parameter	Min	Nom	Max	Unit
V _{IN}	Supply Voltage	2.5	-	5	V
R _L	Load Impedance	0.6	10	-	kΩ
V _{IH}	High-Level Input Voltage	1.2	-	V _{IN}	V
V _{IL}	Low-Level Input Voltage	-0.3	-	0.4	V
T _A	Operating Free-Air Temperature	-40	25	+85	°C

Thermal Information

Parameter	Symbol	Package	Maximum	Unit
Thermal Resistance (Junction to Ambient)	θ _{JA}	TSSOP-14	35	°C/W
Thermal Resistance (Junction to Case)	θ _{JC}	TSSOP-14	14	°C/W

Electrical Characteristics (@VDD=3.3V, TA=+25°C, RL=10kΩ, C(PUMP)=C(PVSS) =1μF, CIN=2.2μF, RIN=15kΩ, Rfb=30kΩ, Unless otherwise specified.)

PARAMETER	Symbol	Conditions	Min	Typ	Max	Units
Output Offset Voltage	V _{OS}	No load	-	-	3	mV
Power-Supply Rejection Ratio	P _{SRR}	Input AC-GND, f=1kHz, V _{pp} =200mV	-	70	-	dB
High-Level Output Voltage	V _{OH}	VDD=3.3V	3.1	-	-	V
Low-Level Output Voltage	V _{OL}	VDD=3.3V	-	-	-3.05	V
MUTE High	V _{IH}	VDD=3.3V	1.5	-	-	V
MUTE Low	V _{IL}	VDD=3.3V	-	-	0.4	V
Supply Current	I _{DD}	No load, MUTE=VDD	-	10	-	mA
		No load, MUTE=GND	-	10	-	mA
Output Voltage (outputs in phase)	V _o	THD=1%, VDD=3.3V, f=1kHz	2.0	2.4	-	V _{rms}
Total Harmonic Distortion Plus Noise	THD+N	V _O =2V _{rms} , f=1kHz	-	0.0015	-	%
Crosstalk	CS	V _O =1V _{rms} , f=1kHz	-	-110	-	dB
Maximum Capacitive Load	MCL	-	-	470	-	pF
Noise Output Voltage	V _N	Input AC-GND, A-weighted	-	13	-	uV _{rms}
Signal-to-Noise Ratio	SNR	V _O =2V _{rms} , A-weighted	-	104	-	dB
External UnderVoltage Detection	V _{UVP}	-	-	1.25	-	V
External Under-Voltage Detection Hysteresis Current	I _{HYSI}	-	-	5	-	μA
Charge Pump Frequency	f _{CP}	-	200	300	400	kHz

Performance Characteristics (@ $T_A=+25^\circ\text{C}$, $V_{DD}=3.3\text{V}$, $C(\text{PUMP})=C(\text{PVSS})=1\mu\text{F}$, $C_{IN}=2.2\mu\text{F}$, $R_{IN}=15\text{ k}\Omega$, $R_{fb}=30\text{ k}\Omega$, unless otherwise specified.)

THD+N vs. Output Voltage (RL=10k Ω)

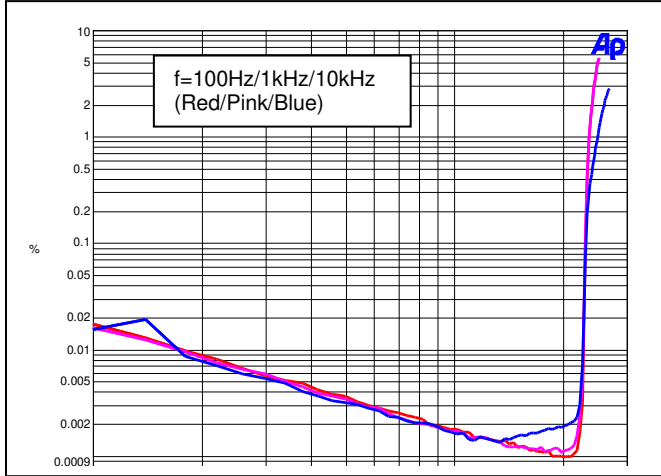

THD+N vs. Output Voltage (RL=600 Ω)

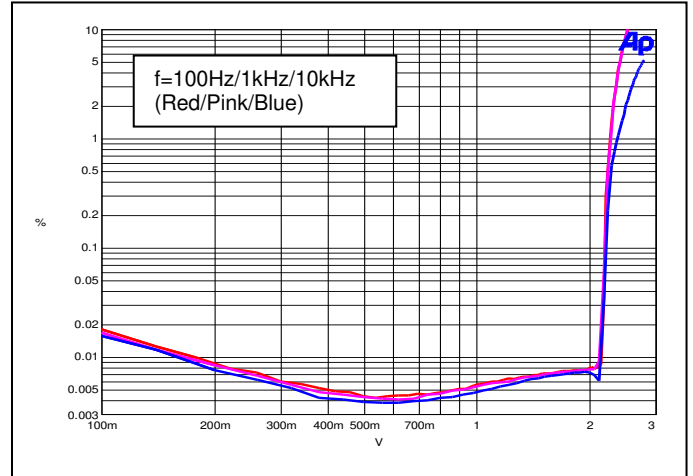

THD+N vs. Frequency (RL=10k Ω)

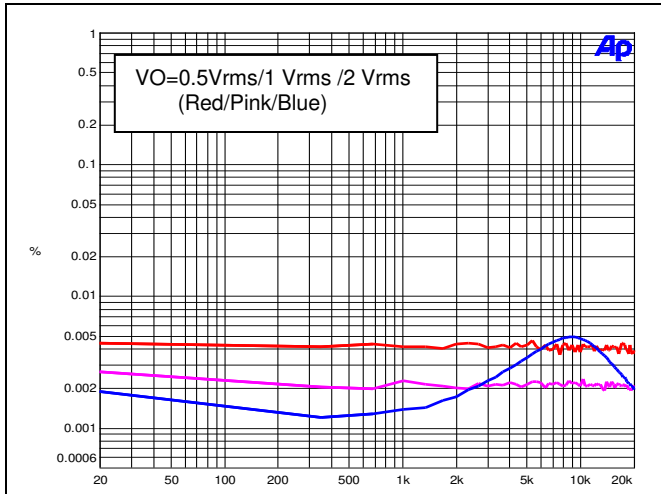

THD+N vs. Frequency (RL=600 Ω)

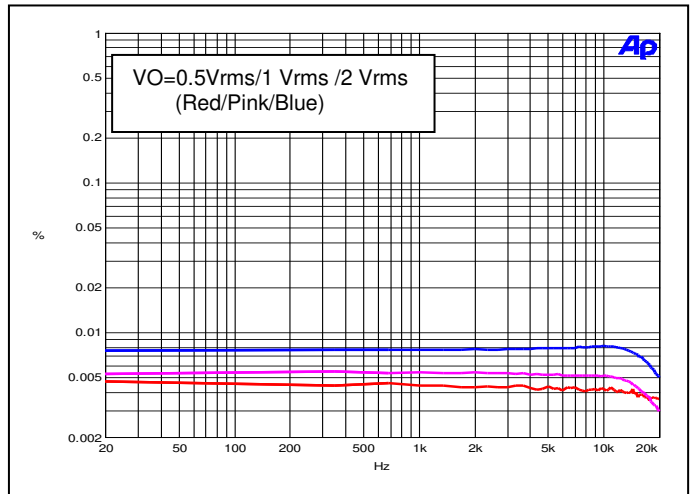

Crosstalk vs. Frequency (RL=10k Ω)

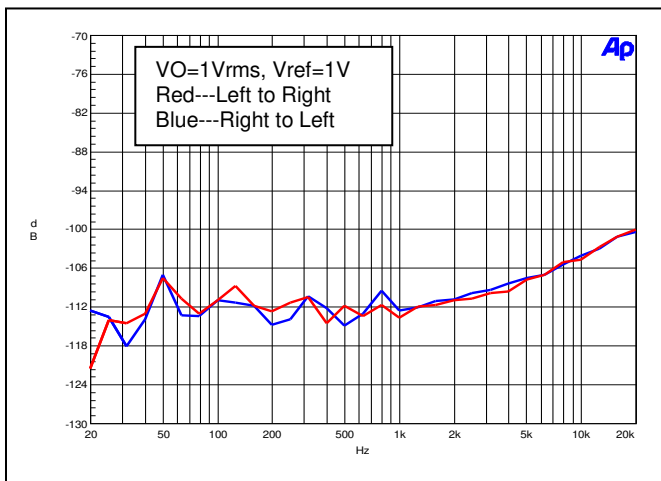

Gain vs. Frequency (RL=10k Ω)

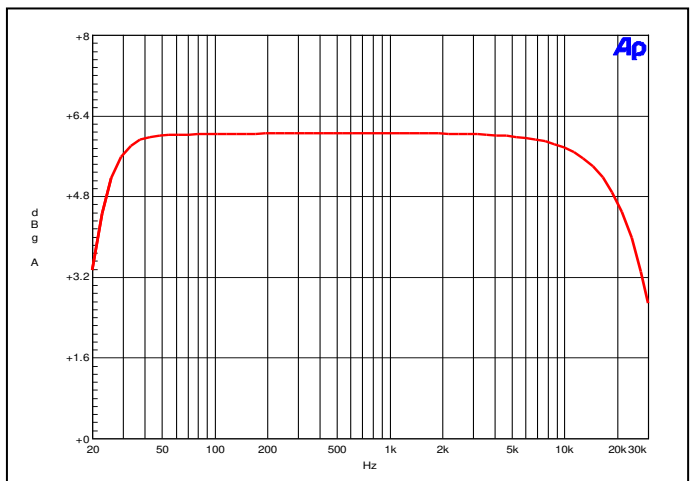

Ordering Information

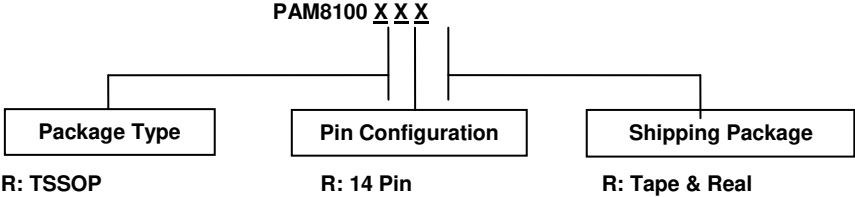

Part Number	Package Type	Shipping
PAM8100RRR	TSSOP-14	2,500/Tape & Real

Marking Information

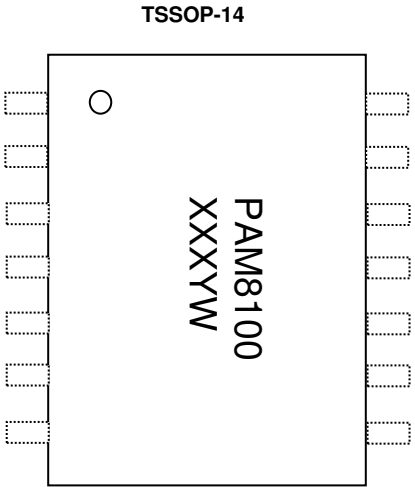

XXX: Internal Code
 Y: Year: 1, 2, 3 ~
 W: Week: "A~Z" means week 1 to week 26; "a~y" mean week 27 to 51, "z" means 52 and 53

Package Outline Dimensions (All dimensions in mm.)

Please see AP02002 at <http://www.diodes.com/datasheets/ap02002.pdf> for the latest version.

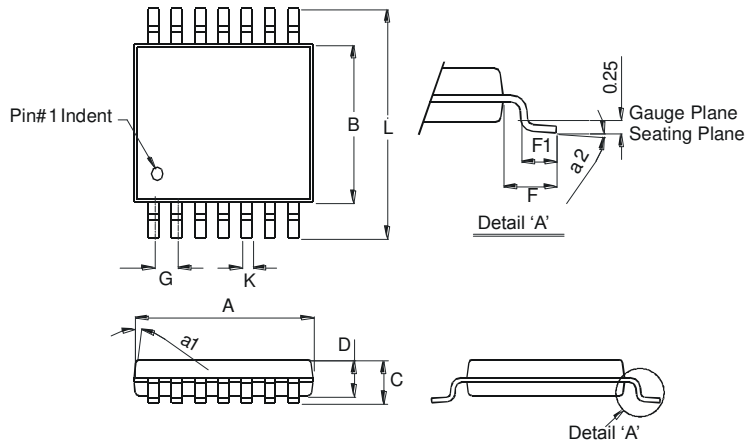

TSSOP-14		
Dim	Min	Max
a1	7° (4X)	
a2	0°	8°
A	4.9	5.10
B	4.30	4.50
C	—	1.2
D	0.8	1.05
F	1.00 Typ	
F1	0.45	0.75
G	0.65 Typ	
K	0.19	0.30
L	6.40 Typ	
All Dimensions in mm		

Suggested Pay Layout

Please see AP02001 at <http://www.diodes.com/datasheets/ap02001.pdf> for the latest version.

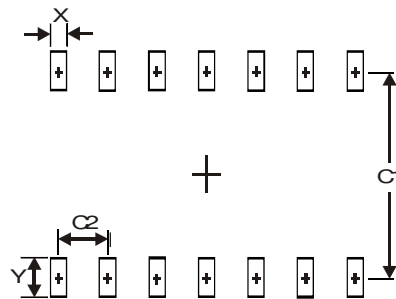

Dimensions	Value (in mm)
X	0.45
Y	1.45
C1	5.9
C2	0.65

IMPORTANT NOTICE

DIODES INCORPORATED MAKES NO WARRANTY OF ANY KIND, EXPRESS OR IMPLIED, WITH REGARDS TO THIS DOCUMENT, INCLUDING, BUT NOT LIMITED TO, THE IMPLIED WARRANTIES OF MERCHANTABILITY AND FITNESS FOR A PARTICULAR PURPOSE (AND THEIR EQUIVALENTS UNDER THE LAWS OF ANY JURISDICTION).

Diodes Incorporated and its subsidiaries reserve the right to make modifications, enhancements, improvements, corrections or other changes without further notice to this document and any product described herein. Diodes Incorporated does not assume any liability arising out of the application or use of this document or any product described herein; neither does Diodes Incorporated convey any license under its patent or trademark rights, nor the rights of others. Any Customer or user of this document or products described herein in such applications shall assume all risks of such use and will agree to hold Diodes Incorporated and all the companies whose products are represented on Diodes Incorporated website, harmless against all damages.

Diodes Incorporated does not warrant or accept any liability whatsoever in respect of any products purchased through unauthorized sales channel. Should Customers purchase or use Diodes Incorporated products for any unintended or unauthorized application, Customers shall indemnify and hold Diodes Incorporated and its representatives harmless against all claims, damages, expenses, and attorney fees arising out of, directly or indirectly, any claim of personal injury or death associated with such unintended or unauthorized application.

Products described herein may be covered by one or more United States, international or foreign patents pending. Product names and markings noted herein may also be covered by one or more United States, international or foreign trademarks.

This document is written in English but may be translated into multiple languages for reference. Only the English version of this document is the final and determinative format released by Diodes Incorporated.

LIFE SUPPORT

Diodes Incorporated products are specifically not authorized for use as critical components in life support devices or systems without the express written approval of the Chief Executive Officer of Diodes Incorporated. As used herein:

A. Life support devices or systems are devices or systems which:

1. are intended to implant into the body, or
2. support or sustain life and whose failure to perform when properly used in accordance with instructions for use provided in the labeling can be reasonably expected to result in significant injury to the user.

B. A critical component is any component in a life support device or system whose failure to perform can be reasonably expected to cause the failure of the life support device or to affect its safety or effectiveness.

Customers represent that they have all necessary expertise in the safety and regulatory ramifications of their life support devices or systems, and acknowledge and agree that they are solely responsible for all legal, regulatory and safety-related requirements concerning their products and any use of Diodes Incorporated products in such safety-critical, life support devices or systems, notwithstanding any devices- or systems-related information or support that may be provided by Diodes Incorporated. Further, Customers must fully indemnify Diodes Incorporated and its representatives against any damages arising out of the use of Diodes Incorporated products in such safety-critical, life support devices or systems.

Copyright © 2015, Diodes Incorporated

www.diodes.com