



Chipsmall Limited consists of a professional team with an average of over 10 year of expertise in the distribution of electronic components. Based in Hongkong, we have already established firm and mutual-benefit business relationships with customers from,Europe,America and south Asia,supplying obsolete and hard-to-find components to meet their specific needs.

With the principle of “Quality Parts,Customers Priority,Honest Operation,and Considerate Service”,our business mainly focus on the distribution of electronic components. Line cards we deal with include Microchip,ALPS,ROHM,Xilinx,Pulse,ON,Everlight and Freescale. Main products comprise IC,Modules,Potentiometer,IC Socket,Relay,Connector.Our parts cover such applications as commercial,industrial, and automotives areas.

We are looking forward to setting up business relationship with you and hope to provide you with the best service and solution. Let us make a better world for our industry!



## Contact us

Tel: +86-755-8981 8866 Fax: +86-755-8427 6832

Email & Skype: info@chipsmall.com Web: www.chipsmall.com

Address: A1208, Overseas Decoration Building, #122 Zhenhua RD., Futian, Shenzhen, China



## Description

The PAM8124 is a 15W efficient, Class-D audio power amplifier for driving stereo speakers in a single-ended configuration; or a mono speaker in a bridge-tied-load configuration. The PAM8124 can drive stereo speakers (SE) as low as 4Ω. Due to the low power dissipation and high efficiency, up to 95%, the device can be used without any external heat sink when playing music.

The gain of the amplifier is controlled by 2 gain selectable pins, offering 20dB, 26dB, 32dB, and 36dB gain selections.

The PAM8124 is available in a TSSOP-24-EP package.

## Features

- 30W/Ch into 8Ω BTL Load from 22V Supply
- 15W/Ch into 4Ω SE Load from 22V Supply
- 10W/Ch into 8Ω SE Load from 24V Supply
- Operate from 10V to 26V
- Single-Ended Analog Inputs
- Supports Multiple Output Configurations:
  - 2-Ch Single-Ended (SE, Half-Bridge)
  - 1-Ch Bridge-Tied Load (BTL, Full-Bridge)
- Four Selectable Fixed-gain Settings
- No Pop Noise for Start-up and Shut-down Sequences
- Internal Oscillator (No External Components Required)
- High Efficient Class-D Operation Eliminates Need for Heat Sinks
- Thermal and Short-Circuit Protection with Auto Recovery
- Space-Saving Surface-Mount TSSOP-24EP Package
- Pb-Free Package

## Pin Assignments

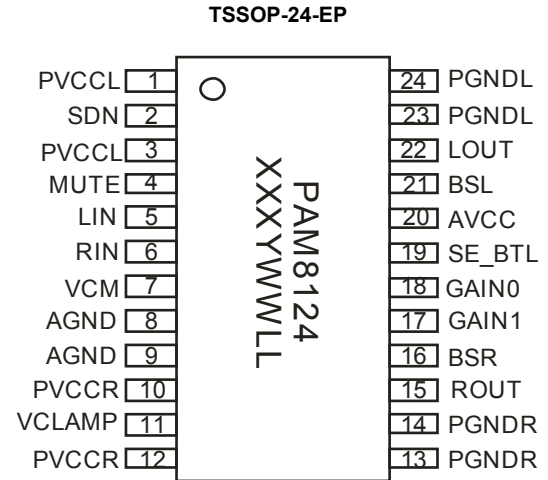

## Applications

- Televisions
- Home Sound Systems
- Active Speakers

## Typical Applications Circuit

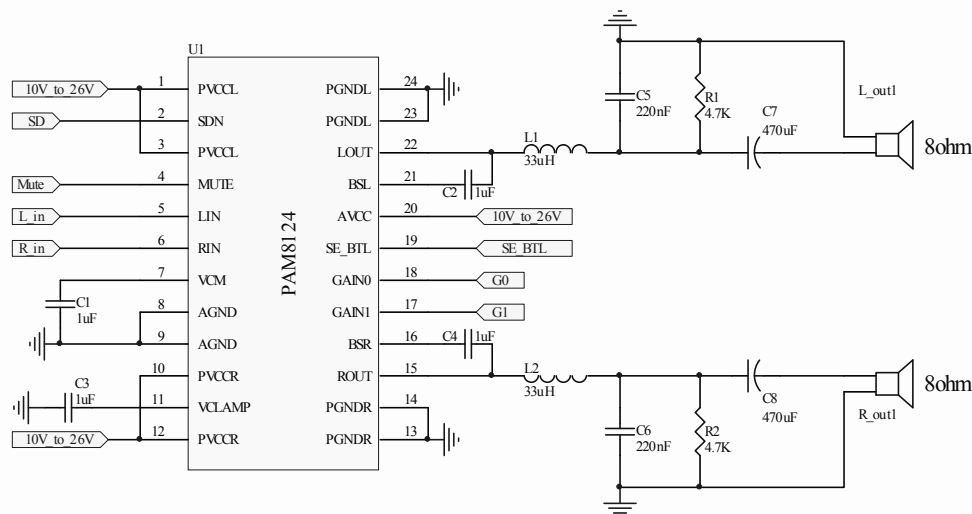

## Pin Descriptions

Pin	Name	I/O/P	Function
1, 3	PVCCCL	P	Power supply for left channel H-bridge, not connected to PVCCR or AVCC
2	SDN	I	Shutdown signal for IC (low = shutdown, high = operational). TTL logic levels with compliance to AVCC
4	MUTE	I	A logic high on this pin disables the outputs. A low on this pin enables the outputs. TTL logic levels with compliance to AVCC
5	LIN	I	Audio input for left channel
6	RIN	I	Audio input for right channel
7	VCM	O	Reference for analog cells
8, 9	AGND	P	Analog ground for digital/analog cells in core
10, 12	PVCCR	P	Power supply for right channel H-bridge, not connected to PVCCCL or AVCC
11	VCLAMP	P	Internally generated voltage supply for bootstrap. Not to be used as a supply or connected to any component other than the decoupling capacitor.
13, 14	PGNDR	P	Power ground for right channel H-bridge
15	ROUT	O	Class-D H-bridge output for right channel
16	BSR	I/O	Bootstrap I/O for right channel H-bridge
17	GAIN1	I	Gain select most-significant bit. TTL logic levels with compliance to AVCC
18	GAIN0	I	Gain select least-significant bit. TTL logic levels with compliance to AVCC
19	SE_BTL	I	A logic low on this pin enables one single-ended input in BTL configuration. A logic high on this pin enables two inputs in SE/BTL configuration. TTL logic levels with compliance to AVCC
20	AVCC	P	High-voltage analog power supply
21	BSL	I/O	Bootstrap I/O for left channel H-bridge
22	LOUT	O	Class-D H-bridge output for left channel
23, 24	PGNDL	P	Power ground for left channel H-bridge

## Functional Block Diagram

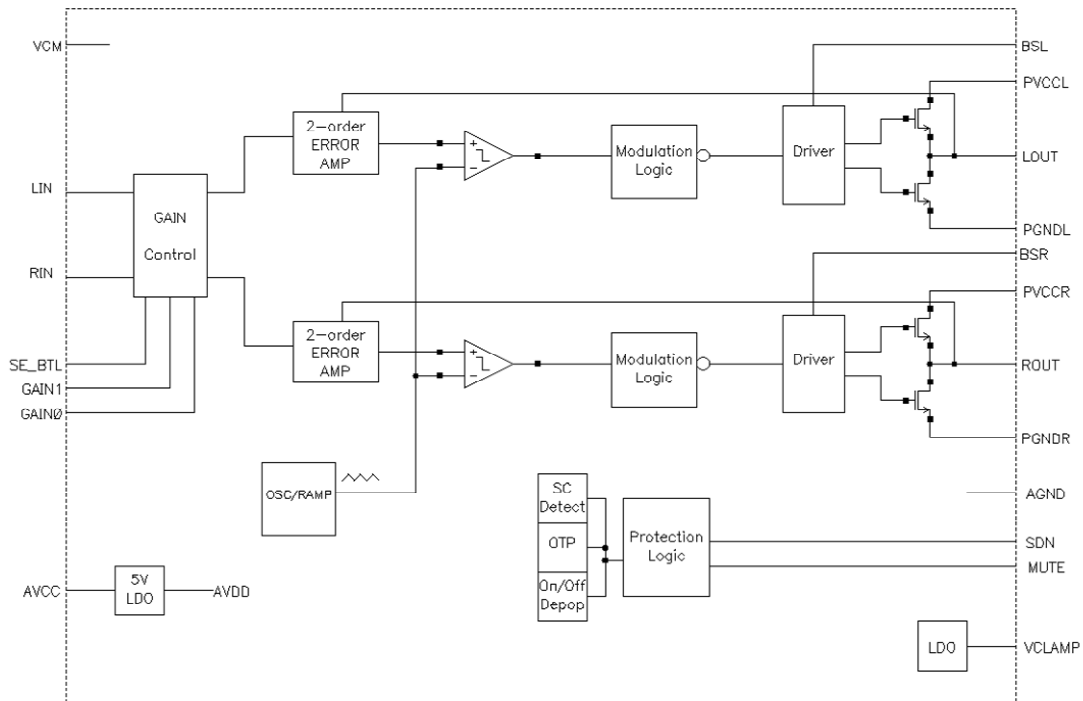

**Absolute Maximum Ratings** (@T<sub>A</sub> = +25°C, unless otherwise specified.)

Parameter	Rating	Unit
Supply Voltage (VCC)	28	V
Logic Input Voltage (SDN, MUTE, GAIN0, GAIN1, SE_BTL)	-0.3 to V <sub>CC</sub> +0.3	V
Analog Input Voltage (LIN, RIN)	-0.3 to +5.5	V
Storage Temperature	-65 to +150	°C
Maximum Junction Temperature	150	°C
Junction to ambient thermal resistance	40	°C/W

**Recommended Operating Conditions** (@T<sub>A</sub> = +25°C, unless otherwise specified.)

Symbol	Parameter	Min	Max	Unit
V <sub>CC</sub>	Supply Voltage	10	26	V
T <sub>A</sub>	Operating Ambient Temperature Range	-40	+85	°C
T <sub>J</sub>	Junction Temperature Range	-40	+125	°C

**Electrical Characteristics** (@T<sub>A</sub> = +25°C, V<sub>CC</sub> = 24V, Gain = 20dB, R<sub>L</sub> = 8Ω unless otherwise specified.)

Symbol	Parameter	Test Conditions	Min	Typ	Max	Units
VOS	Class-D output offset voltage(measured differently)	V <sub>i</sub> = 0V, A <sub>v</sub> = 36dB		20	100	mV
I <sub>CC(q)</sub>	Quiescent supply current	SDN = 2.5V, MUTE = 0V, No Load		25	40	mA
I <sub>CC(MUTE)</sub>	Quiescent supply current in mute mode	MUTE = 2.5V, No load		25	40	mA
I <sub>CC(SDN)</sub>	Quiescent current in shutdown mode	SDN = 0.8V, No load		30	60	μA
R <sub>DS(ON)</sub>	Drain-source on-state resistance	I <sub>O</sub> = 0.5A		150		mΩ
G	Gain	GAIN1 = 0.8V, GAIN0 = 0.8V	18	20	22	dB
		GAIN1 = 0.8V, GAIN0 = 2.5V	24	26	28	
		GAIN1 = 2.5V, GAIN0 = 0.8V	30	32	34	
		GAIN1 = 2.5V, GAIN0 = 2.5V	34	36	38	
	Mute Attenuation	V <sub>i</sub> = 1Vrms		-60		dB
PSRR	Power Supply Rejection Ratio	V <sub>RIPPLE</sub> = 200mVpp, f = 1kHz, gain = 20dB		-52		dB
P <sub>O</sub>	Output Power at 1% THD+N	R <sub>L</sub> = 4Ω, f = 1kHz		14		W
		R <sub>L</sub> = 8Ω, f = 1kHz		8		
	Output Power at 10% THD+N	R <sub>L</sub> = 4Ω, f = 1kHz		18		
		R <sub>L</sub> = 8Ω, f = 1kHz		10		
THD+N	Total harmonic distortion + noise	R <sub>L</sub> = 4Ω, f = 1kHz, P <sub>O</sub> = 10W		0.15		%
		R <sub>L</sub> = 8Ω, f = 1kHz, P <sub>O</sub> = 5W		0.08		
V <sub>n</sub>	Output integrated noise floor	20Hz to 22kHz, A-weighted, Gain = 20dB		200		μV
C <sub>s</sub>	Crosstalk	P <sub>O</sub> = 1W, f = 1kHz, Gain = 20dB		-70		dB
SNR	Signal-to-noise ratio	THD+N < 1%, f = 1kHz, Gain = 20dB		92		dB
OTP	Thermal trip point			160		°C
OTH	Thermal hysteresis			60		°C
fosc	Oscillator frequency	SE_BTL = 2.5V	250	300	350	kHz
		SE_BTL = 0.8V		360		

**Performance Characteristics** (@ $T_A = +25^\circ\text{C}$ ,  $V_{CC} = 24\text{V}$ ,  $f = 1\text{kHz}$ , Gain = 20dB unless otherwise specified.)

THD+N vs. Output Power ( $R_L = 4\Omega$ , SE)

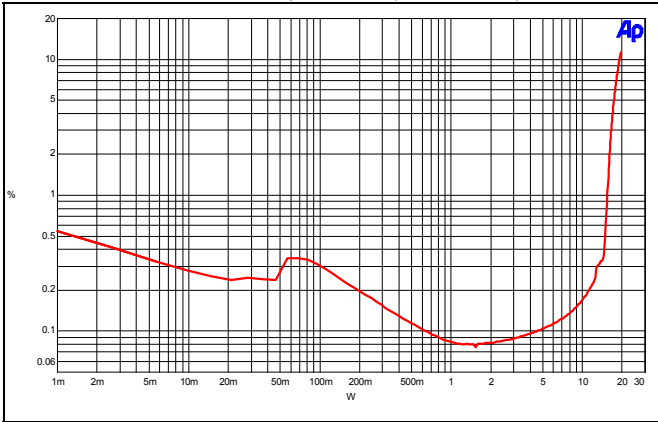

THD+N vs. Output Power ( $R_L = 8\Omega$ , SE)

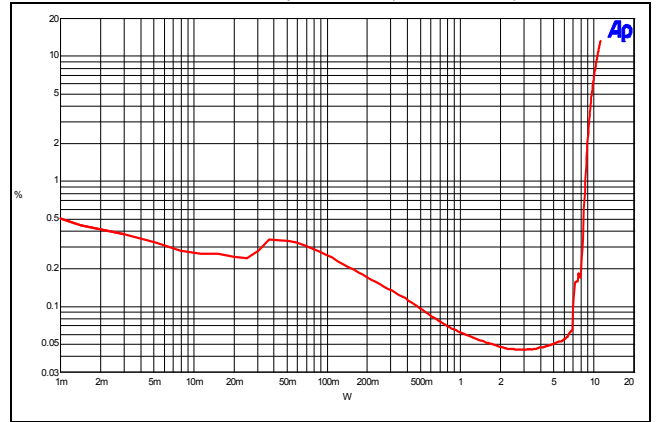

THD+N vs. Frequency ( $R_L = 4\Omega$ , SE)

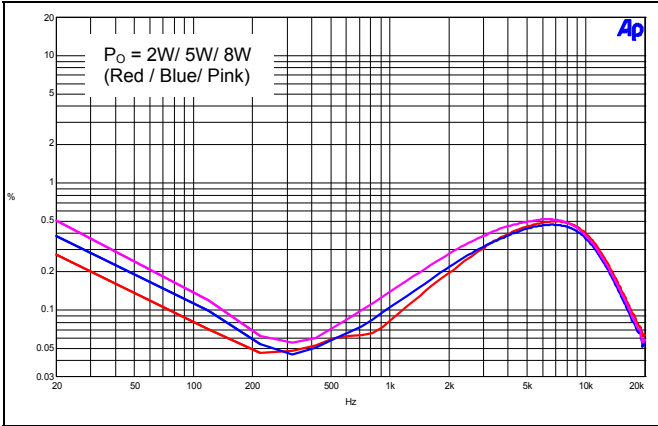

THD+N vs. Frequency ( $R_L = 8\Omega$ , SE)

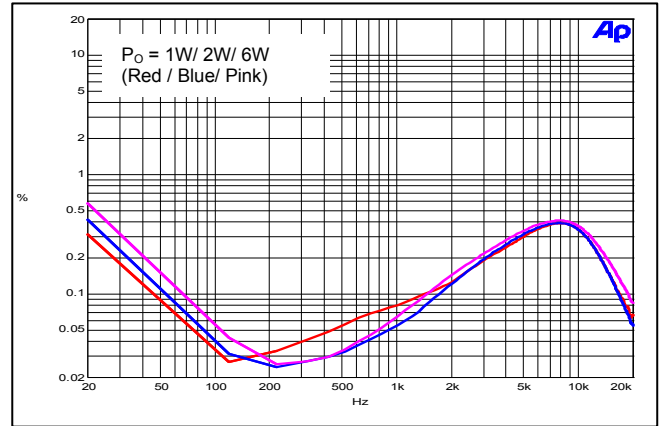

THD+N vs. Output Power ( $R_L = 8\Omega$ , BTL)

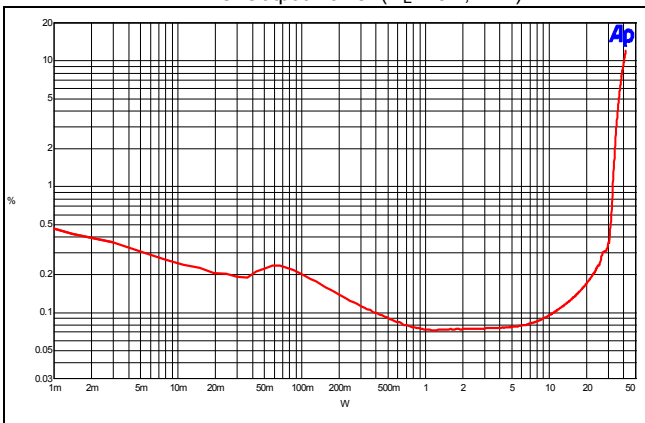

THD+N vs. Frequency ( $R_L = 8\Omega$ , BTL)

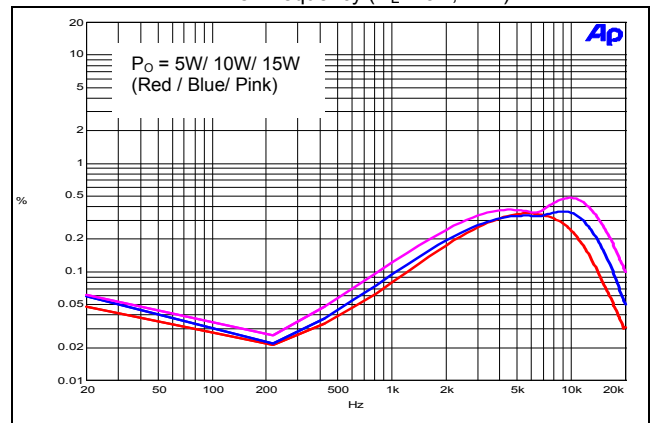

NEW PRODUCT

**Performance Characteristics** (@ $T_A = +25^\circ\text{C}$ ,  $V_{CC} = 24\text{V}$ ,  $f = 1\text{kHz}$ , Gain = 20dB unless otherwise specified.)

Crosstalk vs. Frequency ( $R_L = 4\Omega$ , SE)

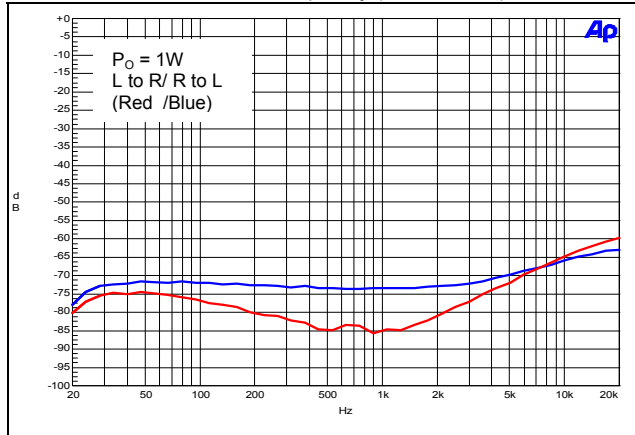

Crosstalk vs. Frequency ( $R_L = 8\Omega$ , SE)

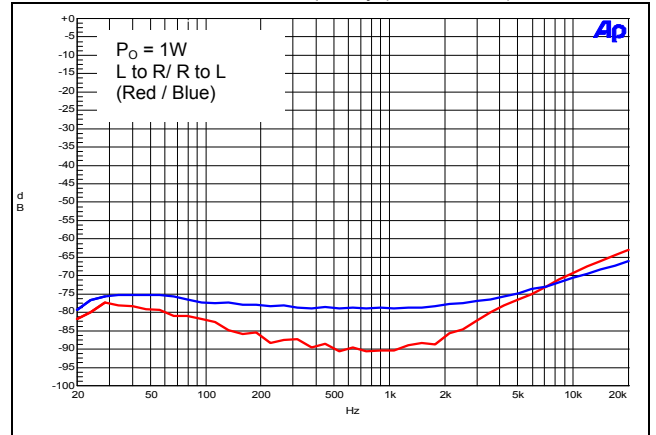

PSRR vs. Frequency ( $R_L = 4\Omega$ , SE)

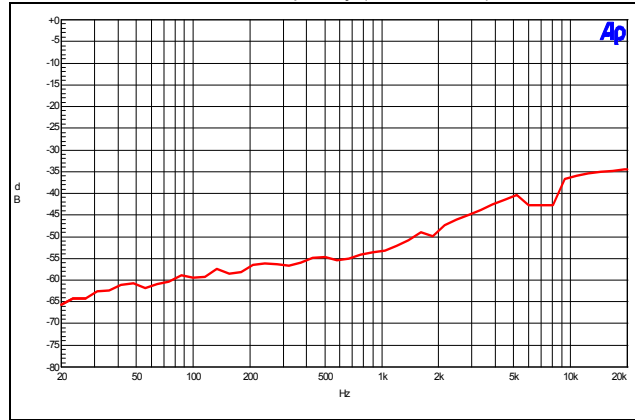

PSRR vs. Frequency ( $R_L = 8\Omega$ , SE)

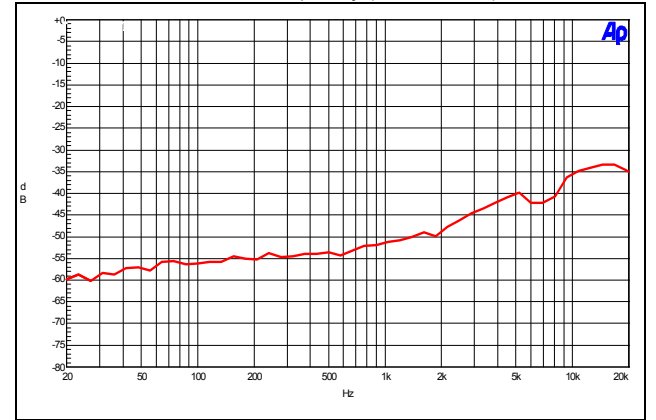

PSRR vs. Frequency ( $R_L = 8\Omega$ , BTL)

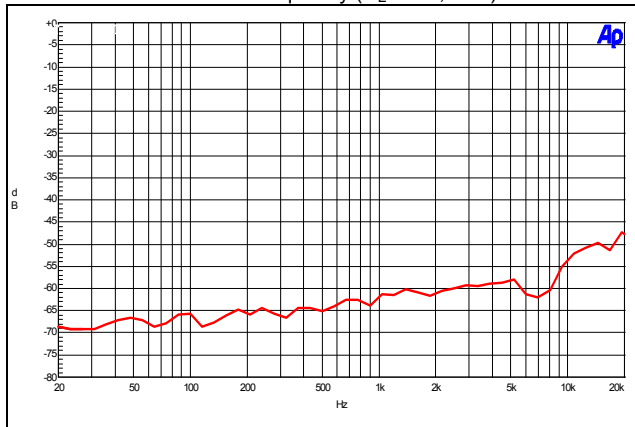

Noise Floor ( $R_L = 8\Omega$ , SE)

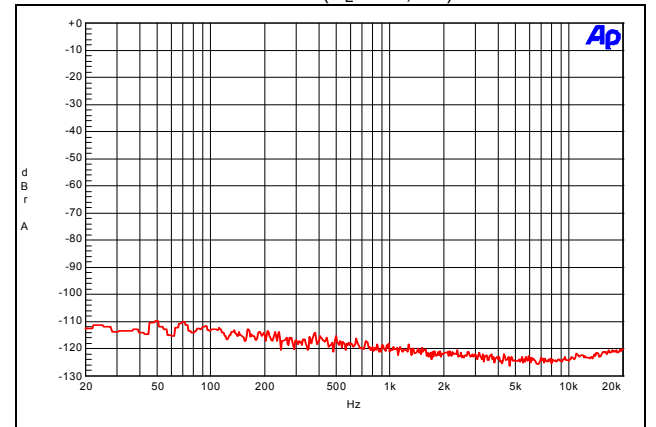

NEW PRODUCT

**Performance Characteristics** (@ $T_A = +25^\circ\text{C}$ ,  $V_{CC} = 24\text{V}$ ,  $f = 1\text{kHz}$ , Gain = 20dB unless otherwise specified.)

Frequency Response ( $R_L = 8\Omega$ , SE)

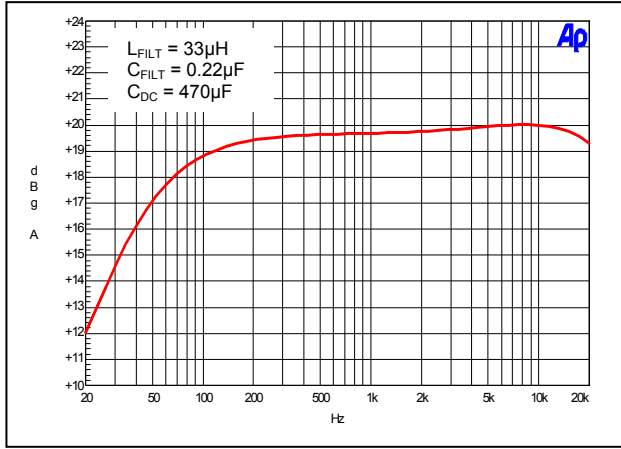

Frequency Response ( $R_L = 8\Omega$ , BTL)

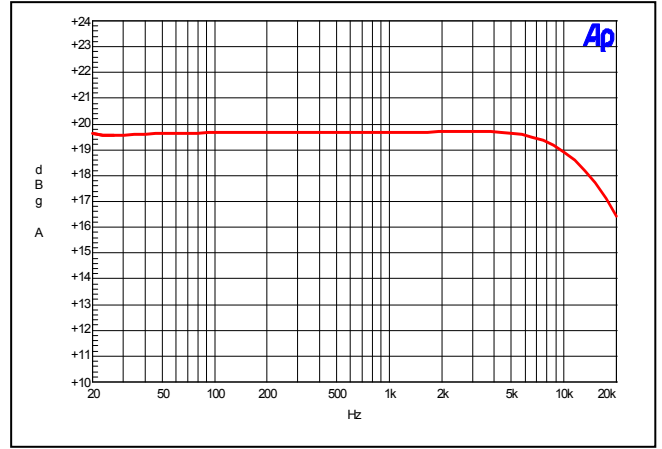

Efficiency vs. Output Power ( $R_L = 4\Omega$ )

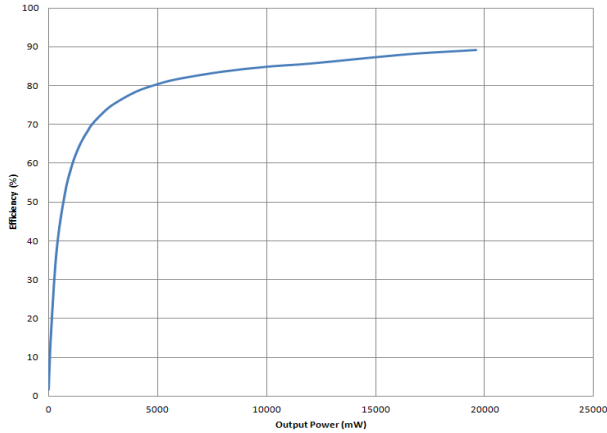

Efficiency vs. Output Power ( $R_L = 8\Omega$ )

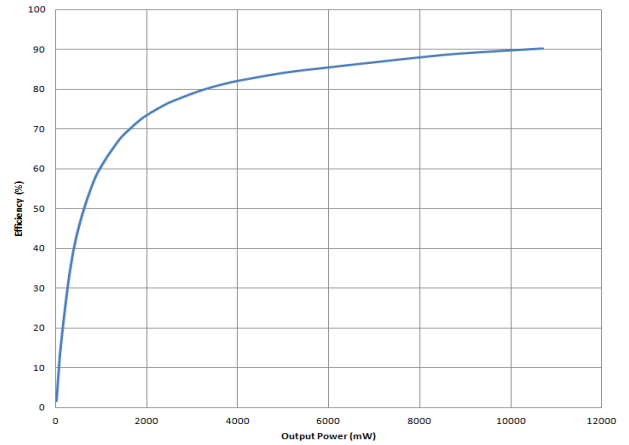

Quiescent Current vs. Supply Voltage

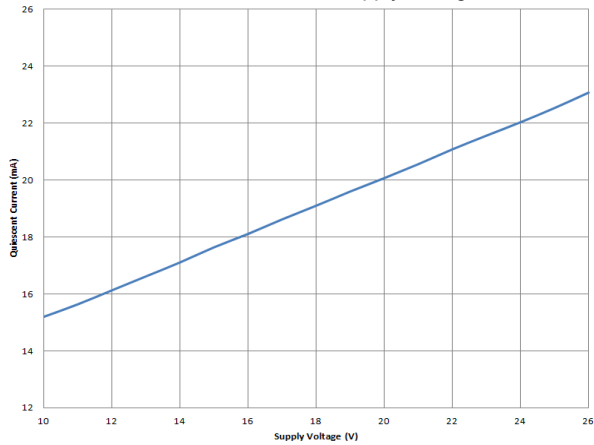

OSC Frequency vs. Supply Voltage

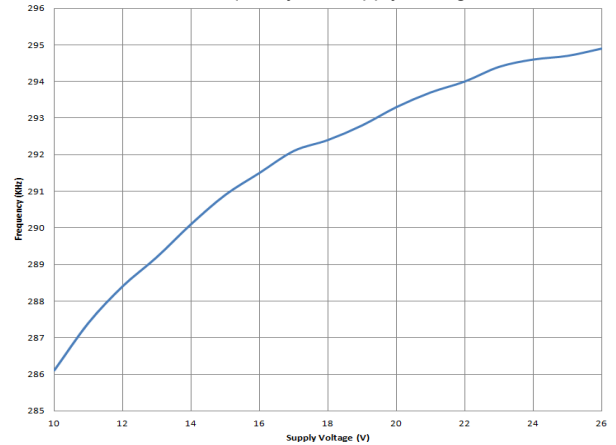

NEW PRODUCT

**Performance Characteristics** (@ $T_A = +25^\circ\text{C}$ ,  $V_{CC} = 24\text{V}$ ,  $f = 1\text{kHz}$ , Gain = 20dB unless otherwise specified.)

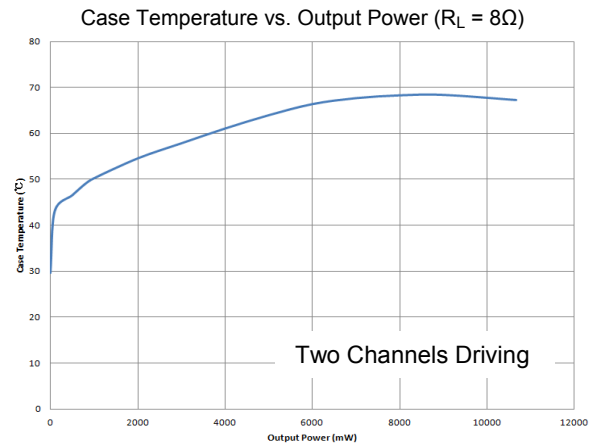
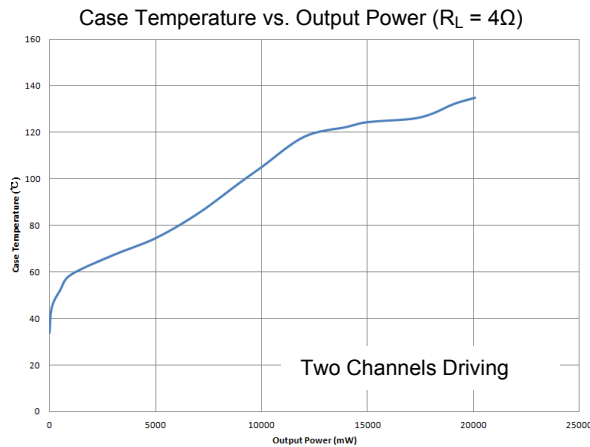

**Application Information**

**Input Capacitors (Ci)**

In the typical application, an input capacitor  $C_i$  is required to allow the amplifier to bias the input signal to the proper DC level for optimum operation. In this case,  $C_i$  and the minimum input impedance  $R_i$  form a high-pass filter with the corner frequency determined in the following equation:

$$f_c = \frac{1}{(2\pi R_i C_i)}$$

It is important to consider the value of  $C_i$  as it directly affects the low frequency performance of the circuit. For example, when  $R_i$  is 40k $\Omega$  and the specification calls for a flat bass response are down to 20Hz. Equation is reconfigured as followed:

$$C_i = \frac{1}{(2\pi R_i f_c)}$$

When input resistance variation is considered  $C_i$  is 200nF, so one would likely choose a value of 220nF. A further consideration for this capacitor is the leakage path from the input source through the input network ( $C_i$ ,  $R_i + R_f$ ) to the load. This leakage current creates a DC offset voltage at the input to the amplifier that reduces useful headroom, especially in high gain applications. For this reason, a low-leakage tantalum or ceramic capacitor is the best choice.

**Gain Setting Control**

The gain of the PAM8124 is set by two input terminals, GAIN0 and GAIN1.

The gains listed in following table are realized by changing the taps on the input resistors inside the amplifier. This causes the input impedance to be dependent on the gain setting. The actual gain settings are controlled by ratios of resistors, so the gain variation from part-to-part is small. However, the input impedance from part-to-part at the same gain may shift by  $\pm 20\%$  due to shifts in the actual resistance of the input resistors.

**Table 1: Gain Setting**

Gain1	Gain0	Amplifier Gain (dB), Typical	Input Impedance (k $\Omega$ ), Typical ( $R_i$ )
0	0	20	40
0	1	26	20
1	0	30	10
1	1	36	6.67



## Application Information (cont.)

### Input Resistance

Changing the gain setting can vary the input resistance of the amplifier from its smallest value (6.67kΩ ±20%) to the largest value (40kΩ ±20%). As a result, if a single capacitor is used in the input high-pass filter, the -3dB cutoff frequency may change when changing gain steps.

The -3dB frequency can be calculated using the following Equation. Use the Ri values given in Table 1.

$$f_c = \frac{1}{(2\pi R_i C_i)}$$

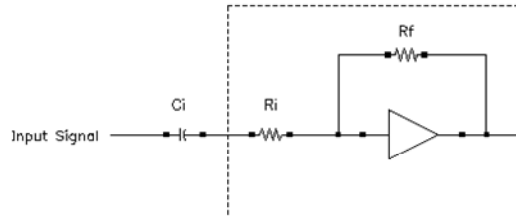

### Single-Ended Output Capacitor

In single-ended (SE) applications, the dc blocking capacitor forms a high-pass filter with the speaker impedance. The frequency response rolls off with decreasing frequency at a rate of 20dB/decade. The cutoff frequency is determined by:

$$f_{coh} = \frac{1}{2\pi R_L C_{SE}}$$

Table 2 shows some common component values and the associated cutoff frequencies:

**Table 2: Common Filter Responses**

R <sub>L</sub> -Speaker Impedance (Ω)	CSE-DC Blocking Capacitor (μF)		
	f <sub>c</sub> = 60Hz (-3dB)	f <sub>c</sub> = 40Hz (-3dB)	f <sub>c</sub> = 20Hz (-3dB)
4	680	1000	2200
6	470	680	1500
8	330	470	1000

### Output Filter and Frequency Response

For the best frequency response, a flat pass band output filter (second-order Butterworth) may be used. The output filter components consist of the series inductor and capacitor to ground at the LOUT and ROUT pins. There are several possible configurations, depending on the speaker impedance and whether the output configuration is single-ended (SE) or bridge-tied load (BTL). Table 3 lists the recommended values for the filter components. It is important to use a high-quality capacitor in this application. A rating of at least X7R is required.

**Table 3: Recommended Filter Output Components**

Output Configuration	Speaker Impedance(Ω)	Filter Inductor(μH)	Filter Capacitor(nF)
Single Ended (SE)	4	22	680
	8	33	220
Bridge Tied Load (BTL)	8	22	680

**Application Information (cont.)**

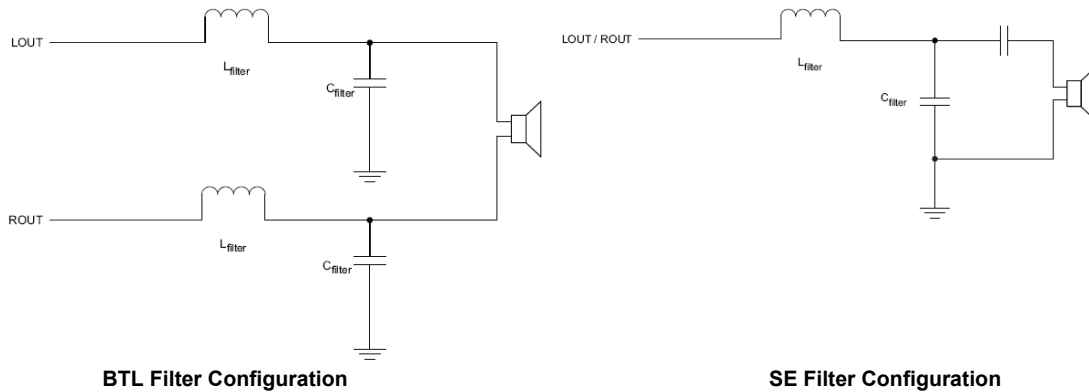

**Power and Heat Dissipation**

Choose speakers that are able to stand large output power from the PAM8124. Otherwise, speaker may suffer damage.

Heat dissipation is very important when the device works in full power operation. Two factors affect the heat dissipation, the efficiency of the device that determines the dissipation power, and the thermal resistance of the package that determines the heat dissipation capability.

Generally, class-D amplifiers are high efficiency and need no heat sink. Operating at higher powers a heat sink still may not be necessary if the PCB is carefully designed to achieve good thermal dissipation.

**How to Reduce EMI**

Most applications require a ferrite bead filter for EMI elimination shown at Figure 1. The ferrite filter reduces EMI around 1MHz and higher. When selecting a ferrite bead, choose one with high impedance at high frequencies, but low impedance at low frequencies.

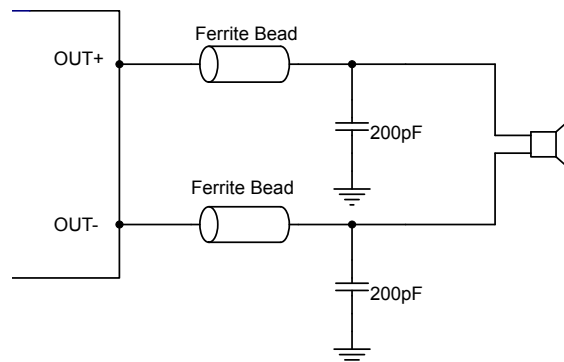

Figure 1. Ferrite Bead Filter to Reduce EMI

**Dual-Side PCB**

To achieve good heat dissipation, the PCB's copper plate should be thicker than 35um and the copper plate on both sides of the PCB should be utilized for heat sink. The thermal pad on the bottom of the device should be soldered to the plate of the PCB, and via holes, usually 9 to 16, should be drilled in the PCB area under the device and deposited copper on the vias should be thick enough so that the heat can be dissipated to the other side of the plate. There should be no insulation mask on the other side of the copper plate. It is better to drill more vias on the PCB around the device if possible.

## Application Information (cont.)

### MUTE Operation

The MUTE pin is an input for controlling the output state of the PAM8124. A logic high on this pin causes the outputs to run at a constant 50% duty cycle. A logic low on this pin enables the outputs. This pin may be used as a quick disable or enable of the outputs.

### Shutdown Operation

The PAM8124 employs a shutdown operation mode to reduce supply current to the absolute minimum level during periods of non-use to save power. The SDN input terminal should be pulling high during normal operation when the amplifier is in use. Pulling SDN low causes the outputs to mute and the amplifier to enter a low-current state. SDN should never be left unconnected to prevent the amplifier from unpredictable operation.

For the best power-off pop performance, the amplifier should be set in shutdown mode prior to removing the power supply voltage.

For the best start-up pop performance, the amplifier should be set in mute mode prior to restarting the amplifier.

### Internal Bias Generator Capacitor Selection

The internal bias generator (VCM) provides the internal bias for the preamplifier stage. The external input capacitors and this internal reference allow the inputs to be biased within the optimal common-mode range of the input preamplifiers.

The selection of the capacitor value on the VCM terminal is critical for achieving the best device performance. During startup or recovery from shutdown state the VCM capacitor determines the rate at which the amplifier starts up. The startup time is not critical for the best de-pop performance since any heard pop sound is the result of the class-D output switching-on other than that of the startup time. However, at least a 0.47 $\mu$ F capacitor is recommended for the VCM capacitor.

Another function of the VCM capacitor is to bypass high frequency noise on the internal bias generator.

### Power Supply Decoupling, CS

The PAM8124 is a high-performance CMOS audio amplifier that requires adequate power supply decoupling to ensure the output total harmonic distortion (THD) as low as possible. Power supply decoupling also prevents oscillations caused by long lead between the amplifier and the speaker. The optimum decoupling is achieved by using two capacitors of different types that target different types of noise on the power supply leads. For higher frequency transients, spikes, or digital hash on the line, a good low equivalent-series-resistance (ESR) ceramic capacitor of 0.1 $\mu$ F is typically recommended, placed as close as possible to the device's PVCC lead. To filter lower-frequency noises a large aluminium electrolytic capacitor of 470 $\mu$ F or greater is recommended, placed near the audio power amplifier. The 10 $\mu$ F capacitor also serves as a local storage capacitor for supplying current during large signal transients on the amplifier outputs.

### BSL and BSR Capacitors

The half H-bridge output stages use NMOS transistors therefore requiring bootstrap capacitors for the high side of each output to turn on correctly. A ceramic capacitor 220nF or more rated for over 25V must be connected from each output to its corresponding bootstrap input. Specifically, one 220nF capacitor must be connected from LOUT to BSL and another 220nF capacitor from ROUT to BSR. It is recommended to use 1 $\mu$ F BST capacitor to replace 220nF for lower than 100Hz applications.

### VCLAMP Capacitors

To ensure that the maximum gate-to-source voltage for the NMOS output transistors is not exceeded, an internal regulator is used to clamp the gate voltage. A 1 $\mu$ F capacitor must be connected from VCLAMP to ground and must be rated for at least 25V. The voltages at the VCLAMP terminals vary with VCC and may not be used to power any other circuitry.

### Using Low-ESR Capacitors

Low-ESR capacitors are recommended throughout this application section. A real (with respect to ideal) capacitor can be modeled simply as a resistor in series with an ideal capacitor. The voltage drop across this resistor minimizes the beneficial effects of the capacitor in the circuit. The lower the equivalent value of this resistance the more the real capacitor behaves as an ideal capacitor.

### Short-Circuit Protection

The PAM8124 has short circuit protection circuitry on the outputs to prevent damage to the device when output-to-output shorts (BTL mode), output-to-GND shorts, or output-to-VCC shorts occur. Once a short-circuit is detected on the outputs, the output drive is immediately disabled. This is not a latched fault. If the short was removed, the normal operation is restored.

## Application Information (cont.)

### Thermal Protection

Thermal protection on the PAM8124 prevents damage to the device when the internal die temperature exceeds 160°C. There is a ±15 degree tolerance on this trip point from device to device. Once the die temperature exceeds the set thermal point, the device enters into the shutdown state and the outputs are disabled. This is not a latched fault, the thermal fault is cleared once the temperature of the die is reduced by 60°C. The device begins normal operation at this point without external system intervention.

### Over Voltage Protection and Under Voltage Lock-out (OVP and UVLO)

An over voltage protection (OVP) circuit is integrated in PAM8124, when the supply voltage is over 28V the OVP is active and then the output stage is disabled. The PAM8124 will auto recovery when the supply voltage is lower than the OVP threshold.

The PAM8124 incorporates circuitry designed to detect low supply voltage. When the supply voltage drops to 9V or below, the PAM8124 goes into a state of shutdown. When the supply voltage is higher than UVLO threshold normal operation is resumed.

### Typical Applications Circuits

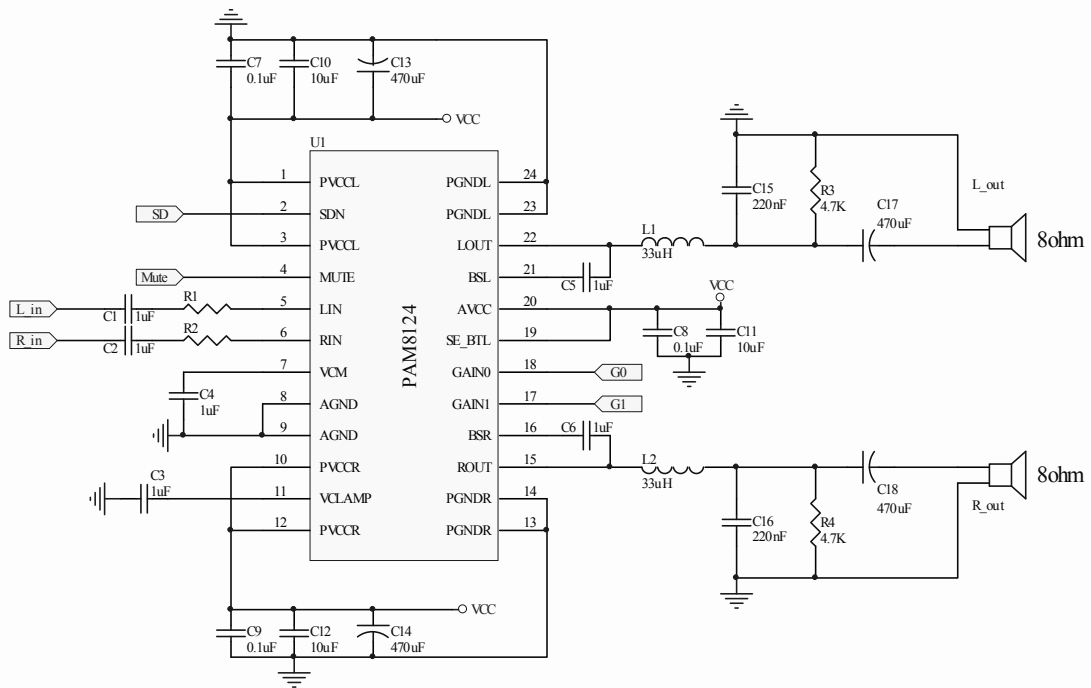

**Schematic for Single-Ended (SE) Configuration (8Ω Speaker)**

**Application Information (cont.)**

**Typical Applications Circuits (cont.)**

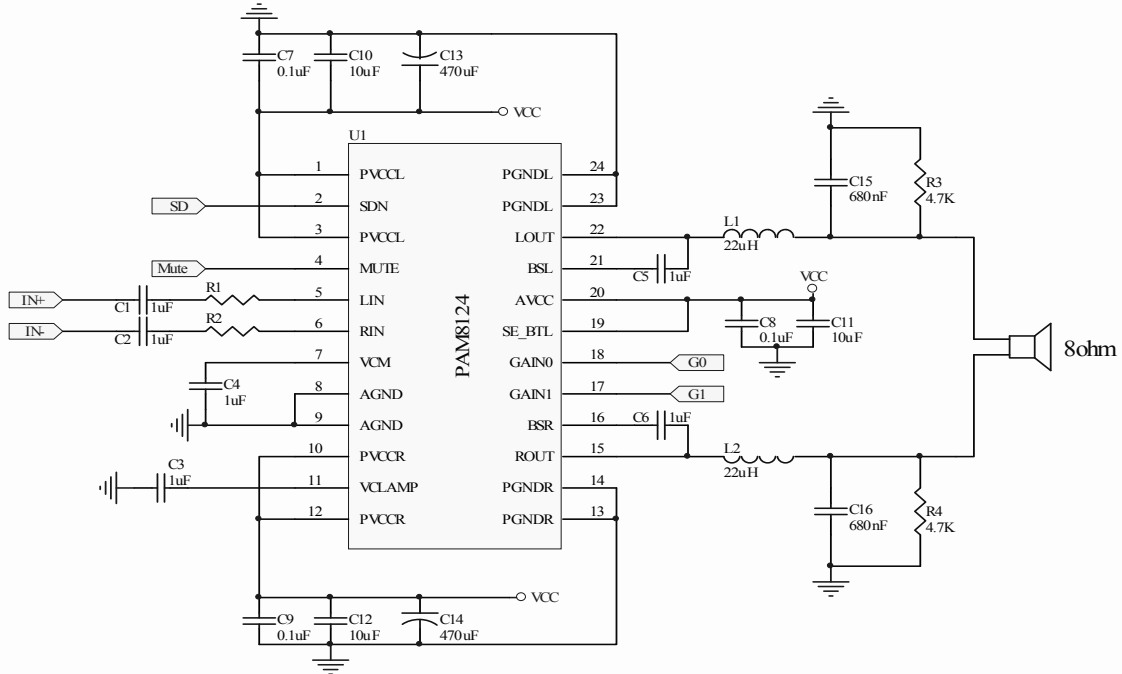

**Schematic for Bridge-Tied-Load (BTL) Configuration with Differential Input (8Ω Speaker)**

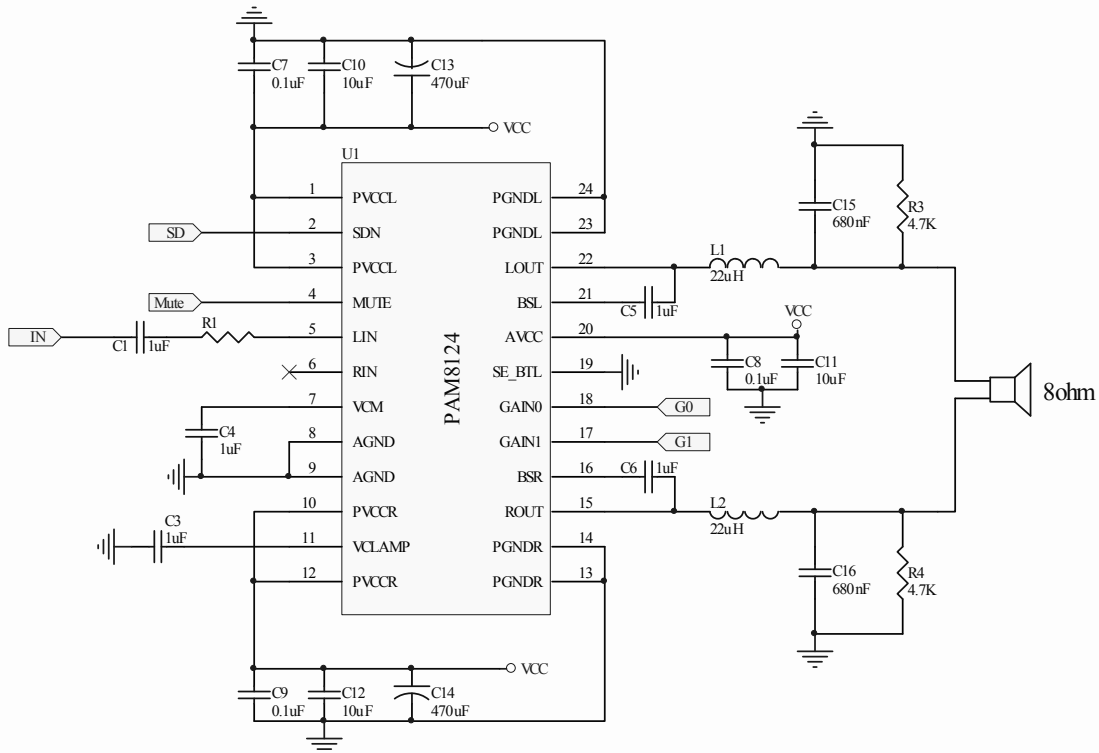

**Schematic for Bridge-Tied-Load (BTL) Configuration with Single-Ended Input (8Ω Speaker)**

NEW PRODUCT

**Ordering Information**

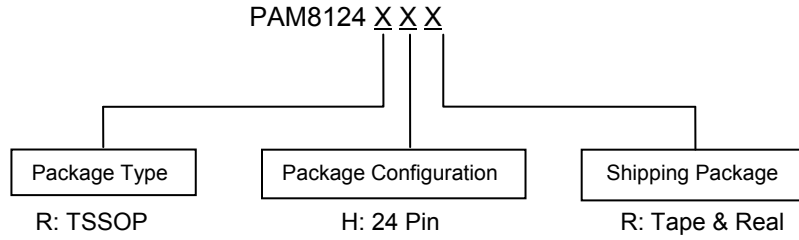

Part Number	Package	Standard Package
PAM8124RHR	TSSOP-24-EP	3000 Units/Tape&Reel

**Marking Information**

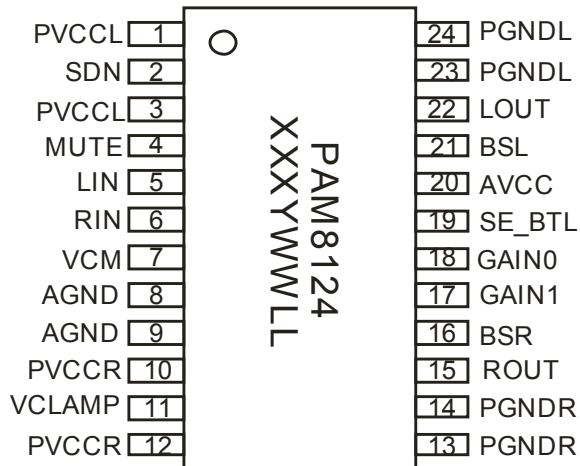

PAM8124: Product Code

X: Internal Code

Y: Year

W: Week

LL: Internal Code

NEW PRODUCT

**Package Outline Dimensions** (All dimensions in mm.)

Package: TSSOP-24-EP

NEW PRODUCT

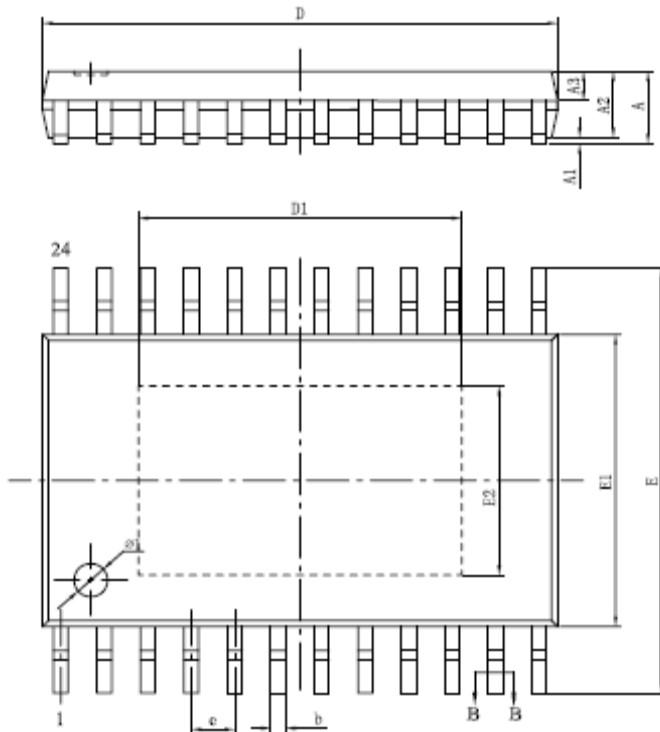

SYMBOL	MILLIMETER		
	MIN	NOM	MAX
A	—	—	1.20
A1	0.05	—	0.15
A2	0.80	1.00	1.05
A3	0.39	0.44	0.49
b	0.19	—	0.30
b1	0.19	0.22	0.25
c	0.09	—	0.20
c1	0.09	—	0.16
D	7.70	7.80	7.90
D1	4.73	4.83	4.93
E	6.20	6.40	6.60
E1	4.30	4.40	4.50
E2	2.75	2.85	2.95
e	0.65BSC		
L	0.45	0.60	0.75
L1	1.00BSC		
S	0.20	—	—
Ø1	Ø0.8X0.05-0.10DP		
θ	0	—	8°
L/封装尺寸 (mm)	122*190		

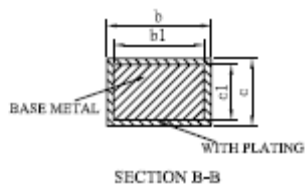

**IMPORTANT NOTICE**

DIODES INCORPORATED MAKES NO WARRANTY OF ANY KIND, EXPRESS OR IMPLIED, WITH REGARDS TO THIS DOCUMENT, INCLUDING, BUT NOT LIMITED TO, THE IMPLIED WARRANTIES OF MERCHANTABILITY AND FITNESS FOR A PARTICULAR PURPOSE (AND THEIR EQUIVALENTS UNDER THE LAWS OF ANY JURISDICTION).

Diodes Incorporated and its subsidiaries reserve the right to make modifications, enhancements, improvements, corrections or other changes without further notice to this document and any product described herein. Diodes Incorporated does not assume any liability arising out of the application or use of this document or any product described herein; neither does Diodes Incorporated convey any license under its patent or trademark rights, nor the rights of others. Any Customer or user of this document or products described herein in such applications shall assume all risks of such use and will agree to hold Diodes Incorporated and all the companies whose products are represented on Diodes Incorporated website, harmless against all damages.

Diodes Incorporated does not warrant or accept any liability whatsoever in respect of any products purchased through unauthorized sales channel. Should Customers purchase or use Diodes Incorporated products for any unintended or unauthorized application, Customers shall indemnify and hold Diodes Incorporated and its representatives harmless against all claims, damages, expenses, and attorney fees arising out of, directly or indirectly, any claim of personal injury or death associated with such unintended or unauthorized application.

Products described herein may be covered by one or more United States, international or foreign patents pending. Product names and markings noted herein may also be covered by one or more United States, international or foreign trademarks.

This document is written in English but may be translated into multiple languages for reference. Only the English version of this document is the final and determinative format released by Diodes Incorporated.

**LIFE SUPPORT**

Diodes Incorporated products are specifically not authorized for use as critical components in life support devices or systems without the express written approval of the Chief Executive Officer of Diodes Incorporated. As used herein:

A. Life support devices or systems are devices or systems which:

1. are intended to implant into the body, or
2. support or sustain life and whose failure to perform when properly used in accordance with instructions for use provided in the labeling can be reasonably expected to result in significant injury to the user.

B. A critical component is any component in a life support device or system whose failure to perform can be reasonably expected to cause the failure of the life support device or to affect its safety or effectiveness.

Customers represent that they have all necessary expertise in the safety and regulatory ramifications of their life support devices or systems, and acknowledge and agree that they are solely responsible for all legal, regulatory and safety-related requirements concerning their products and any use of Diodes Incorporated products in such safety-critical, life support devices or systems, notwithstanding any devices- or systems-related information or support that may be provided by Diodes Incorporated. Further, Customers must fully indemnify Diodes Incorporated and its representatives against any damages arising out of the use of Diodes Incorporated products in such safety-critical, life support devices or systems.

Copyright © 2013, Diodes Incorporated

[www.diodes.com](http://www.diodes.com)