



Chipsmall Limited consists of a professional team with an average of over 10 year of expertise in the distribution of electronic components. Based in Hongkong, we have already established firm and mutual-benefit business relationships with customers from,Europe,America and south Asia,supplying obsolete and hard-to-find components to meet their specific needs.

With the principle of “Quality Parts,Customers Priority,Honest Operation,and Considerate Service”,our business mainly focus on the distribution of electronic components. Line cards we deal with include Microchip,ALPS,ROHM,Xilinx,Pulse,ON,Everlight and Freescale. Main products comprise IC,Modules,Potentiometer,IC Socket,Relay,Connector.Our parts cover such applications as commercial,industrial, and automotives areas.

We are looking forward to setting up business relationship with you and hope to provide you with the best service and solution. Let us make a better world for our industry!



Contact us

Tel: +86-755-8981 8866 Fax: +86-755-8427 6832

Email & Skype: info@chipsmall.com Web: www.chipsmall.com

Address: A1208, Overseas Decoration Building, #122 Zhenhua RD., Futian, Shenzhen, China



Description

The PAM8904Q is a piezo sounder driver designed for driving a ceramic/piezo sounder or speaker with 18V_{PP} from a 3V power supply. A programmable charge pump boost converter allows the PAM8904Q V_{OUT} to operate in 1x, 2x and 3x mode.

The boost converter operates at a fixed frequency of 1.0MHz and provides a 9V output with a minimum number of external components. PAMs unique drive technology ensures minimal inrush current, low EMI and high efficiency.

To ensure maximum efficiency and battery life, the PAM8904Q includes an auto standby feature which puts the device in sleep mode while there is no valid input signal. A forced shutdown is also available to enable the IC only when required.

To help protect the IC and system, the PAM8904Q includes overtemperature shutdown, overcurrent and short circuit protection.

The PAM8904Q is available in a 16 pin U-QFN3030-16 (Type B) package.

The PAM8904Q is qualified to AEC-Q100 Grade 2 and is Automotive Compliant supporting PPAPs.

Features

- Supply Voltage Range from 2.3V to 5V
- 18V_{PP} Output from a 3V Supply
- Integrated Boost Converter Generates 9V Supply
- Wide Input Signal Capability 20Hz to 300kHz
- Low Current Consumption
- Automatic Standby and Wake-up Control
- Overtemperature Shutdown and Short-Circuit Protection
- Available in Space Saving Packages 16 pin U-QFN3030-16 (Type B) Package with Green Molding
- **Totally Lead-Free & Fully RoHS Compliant (Notes 1 & 2)**
- **Halogen and Antimony Free. "Green" Device (Note 3)**
- **Qualified to AEC-Q100 Standards for High Reliability**
- **AEC-Q100 Grade 2**
- **PPAP Capable (Note 4)**

- Notes:
1. No purposely added lead. Fully EU Directive 2002/95/EC (RoHS) & 2011/65/EU (RoHS 2) compliant.
 2. See http://www.diodes.com/quality/lead_free.html for more information about Diodes Incorporated's definitions of Halogen and Antimony-free, "Green" and Lead-free.
 3. Halogen- and Antimony-free "Green" products are defined as those which contain <900ppm bromine, <900ppm chlorine (<1500ppm total Br + Cl) and <1000ppm antimony compounds.
 4. Automotive products are AEC-Q100 qualified and are PPAP capable. Refer to http://www.diodes.com/product_compliance_definitions.html.

Pin Assignments

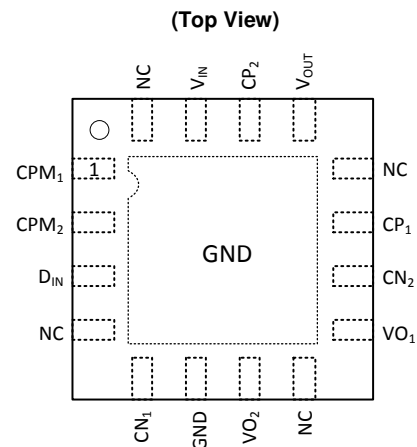

U-QFN3030-16 (Type B)

Applications

- Automotive Alarms
- Dash Board Audio
- GPS
- Electric Vehicle Approach Warning
- Automotive Security Device

Typical Applications Circuit

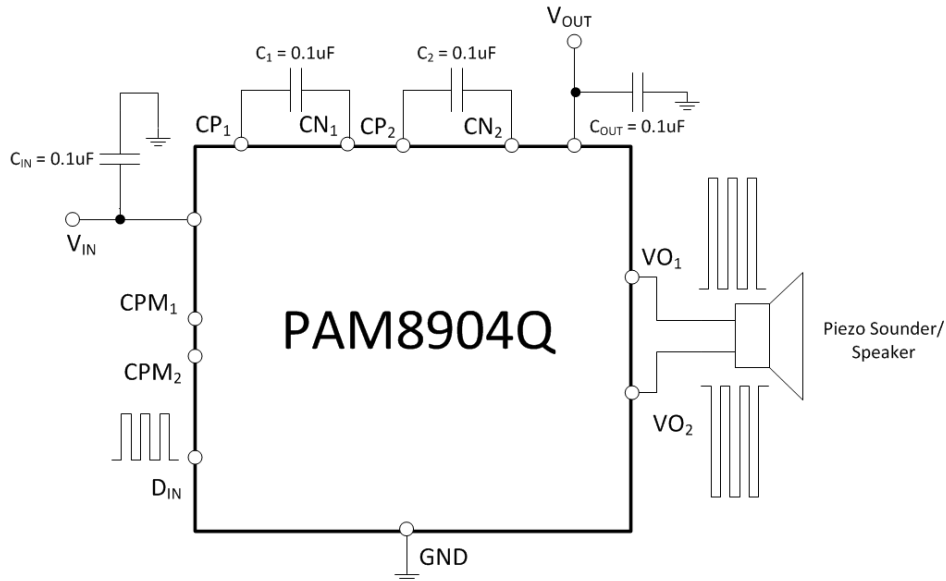

Pin Descriptions

Pin Number	Pin Name	I/O/P	Function
1	CPM ₁	I	Charge pump mode select 1
2	CPM ₂	I	Charge pump mode select 2
3	D _{IN}	I	Signal Input
4	NC	—	No Connection
5	CN ₁	I	Capacitor 1 Negative Terminal
6	GND	P	Ground
7	VO ₂	O	Positive Output
8	NC	—	No Connection
9	VO ₁	O	Negative Output
10	CN ₂	I	Capacitor 2 Negative Terminal
11	CP ₁	I	Capacitor 1 Positive Terminal
12	NC	—	No Connection
13	V _{OUT}	O	Boost Output
14	CP ₂	I	Capacitor 2 Positive Terminal
15	V _{IN}	P	Power Supply
16	NC	—	No Connect
PAD	GND	P	Recommended to connect to GND or No Connection

Absolute Maximum Ratings (@T_A = +25°C, unless otherwise specified.)

Symbol	Characteristics	Value	Unit
V _{IN}	Supply Voltage	-0.3 to +5.5	V
V _I	CPM ₁ , CPM ₂	GND -0.3 to V _{IN} +0.3	V
θ _{JA}	Thermal Resistance (Junction to Ambient)	35	°C/W
θ _{JC}	Thermal Resistance (Junction to Case)	14	°C/W
T _J	Operating Junction Temperature Range	-40 to +150	°C
T _{STG}	Storage Temperature Range	-65 to +150	°C

ESD Susceptibility

HBM	Human Body Model	8	kV
MM	Machine Model	600	V
CDM	Charged Device Model	1	kV

Caution: Stresses greater than the 'Absolute Maximum Ratings' specified above, may cause permanent damage to the device. These are stress ratings only; functional operation of the device at conditions between maximum recommended operating conditions and absolute maximum ratings is not implied. Device reliability may be affected by exposure to absolute maximum rating conditions for extended periods of time.

(Semiconductor devices are ESD sensitive and may be damaged by exposure to ESD events. Suitable ESD precautions should be taken when handling and transporting these devices.)

Recommended Operating Conditions (@T_A = +25°C, unless otherwise specified.)

Symbol	Characteristics	Min	Max	Unit
V _{IN}	Supply Voltage	2.3	5.0	V
V _{IH}	High-Level Input Voltage	CPM ₁ , CPM ₂	V _{IN} +0.3	V
V _{IL}	Low-Level Input Voltage	CPM ₁ , CPM ₂	+0.4	V
T _A	Operating Free-Air Temperature	-40	+105	°C

Electrical Characteristics (@ $T_A = +25^\circ\text{C}$, unless otherwise specified.)

Symbol	Parameter	Conditions	Min	Typ	Max	Unit
V_{OUT}	Output Voltage Range	Note 5	2.1	—	12	V
V_{OUT1}	Output Voltage	1x Mode	2.8	—	3	V
V_{OUT2}		2x Mode	5.2	—	6	V
V_{OUT3}		3x Mode	7.2	—	9	V
I_{DD11}	Operating Current 1	1x Mode, $C_{PIEZO} = \text{No Load}$	—	50	—	μA
I_{DD12}		2x Mode, $C_{PIEZO} = \text{No Load}$	—	720	—	μA
I_{DD13}		3x Mode, $C_{PIEZO} = \text{No Load}$	—	1,700	—	μA
I_{DD21}	Operating Current 2	1x Mode, Single-ended application	—	0.3	—	mA
I_{DD22}		2x Mode, Single-ended application	—	1.4	—	mA
I_{DD23}		3x Mode, Single-ended application	—	3.9	—	mA
I_{DD31}	Operating Current 3	1x Mode, Differential application	—	0.9	—	mA
I_{DD32}		2x Mode, Differential application	—	3.8	—	mA
I_{DD33}		3x Mode, Differential application	—	8.5	—	mA
I_{SD}	Shutdown Current	$D_{IN} = 0\text{V}$	—	—	1	μA
f_{IN}	Input Frequency	Rectangular pulse on D_{IN}	0.02	—	300	kHz
f_{OSC}	Oscillating Frequency	—	—	1	—	MHz
t_{ON1}	V_{OUT} Start Delay Time	1x Mode, From D_{IN} signal High to 90% V_{OUT} steady state	—	270	—	μs
t_{ON2}		2x Mode, From D_{IN} signal High to 90% V_{OUT} steady state	—	320	—	μs
t_{ON3}		3x Mode, From D_{IN} signal High to 90% V_{OUT} steady state	—	350	—	μs
t_{OFF}	Shutdown Delay Time	$D_{IN} = H \rightarrow L$	—	42	—	ms
I_{SC}	Output Short-Circuit Current	—	—	40	—	mA
OTP	Thermal Shutdown	Junction temperature	—	+150	—	$^\circ\text{C}$
OTP _{HYS}	Thermal Shutdown Hysteresis	—	—	+37	—	$^\circ\text{C}$
V_{IH}	Control Terminal Voltage H	CPM ₁ , CPM ₂ , D_{IN} pins	$0.8 \times V_{IN}$	—	V_{IN}	V
V_{IL}	Control Terminal Voltage L	CPM ₁ , CPM ₂ , D_{IN} pins	0	—	$0.2 \times V_{IN}$	V
I_{IH1}	Control Terminal Current 1	$D_{IN} = 3\text{V}$	—	—	1	μA
I_{IH2}	Control Terminal Current 2	VCPM ₁ , VCPM ₂ = 3V, $D_{IN} = 3\text{V}$	—	—	1	μA
I_{IH3}	Control Terminal Current 3	VCPM ₁ , VCPM ₂ = 3V, $D_{IN} = 0\text{V}$	—	—	1	μA
C_L	Capacitive Load	—	—	15	50	nF

Note: 5. It is possible to drive V_{OUT} , VO_1 and VO_2 to $3x V_{DD}$. A supply voltage of 4V or more should not be used in 3x mode as this will exceed the maximum output voltage rating.

Performance Characteristics (@ $T_A = +25^\circ\text{C}$, $V_{IN} = 3.0\text{V}$, $C_{Piezo} = 15\text{nF}$, $f_{DIN} = 4\text{kHz}$, unless otherwise specified.)

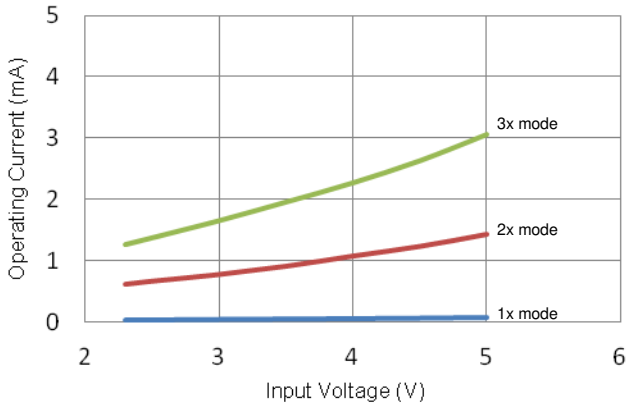

Operating Current vs Input Voltage (No Load)

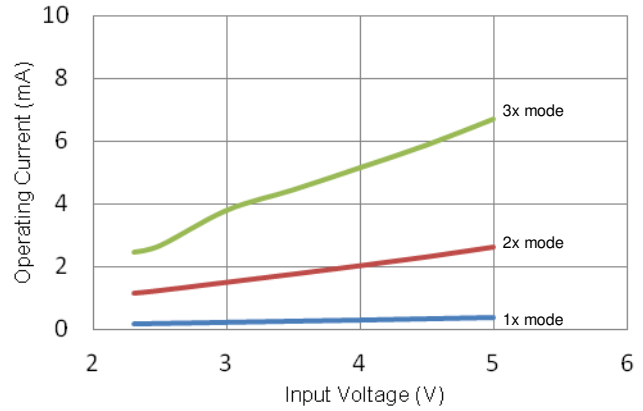

Operating Current vs Input Voltage (Single Ended Output)

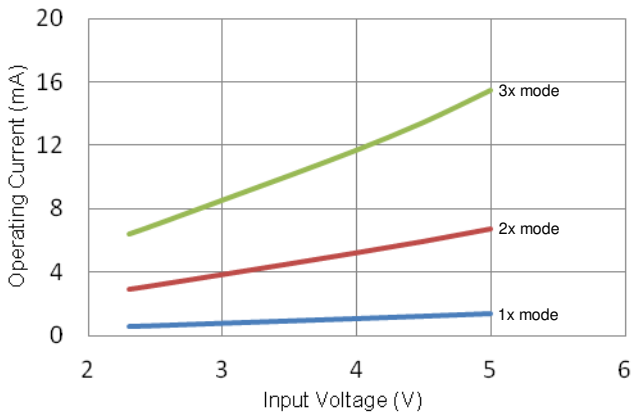

Operating Current vs Input Voltage (Differential output)

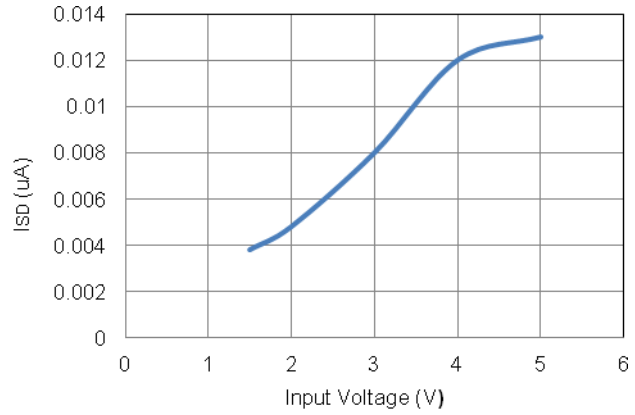

Shutdown Current vs Input Voltage

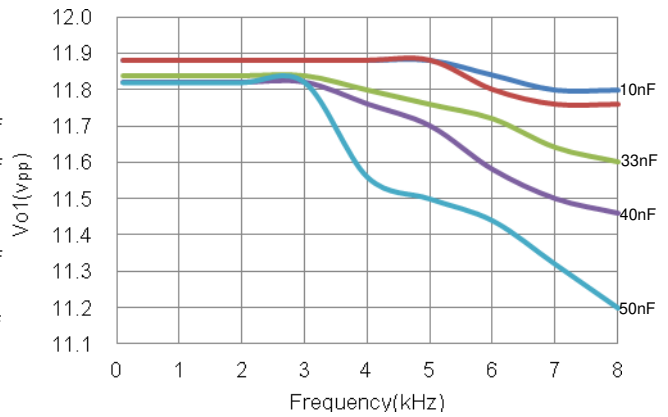
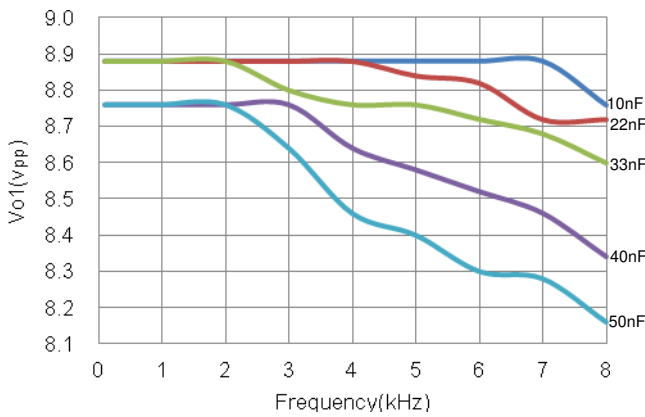

Performance Characteristics (Cont. @ $T_A = +25^\circ\text{C}$, $V_{IN} = 3.0\text{V}$, $C_{Piezo} = 15\text{nF}$, $f_{DIN} = 4\text{kHz}$, unless otherwise specified.)

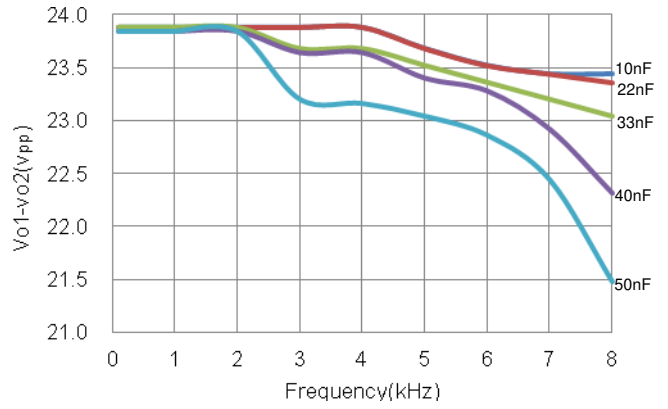
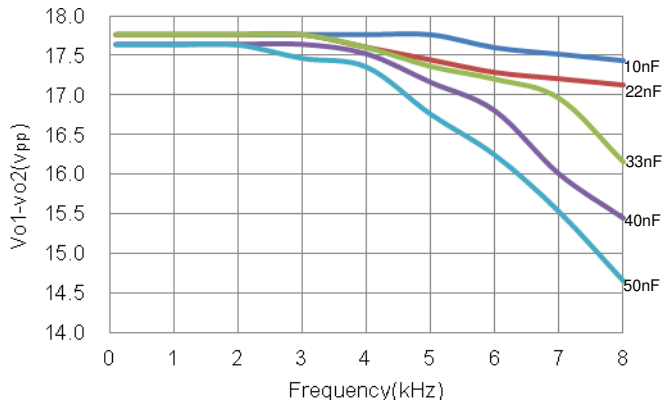

Application Information

Charge Pump Mode Setting

The Charge Pump Mode (CPM) pins CPM₁ and CPM₂ are used to set the charge pump into mode 1x V_{DD}, 2x V_{DD}, 3x V_{DD} or they can be used to put the PAM8904Q in to a forced low current shutdown mode.

D _{IN}	CPM ₁	CPM ₂	MODE
0	—	—	Shutdown Mode
1	0	0	Shutdown Mode
1	0	1	1x Mode
1	1	0	2x Mode
1	1	1	3x Mode

Care must be taken when using the 3x mode with a V_{DD} supply of 4V or more as this will force the V_{OUT} to exceed its maximum specification. The table shows the safe operating range of the PAM8904Q.

V _{DD} Range	Mode
2.3V to 3.9V	1x, 2x and 3x
4.0V to 5.0V	1x and 2x only

Timing Chart and Device Operation

When one or both of the CPM pins are pulled high, the device enters normal operation mode, refer to the above table for the mode selection. Once the PAM8904Q senses a valid signal on the D_{IN} pin, the charge pump will start and provide the desired voltage on the V_{OUT} pin and the output drive VO₁ and VO₂ start to function after time t_{ON} which is typically between 270μs and 350μs depending on the mode chosen. Once the input signal on D_{IN} is removed, the PAM8904Q senses this and waits typically 42ms to ensure the signal has been removed. If there is no further valid signal within the time period t_{OFF}, the PAM8904Q enters into a low current standby mode.

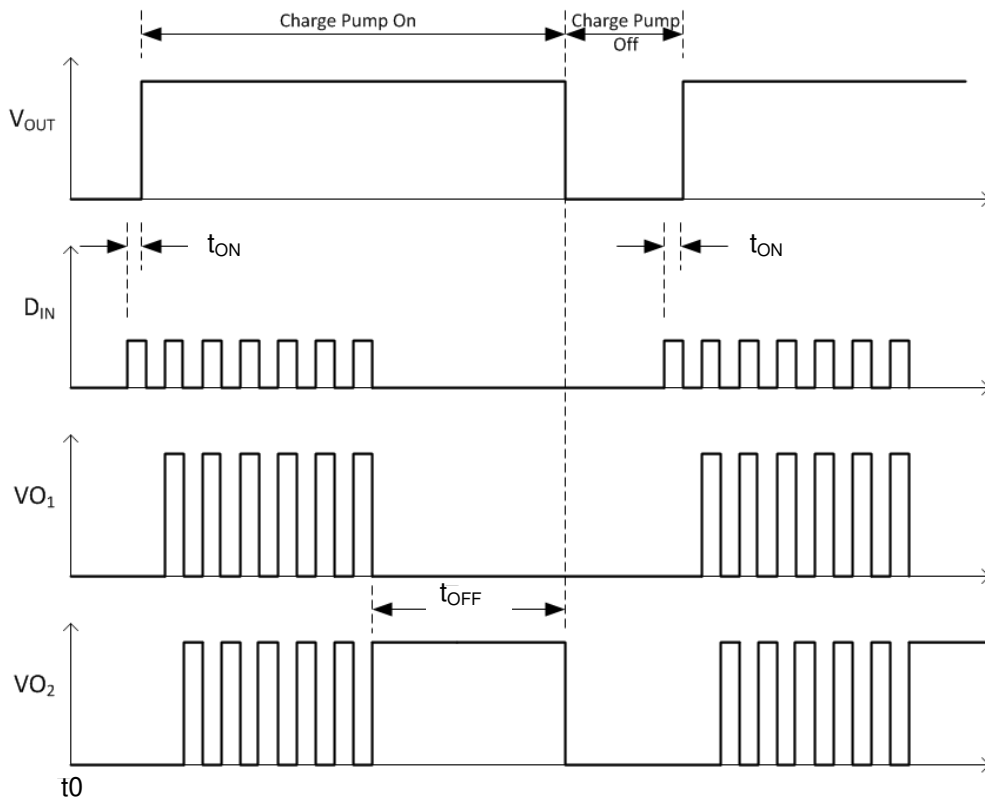

Application Information (Cont.)

Output Configuration

The PAM8904Q is able to be configured either in a differential or a single ended configuration.

Differential Output Typical Application Circuit

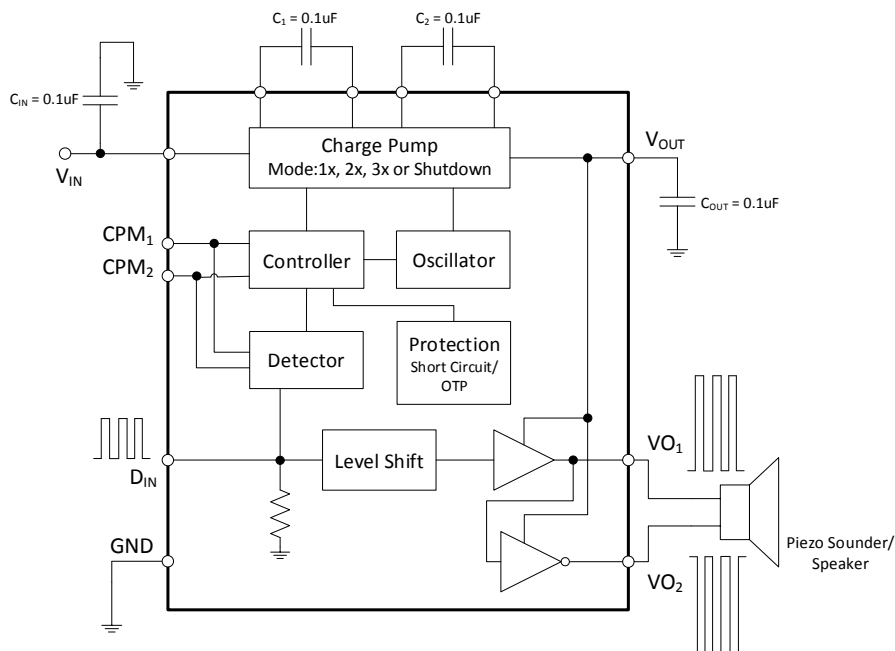

Single Ended Output Typical Application Circuit

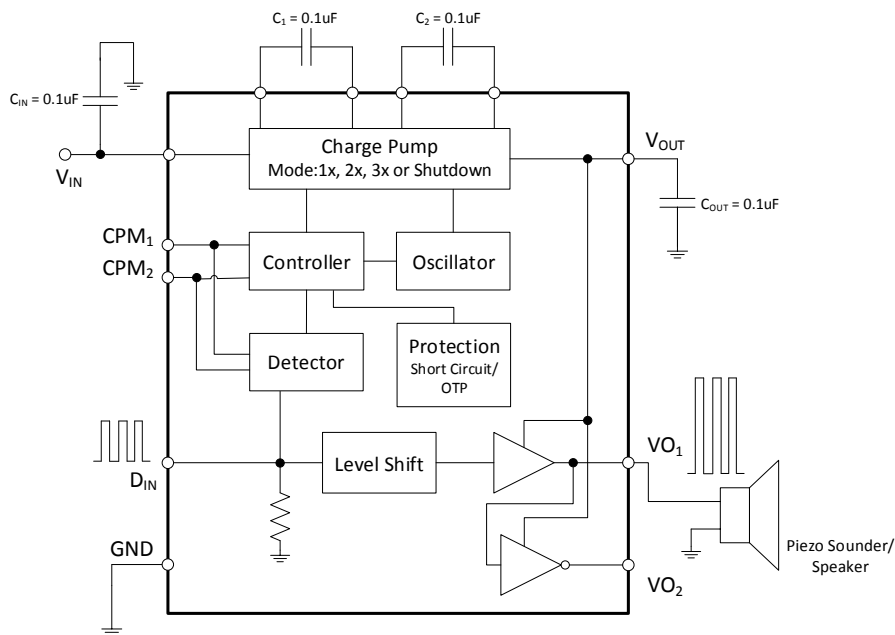

When using the PAM8904Q with a single ended output, the VO_2 pin should be left open circuit.

Application Information (Cont.)

Short-Circuit Protection

The PAM8904Q has short circuit protection circuitry on the outputs to prevent damage. Once a short circuit is detected on the outputs the chip will limit the total current to protect the output device. This is not a latched fault; once the short is removed the normal operation is restored.

Thermal Protection

If the junction temperature of the PAM904Q exceeds +150°C the device will enter overtemperature shutdown. The outputs and the charge pump will be switched off. Once the junction temperature cools down to its normal operating condition, the IC will re-start automatically.

Ordering Information

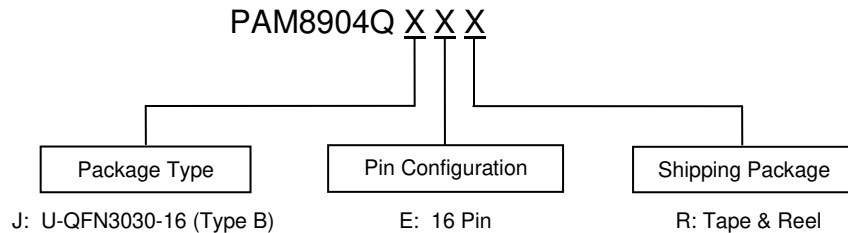

Part Number	Package Code	Package Type (Notes 6 & 7)	7" Tape and Reel		Qualification (Note 8)
			Quantity	Part Number Suffix	
PAM8904QJER	J	U-QFN3030-16 (Type B)	3,000/Tape & Reel	R	Automotive Compliant

- Notes:
6. Pad layout shown at <http://www.diodes.com/package-outlines.html>.
 7. For Tape and reel information see http://www.diodes.com/_files/datasheets/ap02007.pdf.
 8. PAM8904Q has been qualified to AEC-Q100 grade 2 and is classified as "Automotive Compliant" supporting PPAP documentation. Automotive, AEC-Q100 and standard products are electrically and thermally the same, except where specified. For more information, please refer to http://www.diodes.com/product_compliance_definitions.html. See PAM8904 datasheet for commercial qualified versions.

Marking Information

U-QFN3030-16 (Type B)

(Top View)

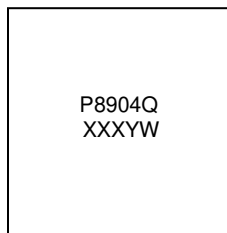

P8904Q: Product Code
 XXX: Internal Code
 Y: Year 0-9
 W: Week: A~Z: 1~26 weeks;
 a~z: 27~52 weeks;
 z represents 52 and 53 weeks

Package Outline Dimensions

Please see <http://www.diodes.com/package-outlines.html> for the latest version.

U-QFN3030-16 (Type B)

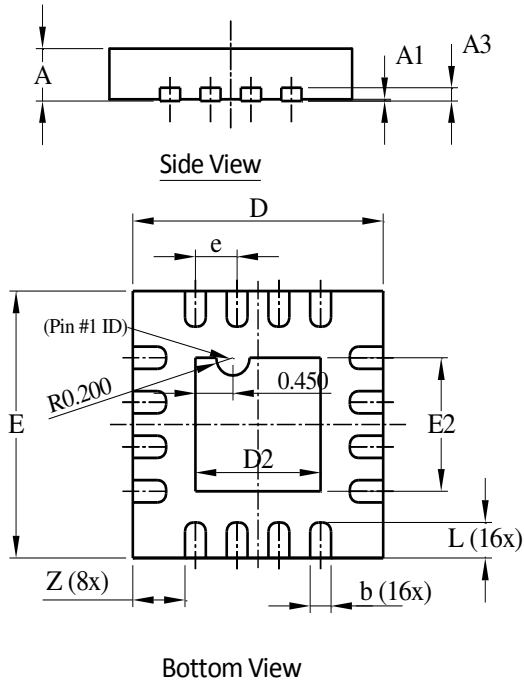

U-QFN3030-16 (Type B)			
Dim	Min	Max	Typ
A	0.55	0.65	0.60
A1	0	0.05	0.02
A3	—	—	0.15
b	0.18	0.28	0.23
D	2.95	3.05	3.00
D2	1.40	1.60	1.50
E	2.95	3.05	3.00
E2	1.40	1.60	1.50
e	—	—	0.50
L	0.35	0.45	0.40
Z	—	—	0.625
All Dimensions in mm			

Suggested Pad Layout

Please see <http://www.diodes.com/package-outlines.html> for the latest version.

U-QFN3030-16 (Type B)

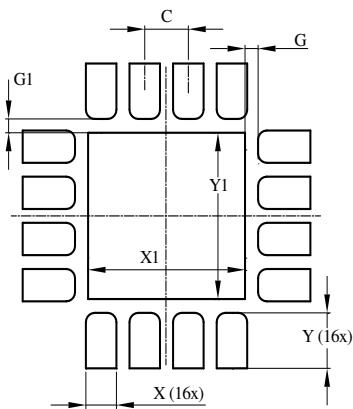

Dimensions	Value (in mm)
C	0.500
G	0.150
G1	0.150
X	0.350
X1	1.800
Y	0.600
Y1	1.800

IMPORTANT NOTICE

DIODES INCORPORATED MAKES NO WARRANTY OF ANY KIND, EXPRESS OR IMPLIED, WITH REGARDS TO THIS DOCUMENT, INCLUDING, BUT NOT LIMITED TO, THE IMPLIED WARRANTIES OF MERCHANTABILITY AND FITNESS FOR A PARTICULAR PURPOSE (AND THEIR EQUIVALENTS UNDER THE LAWS OF ANY JURISDICTION).

Diodes Incorporated and its subsidiaries reserve the right to make modifications, enhancements, improvements, corrections or other changes without further notice to this document and any product described herein. Diodes Incorporated does not assume any liability arising out of the application or use of this document or any product described herein; neither does Diodes Incorporated convey any license under its patent or trademark rights, nor the rights of others. Any Customer or user of this document or products described herein in such applications shall assume all risks of such use and will agree to hold Diodes Incorporated and all the companies whose products are represented on Diodes Incorporated website, harmless against all damages.

Diodes Incorporated does not warrant or accept any liability whatsoever in respect of any products purchased through unauthorized sales channel. Should Customers purchase or use Diodes Incorporated products for any unintended or unauthorized application, Customers shall indemnify and hold Diodes Incorporated and its representatives harmless against all claims, damages, expenses, and attorney fees arising out of, directly or indirectly, any claim of personal injury or death associated with such unintended or unauthorized application.

Products described herein may be covered by one or more United States, international or foreign patents pending. Product names and markings noted herein may also be covered by one or more United States, international or foreign trademarks.

This document is written in English but may be translated into multiple languages for reference. Only the English version of this document is the final and determinative format released by Diodes Incorporated.

LIFE SUPPORT

Diodes Incorporated products are specifically not authorized for use as critical components in life support devices or systems without the express written approval of the Chief Executive Officer of Diodes Incorporated. As used herein:

A. Life support devices or systems are devices or systems which:

1. are intended to implant into the body, or
2. support or sustain life and whose failure to perform when properly used in accordance with instructions for use provided in the labeling can be reasonably expected to result in significant injury to the user.

B. A critical component is any component in a life support device or system whose failure to perform can be reasonably expected to cause the failure of the life support device or to affect its safety or effectiveness.

Customers represent that they have all necessary expertise in the safety and regulatory ramifications of their life support devices or systems, and acknowledge and agree that they are solely responsible for all legal, regulatory and safety-related requirements concerning their products and any use of Diodes Incorporated products in such safety-critical, life support devices or systems, notwithstanding any devices- or systems-related information or support that may be provided by Diodes Incorporated. Further, Customers must fully indemnify Diodes Incorporated and its representatives against any damages arising out of the use of Diodes Incorporated products in such safety-critical, life support devices or systems.

Copyright © 2016, Diodes Incorporated

www.diodes.com