



Chipsmall Limited consists of a professional team with an average of over 10 year of expertise in the distribution of electronic components. Based in Hongkong, we have already established firm and mutual-benefit business relationships with customers from,Europe,America and south Asia,supplying obsolete and hard-to-find components to meet their specific needs.

With the principle of “Quality Parts,Customers Priority,Honest Operation,and Considerate Service”,our business mainly focus on the distribution of electronic components. Line cards we deal with include Microchip,ALPS,ROHM,Xilinx,Pulse,ON,Everlight and Freescale. Main products comprise IC,Modules,Potentiometer,IC Socket,Relay,Connector.Our parts cover such applications as commercial,industrial, and automotives areas.

We are looking forward to setting up business relationship with you and hope to provide you with the best service and solution. Let us make a better world for our industry!



Contact us

Tel: +86-755-8981 8866 Fax: +86-755-8427 6832

Email & Skype: info@chipsmall.com Web: www.chipsmall.com

Address: A1208, Overseas Decoration Building, #122 Zhenhua RD., Futian, Shenzhen, China



Positive voltage regulator for battery charger

Features

- Reverse leakage current less than 10 μA
- Three terminal fixed version (13.7 V) output current in excess of 1.5 A
- Available in $\pm 1\%$ (AC) selection at 25 $^{\circ}\text{C}$
- Typical dropout voltage 2 V
- Temperature range 0 to 150 $^{\circ}\text{C}$

Description

The PB137 is a positive voltage regulator able to provide 1.5 A, at $V_{\text{O}} = 13.7\text{ V}$ and is intended as a charger for lead acid battery. The main feature is a reverse leakage current (Max 10 μA at $T_{\text{J}} = 0$ to 40 $^{\circ}\text{C}$ $V_{\text{I}} = \text{floating}$ and $V_{\text{O}} = 13.7\text{ V}$). It is available in TO-220 and it employs internal current limiting, thermal shut-down and safe area protection, making it essentially indestructible. If adequate heat-sinking is provided, they can deliver over 1 A output current.

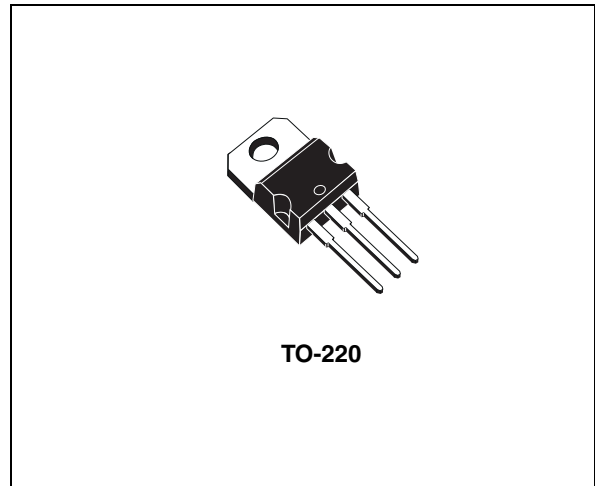

Table 1. Device summary

Order code	Package	Output voltage
PB137ACV	TO-220	1.5 V

Contents

1	Diagram	3
2	Pin configuration	4
3	Application	5
4	Maximum ratings	6
5	Electrical characteristics	7
6	Typical characteristics	8
7	Package mechanical data	11
8	Revision history	13

1 Diagram

Figure 1. Schematic diagram

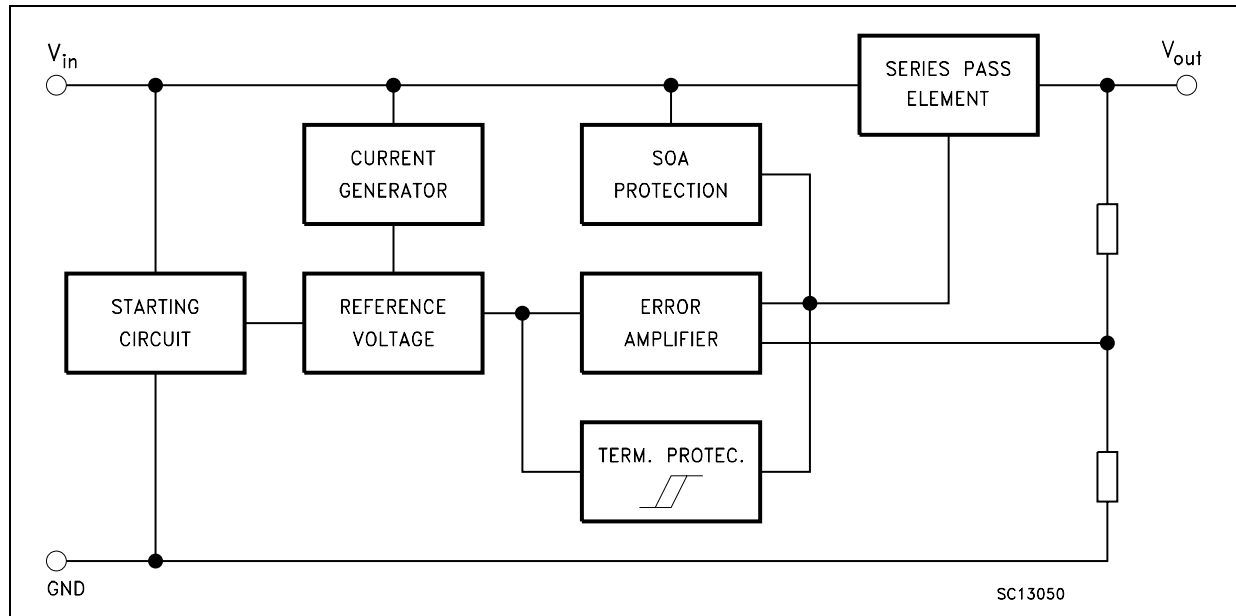

2 Pin configuration

Figure 2. Pin connections (top view)

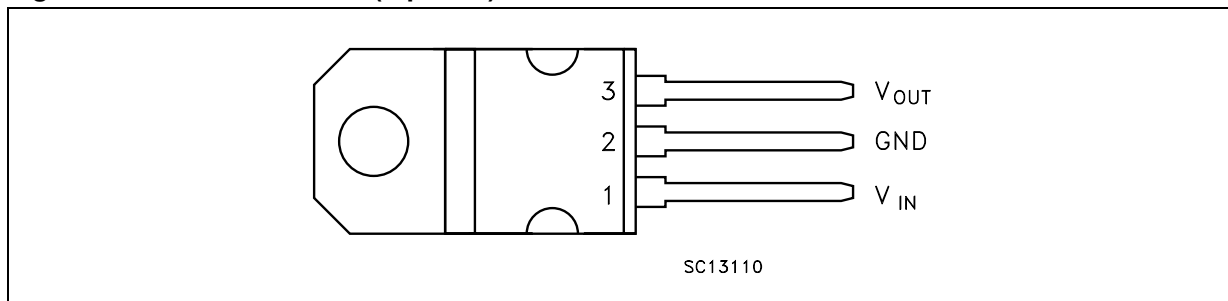

3 Application

Figure 3. Application circuit

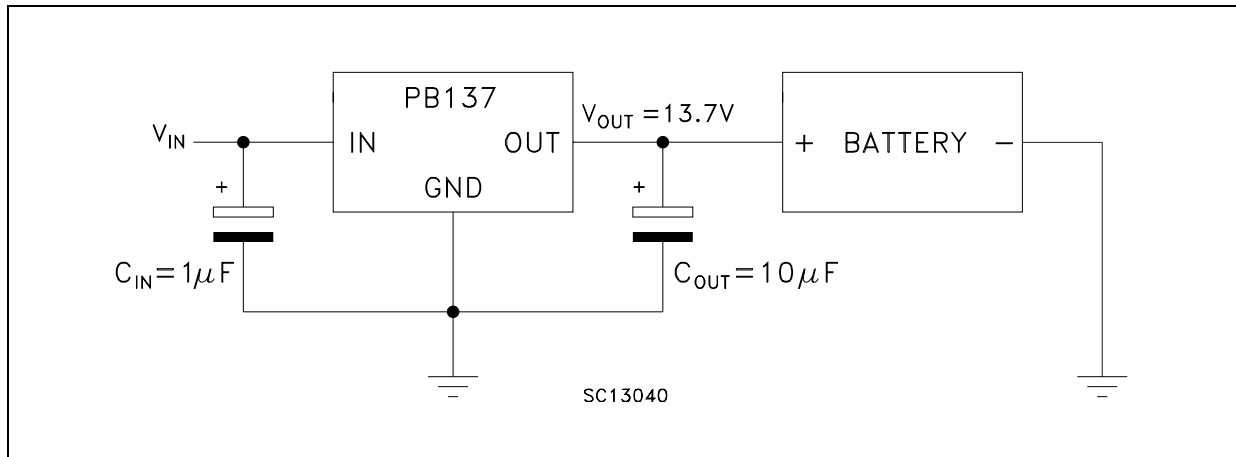

4 Maximum ratings

Table 2. Absolute maximum ratings

Symbol	Parameter	Value	Unit
V_I	DC input voltage	40	V
I_O	Output current	Internally limited	mA
P_{TOT}	Power dissipation	Internally limited	mW
T_{STG}	Storage temperature range	- 65 to 150	°C
T_{OP}	Operating junction temperature range	0 to 150	°C

Note: Absolute maximum ratings are those values beyond which damage to the device may occur. Functional operation under these condition is not implied.

Table 3. Thermal data

Symbol	Parameter	Value	Unit
R_{thJC}	Thermal resistance junction-case	5	°C/W
R_{thJA}	Thermal resistance junction-ambient	50	°C/W

5 Electrical characteristics

Refer to the test circuits, $V_I = 18\text{ V}$, $I_O = 500\text{ mA}$, $T_J = 0\text{ to }150\text{ }^\circ\text{C}$, $C_O = 10\text{ }\mu\text{F}$ unless otherwise specified.

Table 4. Electrical characteristics

Symbol	Parameter	Test conditions	Min.	Typ.	Max.	Unit
V_O	Output voltage	$T_J = 25\text{ }^\circ\text{C}$	13.56	13.7	13.84	V
			13.43	13.7	13.97	
ΔV_O	Line regulation	$V_I = 16\text{ to }28.7\text{ V}$, $T_J = 25\text{ }^\circ\text{C}$		60	150	mV
ΔV_O	Load regulation	$I_O = 5\text{ to }1500\text{ mA}$, $T_J = 25\text{ }^\circ\text{C}$		65	100	mV
I_d	Quiescent current	$T_J = 25\text{ }^\circ\text{C}$		4	8	mA
ΔI_d	Delta quiescent current vs. line	$V_I = 16\text{ to }28.7\text{ V}$			4	mA
ΔI_d	Delta quiescent current vs. load	$I_O = 5\text{ to }1000\text{ mA}$			1.2	mA
V_d	Dropout voltage	$I_O = 1\text{ A}$, $T_J = 25\text{ }^\circ\text{C}$		2.1	2.6	V
I_{sc}	Short circuit current	$V_I - V_O = 5\text{ V}$, $T_J = 25\text{ }^\circ\text{C}$		2.2		A
eN	Output noise voltage	$B = 10\text{ Hz to }10\text{ kHz}$, $T_J = 25\text{ }^\circ\text{C}$		300		μVrms
SVR	Supply voltage rejection	$f = 120\text{ Hz}$, $T_J = 25\text{ }^\circ\text{C}$		58		dB
I_{REV}	Reverse leakage current	$V_O = 13.7\text{ V}$, $V_I = \text{floating}$, $T_J = 0\text{ to }40\text{ }^\circ\text{C}$		0.1	10	μA
S	Long term stability	$T_J = 125\text{ }^\circ\text{C}$, 1000 Hrs			0.5	%

6 Typical characteristics

$T_J = 25^\circ\text{C}$.

Figure 4. Output voltage vs. temperature

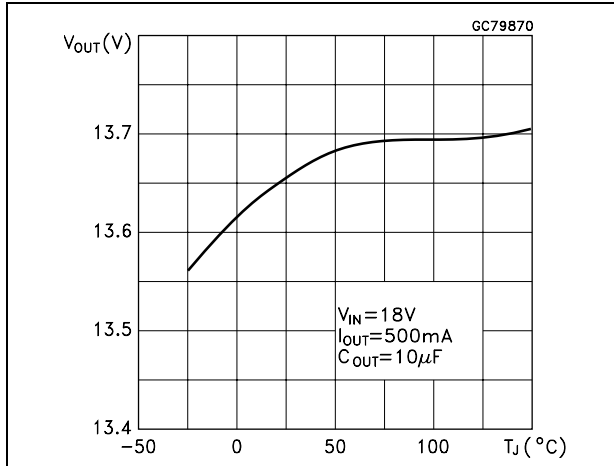

Figure 5. Output voltage vs. input voltage

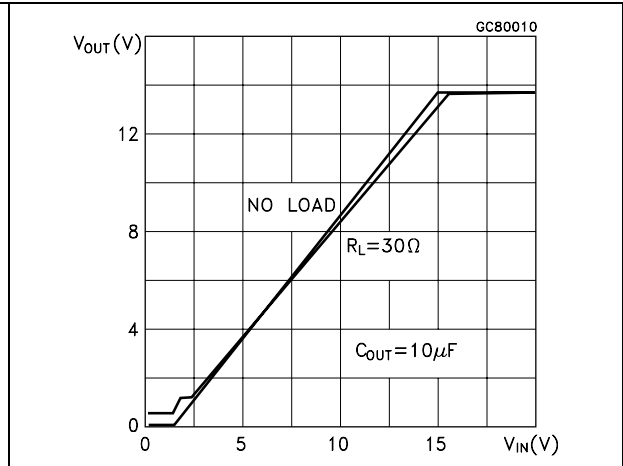

Figure 6. Output voltage vs. output current

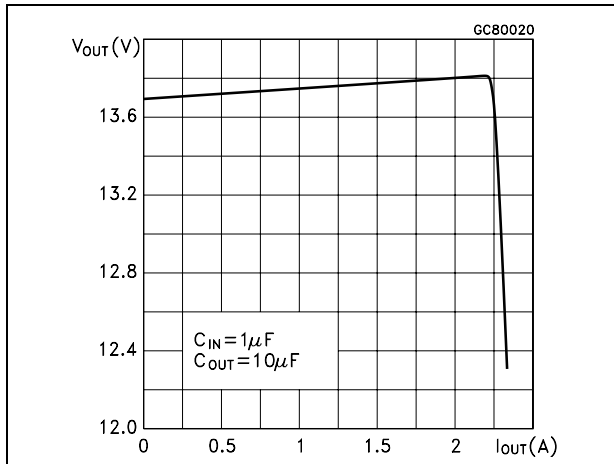

Figure 7. Load regulation vs. temperature

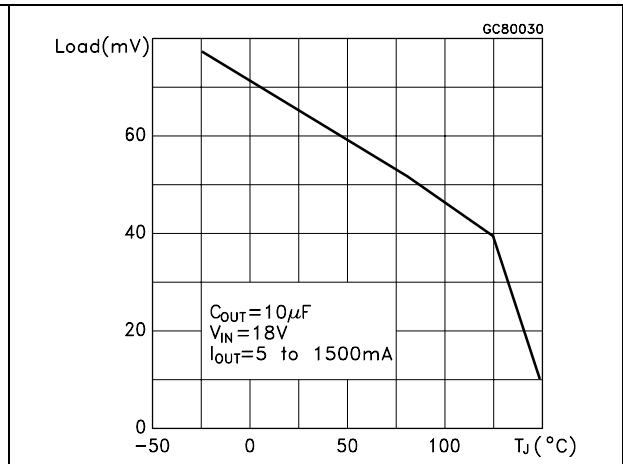

Figure 8. Line regulation vs. temperature

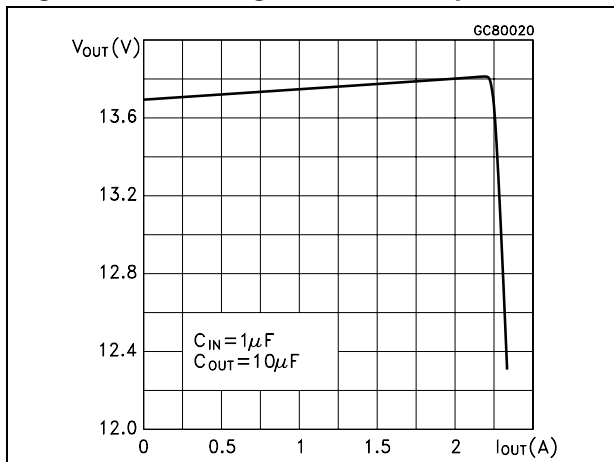

Figure 9. Dropout voltage vs. temperature

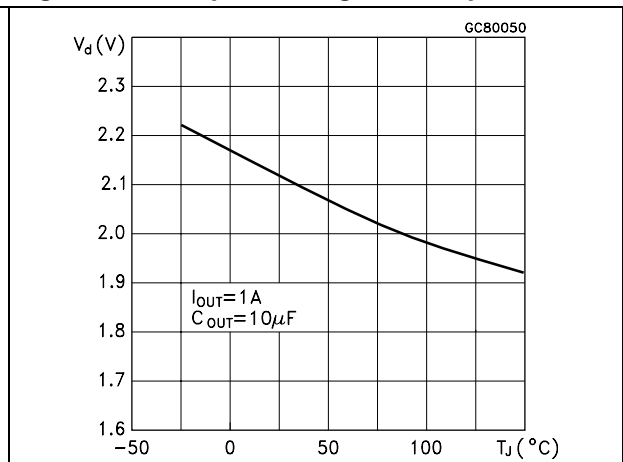

Figure 10. Dropout voltage vs. output current

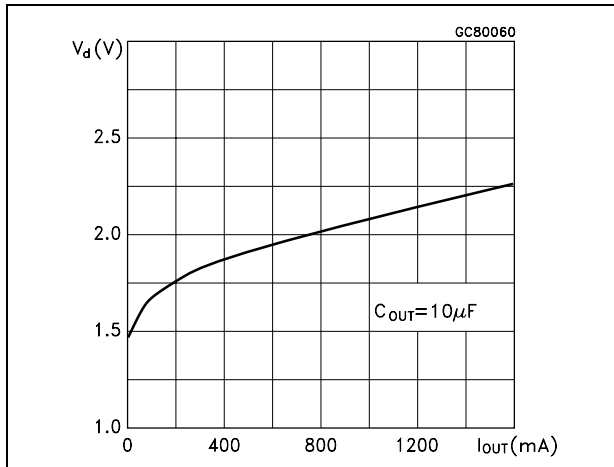

Figure 11. Short circuit current vs. dropout voltage

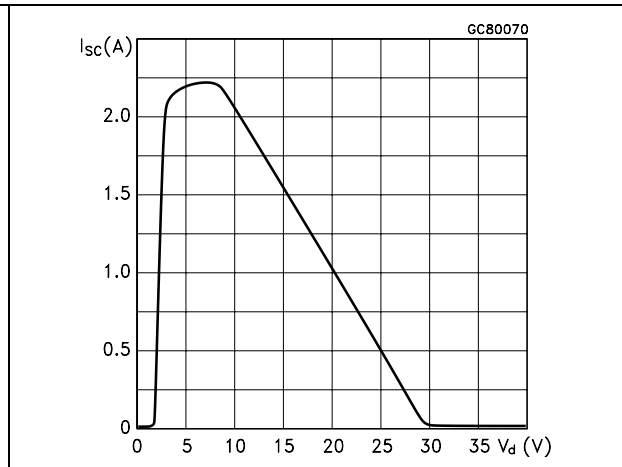

Figure 12. Short circuit current vs. temperature

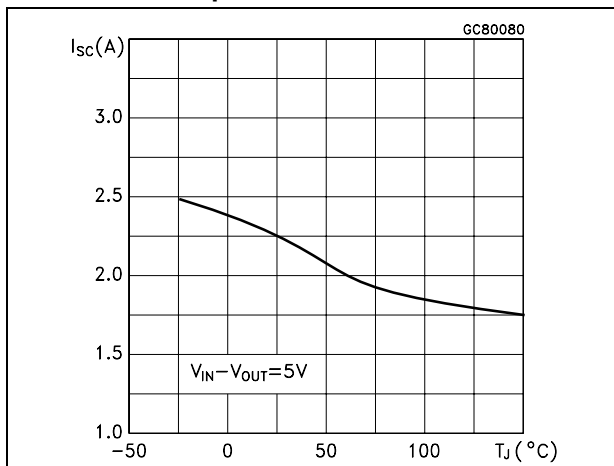

Figure 13. Reverse leakage current vs. temperature

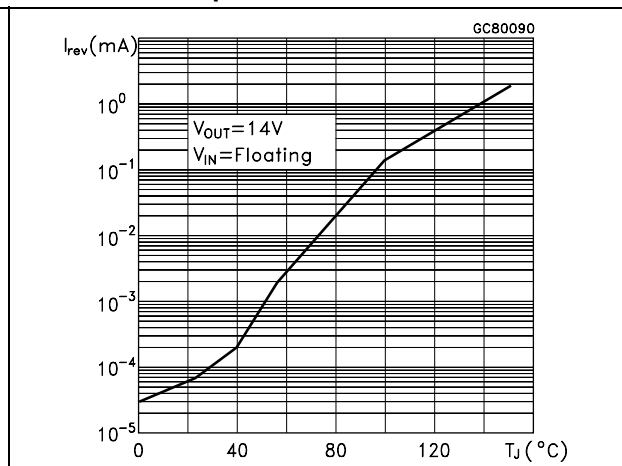

Figure 14. Quiescent current vs. temperature

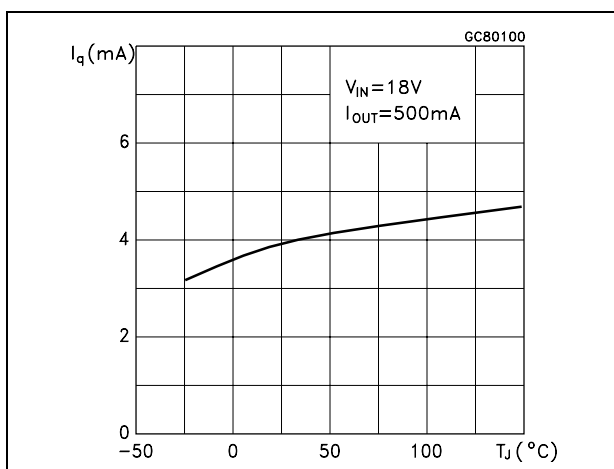

Figure 15. Quiescent current vs. output current

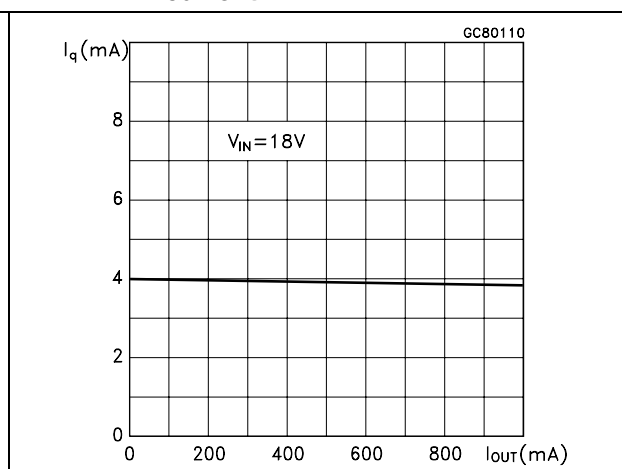

Figure 16. Quiescent current vs. input voltage Figure 17. Thermal protection

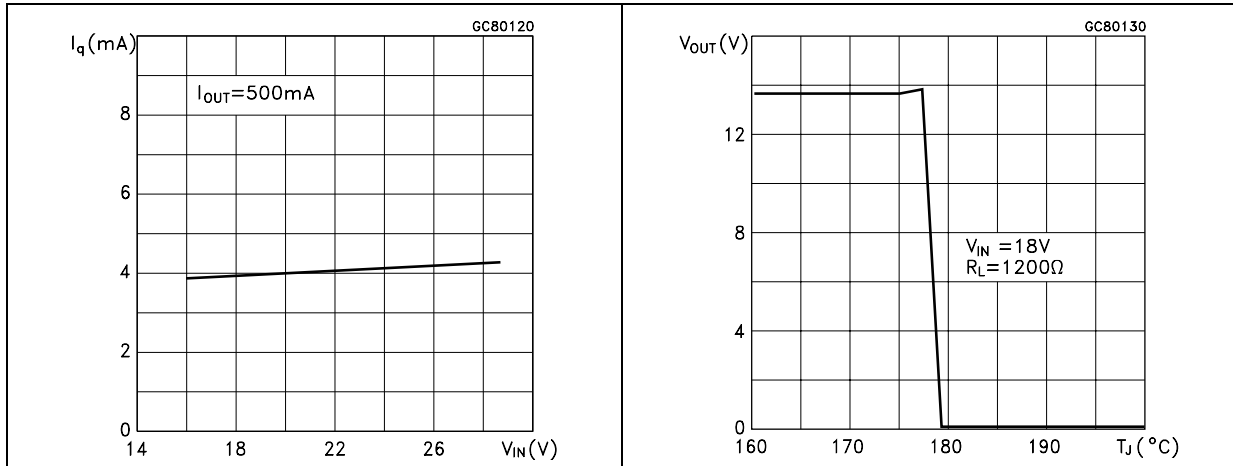

Figure 18. Supply voltage rejection vs. output current Figure 19. Supply voltage rejection vs. temperature

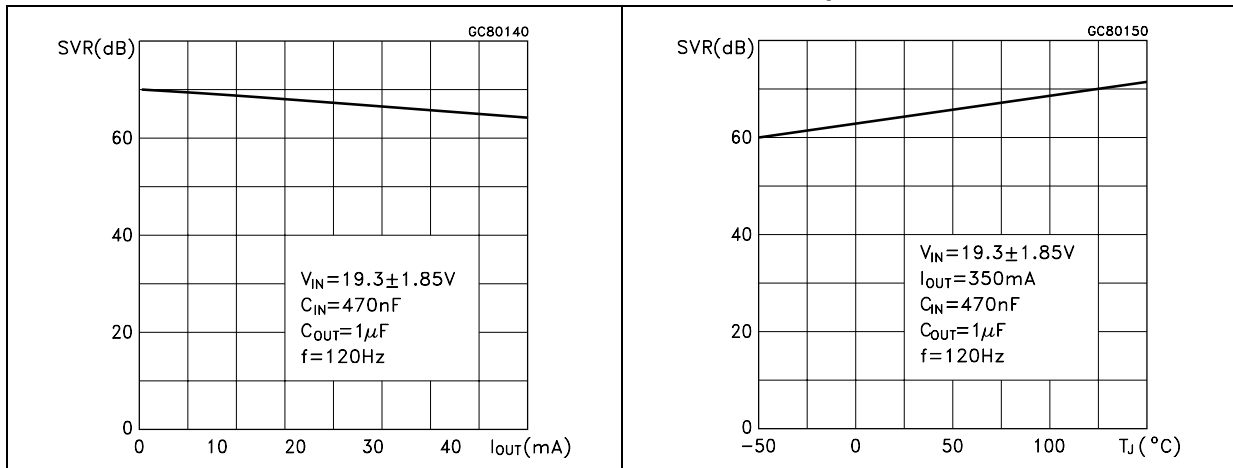
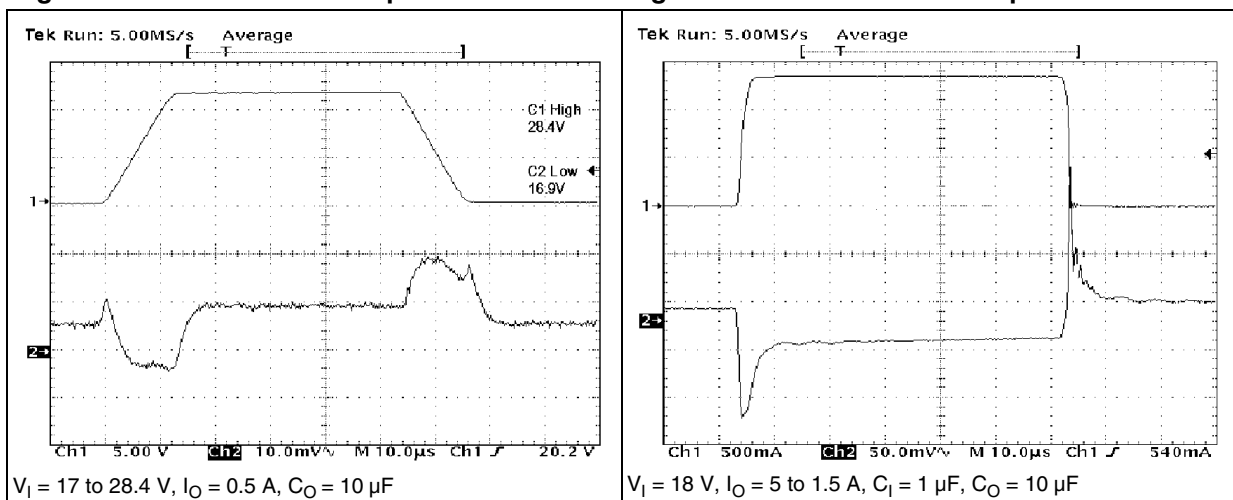

Figure 20. Line transient response Figure 21. Load transient response



7 Package mechanical data

In order to meet environmental requirements, ST offers these devices in different grades of ECOPACK[®] packages, depending on their level of environmental compliance. ECOPACK[®] specifications, grade definitions and product status are available at: www.st.com. ECOPACK[®] is an ST trademark.

TO-220 mechanical data

Dim.	mm.			inch.		
	Min.	Typ.	Max.	Min.	Typ.	Max.
A	4.40		4.60	0.173		0.181
C	1.23		1.32	0.048		0.051
D	2.40		2.72	0.094		0.107
D1		1.27			0.050	
E	0.49		0.70	0.019		0.027
F	0.61		0.88	0.024		0.034
F1	1.14		1.70	0.044		0.067
F2	1.14		1.70	0.044		0.067
G	4.95		5.15	0.194		0.203
G1	2.4		2.7	0.094		0.106
H2	10.0		10.40	0.393		0.409
L2		16.4			0.645	
L4	13.0		14.0	0.511		0.551
L5	2.65		2.95	0.104		0.116
L6	15.25		15.75	0.600		0.620
L7	6.2		6.6	0.244		0.260
L9	3.5		3.93	0.137		0.154
DIA.	3.75		3.85	0.147		0.151

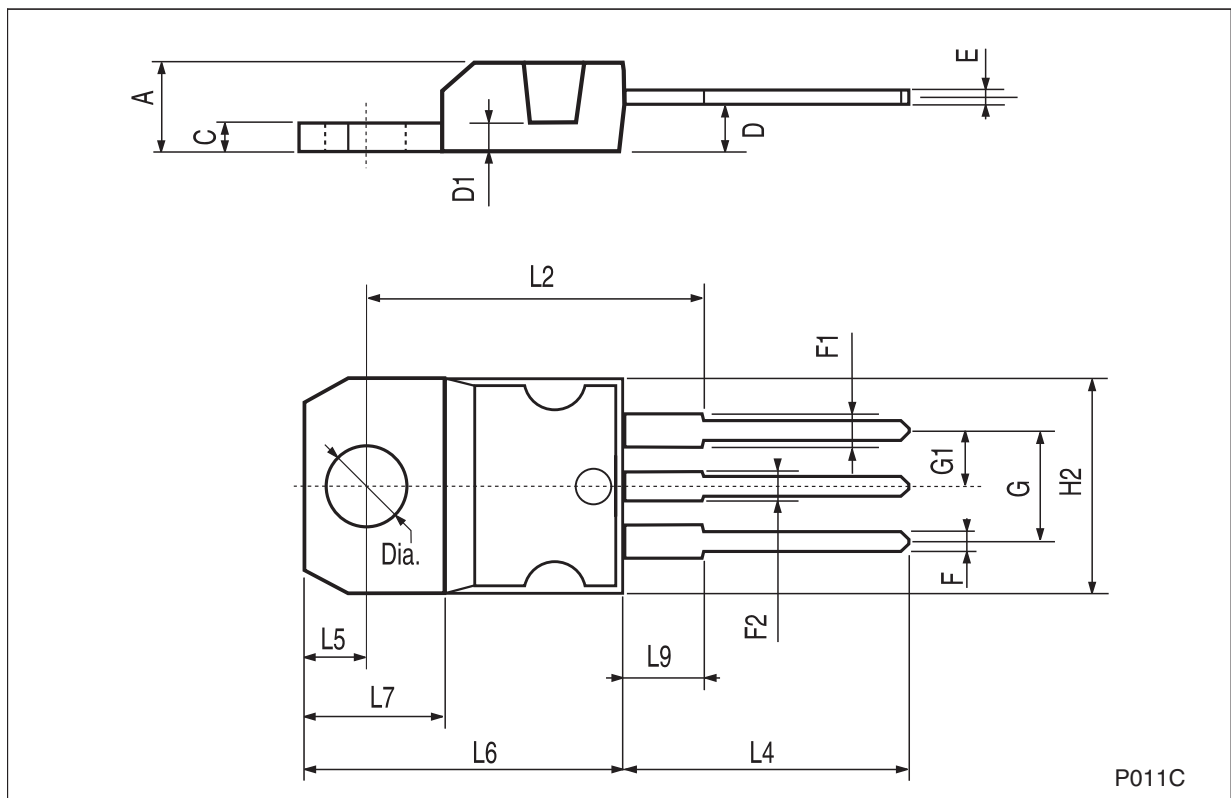

8 Revision history

Table 5. Document revision history

Date	Revision	Changes
21-Jun-2004	4	
18-Nov-2010	5	Modified: R_{thJC} value for TO-220 Table 3 on page 6 .

Please Read Carefully:

Information in this document is provided solely in connection with ST products. STMicroelectronics NV and its subsidiaries ("ST") reserve the right to make changes, corrections, modifications or improvements, to this document, and the products and services described herein at any time, without notice.

All ST products are sold pursuant to ST's terms and conditions of sale.

Purchasers are solely responsible for the choice, selection and use of the ST products and services described herein, and ST assumes no liability whatsoever relating to the choice, selection or use of the ST products and services described herein.

No license, express or implied, by estoppel or otherwise, to any intellectual property rights is granted under this document. If any part of this document refers to any third party products or services it shall not be deemed a license grant by ST for the use of such third party products or services, or any intellectual property contained therein or considered as a warranty covering the use in any manner whatsoever of such third party products or services or any intellectual property contained therein.

UNLESS OTHERWISE SET FORTH IN ST'S TERMS AND CONDITIONS OF SALE ST DISCLAIMS ANY EXPRESS OR IMPLIED WARRANTY WITH RESPECT TO THE USE AND/OR SALE OF ST PRODUCTS INCLUDING WITHOUT LIMITATION IMPLIED WARRANTIES OF MERCHANTABILITY, FITNESS FOR A PARTICULAR PURPOSE (AND THEIR EQUIVALENTS UNDER THE LAWS OF ANY JURISDICTION), OR INFRINGEMENT OF ANY PATENT, COPYRIGHT OR OTHER INTELLECTUAL PROPERTY RIGHT.

UNLESS EXPRESSLY APPROVED IN WRITING BY AN AUTHORIZED ST REPRESENTATIVE, ST PRODUCTS ARE NOT RECOMMENDED, AUTHORIZED OR WARRANTED FOR USE IN MILITARY, AIR CRAFT, SPACE, LIFE SAVING, OR LIFE SUSTAINING APPLICATIONS, NOR IN PRODUCTS OR SYSTEMS WHERE FAILURE OR MALFUNCTION MAY RESULT IN PERSONAL INJURY, DEATH, OR SEVERE PROPERTY OR ENVIRONMENTAL DAMAGE. ST PRODUCTS WHICH ARE NOT SPECIFIED AS "AUTOMOTIVE GRADE" MAY ONLY BE USED IN AUTOMOTIVE APPLICATIONS AT USER'S OWN RISK.

Resale of ST products with provisions different from the statements and/or technical features set forth in this document shall immediately void any warranty granted by ST for the ST product or service described herein and shall not create or extend in any manner whatsoever, any liability of ST.

ST and the ST logo are trademarks or registered trademarks of ST in various countries.

Information in this document supersedes and replaces all information previously supplied.

The ST logo is a registered trademark of STMicroelectronics. All other names are the property of their respective owners.

© 2010 STMicroelectronics - All rights reserved

STMicroelectronics group of companies

Australia - Belgium - Brazil - Canada - China - Czech Republic - Finland - France - Germany - Hong Kong - India - Israel - Italy - Japan - Malaysia - Malta - Morocco - Philippines - Singapore - Spain - Sweden - Switzerland - United Kingdom - United States of America

www.st.com