



Chipsmall Limited consists of a professional team with an average of over 10 year of expertise in the distribution of electronic components. Based in Hongkong, we have already established firm and mutual-benefit business relationships with customers from,Europe,America and south Asia,supplying obsolete and hard-to-find components to meet their specific needs.

With the principle of “Quality Parts,Customers Priority,Honest Operation,and Considerate Service”,our business mainly focus on the distribution of electronic components. Line cards we deal with include Microchip,ALPS,ROHM,Xilinx,Pulse,ON,Everlight and Freescale. Main products comprise IC,Modules,Potentiometer,IC Socket,Relay,Connector.Our parts cover such applications as commercial,industrial, and automotives areas.

We are looking forward to setting up business relationship with you and hope to provide you with the best service and solution. Let us make a better world for our industry!



Contact us

Tel: +86-755-8981 8866 Fax: +86-755-8427 6832

Email & Skype: info@chipsmall.com Web: www.chipsmall.com

Address: A1208, Overseas Decoration Building, #122 Zhenhua RD., Futian, Shenzhen, China



Formed & Knockdown Wall Racks

FWB, HPB & VPB Series

FWB Series - Economy Fixed Wall Bracket

- Hinged for easy rear access to devices.
- Fixed-depth of 6".
- 16 gauge formed steel.
- Rear cable access.
- Black powder paint finish.
- Static weight-load tested up to 70 lbs.
- Includes four (4) 10-32 black rack screws w/washers and clip nuts per rack unit.

Part No.	Description	Contractor Pack
FWB191UBK	1U Wall Bracket	FWB191UBK-12
FWB192UBK	2U Wall Bracket	FWB192UBK-12
FWB194UBK	4U Wall Bracket	FWB194UBK-12

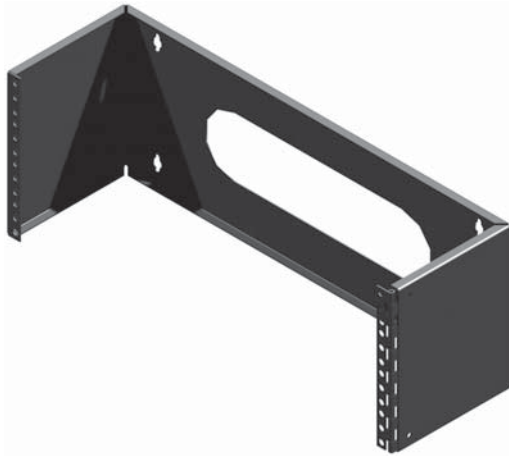

HPB Series - Heavy Duty Fixed Wall Bracket

- Knock-down design.
- Ships un-assembled (flat-pack).
- 14 gauge formed steel.
- Hinged for easy rear access to devices.
- Fixed-depth of 6".
- Multiple tie points for cable management.
- EIA compliant 10-32 tapped holes.
- Static weight-load tested up to 90 lbs.
- Black powder paint finish.

Part No.	Description
HPB19003BK1	2U Wall Bracket
HPB19005BK1	3U Wall Bracket
HPB19007BK1	4U Wall Bracket
PBCOVER	6" Depth Dust cover/shelf

Includes 10 or 25-pack of 10-32 black rack screws w/washers and mounting template for easy installation.

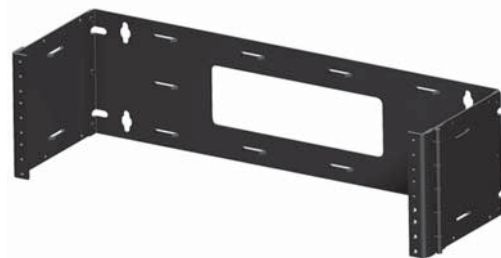

VPB Series - Heavy Duty Vertical Wall Bracket

- Available in 2U, 4U and 6U mounting depths.
- Includes generous rear cutout for cable entry.
- Four (4) wall mount keyholes included.
- 14-gauge formed construction.
- EIA compliant punched hole mounting rails are stronger than square holes.
 - Uses 10-32 clip nuts (includes starter pack of 10-32 clip nuts and screws).
- Recommended weight load tested for 135 lbs.
- Rugged textured black powder paint.

Part #	Panel Height		Overall Dimensions		
	Inches	Units	Height	Width	Depth
VPB192UBK	3.50	2	7.69"	19.19"	4.19"
VPB194UBK	7.00	4	7.96"	19.19"	7.69"
VPB196UBK	10.50	6	11.19"	19.19"	11.19"

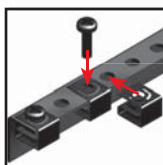
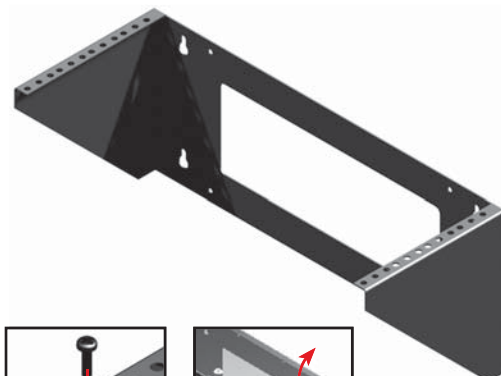

Clip nuts are easier to install when compared to square hole cage nuts.

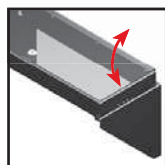

Optional acrylic RMSC hinged panel cover prevents equipment from dust and tampering.

Data Communication Infrastructure

Technical references and CAD downloads available at www.hammondmfg.com

All dimensions in inches unless specified otherwise

Formed & Knockdown Wall Racks

FWB, HPB & VPB Series

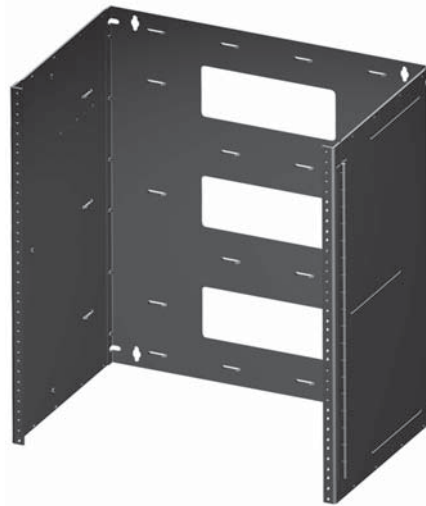

APB Series - Heavy Duty Adjustable Wall Bracket

- Knock-down design ships un-assembled (flat-pack).
- Mounting heights available in 4U, 6U, 8U and 12U.
- Available in two depths, from 12" to 18" using slots for easy set-up and adjusting.
- Includes generous rear cutout for cable entry.
- Four (4) wall mount keyholes included.
- Double-hinged for easy rear access.
- Multiple tie points for cable management.
- EIA compliant 10-32 tapped mounting rails.
 - Includes starter pack of 10-32 screws.
- Constructed of 14 gauge formed steel with a recommended weight load of 80 lbs.
- Professional smooth black powder paint.

Part #	Panel Dimensions		Overall Dimensions		
	Height	Units	Height	Width	Depth
APB19007BK1	7.00	4	6.98"	19.25"	12" - 18"
APB19010BK1	10.50	6	10.48"	19.25"	12" - 18"
APB19014BK1	14.00	8	13.98"	19.25"	12" - 18"
APB19021BK1	21.00	12	20.98"	19.25"	12" - 18"

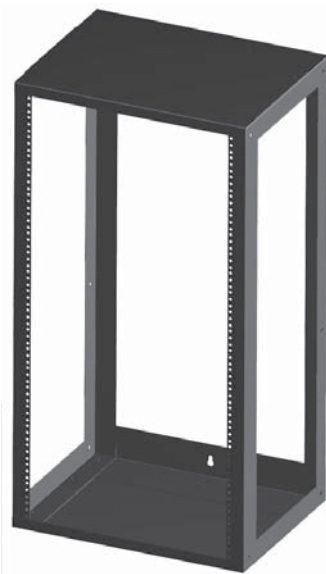

1459 Series - Open Frame

- EIA compliant 10-32 clip nuts mounting rails.
- Suitable for wall or table mounting (with open back).
- Removable top & bottom panels included.
- Four (4) wall mount keyholes included.
- Optional side panels sold separately.
- Comes with rubber feet for table mounting.
- Constructed of 16 gauge formed steel with a recommended weight load of 800 lbs.
- Rugged textured black powder paint finish.

Part #	Panel Dimensions		Overall Dimensions			Side Panels (Sold in Pairs)
	Height	Units	Height	Width	Depth	
1459FBK1	22.75	13	21.12"	24.7"	16.14"	1459FQBK1
1459JBK1	33.25	19	21.12"	35.2"	16.14"	1459JQBK1
1459MBK1	47.25	27	21.12"	49.2"	16.14"	1459MQBK1