



Chipsmall Limited consists of a professional team with an average of over 10 year of expertise in the distribution of electronic components. Based in Hongkong, we have already established firm and mutual-benefit business relationships with customers from,Europe,America and south Asia,supplying obsolete and hard-to-find components to meet their specific needs.

With the principle of “Quality Parts,Customers Priority,Honest Operation,and Considerate Service”,our business mainly focus on the distribution of electronic components. Line cards we deal with include Microchip,ALPS,ROHM,Xilinx,Pulse,ON,Everlight and Freescale. Main products comprise IC,Modules,Potentiometer,IC Socket,Relay,Connector.Our parts cover such applications as commercial,industrial, and automotives areas.

We are looking forward to setting up business relationship with you and hope to provide you with the best service and solution. Let us make a better world for our industry!



Contact us

Tel: +86-755-8981 8866 Fax: +86-755-8427 6832

Email & Skype: info@chipsmall.com Web: www.chipsmall.com

Address: A1208, Overseas Decoration Building, #122 Zhenhua RD., Futian, Shenzhen, China



FlexiSLIC™

Subscriber Line Interface Circuit

PBL 38640/2, Version 2

Wireline Communications



Never stop thinking.

ABM[®], ACE[®], AOP[®], ARCOFI[®], ASM[®], ASP[®], DigiTape[®], DuSLIC[®], EPIC[®], ELIC[®], FALC[®], GEMINAX[®], IDEC[®], INCA[®], IOM[®], IPAT[®]-2, ISAC[®], ITAC[®], IWE[®], IWORX[®], MUSAC[®], MuSLIC[®], OCTAT[®], OptiPort[®], POTSWIRE[®], QUAT[®], QuadFALC[®], SCOUT[®], SICAT[®], SICOFI[®], SIDEC[®], SLICOFI[®], SMINT[®], SOCRATES[®], VINETIC[®], 10BaseV[®], 10BaseVX[®] are registered trademarks of Infineon Technologies AG. 10BaseS[™], EasyPort[™], FlexiSLIC[™], VDSLite[™] are trademarks of Infineon Technologies AG. Microsoft[®] is a registered trademark of Microsoft Corporation, Linux[®] of Linus Torvalds, Visio[®] of Visio Corporation, and FrameMaker[®] of Adobe Systems Incorporated.

The information in this document is subject to change without notice.

Edition 2005-04-14

**Published by Infineon Technologies AG,
St.-Martin-Strasse 53,
81669 München, Germany**

**© Infineon Technologies AG 2005.
All Rights Reserved.**

Attention please!

The information herein is given to describe certain components and shall not be considered as a guarantee of characteristics.

Terms of delivery and rights to technical change reserved.

We hereby disclaim any and all warranties, including but not limited to warranties of non-infringement, regarding circuits, descriptions and charts stated herein.

Information

For further information on technology, delivery terms and conditions and prices please contact your nearest Infineon Technologies Office (www.infineon.com).

Warnings

Due to technical requirements components may contain dangerous substances. For information on the types in question please contact your nearest Infineon Technologies Office.

Infineon Technologies Components may only be used in life-support devices or systems with the express written approval of Infineon Technologies, if a failure of such components can reasonably be expected to cause the failure of that life-support device or system, or to affect the safety or effectiveness of that device or system. Life support devices or systems are intended to be implanted in the human body, or to support and/or maintain and sustain

FlexiSLIC**Revision History:** **2005-04-14**

Rev. 2.0

Previous Version: **DS1**

Page	Subjects (major changes since last revision)
all	Package P-DSO-24-1 changed to P-/PG-DSO-24-8
all	Package type abbreviation SOIC changed to PDSO
all	Package P-LCC-28-2 changed to P-/PG-LCC-28-3
all	Package P-SSOP-24-1 changed to P-/PG-SSOP-24-1
Page 17	Table 5: Thermal resistance for 24-pin PDSO changed from 80.2 °C/W to 50.3 °C/W
Page 30	Figure 9: SLIC/codec circuitry changed
Page 31	Table 6: values of R_R , R_T , R_{RX} , R_{TX} , R_B changed, R_{FB} removed
Page 36	Figure 11 changed

Table of Contents		Page
1	Overview	8
1.1	Features	8
1.2	Typical Applications	9
1.3	Description	9
1.4	Block Diagram	10
2	Pin Configuration	11
3	Electrical Characteristics	15
3.1	Characteristics	17
4	Application Schematic	30
4.1	Recommended Components	31
4.2	Design Supporting Tools	32
5	Transmission	33
5.1	General	33
5.2	Two-Wire Impedance	34
5.3	Two-Wire to Four-Wire Gain	34
5.4	Four-Wire to Two-Wire Gain	35
5.5	Four-Wire to Four-Wire Gain	35
5.6	Hybrid Function	35
5.7	Longitudinal Impedance	37
5.8	Capacitors C_{TC} and C_{RC}	37
5.9	AC - DC Separation Capacitor, C_{HP}	37
5.10	High-pass Transmit Filter	37
5.11	Capacitor C_{LP}	37
6	Battery Feed	38
6.1	CODEC Receive Interface	39
6.2	Programmable Overhead Voltage (POV)	43
6.3	Analog Temperature Guard	44
7	Loop Monitoring Functions	44
7.1	Loop Current Detector	44
7.2	Ground Key Detector	44
7.3	Ring Trip Detector	44
8	Relay Driver	45
9	Control Inputs	45
9.1	Open Circuit ($C3, C2, C1 = 0, 0, 0$)	45
9.2	Ringing ($C3, C2, C1 = 0, 0, 1$)	46
9.3	Active States	46
9.4	Tip Open State	46
9.5	Active Polarity Reversal State	46

Table of Contents		Page
10	Overvoltage Protection	46
10.1	Overvoltage Protection - General	46
10.2	Secondary Protection	47
11	Power-Up Sequence	47
12	Printed Circuit Board Layout	47
13	Package Outlines	48
13.1	24-pin SSOP Package	48
13.2	24-pin PDSO Package	49
13.3	28-pin PLCC Package	50

List of Figures	Page
Figure 1	Block Diagram 10
Figure 2	Pin Configuration, 24L-PDSO, 24L-SSOP and 28L-PLCC (top view) . 11
Figure 3	Overhead Level, V_{TRO} , Two-Wire Port 27
Figure 4	Longit. to Metallic, B_{LME} and Longit. to Four-Wire, B_{LFE} Balance 28
Figure 5	Metallic to Longit., B_{MLE} and Four-Wire to Longit. Balance, B_{FLE} 28
Figure 6	Overhead Level, V_{TXO} , Four-Wire Transmit Port 28
Figure 7	Frequency Response, Insertion Loss, Gain Tracking 29
Figure 8	TIPX Voltage 29
Figure 9	Application Example of PBL 38640/2 with SICOFI [®] 4 Codec 30
Figure 10	Simplified AC Model of PBL 38640/2 33
Figure 11	Hybrid Function 36
Figure 12	Codec Receive Interface 40
Figure 13	Battery Feed Characteristics 41
Figure 14	Programmable Overhead Voltage (POV). $R_L = 600 \Omega$ or Infinite 43
Figure 15	P-/PG-SSOP-24-1 (Plastic Shrink Small Outline Package) 48
Figure 16	P-/PG-DSO-24-8 (Plastic Dual Small Outline Package) 49
Figure 17	P-/PG-LCC-28-3 (Plastic Leaded Chip Carrier Package) 50

List of Tables		Page
Table 1	Pin Definition and Functions	11
Table 2	SLIC Operating States	14
Table 3	Absolute Maximum Ratings	15
Table 4	Operating Range	16
Table 5	Characteristics	17
Table 6	Resistors	31
Table 7	Capacitors	31
Table 8	Diodes	32
Table 9	Feeding Setup	38
Table 10	Battery Overhead	39
Table 11	Internal Bias Current of RSN	40

FlexiSLIC Subscriber Line Interface Circuit

PBL 38640/2

Version 2

1 Overview

1.1 Features

- 24-pin SSOP package
- High and low battery with automatic switching
- 65 mW on-hook power dissipation in active state
- On-hook transmission
- Long loop battery feed tracks Vbat for maximum line voltage
- Selectable transmit gain (1x or 0.5 x)
- No power-up sequence
- 43 V open loop voltage @ -48 V battery feed
- Close tolerance current feeding
- Constant loop voltage for line leakage < 5 mA (RLeak ~ > 10 kΩ @ -48 V)
- Full longitudinal current capability during on-hook state
- Longitudinal balance > 60 dB
- Analog overtemperature protection permits transmission while the protection circuits is active
- Line voltage measurement
- Polarity reversal
- Ground key detector
- Tip open state with ring ground detector
- Programmable signal headroom
- -40 °C to +85 °C ambient temperature range

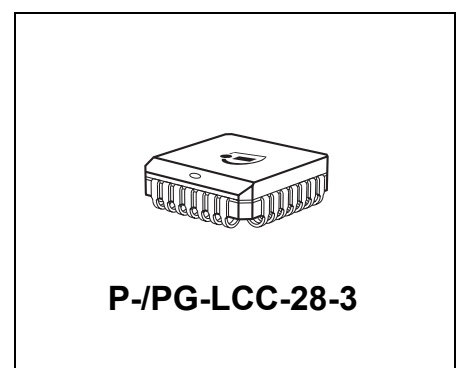
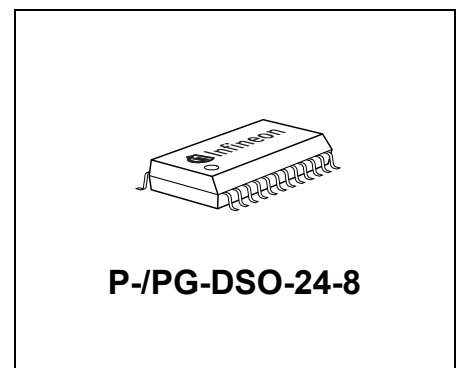
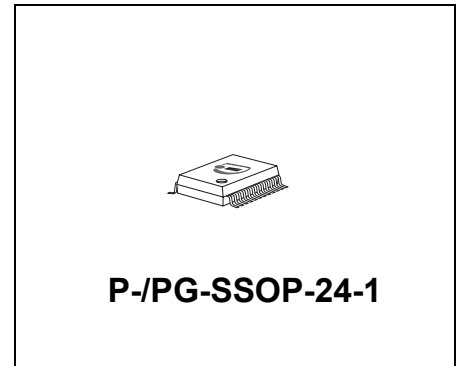

Type	Package
PBL 38640/2 SH	P-/PG-SSOP-24-1
PBL 38640/2 SO	P-/PG-DSO-24-8
PBL 38640/2 QN	P-/PG-LCC-28-3

1.2 Typical Applications

- Basic functionality Central Office Line card
- Digital Loop Carriers (DLC)

1.3 Description

The PBL 38640/2 Subscriber Line Interface Circuit (SLIC) is a 90 V bipolar integrated circuit for use in PBX, Terminal adapters and other telecommunications equipment. The PBL 38640/2 SLIC has been optimized for low total line interface cost and for a high degree of flexibility in different applications.

The PBL 38640/2 SLIC emulates resistive loop feed, programmable between $2 \times 50 \Omega$ and $2 \times 900 \Omega$, with short loop current limiting adjustable to maximum 45 mA. In the current limited region the loop feed is nearly constant current with a slight slope corresponding to $2 \times 30 \text{ k}\Omega$.

A second lower battery voltage may be connected to the device to reduce short loop power dissipation. The SLIC automatically switches between the two battery supply voltages without need for external components or external control.

The SLIC incorporates loop current, ground key and ring-trip detection functions. The PBL 38640/2 is compatible with both loop and ground start signalling.

Two- to four-wire and four- to two-wire voice frequency (VF) signal conversion is accomplished by the SLIC in conjunction with either a conventional CODEC/filter or with a programmable CODEC/filter, for example SiCoFi PEB 2466. The programmable two-wire impedance, complex or real, is set by a simple external network.

Longitudinal voltages are suppressed by a feedback loop in the SLIC and the longitudinal balance specifications meet Bellcore TR909 requirements.

The PBL 38640/2 SLIC package options are 24-pin SSOP, 24-pin PDSO or 28-pin PLCC.

1.4 Block Diagram

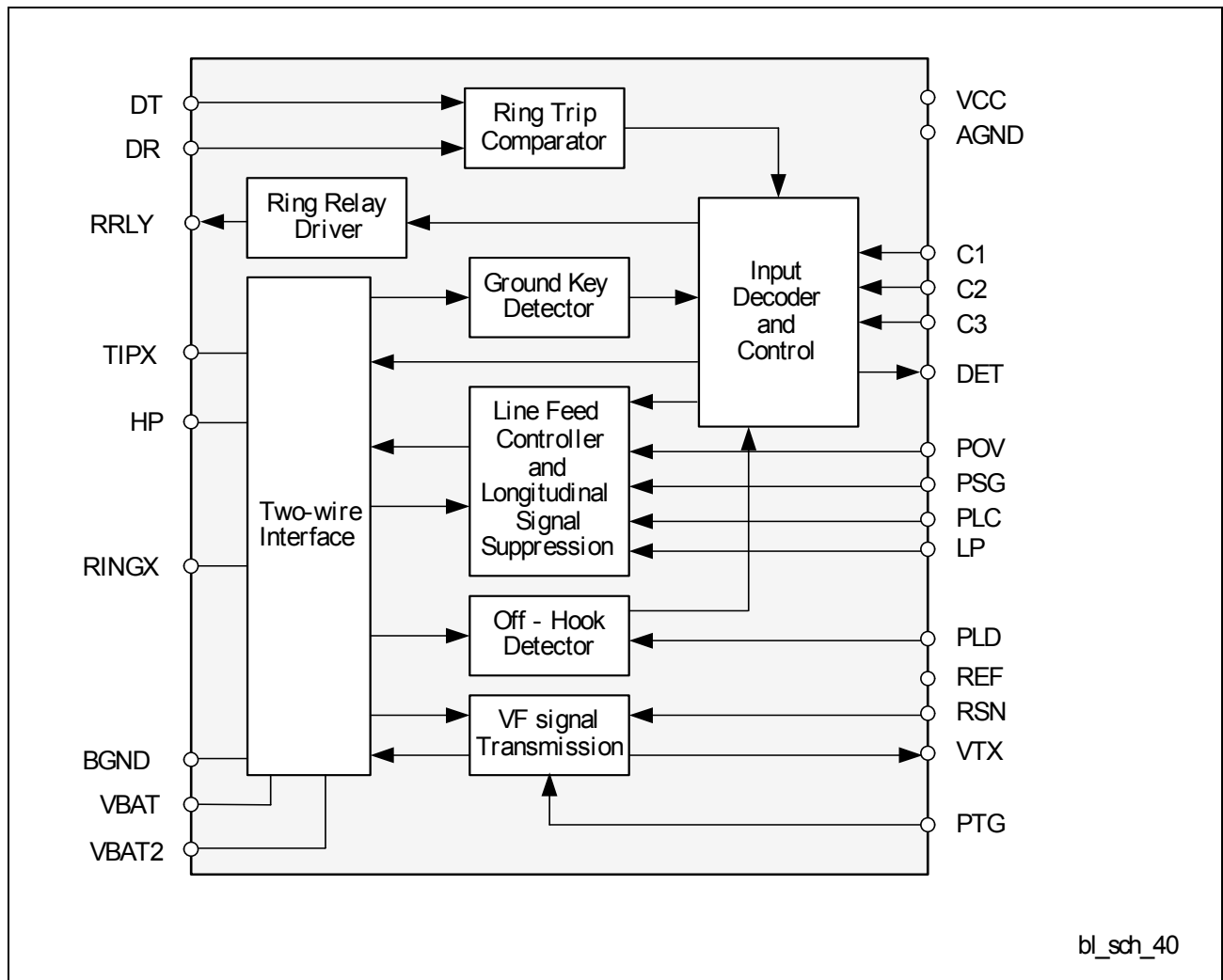

Figure 1 Block Diagram

2 Pin Configuration

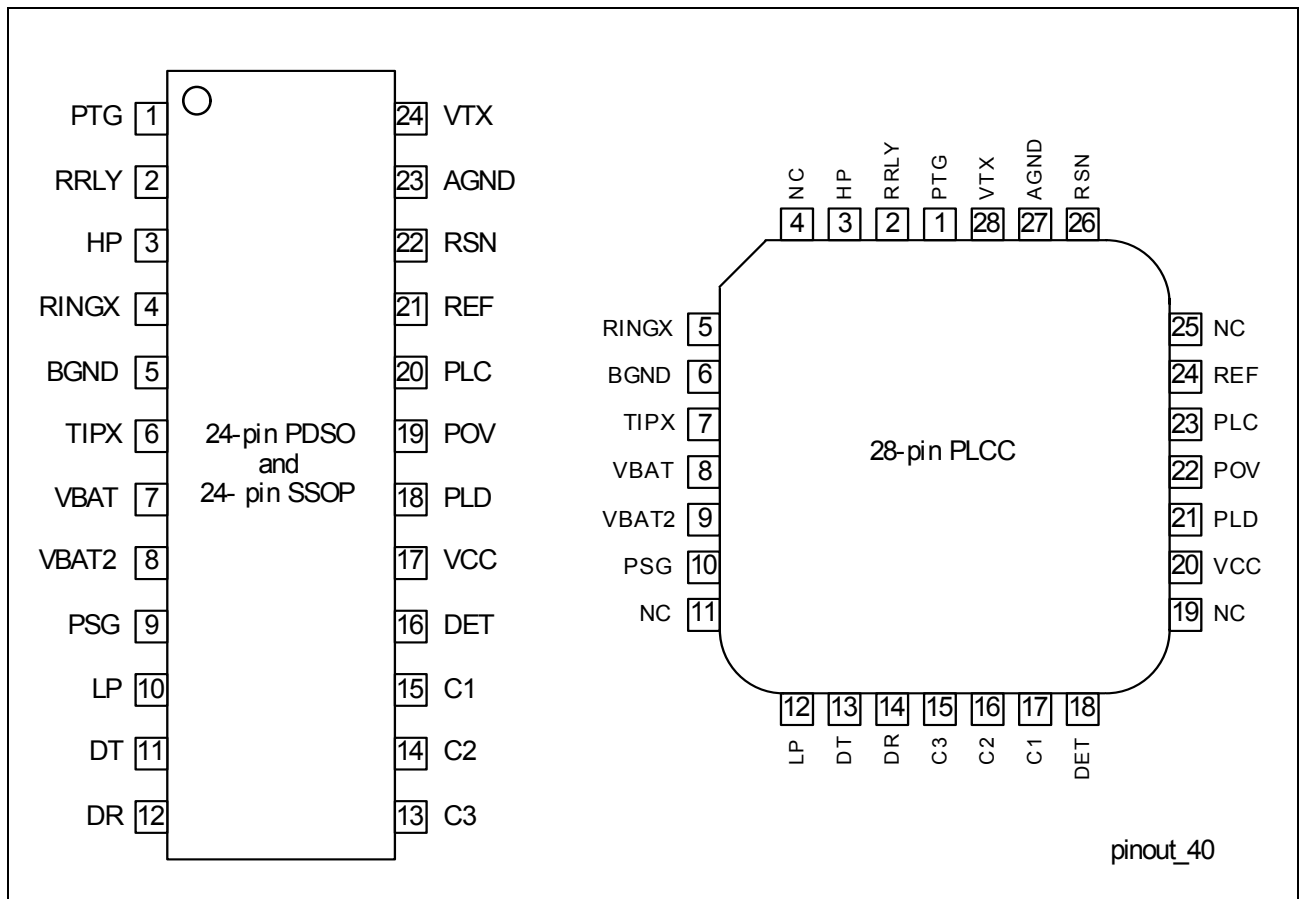

Figure 2 Pin Configuration, 24L-PDSO, 24L-SSOP and 28L-PLCC (top view)

Table 1 Pin Definition and Functions

PDSO SSOP Pin No.	PLCC Pin No.	Name	Pin Type	Function
1	1	PTG	–	Programmable transmit gain. Left open transmit gain = 0.0 dB, connected to AGND transmit gain = -6.02 dB.
2	2	RRLY	O	Ring relay driver output. The relay coil may be connected to maximum +14 V.
3	3	HP	–	Connection for high pass filter capacitor, C_{HP} . Other end of C_{HP} connects to TIPX.

Pin Configuration

Table 1 Pin Definition and Functions (cont'd)

PDSO SSOP Pin No.	PLCC Pin No.	Name	Pin Type	Function
4	5	RINGX	–	The RINGX pin connects to the ring lead of the two-wire interface via over voltage protection components and ring relay (and optional test relay).
5	6	BGND	–	Battery ground, should be tied together with AGND.
6	7	TIPX	–	The TIPX pin connects to the tip lead of the two-wire interface via over voltage protection components and ring relay (and optional test relay).
7	8	V_{BAT}	–	Battery supply voltage. Negative with respect to GND.
8	9	V_{BAT2}	–	An optional second (2) Battery Voltage connects to this pin via an external diode.
9	10	PSG	–	Programmable saturation guard. The resistive part of the DC feed characteristics is programmed by a resistor connected from this pin to V_{BAT} .
10	12	LP	–	Connection for low pass filter capacitor, C_{LP} . Other end of C_{LP} connects to V_{BAT} .
11	13	DT	I	Input to the ring trip comparator. With DR more positive than DT the detector output, DET, is at logic level low, indicating off-hook condition. The external ring trip network connects to this input.
12	14	DR	I	Input to the ring trip comparator. With DR more positive than DT the detector output, DET, is at logic level low, indicating off-hook condition. The external ring trip network connects to this input.
13	15	C3	I	C1, C2, C3 are digital inputs (positive logic, internal pull-up), which control the SLIC operating states. Refer to Table 2 for details.
14	16	C2	I	
15	17	C1	I	

Pin Configuration

Table 1 Pin Definition and Functions (cont'd)

PDSO SSOP Pin No.	PLCC Pin No.	Name	Pin Type	Function
16	18	DET	O	Detector output. Active low when indicating loop or ring-trip detection, active high when indicating ground key detection.
17	20	V_{CC}	–	+5 V power supply.
18	21	PLD	–	Programmable loop detector threshold. The loop detection threshold is programmed by a resistor connected from this pin to AGND.
19	22	POV	–	Programmable overhead voltage. If pin is left open: The overhead voltage is internally set to min 2.7 V in off-hook and min 1.1 V in on-hook. If a resistor is connected between this pin and AGND: The overhead voltage can be set to higher values.
20	23	PLC	–	Programmable line current, the constant current part of the DC feed characteristic is programmed by a resistor connected from this pin to AGND.
21	24	REF	–	A reference, 49.9 k Ω , resistor should be connected from this pin to AGND.
22	26	RSN	–	Receive summing node. 200 times the AC current flowing into this pin equals the metallic (transversal) AC current flowing from RINGX to TIPX. Programming networks for two-wire impedance and receive gain connect to the receive node. A resistor should be connected from this pin to AGND.
23	27	AGND	–	Analog ground, should be tied together with BGND.

Pin Configuration
Table 1 Pin Definition and Functions (cont'd)

PDSO SSOP Pin No.	PLCC Pin No.	Name	Pin Type	Function
24	28	VTX	O	Transmit vf output. The AC voltage difference between TIPX and RINGX, the AC metallic voltage, is reproduced as an unbalanced GND referenced signal at VTX with a gain of one (or one half, see pin PTG). The two-wire impedance programming network connects between VTX and RSN.
-	4, 11,19, 25	NC	-	Not Connected.

Table 2 SLIC Operating States

State	C3	C2	C1	SLIC Operating State	Active Detector (DET Response)
0	0	0	0	Open circuit	No active detector (DET is set high)
1	0	0	1	Ringing	Ring-trip detector (DET active low)
2	0	1	0	Active	Loop detector (DET active low)
3	0	1	1	Active	Line voltage measurement ¹⁾
4	1	0	0	Tip open	Loop detector (DET active low)
5	1	0	1	Active	Ground key detector (DET active high)
6	1	1	0	Active reverse	Loop detector (DET active low)
7	1	1	1	Active reverse	Ground key detector (DET active high)

1) Previous state must be active - loop or ground key detector.

3 Electrical Characteristics

Table 3 Absolute Maximum Ratings

Parameter	Symbol	Values			Unit	Note/Test Condition
		Min.	Typ.	Max.		
Temperature, Humidity						
Storage temperature range	T_{Stg}	-55	–	150	°C	–
Operating temperature range	T_{Amb}	-40	–	110	°C	–
Operating junction temperature range ¹⁾	T_J	-40	–	140	°C	–
Power Supply ($-40\text{ °C} \leq T_{Amb} \leq +85\text{ °C}$)						
V_{CC} with respect to A/BGND	V_{CC}	-0.4	–	6.5	V	–
V_{BAT2} with respect to A/BGND	V_{BAT2}	V_{BAT}	–	0.4	V	–
V_{BAT} with respect to A/BGND, continuous	V_{BAT}	-75	–	0.4	V	–
V_{BAT} with respect to A/BGND, 10 ms	V_{BAT}	-80	–	0.4	V	–
Power Dissipation						
Continuous power dissipation	P_D	–	–	1.5	W	$T_{Amb} \leq +85\text{ °C}$
Ground						
Voltage between AGND and BGND	V_G	-0.3	–	0.3	V	–
Relay Driver						
Ring relay supply voltage	–	–	–	BGND +14	V	–
Ring Trip Comparator						
Input voltage	V_{DT}, V_{DR}	V_{BAT}	–	AGND	V	–
Input current	I_{DT}, I_{DR}	-5	–	5	mA	–
Digital Inputs, Outputs (C1, C2, C3, DET)						
Input voltage	V_{ID}	-0.4	–	V_{CC}	V	–
Output voltage	V_{OD}	-0.4	–	V_{CC}	V	–

Electrical Characteristics
Table 3 Absolute Maximum Ratings (cont'd)

Parameter	Symbol	Values			Unit	Note/Test Condition
		Min.	Typ.	Max.		
TIPX and RINGX Terminals ($-40\text{ }^{\circ}\text{C} \leq T_{\text{Amb}} \leq +85\text{ }^{\circ}\text{C}$, $V_{\text{BAT}} = -50\text{ V}$)						
TIPX or RINGX current	I_{TIPX} , I_{RINGX}	-100	–	100	mA	–
TIPX or RINGX voltage, continuous (referenced to AGND) ²⁾	V_{TA} , V_{RA}	-80	–	2	V	–
TIPX or RINGX ²⁾	V_{TA} , V_{RA}	V_{BAT} - 10	–	5	V	pulse < 10 ms, $t_{\text{Rep}} > 10\text{ s}$
TIPX or RINGX ²⁾	V_{TA} , V_{RA}	V_{BAT} - 25	–	10	V	pulse < 1 μs , $t_{\text{Rep}} > 10\text{ s}$
TIP or RING ²⁾³⁾	V_{TA} , V_{RA}	V_{BAT} - 35	–	15	V	pulse < 250 ns, $t_{\text{Rep}} > 10\text{ s}$

1) The circuit includes thermal protection. Operation above max. junction temperature may degrade device reliability.

2) With the diodes D_{VB} and D_{VB2} included, see [Figure 9](#).

3) R_{F1} and $R_{\text{F2}} > 20\ \Omega$ is also required. Pulse is supplied to RING and TIP outside R_{F1} and R_{F2} .

Attention: Stresses above those values listed here may cause permanent damage to the device. Exposure to absolute maximum rating conditions for extended periods may affect device reliability.

Maximum ratings are absolute ratings; exceeding only one of these values may cause irreversible damage to the integrated circuit.

Table 4 Operating Range

Parameter	Symbol	Values			Unit	Note/Test Condition
		Min.	Typ.	Max.		
Ambient temperature	T_{Amb}	-40	–	85	$^{\circ}\text{C}$	–
V_{CC} with respect to AGND	V_{CC}	4.75	–	5.25	V	–
V_{BAT} with respect to AGND	V_{BAT}	-58	–	-8	V	–
AGND with respect to BGND	V_{G}	-100	–	100	mV	–

3.1 Characteristics

The specification is made with following setup: $-40\text{ }^{\circ}\text{C} \leq T_{\text{Amb}} \leq +85\text{ }^{\circ}\text{C}$, PTG = open (see pin description), $V_{\text{CC}} = +5\text{ V} \pm 5\%$, $V_{\text{BAT}} = -58\text{ V}$ to -40 V , $V_{\text{BAT2}} = -32\text{ V}$, $R_{\text{LC}} = 32.4\text{ k}\Omega$, $I_{\text{L}} = 27\text{ mA}$, $R_{\text{L}} = 600\text{ }\Omega$, $R_{\text{F1}} = R_{\text{F2}} = 0$, $R_{\text{REF}} = 49.9\text{ k}\Omega$, $C_{\text{HP}} = 47\text{ nF}$, $C_{\text{LP}} = 0.15\text{ }\mu\text{F}$, $R_{\text{T}} = 120\text{ k}\Omega$, $R_{\text{SG}} = 0\text{ k}\Omega$, $R_{\text{RX}} = 60\text{ k}\Omega$, $R_{\text{R}} = 52.3\text{ k}\Omega$, $R_{\text{OV}} = \text{infinite}$.

Current definition: current is positive if flowing into a pin unless stated otherwise.

Table 5 Characteristics

Parameter	Symbol	Values			Unit	Note/Test Condition
		Min.	Typ.	Max.		
Two-Wire Port						
Overhead level ¹⁾ , $18\text{ mA} \leq I_{\text{LDC}}$ Active, 1% THD $R_{\text{OV}} = \text{infinite}$ see Figure 3	V_{TRO}	2.7	–	–	V_{Peak}	–
		1.1	–	–	V_{Peak}	On-Hook, $I_{\text{LDC}} \leq 5\text{ mA}$
Input impedance ²⁾	Z_{TRX}	–	$Z_{\text{T}}/200$	–	Ω	–
Longitudinal impedance	$Z_{\text{LOT}},$ Z_{LOR}	–	20	35	Ω/wire	$0 < f < 100\text{ Hz}$
Longitudinal current limit	$I_{\text{LOT}},$ I_{LOR}	28	–	–	$\text{mA}_{\text{rms}}/\text{wire}$	Active

Electrical Characteristics

Table 5 Characteristics (cont'd)

Parameter	Symbol	Values			Unit	Note/Test Condition
		Min.	Typ.	Max.		
Longitudinal to metallic balance (IEEE standard 455-1985), $Z_{TRX} = 736 \Omega$ Normal polarity	B_{LM}	63	66	–	dB	$0.2 \text{ kHz} \leq f \leq 1.0 \text{ kHz}$ $T_{AMB} 0-70 \text{ }^\circ\text{C}$
		60	66	–	dB	$1.0 \text{ kHz} < f < 3.4 \text{ kHz}$ $T_{AMB} 0-70 \text{ }^\circ\text{C}$
		60	66			$0.2 \text{ kHz} \leq f \leq 1.0 \text{ kHz}$ $T_{AMB} -40-85 \text{ }^\circ\text{C}$
		55	66	–	dB	$1.0 \text{ kHz} < f < 3.4 \text{ kHz}$ $T_{AMB} -40-85 \text{ }^\circ\text{C}$
Reverse polarity	B_{LM}	59	66	–	dB	$0.2 \text{ kHz} \leq f \leq 1.0 \text{ kHz}$ $T_{AMB} 0-70 \text{ }^\circ\text{C}$
		55	66	–	dB	$1.0 \text{ kHz} < f < 3.4 \text{ kHz}$ $T_{AMB} 0-70 \text{ }^\circ\text{C}$
		55	66			$0.2 \text{ kHz} \leq f \leq 1.0 \text{ kHz}$ $T_{AMB} -40-85 \text{ }^\circ\text{C}$
		55	66	–	dB	$1.0 \text{ kHz} < f < 3.4 \text{ kHz}$ $T_{AMB} -40-85 \text{ }^\circ\text{C}$

Electrical Characteristics

Table 5 Characteristics (cont'd)

Parameter	Symbol	Values			Unit	Note/Test Condition
		Min.	Typ.	Max.		
Longitudinal to metallic balance $B_{LME} = 20 \times \log E_{LO}/V_{TR} $, see Figure 4 Normal polarity	B_{LME}	63	66	–	dB	$0.2 \text{ kHz} \leq f \leq 1.0 \text{ kHz}$ $T_{AMB} \text{ 0-70 } ^\circ\text{C}$
		60	66	–	dB	$1.0 \text{ kHz} < f < 3.4 \text{ kHz}$ $T_{AMB} \text{ 0-70 } ^\circ\text{C}$
Reverse polarity	B_{LME}	60	66			$0.2 \text{ kHz} \leq f \leq 1.0 \text{ kHz}$ $T_{AMB} \text{ -40-85 } ^\circ\text{C}$
		55	66	–	dB	$1.0 \text{ kHz} < f < 3.4 \text{ kHz}$ $T_{AMB} \text{ -40-85 } ^\circ\text{C}$
		59	66	–	dB	$0.2 \text{ kHz} \leq f \leq 1.0 \text{ kHz}$ $T_{AMB} \text{ 0-70 } ^\circ\text{C}$
		55	66	–	dB	$1.0 \text{ kHz} < f < 3.4 \text{ kHz}$ $T_{AMB} \text{ 0-70 } ^\circ\text{C}$
		55	66			$0.2 \text{ kHz} \leq f \leq 1.0 \text{ kHz}$ $T_{AMB} \text{ -40-85 } ^\circ\text{C}$
		55	66	–	dB	$1.0 \text{ kHz} < f < 3.4 \text{ kHz}$ $T_{AMB} \text{ -40-85 } ^\circ\text{C}$

Electrical Characteristics

Table 5 Characteristics (cont'd)

Parameter	Symbol	Values			Unit	Note/Test Condition
		Min.	Typ.	Max.		
Longitudinal to four-wire balance $B_{LFE} = 20 \times \log E_{LO}/V_{TX} $, see Figure 4 Normal polarity	B_{LFE}	63	66	–	dB	0.2 kHz $\leq f \leq$ 1.0 kHz T_{AMB} 0-70 °C
		60	66	–	dB	1.0 kHz $< f <$ 3.4 kHz T_{AMB} 0-70 °C
		60	66			0.2 kHz $\leq f \leq$ 1.0 kHz T_{AMB} -40-85 °C
		55	66	–	dB	1.0 kHz $< f <$ 3.4 kHz T_{AMB} -40-85 °C
		59	66	–	dB	0.2 kHz $\leq f \leq$ 1.0 kHz T_{AMB} 0-70 °C
		55	66	–	dB	1.0 kHz $< f <$ 3.4 kHz T_{AMB} 0-70 °C
		55	66			0.2 kHz $\leq f \leq$ 1.0 kHz T_{AMB} -40-85 °C
		55	66	–	dB	1.0 kHz $< f <$ 3.4 kHz T_{AMB} -40-85 °C
Reverse polarity						
Metallic to longitudinal balance $B_{MLE} = 20 \times \log V_{TR}/V_{LO} $, $E_{RX} = 0$ V, see Figure 5	B_{MLE}	40	50	–	dB	0.2 kHz $< f <$ 3.4 kHz
Four-wire to longitudinal balance $B_{FLE} = 20 \times \log E_{RX}/V_{LO} $, see Figure 5	B_{FLE}	40	50	–	dB	0.2 kHz $< f <$ 3.4 kHz

Electrical Characteristics
Table 5 Characteristics (cont'd)

Parameter	Symbol	Values			Unit	Note/Test Condition
		Min.	Typ.	Max.		
Two-wire return loss ³⁾ $r = 20 \times \log \frac{ Z_{TRX} + Z_L }{ Z_{TRX} - Z_L }$	r	30	35	–	dB	0.2 kHz < f < 1.0 kHz
		20	22	–	dB	1.0 kHz < f < 3.4 kHz
TIPX idle voltage	V_{TI}	–	-1.3	–	V	Active, $I_L < 5$ mA
RINGX idle voltage	V_{RI}	–	V_{BAT+} 3.0	–	V	Active, $I_L < 5$ mA
		–	V_{BAT+} 3.0	–	V	Tip open, $I_L < 5$ mA
Open loop voltage	V_{TR}	–	V_{BAT+} 4.3	–	V	Active, $I_L < 5$ mA

Four-Wire Transmit Port (VTX)

Overhead level ⁴⁾ , Load imp. > 20 k Ω 1% THD see Figure 6	V_{TXO}	2.7	–	–	V_{Peak}	$I_L > 18$ mA
		1.1	–	–	V_{Peak}	On-Hook, $I_L \leq 5$ mA
Output offset voltage	ΔV_{TX}	-100	–	100	mV	–
Output impedance	Z_{TX}	–	15	50	Ω	0.2 kHz < f < 3.4 kHz

Four-Wire Receive Port (receive summing node = RSN)

RSN DC voltage	V_{RSNdc}	1.15	1.25	1.35	V	$I_{RSN} = -55$ μ A
RSN impedance		–	8	20	Ω	0.2 kHz < f < 3.4 kHz
RSN current (I_{RSN}) to metallic loop current (I_L) gain	α_{RSN}	–	200	–	ratio	0.3 kHz < f < 3.4 kHz

Frequency Response

Two-wire to four-wire, relative to 0 dBm, 1.0 kHz, $E_{RX} = 0$ V, see Figure 7	g_{2-4}	-0.20	–	0.10	dB	0.3 kHz < f < 3.4 kHz
		-1.0	–	0.1	dB	$f = 8$ kHz, 12 kHz, 16 kHz

Electrical Characteristics

Table 5 Characteristics (cont'd)

Parameter	Symbol	Values			Unit	Note/Test Condition
		Min.	Typ.	Max.		
Four-wire to two-wire, relative to 0 dBm, 1.0 kHz, $E_L = 0$ V, see Figure 7	g ₄₋₂	-0.2	–	0.1	dB	0.3 kHz < f < 3.4 kHz
		-1.0	–	0	dB	f = 8 kHz, 12 kHz
		-2.0	–	0	dB	f = 16 kHz
Four-wire to four-wire, relative to 0 dBm, 1.0 kHz, $E_L = 0$ V, see Figure 7	g ₄₋₄	-0.2	–	0.1	dB	0.3 kHz < f < 3.4 kHz
Insertion Loss						
Two-wire to four-wire ⁵⁾ , $G_{2-4} = 20 \times \log V_{TX}/V_{TR} $ 0 dBm, 1.0 kHz $E_{RX} = 0$ V	G ₂₋₄	-0.2	–	0.2	dB	PTG = Open see Figure 7
		-6.22	-6.02	-5.82	dB	PTG = AGND
Four-wire to two-wire ⁶⁾ , $G_{4-2} = 20 \times \log V_{TR}/V_{RX} $, $E_L = 0$ V, see Figure 7	G ₄₋₂	-0.2	–	0.2	dB	0 dBm, 1.0 kHz
Gain Tracking						
Two-wire to four-wire ⁷⁾ , Ref. -10 dBm, 1.0 kHz, see Figure 7		-0.1	–	0.1	dB	-40 dBm to +3 dBm
		-0.2	–	0.2	dB	-55 dBm to -40 dBm
Four-wire to two-wire, Ref. -10 dBm, 1.0 kHz, see Figure 7		-0.1	–	0.1	dB	-40 dBm to +3 dBm
		-0.2	–	0.2	dB	-55 dBm to -40 dBm
Noise						
Idle channel noise at two-wire port ⁸⁾ (TIPX-RINGX) or four-wire (VTX) output		–	–	12	dBrnC	C-message weighting
		–	–	-78	dBmp	Psophometrical weighting

Electrical Characteristics
Table 5 Characteristics (cont'd)

Parameter	Symbol	Values			Unit	Note/Test Condition
		Min.	Typ.	Max.		
Harmonic Distortion						
Two-wire to four-wire, see Figure 7		–	-67	-50	dB	0 dBm 0.3 kHz < f <
Four-wire to two-wire		–	-67	-50	dB	3.4 kHz
Battery Feed Characteristics						
Loop current in the current limited region, reference A, B & C see Figure 13	I_L	$0.92 \times I_L$	I_L	$1.08 \times I_L$	mA	$18 \text{ mA} \leq I_L \leq 45 \text{ mA}$
Tip open state TIPX current see Figure 8	I_{Leak}	–	–	-100	μA	S = closed; R = 7 k Ω ⁹⁾
Tip open state RINGX current see Figure 8	I_{LRTo}	–	I_L	–	mA	$R_{LRTo} = 0 \Omega$, $V_{Bat} = -48 \text{ V}$
		–	17	–	mA	$R_{LRTo} = 2.5 \text{ k}\Omega$, $V_{Bat} = -48 \text{ V}$
Tip open state RINGX voltage see Figure 8	V_{RTo}	–	$V_{Bat} + 6$	–	V	$I_{LRTo} < 23 \text{ mA}$
Tip voltage (ground start) see Figure 8	–	-4	-2.2	–	V	Active state, Tip lead open (S open), Ring lead to ground through 150 Ω
Tip voltage (ground start) see Figure 8	–	-6	-2.4	–	V	Active state, Tip lead to -48 V through 7 k Ω (S closed), Ring lead to ground through 150 Ω
Open circuit loop current	I_{LOC}	-100	0	100	μA	$R_L = 0 \Omega$

Electrical Characteristics
Table 5 Characteristics (cont'd)

Parameter	Symbol	Values			Unit	Note/Test Condition
		Min.	Typ.	Max.		
Loop Detector						
Programmable threshold,	I_{LTh}	$0.85 \times I_{LTh}$	I_{LTh}	$1.15 \times I_{LTh}$	mA	$I_{LTh} = 500/R_{LD}$ R_{LD} in $k\Omega$, $7 \text{ mA} \leq I_{LTh}$
Tip open state	–	$0.85 \times I_{LTh}$	I_{LTh}	$1.15 \times I_{LTh}$	mA	$I_{LTh} = 500/R_{LD}$
Ground Key Detector						
Ground key detector threshold	–	10	16	22	mA	(I_{LTIPX} and I_{LRINGX} current difference to trigger ground key detector)
Line Voltage Measurement						
Pulse width ¹⁰⁾	t_{LVM}	–	5.5	–	$\mu\text{s/V}$	
Ring Trip Comparator						
Offset voltage	ΔV_{DTDR}	-20	0	20	mV	Source resistance, $R_S = 0 \Omega$
Input bias current	I_B	-200	-20	200	nA	$I_B = (I_{DT} + I_{DR})/2$
Input common mode range	V_{DT}, V_{DR}	$V_{BAT} + 1$	–	-1	V	
Ring Relay Driver						
Saturation voltage	V_{OL}	–	0.2	0.5	V	$I_{OL} = 50 \text{ mA}$
Off state leakage current	I_{LK}	–	–	10	μA	$V_{OH} = 12 \text{ V}$
Digital Inputs (C1, C2, C3)						
Input low voltage	V_{IL}	0	–	0.5	V	–
Input high voltage	V_{IH}	2.5	–	V_{CC}	V	–
Input low current	I_{IL}	–	–	-50	μA	$V_{IL} = 0.5 \text{ V}$
Input high current	I_{IH}	–	–	50	μA	$V_{IH} = 2.5 \text{ V}$

Electrical Characteristics
Table 5 Characteristics (cont'd)

Parameter	Symbol	Values			Unit	Note/Test Condition
		Min.	Typ.	Max.		
Detector Output (DET)						
Output low voltage	V_{OL}	–	–	0.7	V	$I_{OL} = 0.5 \text{ mA}$
Internal pull-up resistor to V_{CC}		–	15	–	k Ω	–
Power Dissipation ($V_{BAT} = -48 \text{ V}$, $V_{BAT2} = -32 \text{ V}$)						
Power Dissipation	P_1	–	10	15	mW	Open circuit (C1, C2, C3 = 0)
Power Dissipation	P_2	–	65	85	mW	Active (On-hook) Long current = 0 mA
Power Dissipation	P_3	–	730	–	mW	Active (Off-hook) $R_L = 300 \Omega$
Power Dissipation	P_4	–	360	–	mW	Active (Off-hook) $R_L = 800 \Omega$
Power Supply Currents ($V_{BAT} = -48 \text{ V}$)						
V_{CC} current	I_{CC}	–	1.2	2.0	mA	Open circuit (C1, C2, C3 = 0)
V_{BAT} current	I_{BAT}	-0.1	-0.05	–	mA	Open circuit (C1, C2, C3 = 0)
V_{CC} current	I_{CC}	–	2.8	4.0	mA	Active, On-hook, Long current = 0 mA
V_{BAT} current	I_{BAT}	-1.5	-1.0	–	mA	Active, On-hook, Long current = 0 mA
Power Supply Rejection Ratios						
V_{CC} to 2- or 4-wire port		30	42	–	dB	Active, $f = 1 \text{ kHz}$, $V_n = 100 \text{ mV}$
V_{BAT2} to 2- or 4-wire port		40	60	–	dB	Active, $f = 1 \text{ kHz}$, $V_n = 100 \text{ mV}$
V_{BAT} to 2- or 4-wire port		36	45	–	dB	Active, $f = 1 \text{ kHz}$, $V_n = 100 \text{ mV}$