



Chipsmall Limited consists of a professional team with an average of over 10 year of expertise in the distribution of electronic components. Based in Hongkong, we have already established firm and mutual-benefit business relationships with customers from,Europe,America and south Asia,supplying obsolete and hard-to-find components to meet their specific needs.

With the principle of “Quality Parts,Customers Priority,Honest Operation,and Considerate Service”,our business mainly focus on the distribution of electronic components. Line cards we deal with include Microchip,ALPS,ROHM,Xilinx,Pulse,ON,Everlight and Freescale. Main products comprise IC,Modules,Potentiometer,IC Socket,Relay,Connector.Our parts cover such applications as commercial,industrial, and automotives areas.

We are looking forward to setting up business relationship with you and hope to provide you with the best service and solution. Let us make a better world for our industry!



Contact us

Tel: +86-755-8981 8866 Fax: +86-755-8427 6832

Email & Skype: info@chipsmall.com Web: www.chipsmall.com

Address: A1208, Overseas Decoration Building, #122 Zhenhua RD., Futian, Shenzhen, China



TO ; _____

S P E C I F I C A T I O N S

Product Name PHOTOCOUPLER

Model No. PC123

Business dealing name

| | |
|--|--------------|
| | PC123Y13FZ9F |
| | PC123Y23FZ9F |
| | PC123Y53FZ9F |
| | PC123Y83FZ9F |
| | PC123Y93FZ9F |

These specifications contain 14 pages including the cover and appendix.
 This specification sheets and attached sheets shall be both side copy.
 After confirmation of the contents, please be sure to send back copy of the
 Specifications with approving signature on each.
 If you have any objections, please contact us before issuing purchasing order.

Accepted by:

By : _____
 Name : _____
 Title : _____
 Date : _____
 By : _____
 Name : _____
 Title : _____
 Date : _____

Sharp Corporation
 By : 
 Name : T. Ichinose,
 Title : Division Manager,
 Development Division. V
 System Device Business Unit
 Electronic Components and Devices BU
 Date : Nov. 24, 2016

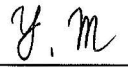
| | |
|---|--|
| Reviewed by : | Prepared by : |
| By :  | By :  |
| Name : T.Okuda | Name : Y.Matsuo |
| Title : Senior Manager | Title : Supervisor |
| Date : <u>24 Nov, 2016</u> | Date : <u>Nov. 24, 2016</u> |

1. These specification sheets include materials protected under copyright of Sharp Corporation ("Sharp").
Please handle with great cares and do not reproduce or cause anyone to reproduce them without Sharp's consent.
2. When using this Sharp product, please observe the absolute maximum ratings, other conditions and instructions for use described in the specification sheets, as well as the precautions mentioned below.
Sharp assumes no responsibility for any damages resulting from use of the product which does not comply with absolute maximum ratings, other conditions and instructions for use included in the specification sheets, and the precautions mentioned below.

(Precautions)

- (1) In making catalogue or instruction manual based on the specification sheets, please verify the validity of the catalogue or instruction manuals after assembling Sharp products in customer's products at the responsibility of customer.
- (2) This Sharp product is designed for use in the following application areas ;
 - Computers • OA equipment • Telecommunication equipment (Terminal) • Measuring equipment
 - Tooling machines • Audio visual equipment • Home appliances
 If the use of the Sharp product in the above application areas is for equipment listed in paragraphs (3) or (4), please be sure to observe the precautions given in those respective paragraphs.
- (3) Appropriate measures, such as fail-safe design and redundant design considering the safety design of the overall system and equipment, should be taken to ensure reliability and safety when Sharp product is used for equipment in responsibility of customer which demands high reliability and safety in function and precision, such as ;
 - Transportation control and safety equipment (aircraft, train, automobile etc.)
 - Traffic signals • Gas leakage sensor breakers • Rescue and security equipment • Other safety equipment
- (4) Sharp product is designed for consumer goods and controlled as consumer goods in production and quality.
Please do not use this product for equipment which require extremely high reliability and safety in function and precision, such as ;
 - Space equipment • Telecommunication equipment (for trunk lines)
 - Nuclear power control equipment • Medical equipment
- (5) Please contact and consult with a Sharp sales representative if there are any question regarding interpretation of the above four paragraphs.

3. Disclaimer

The warranty period for Sharp product is one (1) year after shipment.

During the period, if there are any products problem, Sharp will repair (if applicable), replace or refund.

Except the above, both parties will discuss to cope with the problems.

The failed Sharp product after the above one (1) year period will be coped with by Sharp, provided that both parties shall discuss and determine on sharing responsibility based on the analysis results thereof subject to the above scope of warranty.

The warranty described herein is only for Sharp product itself which are purchased by or delivered to customer.

Damages arising from Sharp product malfunction or failure shall be excepted.

Sharp will not be responsible for the Sharp product due to the malfunction or failures thereof which are caused by:

- (1) storage keep trouble during the inventory in the marketing channel.
- (2) intentional act, negligence or wrong/poor handling.
- (3) equipment which Sharp products are connected to or mounted in.
- (4) disassembling, reforming or changing Sharp products.
- (5) installation problem.
- (6) act of God or other disaster (natural disaster, fire, flood, etc.)
- (7) external factors (abnormal voltage, abnormal electromagnetic wave, fire, etc.)
- (8) special environment (factory, coastal areas, hot spring area, etc.)
- (9) phenomenon which cannot be foreseen based on the practical technologies at the time of shipment.
- (10) the factors not included in the product specification sheet.

4. Please contact and consult with a Sharp sales representative for any questions about Sharp product.

5. Warranty term and warranty limits**【Warranty term】**

The warranty term for the shipped product shall be for 1 year after shipping to the designated place by the ordered customer.

【Warranty limits】

SHARP supplies the replacement when this SHARP product shall be failed by SHARP's responsibility during above warranty term. However, this warranty is excluded in case of the following.

- (1) In case of improper handling and using by the customer.
- (2) In case of that the cause of the failure is caused by the reason other than this SHARP product.
- (3) In case of modification and repairing by person other than SHARP responsibility is not for SHARP.
- (4) In case of a calamity, a disaster and such as the case when that responsibility is not for SHARP.

This warranty herein means the warranty for this SHARP product itself, SHARP takes no responsibility for any damage caused by the failure of this SHARP product.

1. Application

This specification applies to the outline and characteristics of photocoupler Model No. PC123.(Lead-Free and Halogen free Type).

2. Outline Refer to the attached sheet, page 6.

3. Ratings and characteristics Refer to the attached sheet, page 7, 8.

4. Reliability Refer to the attached sheet, page 9.

5. Outgoing inspection Refer to the attached sheet, page 10.

6. Supplement

6.1 Isolation voltage shall be measured in the following method.

- (1) Short between anode and cathode on the primary side and between collector and emitter on the secondary side.
- (2) The dielectric withstanding tester with zero-cross circuit shall be used.
- (3) The wave form of applied voltage shall be a sine wave.
(It is recommended that the isolation voltage be measured in insulation oil.)

6.2 Packing specifications Refer to the attached sheet, page 11, 12.

6.3 Collector current (Ic) Delivery rank table ("O" mark indicates business dealing name of ordered product)

| Rank at delivery | * Business dealing name | Rank mark | Ic (mA) | Test condition I _F =5mA V _{CE} =5V T _a =25°C |
|------------------|-------------------------|-----------|--------------|--|
| | PC123Y13FZ9F | L | 2.5 to 7.5 | |
| | PC123Y23FZ9F | M | 5.0 to 12.5 | |
| | PC123Y53FZ9F | N | 10.0 to 20.0 | |
| | PC123Y83FZ9F | E | 5.0 to 10.0 | |
| | PC123Y93FZ9F | C | 8.0 to 15.0 | |

6.4 This product is approved by VDE according to DIN EN60747-5-5.

Isolation specification according to EN60747-5-5

| Parameter | Symbol | Condition | Rating | Unit | Remark |
|---|-------------------------|--------------------|--------|------|---------------------------------------|
| Maximum operating isolation voltage | V_{IORM} (PEAK) | - | 1140 | V | Refer to the Diagram 1, 2 (Page 5/12) |
| Partial discharge test voltage (Between input and output) | - | - | - | - | |
| Diagram 1 | V_{pr} | $t_p=60s, q_c<5pC$ | 1275 | V | |
| Diagram 2 | (PEAK) | $t_p=1s, q_c<5pC$ | 1594 | V | |
| Maximum over-voltage | $V_{INITIAL}$ (PEAK) | $t_{INI}=10s$ | 8000 | V | |
| Safety maximum ratings | - | - | - | - | - |
| 1) Case temperature | T_{si} | $I_F=0, P_C=0$ | 175 | °C | |
| 2) Input current | I_{si} | $P_C=0$ | 400 | mA | |
| 3) Electric power (Output or Total power dissipation) | P_{si} | - | 700 | mW | |

Precautions in performing isolation test

- (1) Partial discharge test methods shall be the ones according to the specifications of EN60747-5-5
- (2) Please don't carry out isolation test (V_{iso}) over $V_{INITIAL}$.
This product deteriorates isolation characteristics by partial discharge due to applying high voltage (ex. $V_{INITIAL}$).
And there is possibility that partial discharge occurs in operating isolation voltage. (V_{IORM}).

6.5 This product is approved by UL, CSA, BSI, SEMKO, DEMKO, NEMKO, FIMKO, and CQC.

6.6 This product is not designed against irradiation.
This product is assembled with electrical input and output.
This product incorporates non-coherent light emitting diode.

6.7 ODS materials
This product shall not contain the following materials.
Also, the following materials shall not be used in the production process for this product.
Materials for ODS : CFCs, Halon, Carbon tetrachloride, 1.1.1-Trichloroethane (Methyl chloroform)

6.8 Specified brominated flame retardants
Specified brominated flame retardants (PBB and PBDE) are not used in this device at all.

6.9 Compliance with each regulation

- (1) The RoHS directive(2011/65/EU)

This product complies with the RoHS directive(2011/65/EU) .

Object substances: mercury, lead, cadmium, hexavalent chromium, polybrominated biphenyls (PBB) and polybrominated diphenyl ethers (PBDE)

- (2) Content of six substances specified in Management Methods for Control of Pollution Caused by Electronic Information Products Regulation (Chinese : 电子信息产品污染控制管理办法).

Marking Styles for the Names and Contents of the Hazardous Substances

| Category | Hazardous Substances | | | | | |
|--------------|----------------------|--------------|--------------|---|--------------------------------|---------------------------------------|
| | Lead (Pb) | Mercury (Hg) | Cadmium (Cd) | Hexavalent chromium (Cr ⁶⁺) | Polybrominated biphenyls (PBB) | Polybrominated diphenyl ethers (PBDE) |
| Photocoupler | ○ | ○ | ○ | ○ | ○ | ○ |

This table is prepared in accordance with the provisions of SJ/T 11364.

○ : Indicates that said hazardous substance contained in all of the homogeneous materials for this part is below the limit requirement of GB/T 26572

- (3) This product complies with “Halogen free”.

“Halogen free” about this product is defined as follows.

The concentration ratio of Chlorinate and Bromine in raw material and indirect material , finished product can not exceed 900 ppm, the total concentration of the 2 substance should not exceed 1500 ppm.

7. Notes

Precautions for photocouplers : Attachment-1

REFERENCE

• Method of Diagram 1: Breakdown test (Apply to type test and sampling test)

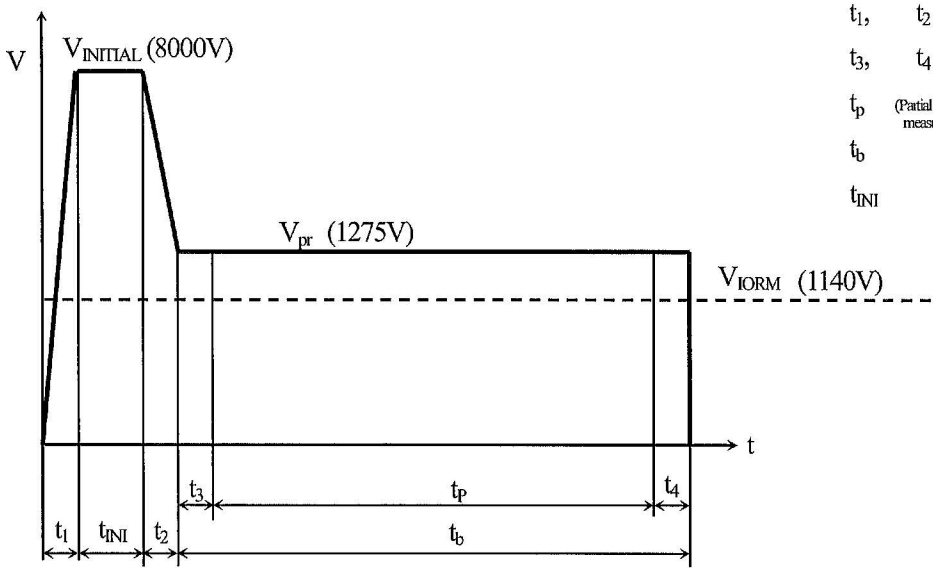

| | |
|--|-------------|
| t_1, t_2 | = 1 to 10 s |
| t_3, t_4 | = 1 s |
| t_p (Partial discharge measuring time) | = 60 s |
| t_b | = 62 s |
| t_{INI} | = 10 s |

• Method of Diagram 2: Non breakdown test (Apply to all device test)

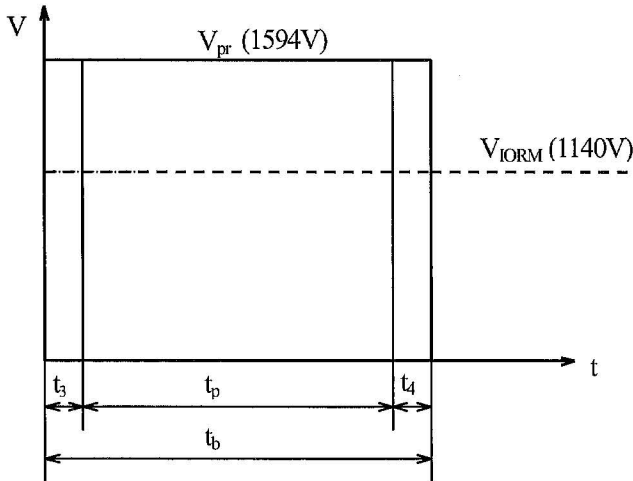

| | |
|--|---------|
| t_3, t_4 | = 0.1 s |
| t_p (Partial discharge measuring time) | = 1 s |
| t_b | = 1.2 s |

2. Outline

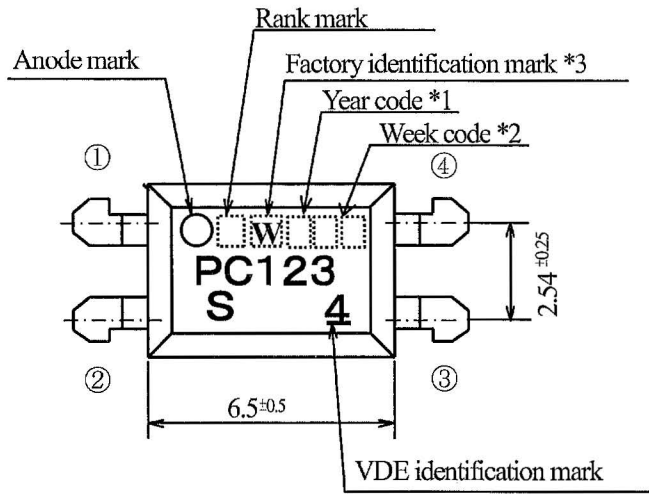

Pin-Number and internal connection diagram

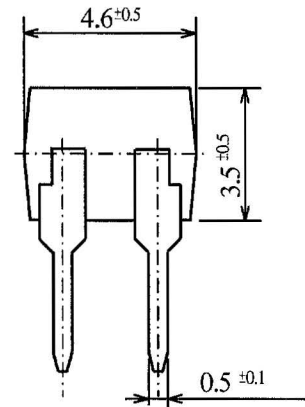
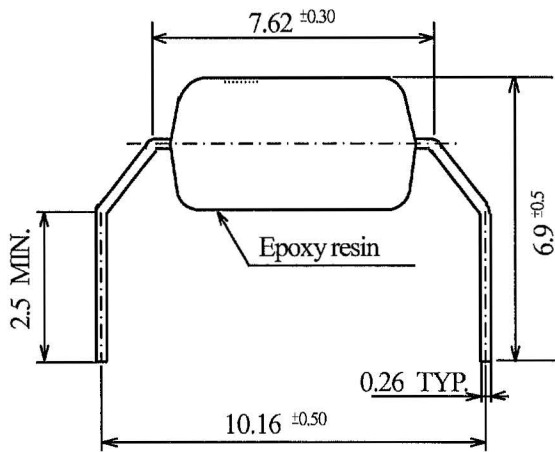
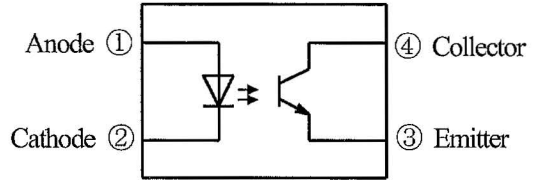

- *1) Year date code
- *2) 2-digit work week
- *3) Factory identification marks applies to the below
W : Lite-ON OPTO Technology (Changzhou) Co., Ltd. (CHINA)

Pin material : Cu Alloy
Pin finish : Pure Tin plating

Product mass : Approx. 0.23 g

Marking is laser marking

| | |
|---------------|--|
| UNIT : 1/1 mm | |
| Name | PC123 Outline Dimensions (Business dealing name : PC123Y*3FZ9F) |

3. Ratings and characteristics

3.1 Absolute maximum ratings

Ta=25°C

| Parameter | | Symbol | Rating | Unit |
|--------------------------|--------------------------------|------------------------|-------------|------|
| Input | Forward current *1 | I _F | 50 | mA |
| | Peak forward current | I _{FM} | 1 | A |
| | Reverse voltage | V _R | 6 | V |
| | Power dissipation | P | 70 | mW |
| Output | Collector-emitter voltage | V _{CEO} | 70 | V |
| | Emitter-collector voltage | V _{ECO} | 6 | V |
| | Collector current | I _c | 50 | mA |
| | Collector power dissipation *1 | P _c | 150 | mW |
| Total power dissipation | | P _{tot} | 200 | mW |
| Operating temperature | | T _{opr} | -30 to +100 | °C |
| Storage temperature | | T _{stg} | -55 to +125 | °C |
| Isolation voltage *2 | | V _{iso (rms)} | 5 | kV |
| Soldering temperature *3 | | T _{sol} | 270 | °C |

*1 The derating factors of absolute maximum ratings due to ambient temperature are shown in Fig. 1 to 2.

*2 AC For 1 min, 40 to 60%RH

Isolation voltage shall be measured using the following method.

(1) Short between anode and cathode on the primary side and between collector and emitter on the secondary side.

(2) The isolation voltage tester with zero-cross circuit shall be used.

(3) The waveform of applied voltage shall be a sine wave.

*3 For 10s

3.2 Electro-optical characteristics

Ta=25°C

| Parameter | | Symbol | Condition | MIN. | TYP. | MAX. | Unit |
|--------------------------|--------------------------------------|----------------------|--|------------------|------|------|------|
| Input | Forward voltage | V _F | I _F =20mA | - | 1.2 | 1.4 | V |
| | Reverse current | I _R | V _R =4V | - | - | 10 | μA |
| | Terminal capacitance | C _t | V=0, f=1kHz | - | 30 | 250 | pF |
| Output | Dark current | I _{CEO} | V _{CE} =50V, I _F =0 | - | - | 100 | nA |
| | Collector-emitter breakdown voltage | BV _{CEO} | I _c =0.1mA, I _F =0 | 70 | - | - | V |
| | Emitter-collector breakdown voltage | BV _{ECO} | I _c =10 μA, I _F =0 | 6 | - | - | V |
| Transfer characteristics | Collector current | I _c | I _F =5mA, V _{CE} =5V | 2.5 | - | 20 | mA |
| | *5 Current Transfer Ratio | CTR | | 50 | - | 400 | % |
| | Collector-emitter saturation voltage | V _{CE(sat)} | I _F =20mA, I _c =1mA | - | 0.1 | 0.2 | V |
| | Isolation resistance | R _{ISO} | DC500V 40 to 60%RH | 10 ¹² | - | - | Ω |
| | Floating capacitance | C _f | V=0, f=1MHz | - | 0.6 | 1.0 | pF |
| | Cut-off frequency | f _c | V _{CE} =5V, I _c =2mA R _L =100Ω, -3dB | - | 80 | - | kHz |
| | Response time (Rise) | t _r | V _{CE} =2V, I _c =2mA R _L =100Ω | - | 4 | 18 | μs |
| Response time (Fall) | t _f | - | | 3 | 18 | μs | |

*4 CTR (%) = (I_c / I_F) × 100

(Fig. 1) Forward current vs. ambient temperature

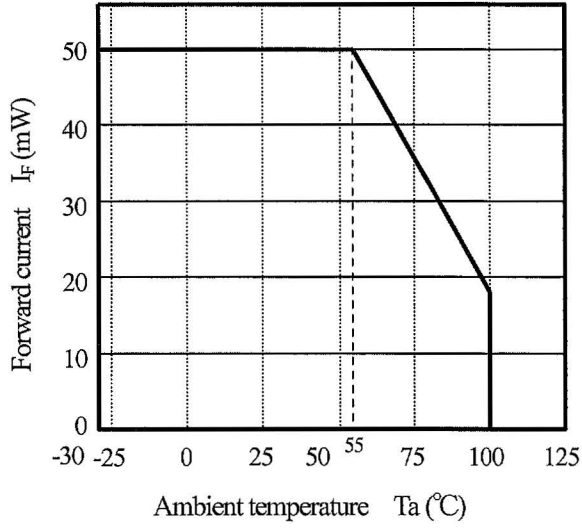

(Fig. 2) Collector power dissipation vs. ambient temperature

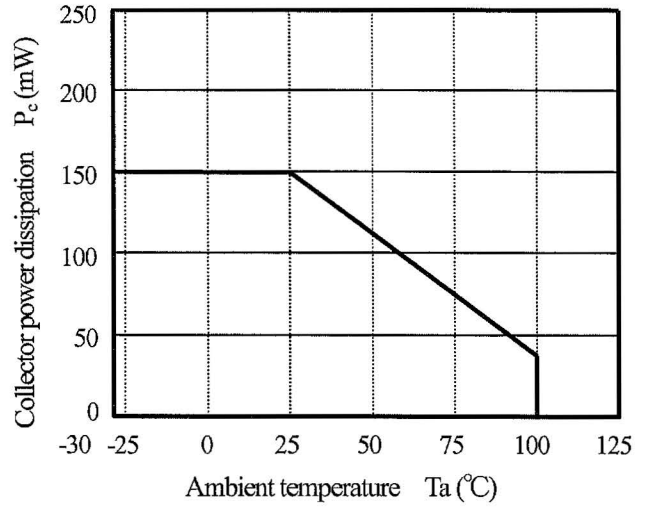

4. Reliability

The reliability of products shall satisfy items listed below.

Test item as require

| Test title | Test condition |
|--|---|
| Pre-condition test | 125°C=24h, 85°C 85%RH=168h, and IR reflow 260°C peak=3Cycles |
| Temperature cycling test | Ta=-55~125°C, Dwell time=15min per zone, 1000 cycles |
| Room temperature operation life test | Ta=25°C, I _F =50mA, 1000h |
| High temperature operation life test | Ta=110°C, I _F =20mA, P _C =22.5mW, 1000h |
| High temperature & high humidity bias test | Ta=85°C, 85%RH, V _{CE} =64V(=BV _{CEO} × 4/5), 1000h |
| High temperature bias test | Ta=110°C, V _{CE} =80V, 1000h |
| High temperature storage test | Ta=150°C, 1000h |
| Low temperature storage test | Ta=-55°C, 1000h |
| Autoclave | Temperature=121°C, 100%RH and 15Psi, 168h |

Specification of product for reliability

Ta=25°C

| Parameter | Symbol | Mesurement condition | MIN. | MAX. | Unit |
|--------------------------------------|----------------------|---|------|------|------|
| Forward voltage | V _F | I _F =20mA | - | 1.4 | V |
| Reverse current | I _R | V _R =4V | - | 10 | μA |
| Dark current | I _{CEO} | V _{CE} =50V | - | 100 | nA |
| Collector-emitter breakdown voltage | BV _{CEO} | I _C =0.1mA | 80 | - | V |
| Emitter-collector breakdown voltage | BV _{ECO} | I _E =10 μA | 6 | - | V |
| Collector-emitter saturation voltage | V _{CE(sat)} | I _F =20mA, I _C =1mA | - | 0.2 | V |
| Current Transfer Ratio | CTR | I _F =5mA, V _{CE} =5V | 50 | 400 | % |

Reliability judgment criteria

| Symbol | Failure Judgment Criteria | |
|----------------------|----------------------------------|--|
| V _F | U.S.L. × 1.5 < V _F | U.S.L. : Upper reliability specification limit L.S.L. : Lower reliability specification limit |
| I _R | U.S.L. < I _R | |
| BV _{CEO} | BV _{CEO} < L.S.L. × 0.5 | |
| BV _{ECO} | BV _{ECO} < L.S.L. × 0.5 | |
| CTR | CTR < L.S.L. × 0.5 | |
| I _{CEO} | U.S.L. < I _{CEO} | |
| V _{CE(sat)} | U.S.L. < V _{CE(sat)} | |

Short and open is criteria of Temperature cycling test and Autoclave item.

5. Outgoing inspection

5.1 Inspection items

(1) Appearance

5.2 Sampling method and Inspection level

A single sampling plan, normal inspection level II based on ISO 2859 is applied.

The AQL according to the inspection items are shown below.

| Defect | Inspection item | AQL (%) |
|--------------|---|---------|
| Major defect | Unreadable marking | 0.15 |
| Minor defect | Appearance defect except the above mentioned. | 0.65 |

6.2 Packing specification

6.2.1 Package materials

| Name | Materials |
|-----------------------------|---------------------------|
| Sleeve | PS |
| Stopper | TPR(Thermoplastic rubber) |
| Packing case (Inner box) | Paper |
| Packing case (Outer carton) | |

6.2.2 Packing data

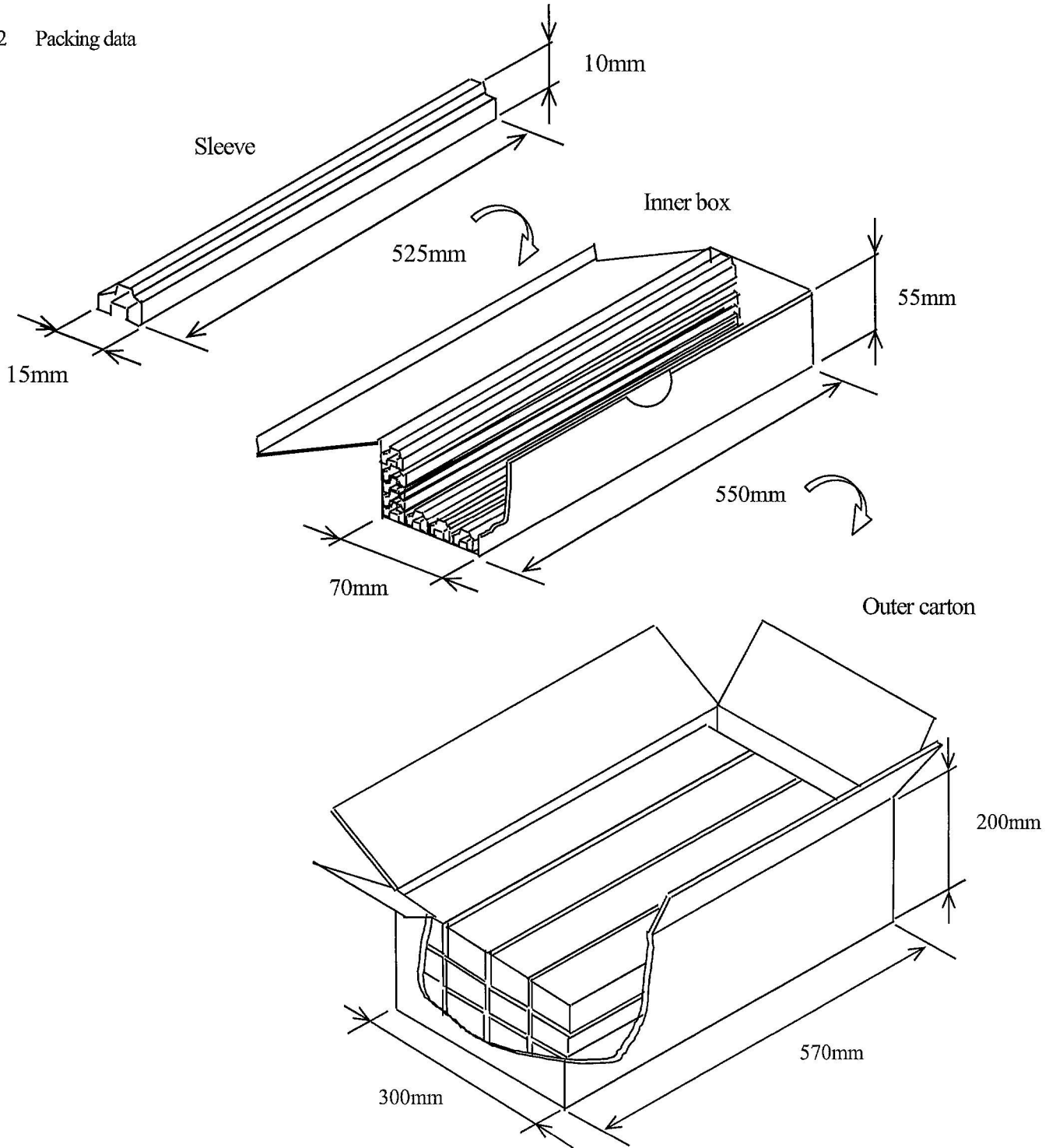

| Sleeve volume (pcs/sleeve) | Inner box volume (sleeve/box) | Outer carton volume (box/carton) | Total volume (pcs/outer carton) |
|----------------------------|-------------------------------|----------------------------------|---------------------------------|
| 100 | 20 | 12 | 24000 |

6.2.3 Sleeve and Stopper data

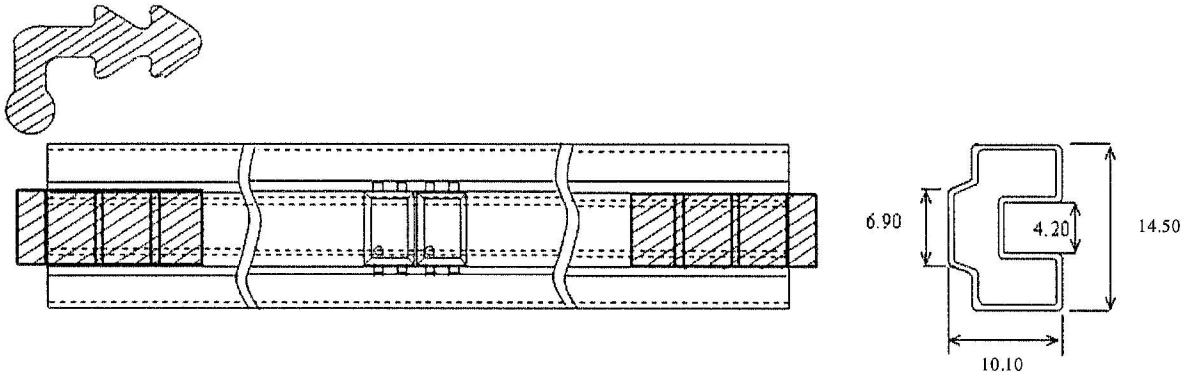

All dimensions are in millimeters.

Precautions for Photocouplers

1. Cleaning

- (1) Solvent cleaning : Solvent temperature 45°C or less
Immersion for 3 min or less
- (2) Ultrasonic cleaning : The effect to device by ultrasonic cleaning differs by cleaning bath size, ultrasonic power output, cleaning time, PCB size or device mounting condition etc. Please test it in actual using condition and confirm that any defect doesn't occur before starting the ultrasonic cleaning.
- (3) Applicable solvent : Ethyl alcohol, Methyl alcohol, Isopropyl alcohol
When the other solvent is used, there are cases that the packaging resin is eroded.
Please use the other solvent after thorough confirmation is performed in actual using condition.

2. Circuit design

- 2.1 The LED used in the Photocoupler generally decreases the light emission power by operation.
In case of long operation time, please design the circuit in consideration of the degradation of the light emission power of the LED. (50%/5years)
- 2.2 There are cases that the deviation of the CTR and the degradation of the relative light emission power of the LED increase when the setting value of I_F is less than 1.0mA. Please design the circuit in consideration of this point.

3. Precautions for Soldering

- (1) In the case of flow soldering (Avoid immersing units body in the solder)
One time soldering is recommended within the condition of temperature.
Temperature: 260+0/-5°C
Time: 10 sec.
Preheat temperature: 25 to 140°C
Preheat time: 30 to 80 sec

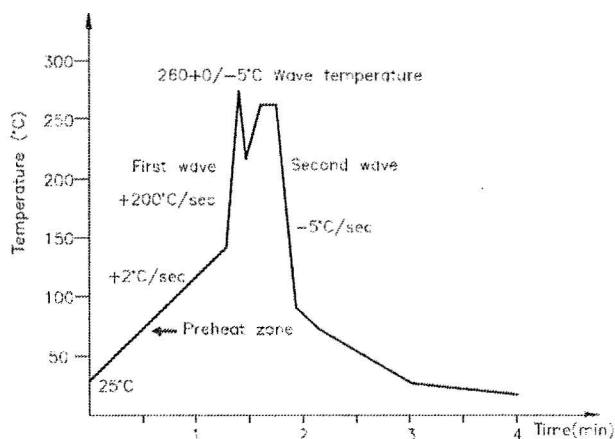

- (2) In the case of hand soldering by soldering iron
Allow single lead soldering in every single process. One time soldering is recommended.
Temperature: 380+0/-5°C
Time: (max.) 3s
- (3) Other precautions
Depending on equipment and soldering conditions (temperature, Using solder etc.), the effect to the device and the PCB is different.
Please confirm that there is no problem on the actual use conditions in advance.