



Chipsmall Limited consists of a professional team with an average of over 10 year of expertise in the distribution of electronic components. Based in Hongkong, we have already established firm and mutual-benefit business relationships with customers from,Europe,America and south Asia,supplying obsolete and hard-to-find components to meet their specific needs.

With the principle of "Quality Parts,Customers Priority,Honest Operation,and Considerate Service",our business mainly focus on the distribution of electronic components. Line cards we deal with include Microchip,ALPS,ROHM,Xilinx,Pulse,ON,Everlight and Freescale. Main products comprise IC,Modules,Potentiometer,IC Socket,Relay,Connector.Our parts cover such applications as commercial,industrial, and automotives areas.

We are looking forward to setting up business relationship with you and hope to provide you with the best service and solution. Let us make a better world for our industry!



## Contact us

Tel: +86-755-8981 8866 Fax: +86-755-8427 6832

Email & Skype: info@chipsmall.com Web: www.chipsmall.com

Address: A1208, Overseas Decoration Building, #122 Zhenhua RD., Futian, Shenzhen, China



ALL MATERIALS AND FINISHES SHALL BE COMPLIANT TO RoHS 2011/65/EU DIRECTIVE.  
CERTIFICATE OF COMPLIANCE REQUIRED

**PC2441**

2 AXIS, 1 BUTTON PENDANT CONTROLLER CONSISTING OF:

- (1) ERGONOMIC, HIGH IMPACT PLASTIC HOUSING
- (1) 2 AXIS THUMBSTICK
- (1) MOMENTARY PUSHBUTTON

HID USB OUTPUT IS DEFINED AS A "GAME CONTROLLER" WITH A PID OF 0X005e AND A VID OF 0X68E.

USB 1.0, USB 2.0 COMPATIBLE.

**MECHANICAL SPECIFICATIONS**

**X / Y AXES**

OPERATING FORCE: 3.1N ± 0.5N  
MAX VERTICAL LOAD: 200N  
MAX HORIZONTAL LOAD: 150N  
ANGLE OF MOVEMENT: 50°  
EXPECTED LIFE: 1M CYCLES

**MOMENTARY SWITCHES**

OPERATING FORCE: 4.0N ± 3N  
EXPECTED LIFE: 1M CYCLES

**ELECTRICAL SPECIFICATIONS**

SUPPLY VOLTAGE: 5.0V ± .25V  
SUPPLY CURRENT: 60mA(TYPICAL) @ 5V

**ENVIRONMENTAL SPECIFICATIONS**

ENVIRONMENTAL SEALING: IP54  
OPERATING TEMPERATURE: -40°C to 85°C

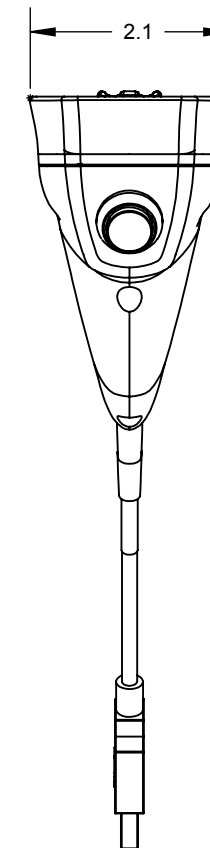
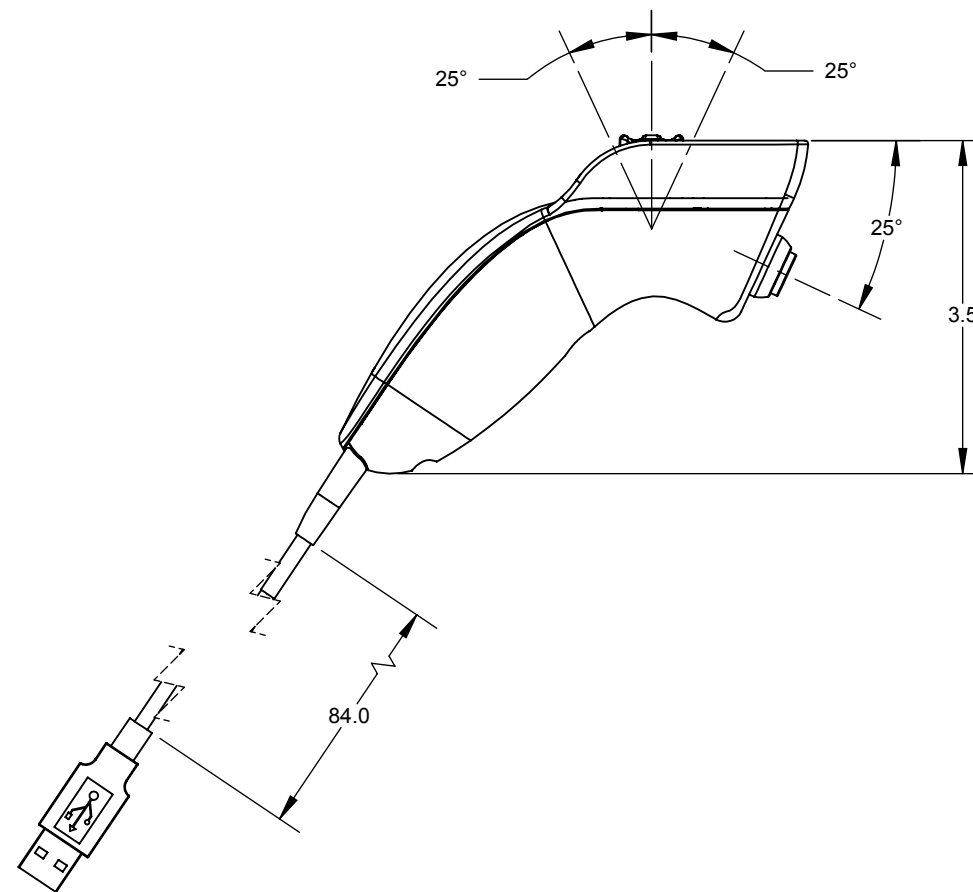
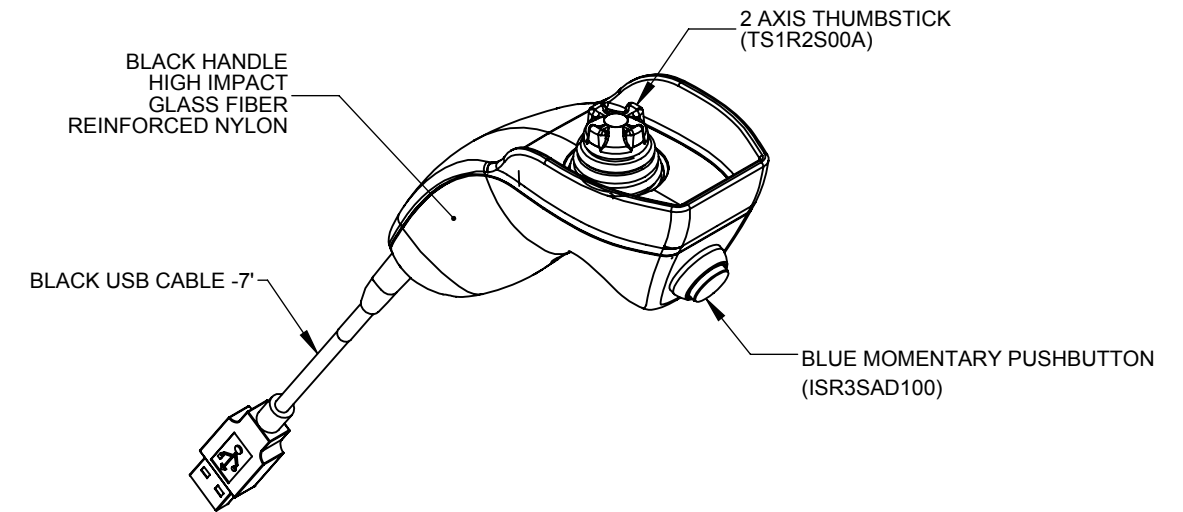
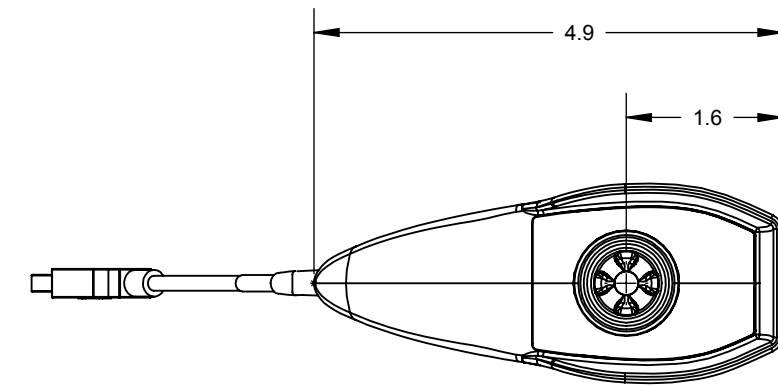

REV.	DESCRIPTION	DATE	ECN
A	INITIAL RELEASE	12/17/15	3909
B	UPDATED PB SPECS, ADDED APEM PNS	01/27/16	3964

CUSTOMER APPROVALS

COMPANY: \_\_\_\_\_

CUSTOMER APPROVAL SIGNATURE DATE

PRINTED NAME

		NUMBER: <b>PC2441</b>	
		DESCRIPTION: <b>2 AXIS 1 BUTTON PENDANT CONTROLLER</b>	REV: <b>B</b>
<small>UNLESS OTHERWISE SPECIFIED: DIMENSIONS ARE IN INCHES TOL. ON ANGLE ± 1.0° .XX ± 0.01 .XXX ± 0.003 .XXXX ± 0.001 INTERPRET DIM AND TOL PER ANSI Y14.5</small>		<small>CRITICAL DIMENSION</small>	
DRAWN BY: GT	CHECKED BY: ---	DESIGNED BY: ---	TYPE: M
DATE: 12/17/15	DATE: --	DATE: --	SIZE: B
SCALE: 1:2		3RD ANGLE PROJECTION	