



Chipsmall Limited consists of a professional team with an average of over 10 year of expertise in the distribution of electronic components. Based in Hongkong, we have already established firm and mutual-benefit business relationships with customers from,Europe,America and south Asia,supplying obsolete and hard-to-find components to meet their specific needs.

With the principle of “Quality Parts,Customers Priority,Honest Operation,and Considerate Service”,our business mainly focus on the distribution of electronic components. Line cards we deal with include Microchip,ALPS,ROHM,Xilinx,Pulse,ON,Everlight and Freescale. Main products comprise IC,Modules,Potentiometer,IC Socket,Relay,Connector.Our parts cover such applications as commercial,industrial, and automotives areas.

We are looking forward to setting up business relationship with you and hope to provide you with the best service and solution. Let us make a better world for our industry!



## Contact us

Tel: +86-755-8981 8866 Fax: +86-755-8427 6832

Email & Skype: info@chipsmall.com Web: www.chipsmall.com

Address: A1208, Overseas Decoration Building, #122 Zhenhua RD., Futian, Shenzhen, China





# PCA9521

## Fast dual bidirectional bus buffer

Rev. 2 — 19 March 2013

Product data sheet

## 1. General description

---

The PCA9521 is a monolithic bipolar integrated circuit for bus buffering in applications including I<sup>2</sup>C-bus, SMBus, PMBus, and other systems based on similar principles.

The buffer extends the bus load limit by buffering both the SCL and SDA lines. It supports up to 400 pF loads on each side of the buffer at 400 kHz. Higher capacitance is supported at lower speeds, and lower capacitance at higher speeds up to 1 MHz.

The enable function allows sections of the bus to be isolated. Individual parts of the system can be brought on-line successively. This means a controlled start-up using a diverse range of components, operating speeds and loads is easily achieved. Systems employing removable components on a back-plane (for example, telecommunications racks) can use the enable pin and the high-impedance ports on power-down to safely install and remove components in active systems.

Bus level translation between a very wide range of bus voltages, from 1.8 V to 10 V, is supported. This feature provides enormous flexibility in interfacing systems of different technologies.

The unique operation of the PCA9521 provides one of the fastest response times of such bidirectional buffers, ensuring any glitches (common to other buffers) are kept well within the 50 ns I<sup>2</sup>C-bus specification. Additionally, it does this without the need for 'rise-time accelerators' which, combined with low noise margins, may cause glitches outside of the I<sup>2</sup>C-bus specification.

## 2. Features and benefits

---

- Dual, bidirectional unity gain buffer
- Fast switching times allow operation in excess of 1 MHz
- Supports I<sup>2</sup>C-bus (Standard-mode and Fast-mode), SMBus (standard and high power mode), PMBus and IPMB
- Enable allows bus segments to be disconnected
- Low standby current when not enabled
- Application/removal of power to IC will not interfere with other bus activity
- 6 mA (static) pull-down capability supports a wide range of bus standards
- Low noise susceptibility
- Low input-output offset voltage
- Threshold and offset parameters allow the connection of several devices in series
- Bus levels independent of supply voltage
- Operating voltages from 2.7 V to 5.5 V
- Wide range of bus voltages from 1.8 V to 10 V



- Level shifting between different bus voltages
- Achieves superior response times without the need for rise time accelerators
- ESD protection exceeds 2 kV HBM per JESD22-A114 and 500 V CDM per JESD22-C101
- Latch-up testing is done to JEDEC Standard JESD78 which exceeds 100 mA

### 3. Applications

- Power management systems
- Telecommunications systems including ATCA
- Desktop and portable computers including RAID
- Building automation
- TV/projector/monitor interconnection
- Game consoles/boxes
- CompactPCI
- Medical systems
- Gaming machine networks
- Backplane management/interconnect

### 4. Ordering information

Table 1. Ordering information

Type number	Topside marking	Package		
		Name	Description	Version
PCA9521D	PCA9521	SO8	plastic small outline package; 8 leads; body width 3.9 mm	SOT96-1
PCA9521DP	9521	TSSOP8	plastic thin shrink small outline package; 8 leads; body width 3 mm	SOT505-1

#### 4.1 Ordering options

Table 2. Ordering options

Type number	Orderable part number	Package	Packing method	Minimum order quantity	Temperature range
PCA9521D	PCA9521D,118	SO8	Reel 13" Q1/T1 *standard mark SMD	2500	T <sub>amb</sub> = -40 °C to +85 °C
PCA9521DP	PCA9521DP,118	TSSOP8	Reel 13" Q1/T1 *standard mark SMD	2500	T <sub>amb</sub> = -40 °C to +85 °C

## 5. Block diagram

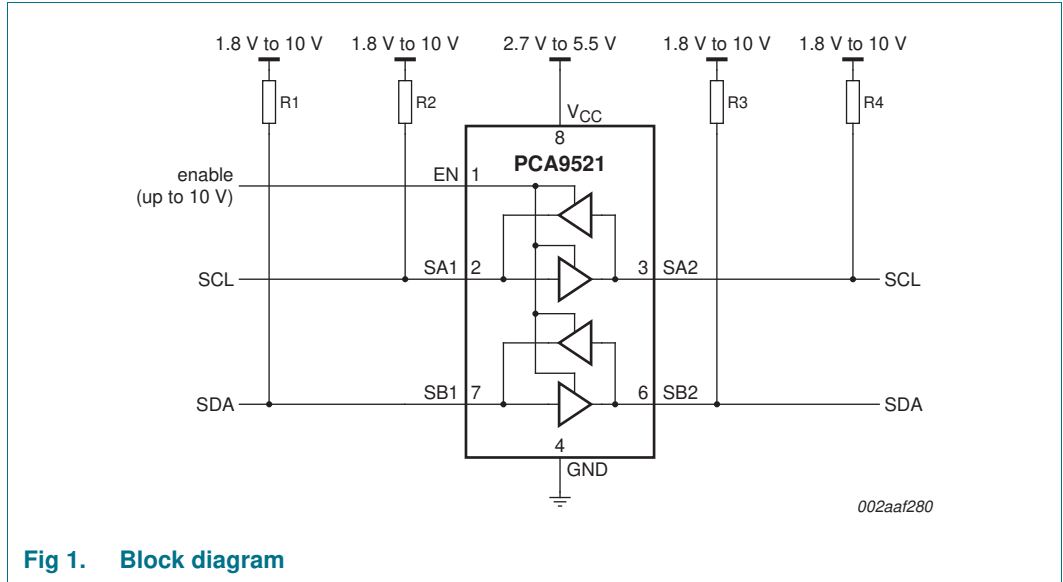

Fig 1. Block diagram

## 6. Pinning information

### 6.1 Pinning

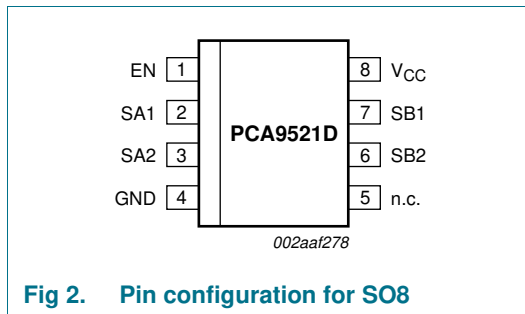

Fig 2. Pin configuration for SO8

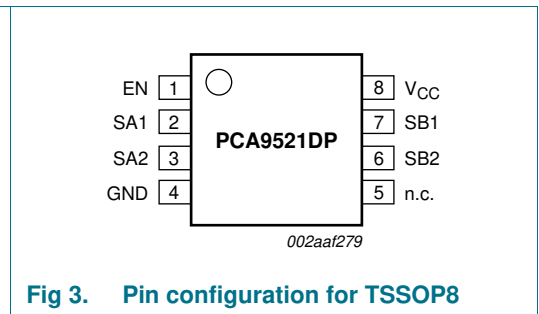

Fig 3. Pin configuration for TSSOP8

### 6.2 Pin description

Table 3. Pin description

Symbol	Pin	Description
EN	1	enable
SA1	2	buffer A, port 1 (SCL output <sup>[1]</sup> )
SA2	3	buffer A, port 2 (SCL input <sup>[1]</sup> )
GND	4	supply ground
n.c.	5	not connected
SB2	6	buffer B, port 2 (SDA input <sup>[1]</sup> )
SB1	7	buffer B, port 1 (SDA output <sup>[1]</sup> )
V <sub>CC</sub>	8	positive supply

[1] Recommended I<sup>2</sup>C-bus orientation for device family compatibility.

## 7. Functional description

Refer to [Figure 1 “Block diagram”](#).

### 7.1 $V_{CC}$ , GND — supply pins

The power supply voltage for the PCA9521 may be any voltage in the range 2.7 V to 5.5 V. The threshold level below which the output will begin to match the input is 33 % of  $V_{CC}$ . Hence, the operating voltage should be chosen with the required bus voltage, switching threshold, and noise margins, in mind.

### 7.2 SA1, SA2, SB1, SB2 — buffer inputs/outputs

The two buffers (SA and SB) are identical and symmetrical. The buffers can be driven from either direction, with the same response. When port 1 of the buffer is being driven LOW ( $< 0.3V_{CC}$ ) by another device on the bus, port 2 will be driven LOW by the IC to provide the buffered output.

The ‘input’ side is determined by the lowest externally driven signal. Therefore if port 1 is externally pulled to  $V_{Sx1} = 250$  mV, and port 2 is externally pulled to  $V_{Sx2} = 500$  mV, the buffer will pull port 2 down further such that it becomes  $V_{Sx2} = V_{Sx1} + V_{offset}$ . Should port 2 subsequently become lower than port 1 by the amount of the offset voltage ( $V_{Sx2} + V_{offset} < V_{Sx1}$ ) by means of an external device pulling it LOW, control of the buffering operation will switch, and port 2 will become the ‘input’. The voltage at port 1 will then become  $V_{Sx1} = V_{Sx2} + V_{offset}$ . When both ports are being held almost equal (less than an offset voltage) the external devices are effectively in control.

### 7.3 EN — enable; activate buffer operations

The enable input, EN, is used to disable the buffer, for the purpose of isolating sections of the bus. The IC should only be disabled when the bus is idle. This prevents truncation of commands which may confuse other devices on the bus.

Enable may also be used to progressively activate sections of the bus during system start-up. Bus sections slow to respond on power-up can be kept isolated from the main system to avoid interference and collisions.

The EN pin may be pulled up higher than the  $V_{CC}$  of the buffer, further enhancing the capability of the PCA9521 in a level shifting role. For example, a microprocessor could drive EN, SA1 and SB1 at 5 V, while the buffer  $V_{CC}$ , SA2 and SB2 ports are at 3.3 V.

Similarly, the threshold level of the EN pin allows a 1.8 V device to disable a PCA9521 with a  $V_{CC}$  of 3.3 V.

The EN pin includes an internal 2  $\mu$ A pull-down current, which will act to disable the device should the pin be left floating.

## 8. Limiting values

**Table 4. Limiting values**

In accordance with the Absolute Maximum Rating System (IEC 60134).

Symbol	Parameter	Conditions	Min	Max	Unit
$V_{CC}$	supply voltage		[1] -0.3	+7	V
$V_n$	voltage on any other pin	SA1, SA2, SB1, SB2	[1] -0.3	+12	V
$V_{I(EN)}$	input voltage on pin EN		[1] -0.3	+12	V
$I_{IO}$	input/output current	any pin	-	20	mA
$P_{tot}$	total power dissipation		-	300	mW
$T_{stg}$	storage temperature		-55	+125	°C
$T_{amb}$	ambient temperature	operating	-40	+85	°C

[1] Voltages are specified with respect to pin 4 (GND).

## 9. Characteristics

**Table 5. Characteristics**

$T_{amb} = -40\text{ °C}$  to  $+85\text{ °C}$ ; voltages are specified with respect to ground (GND).

Symbol	Parameter	Conditions	Min	Typ	Max	Unit
<b>Power supply</b>						
$V_{CC}$	supply voltage	operating	2.7	-	5.5	V
$I_{CC}$	supply current	operating; $V_{CC} = V_{I(EN)} = 5.5\text{ V}$	-	6	-	mA
		standby; $V_{CC} = 5.5\text{ V}$ ; $V_{I(EN)} = 0\text{ V}$	-	670	900	μA
<b>Buffer ports (SA1, SA2, SB1, SB2)</b>						
$V_{bus}$	bus voltage		1.8	-	10	V
$V_{th(IL)}$	LOW-level input threshold voltage		-	-	$0.3V_{CC}$	V
$V_{th(IH)}$	HIGH-level input threshold voltage		$0.41V_{CC}$	-	-	V
$I_{IL}$	LOW-level input current	drive current; $V_{bus} < V_{CC}$	-	-6	-20	μA
$I_{O(sink)}$	output sink current	LOW-level; $V_{bus(out)} = 0.4\text{ V}$	6	-	-	mA
$V_{offset}$	offset voltage	input/output; $V_{CC} = 5\text{ V}$				
		$I_{OL} = 5\text{ mA}$ ; $V_{bus(in)} = 50\text{ mV}$	-	230	300	mV
		$I_{OL} = 500\text{ μA}$ ; $V_{bus(in)} = 50\text{ mV}$	-	90	125	mV
		$I_{OL} = 1.2\text{ mA}$ ; $V_{bus(in)} = 200\text{ mV}$	-	90	125	mV
$I_L$	leakage current	$V_{bus} \geq V_{CC}$	-	-	5	μA
$C_{io}$	input/output capacitance		[1] -	-	10	pF
<b>Enable (EN)</b>						
$V_{en}$	enable voltage	active	1.3	-	-	V
$V_{dis}$	disable voltage	standby	-	-	0.7	V
$I_I$	input current	$V_{en} > 1.2\text{ V}$	0.7	-	5	μA

**Table 5. Characteristics ...continued**

$T_{amb} = -40\text{ }^{\circ}\text{C}$  to  $+85\text{ }^{\circ}\text{C}$ ; voltages are specified with respect to ground (GND).

Symbol	Parameter	Conditions	Min	Typ	Max	Unit
<b>Timing characteristics[1]</b>						
$t_d$	delay time	$V_{CC} = 5\text{ V}$ ; $V_{bus} = 5\text{ V}$ ; $R_{pu(bus)} = 1\text{ k}\Omega$ ; $C_{L(ext)} = 120\text{ pF}$ ; <a href="#">Figure 4</a>	-	45	-	ns
$t_f$	fall time	$V_{CC} = 5\text{ V}$ ; $V_{bus} = 5\text{ V}$ ; $R_{pu(bus)} = 1\text{ k}\Omega$ ; $C_{L(ext)} = 120\text{ pF}$ ; <a href="#">Figure 4</a>	-	40	-	ns
$f_{oper(I2C)}$	I <sup>2</sup> C operating frequency		0	-	1000	kHz
$t_{d(en-act)}$	enable to active delay time	EN HIGH to Sxx active	-	1.5	-	$\mu\text{s}$
$t_{d(dis-stb)}$	disable to standby delay time	EN LOW to Sxx disabled	-	0.4	-	$\mu\text{s}$

[1] Guaranteed by design (not subject to test).

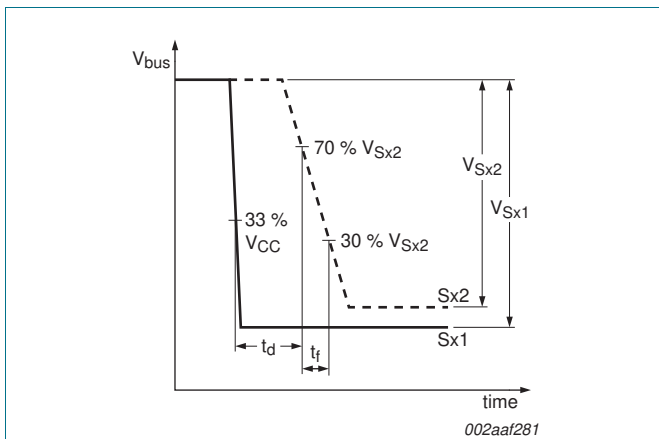

**Fig 4. Timing parameters**

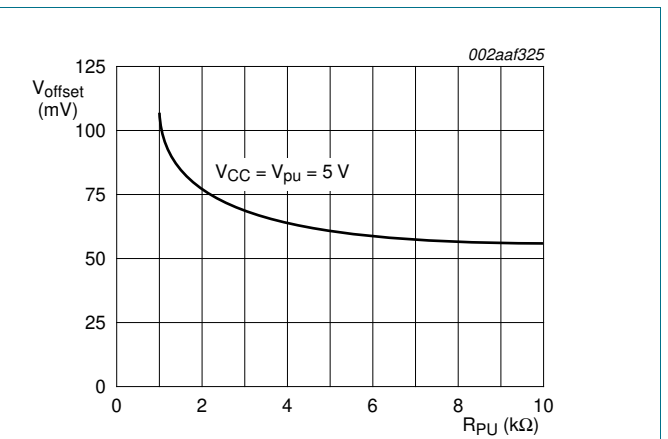

**Fig 5. Offset voltage,  $V_O - V_I$**

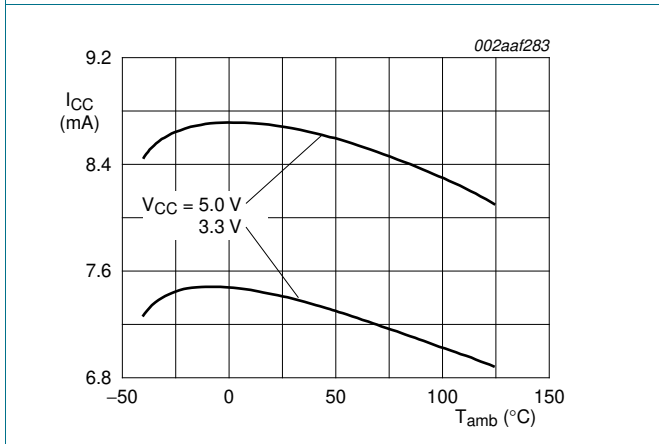

**Fig 6. Supply current versus ambient temperature**

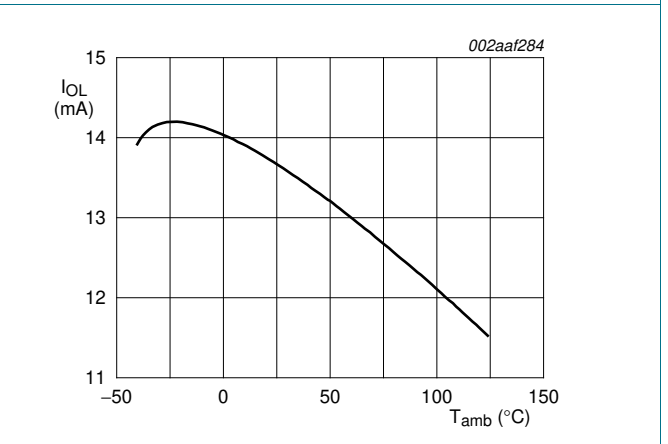

**Fig 7. LOW-level output current versus ambient temperature**

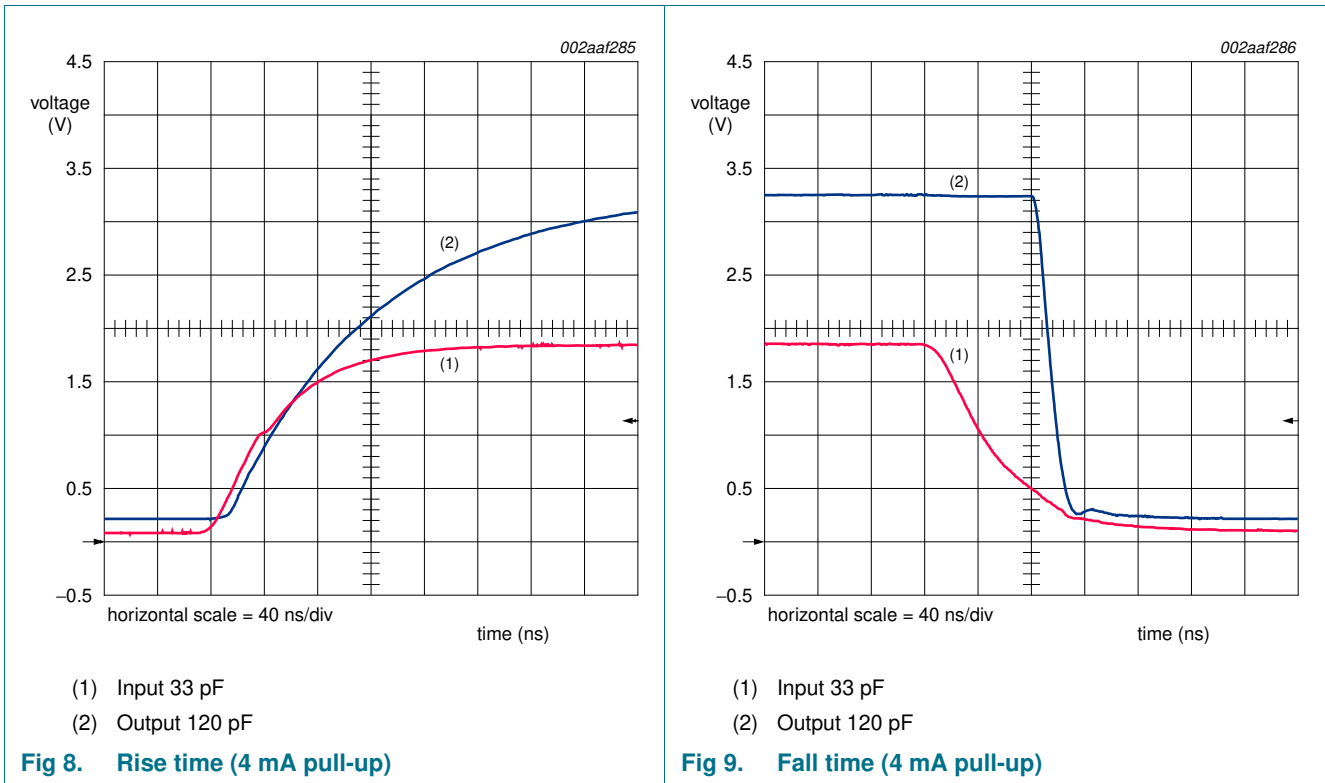



## 10. Application information

### 10.1 Design considerations

Figure 10 shows the PCA9521 level shifting signals from 1.8 V to 3.3 V at 1 MHz clock speed. The PCA9521 has excellent application to extending loads and providing interfaces to connectors on high-speed microprocessor cards, well in excess of the Fast-mode 400 kHz I<sup>2</sup>C-bus specification. Rise times are determined simply by the side of the buffer with the slowest RC time constant.

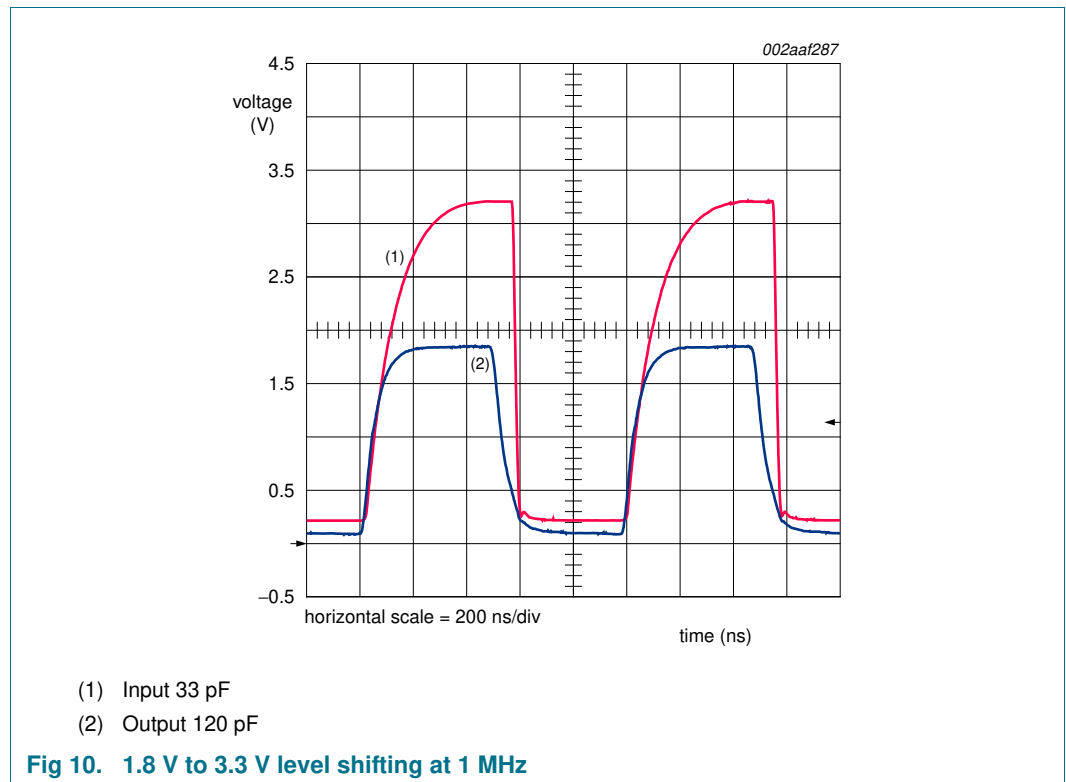

Figure 11 shows a typical application for the PCA9521. The IC can level shift between different bus voltages without the need for external components. Higher bus voltages and currents outside the range of the Standard-mode I<sup>2</sup>C-bus specification can be catered for, providing a longer range capability and higher noise immunity.

The enable pin (EN) can be used to interface buses of different operating frequencies. When certain bus sections are enabled, the system frequency may be limited by a bus section having a slave device specified only to 100 kHz. When that bus section is disabled, the slow slave is isolated and the remaining bus can be run at 400 kHz. The timing performance and current sinking capability will allow the PCA9521 to run well in excess of the 400 kHz maximum limit of the Fast-mode I<sup>2</sup>C-bus.

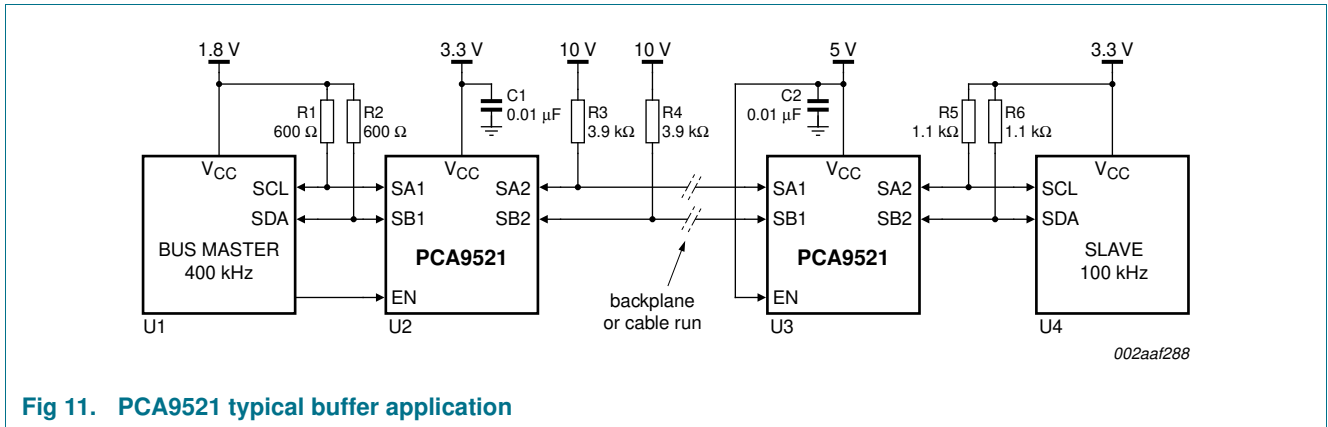
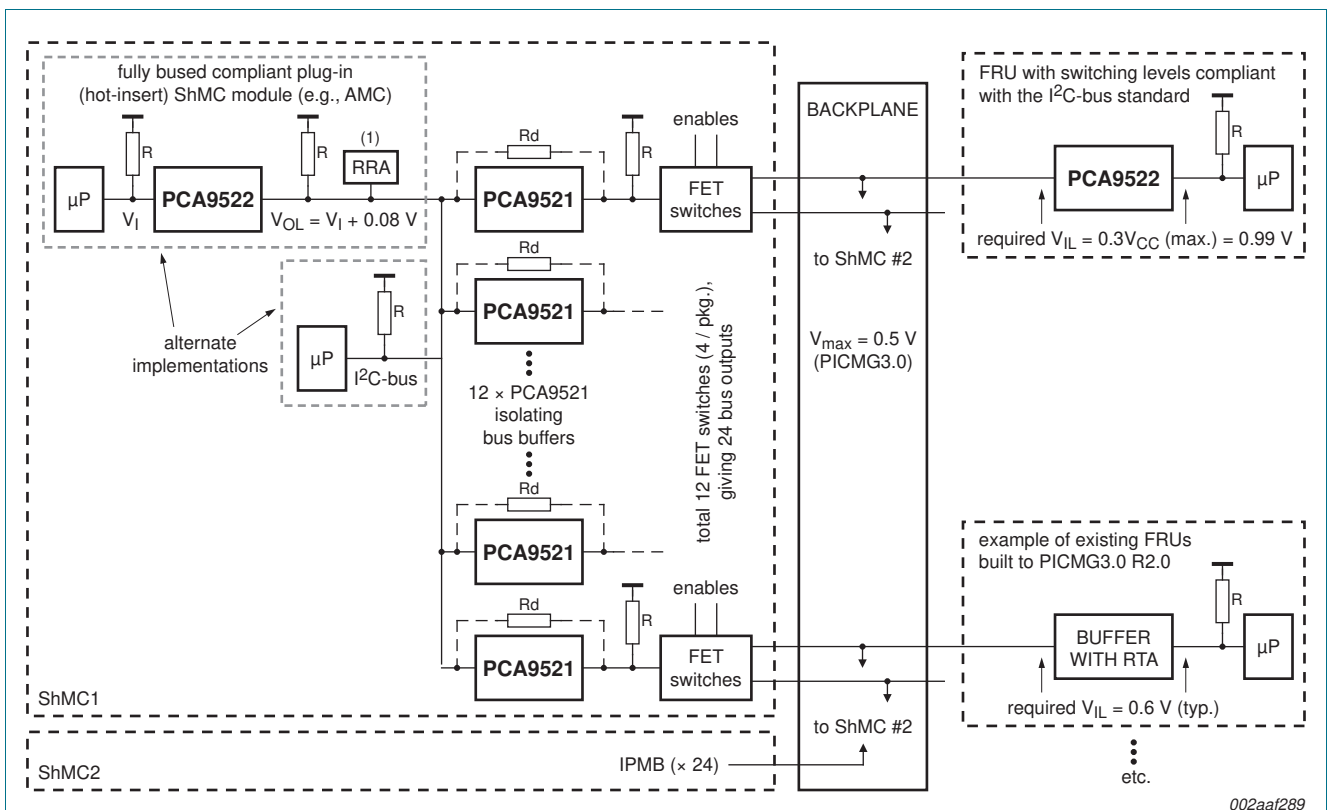

Fig 11. PCA9521 typical buffer application

Figure 12 shows the PCA9521 used in a radial (star) configuration on an AdvancedTCA Shelf Management Controller board (ShMC). The PCA9521 is highly suited to this and other backplane applications, providing excellent noise margins and I<sup>2</sup>C-bus compliant switching levels.



The system shown here uses FET switches, however a valid alternative is to simply use 24 × PCA9521's without FET switches. Long track runs on the ShMC board and backplane can sometimes result in high frequency tuned circuits on either side of the PCA9521. If your layout is prone to forming such tuned circuits, it is perfectly acceptable to use a 'traditional' damping resistor (R<sub>d</sub>) across the PCA9521.

(1) RRA = Rise Rate Accelerator.

Fig 12. AdvancedTCA style backplane application using PCA9521 in a radial Shelf Manager configuration

Peripheral cards (or FRU (Field Replaceable Units)) and backplanes operating at a range of voltages can be interfaced together using a minimum of components. The PCA9521 can be teamed with the PCA9522 to achieve substantial noise margin gains across a system.

Multiplexers such as the PCA9544A are simple analog switches which provide no capacitive load isolation between connected branches. Figure 14 shows the PCA9521 enhancing an I<sup>2</sup>C-bus multiplexer application, by isolating the load capacitance of each branch. Figure 15 and Figure 16 show alternate forms of bus multiplexing.

Similarly, the P82B715 I<sup>2</sup>C-bus extender, which is commonly used for line driver applications, provides a '10× impedance transformation' but does not isolate either side of the buffer. Figure 13 shows the PCA9521 used to isolate the bus loading due to the P82B715. This greatly simplifies calculation of the pull-ups, increases the total system loading capability in extender applications, will meet the Fast-mode release requirement (when PCA9521 and P82B715 V<sub>CC</sub>'s share a common supply), and ensures the 300 ns rise time requirement can easily be met even if the cable bus rise is relatively slow.

Buffers are intended to extend total system capacitance above 400 pF, so anticipate high capacitance on each side. When loading on one side is small, adding 47 pF is suggested to avoid any waveform ripple, should it occur.

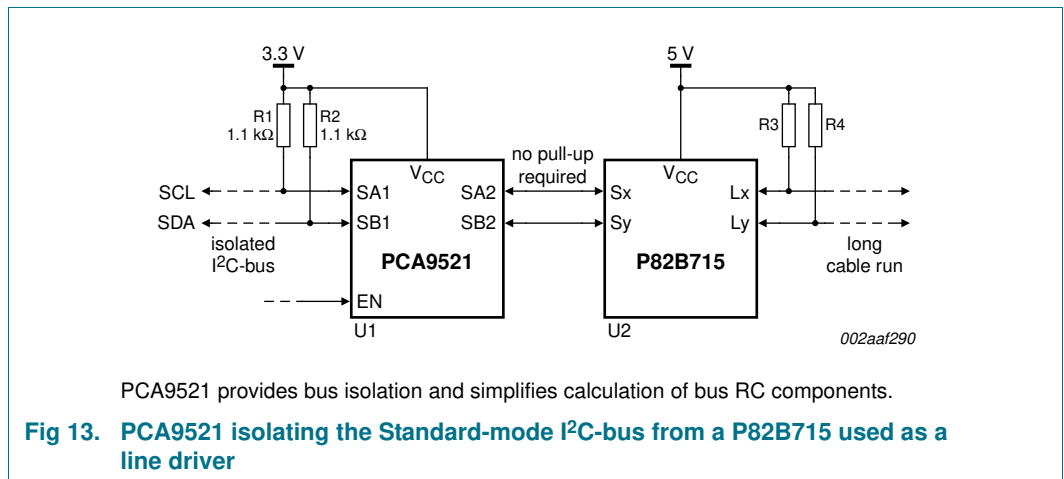

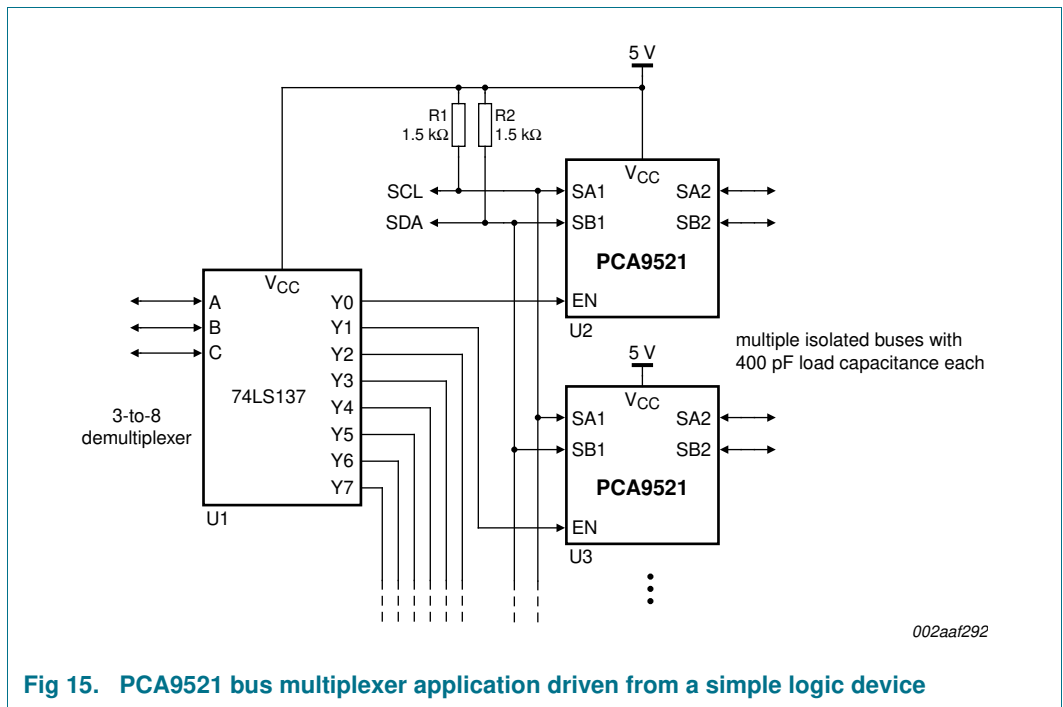
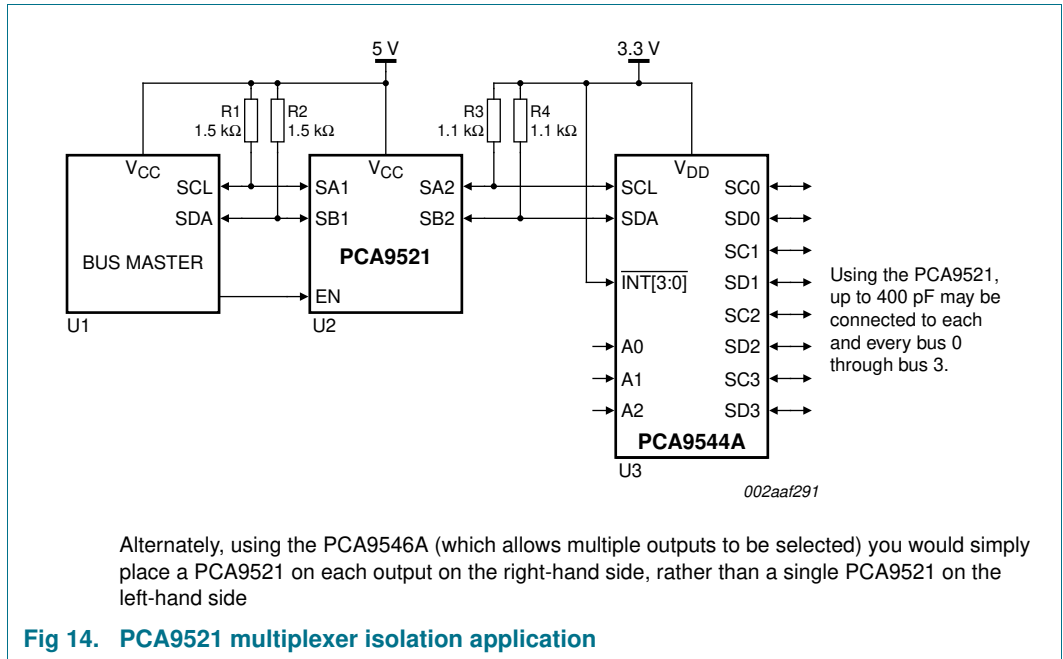

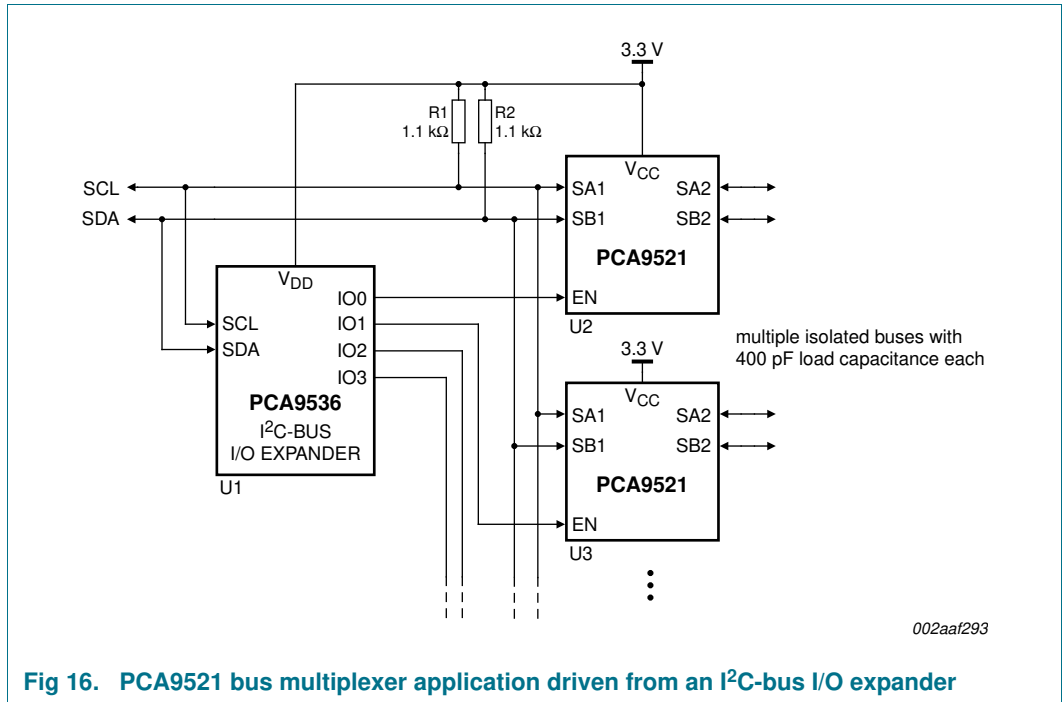

Fig 16. PCA9521 bus multiplexer application driven from an I<sup>2</sup>C-bus I/O expander

### 10.2 Input to output offset voltage calculation

The offset voltage between the side acting as the output (Sxx(out)) and the side acting as the input (Sxx(in)) of the PCA9521 can be calculated using the relationship given in [Equation 1](#):

$$V_{offset} = V_i + 50 \text{ mV} + \left( \frac{V_{BUS}}{R} \right) \times 11 \tag{1}$$

This calculation is valid for  $V_{bus(in)} \geq 200 \text{ mV}$ , as below this point the saturation voltage of the open-collector output drive transistor will begin to affect the characteristic. Input and output voltages are shown in millivolts,  $V_{BUS}$  (the supply voltage to the bus) is in volts, and R is in ohms.

An example calculation for  $V_{BUS} = 3.3 \text{ V}$ ,  $V_{SA1} = 200 \text{ mV}$ , the resistance R pulling up SA2 is 2 kΩ, then the voltage on SA2 is typically:

$$V_{SA2} = 200 \text{ mV} + 50 \text{ mV} + \left( \frac{3.3}{2000} \right) \times 11 = 268 \text{ mV} \tag{2}$$

This can be compared with the offset characteristic shown in [Figure 5](#).

### 11. Package outline

SO8: plastic small outline package; 8 leads; body width 3.9 mm

SOT96-1

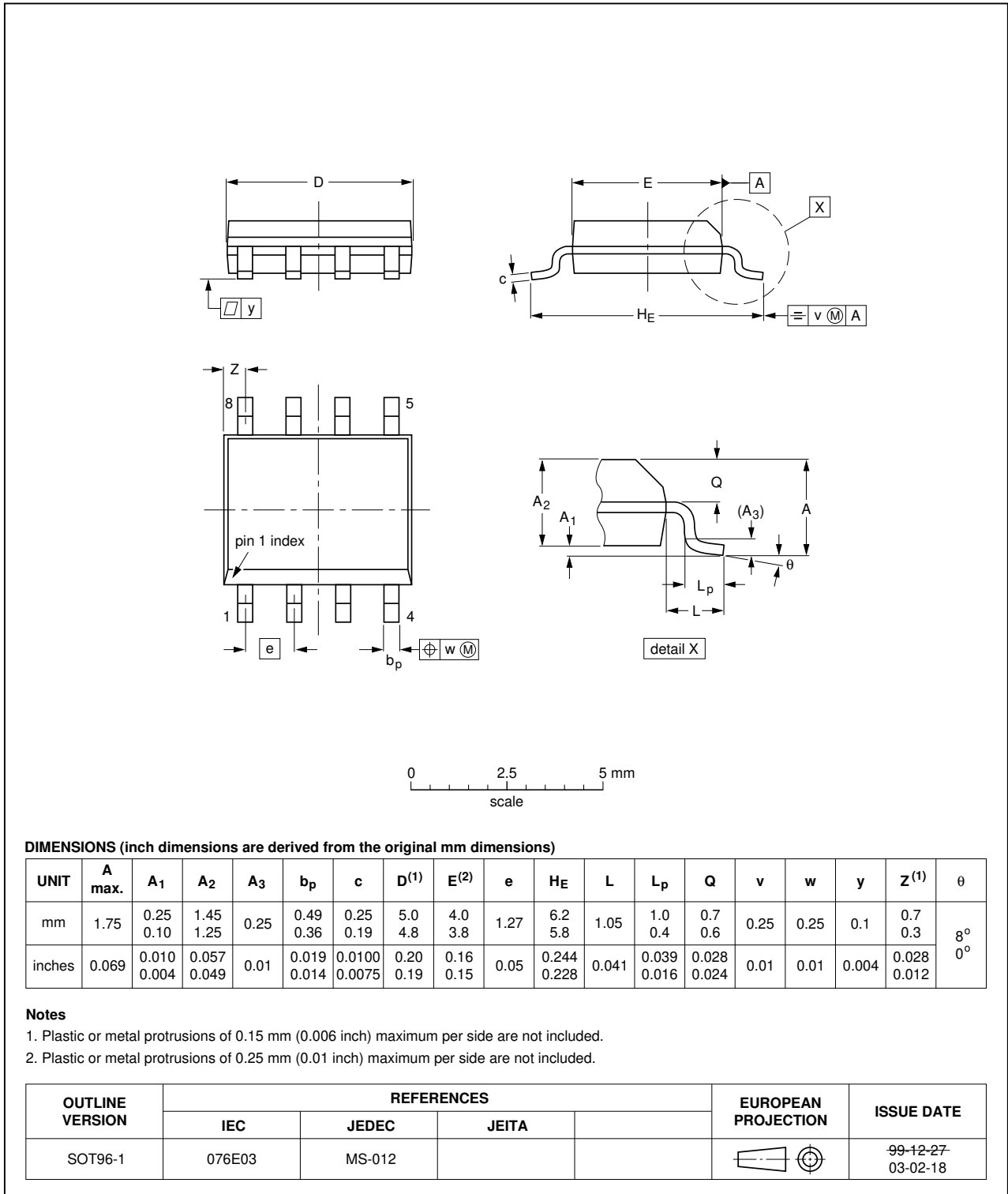

Fig 17. Package outline SOT96-1 (SO8)

TSSOP8: plastic thin shrink small outline package; 8 leads; body width 3 mm

SOT505-1

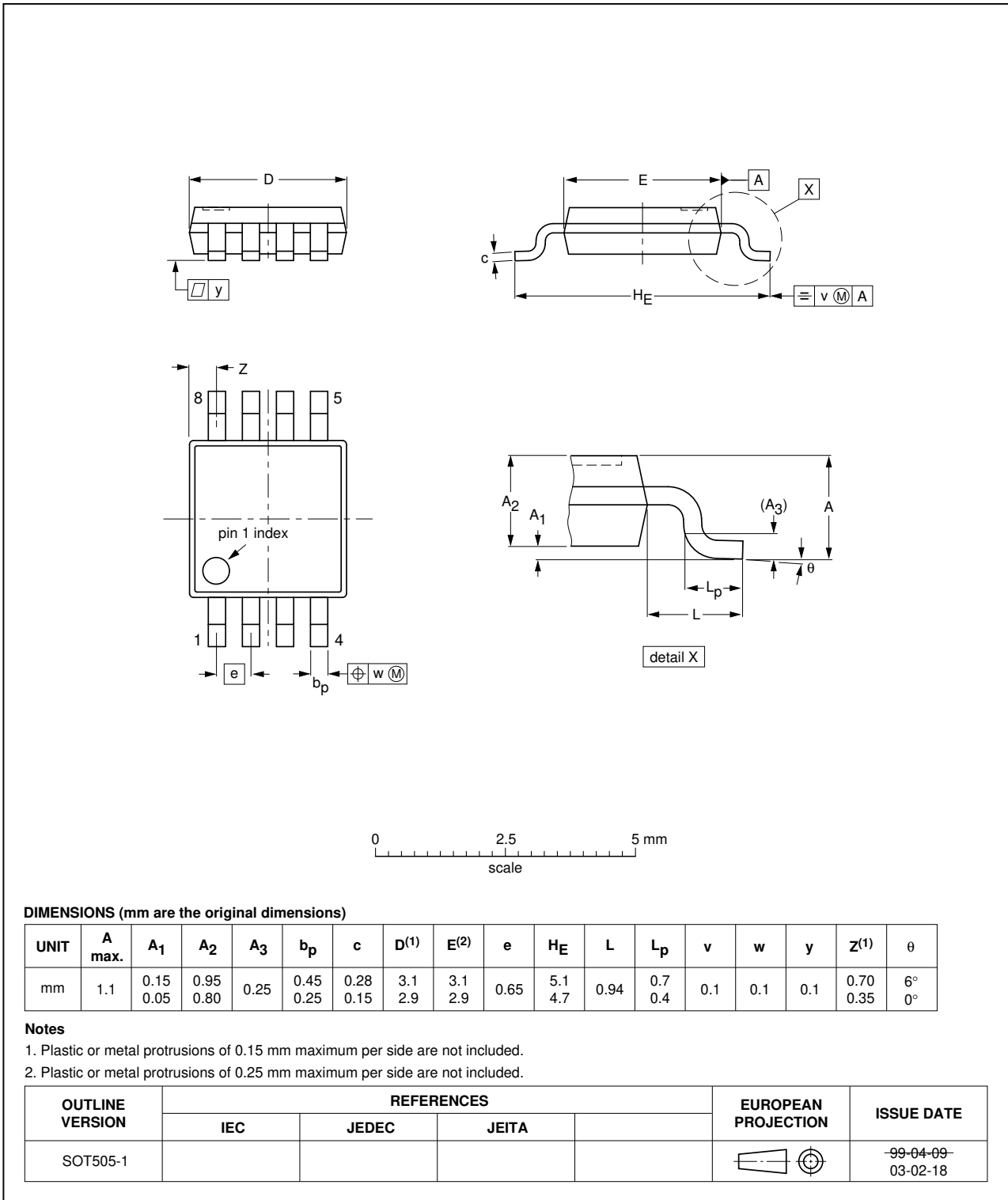

Fig 18. Package outline SOT505-1 (TSSOP8)

## 12. Handling information

### CAUTION



This device is sensitive to ElectroStatic Discharge (ESD). Observe precautions for handling electrostatic sensitive devices.

Such precautions are described in the *ANSI/ESD S20.20*, *IEC/ST 61340-5*, *JESD625-A* or equivalent standards.

## 13. Soldering of SMD packages

This text provides a very brief insight into a complex technology. A more in-depth account of soldering ICs can be found in Application Note *AN10365 "Surface mount reflow soldering description"*.

### 13.1 Introduction to soldering

Soldering is one of the most common methods through which packages are attached to Printed Circuit Boards (PCBs), to form electrical circuits. The soldered joint provides both the mechanical and the electrical connection. There is no single soldering method that is ideal for all IC packages. Wave soldering is often preferred when through-hole and Surface Mount Devices (SMDs) are mixed on one printed wiring board; however, it is not suitable for fine pitch SMDs. Reflow soldering is ideal for the small pitches and high densities that come with increased miniaturization.

### 13.2 Wave and reflow soldering

Wave soldering is a joining technology in which the joints are made by solder coming from a standing wave of liquid solder. The wave soldering process is suitable for the following:

- Through-hole components
- Leaded or leadless SMDs, which are glued to the surface of the printed circuit board

Not all SMDs can be wave soldered. Packages with solder balls, and some leadless packages which have solder lands underneath the body, cannot be wave soldered. Also, leaded SMDs with leads having a pitch smaller than ~0.6 mm cannot be wave soldered, due to an increased probability of bridging.

The reflow soldering process involves applying solder paste to a board, followed by component placement and exposure to a temperature profile. Leaded packages, packages with solder balls, and leadless packages are all reflow solderable.

Key characteristics in both wave and reflow soldering are:

- Board specifications, including the board finish, solder masks and vias
- Package footprints, including solder thieves and orientation
- The moisture sensitivity level of the packages
- Package placement
- Inspection and repair
- Lead-free soldering versus SnPb soldering



### 13.3 Wave soldering

Key characteristics in wave soldering are:

- Process issues, such as application of adhesive and flux, clinching of leads, board transport, the solder wave parameters, and the time during which components are exposed to the wave
- Solder bath specifications, including temperature and impurities

### 13.4 Reflow soldering

Key characteristics in reflow soldering are:

- Lead-free versus SnPb soldering; note that a lead-free reflow process usually leads to higher minimum peak temperatures (see [Figure 19](#)) than a SnPb process, thus reducing the process window
- Solder paste printing issues including smearing, release, and adjusting the process window for a mix of large and small components on one board
- Reflow temperature profile; this profile includes preheat, reflow (in which the board is heated to the peak temperature) and cooling down. It is imperative that the peak temperature is high enough for the solder to make reliable solder joints (a solder paste characteristic). In addition, the peak temperature must be low enough that the packages and/or boards are not damaged. The peak temperature of the package depends on package thickness and volume and is classified in accordance with [Table 6](#) and [7](#)

**Table 6. SnPb eutectic process (from J-STD-020D)**

Package thickness (mm)	Package reflow temperature (°C)	
	Volume (mm <sup>3</sup> )	
	< 350	≥ 350
< 2.5	235	220
≥ 2.5	220	220

**Table 7. Lead-free process (from J-STD-020D)**

Package thickness (mm)	Package reflow temperature (°C)		
	Volume (mm <sup>3</sup> )		
	< 350	350 to 2000	> 2000
< 1.6	260	260	260
1.6 to 2.5	260	250	245
> 2.5	250	245	245

Moisture sensitivity precautions, as indicated on the packing, must be respected at all times.

Studies have shown that small packages reach higher temperatures during reflow soldering, see [Figure 19](#).

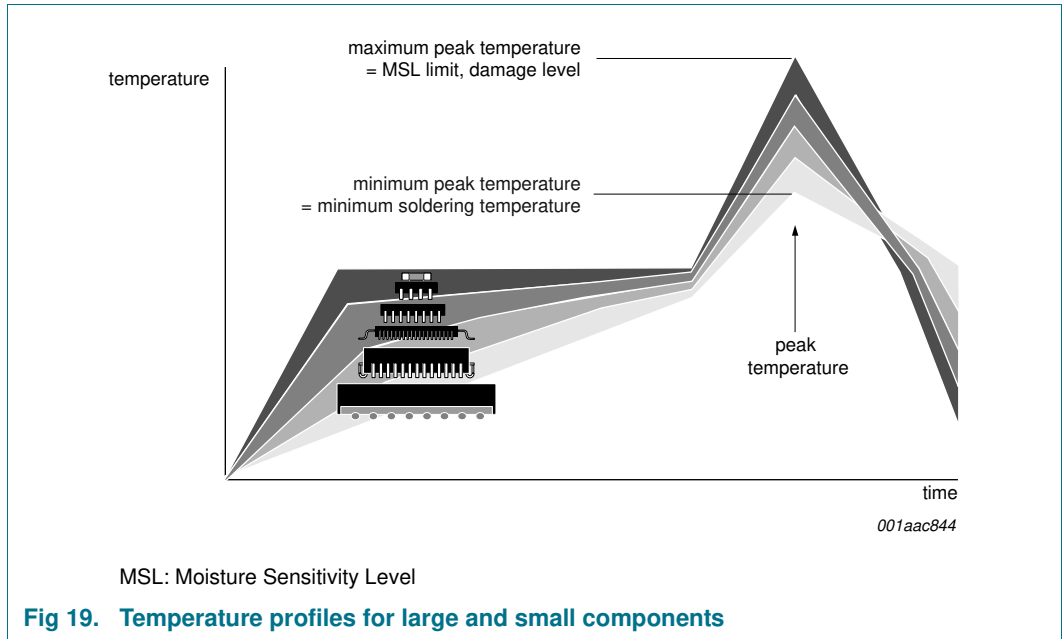

For further information on temperature profiles, refer to Application Note AN10365 “Surface mount reflow soldering description”.

## 14. Soldering: PCB footprints

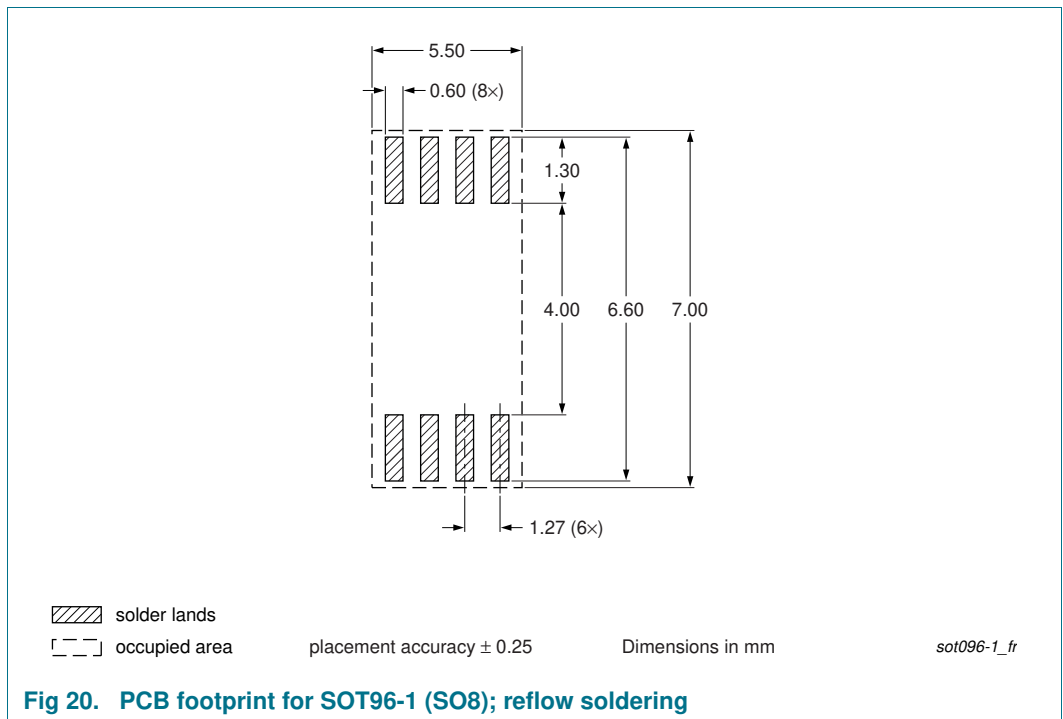

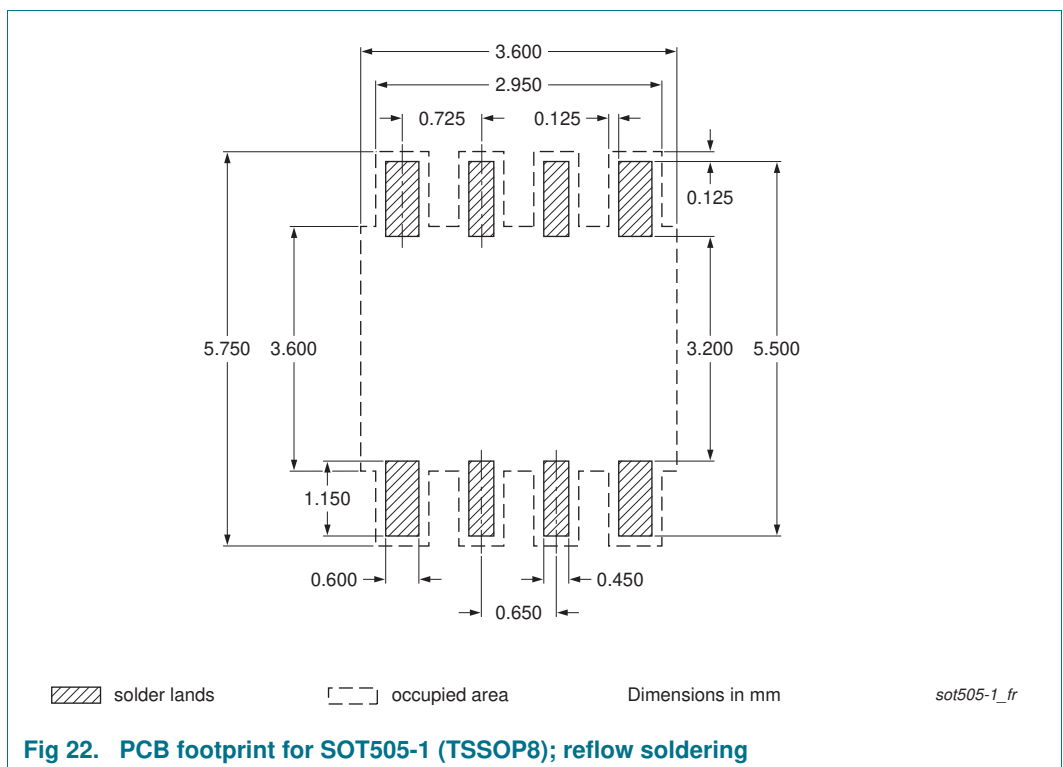
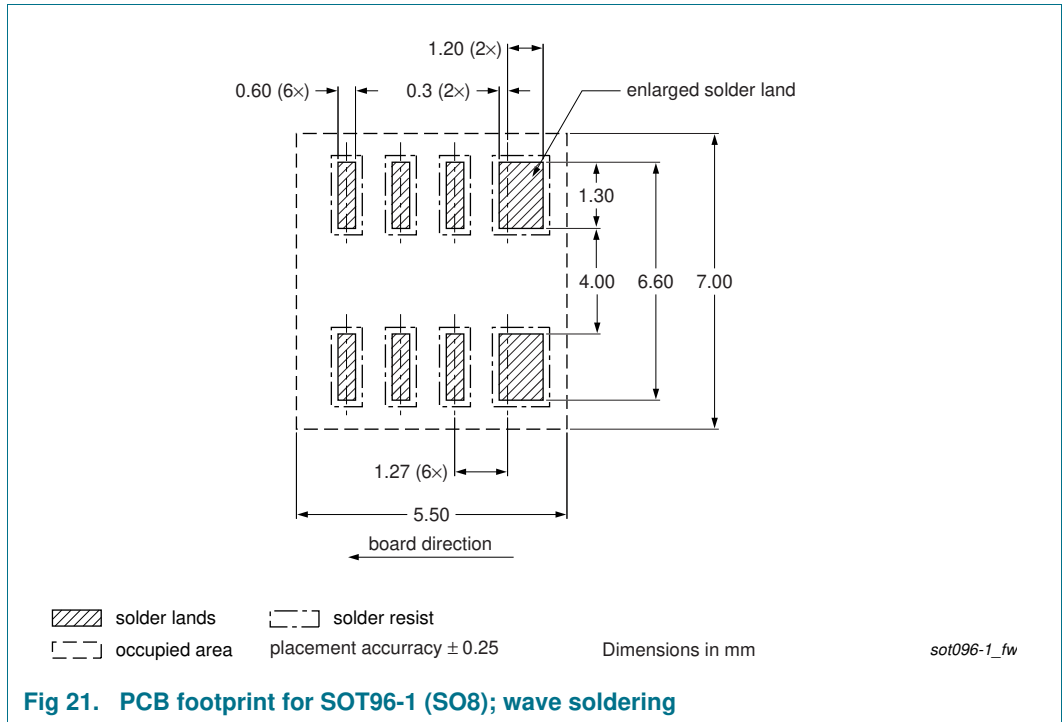

## 15. Abbreviations

**Table 8. Abbreviations**

<b>Acronym</b>	<b>Description</b>
ATCA	Advanced Telecommunications Computing Architecture
CDM	Charged-Device Model
cPCI	compact Peripheral Component Interconnect
ESD	ElectroStatic Discharge
HBM	Human Body Model
I <sup>2</sup> C-bus	Inter-Integrated Circuit bus
IC	Integrated Circuit
IPMB	Intelligent Platform Management Bus
PICMG	PCI Industrial Computer Manufacturers Group
PMBus	Power Management Bus
RAID	Redundant Array of Independent Discs
SMBus	System Management Bus

## 16. Revision history

Table 9. Revision history

Document ID	Release date	Data sheet status	Change notice	Supersedes
PCA9521 v.2	20130319	Product data sheet	-	PCA9521 v.1
Modifications:	<ul style="list-style-type: none"> <li>• Added <a href="#">Section 4.1 “Ordering options”</a></li> <li>• <a href="#">Table 5 “Characteristics”</a>, sub-section “Power supply”: <ul style="list-style-type: none"> <li>– I<sub>CC</sub> Typ value (operating) changed from “9 mA” to “6 mA”</li> <li>– I<sub>CC</sub> Typ value (standby) changed from “295 μA” to “670 μA”</li> <li>– I<sub>CC</sub> Max value (standby) changed from “350 μA” to “900 μA”</li> </ul> </li> <li>• <a href="#">Table 5 “Characteristics”</a>, sub-section “Buffer ports (SA1, SA2, SB1, SB2)”: <ul style="list-style-type: none"> <li>– V<sub>Sxx</sub> Min value changed from “-” to “1.8 V”</li> <li>– I<sub>IL</sub> Typ value changed from “-12 μA” to “-6 μA”</li> <li>– I<sub>IL</sub> Max value changed from “-30 μA” to “-20 μA”</li> <li>– V<sub>offset</sub> Condition changed from “V<sub>CC</sub> = 3.3 V” to “V<sub>CC</sub> = 5 V”</li> <li>– V<sub>offset</sub> (sub) Condition changed from “I<sub>OL</sub> = 4 mA” to “I<sub>OL</sub> = 5 mA”</li> <li>– V<sub>offset</sub> (Condition I<sub>OL</sub> = 5 mA): Typ value changed from “165 mV” to “230 mV”; Max value changed from “200 mV” to “300 mV”</li> <li>– V<sub>offset</sub> (Condition I<sub>OL</sub> = 500 μA): Typ value changed from “55 mV” to “90 mV”; Max value changed from “100 mV” to “125 mV”</li> <li>– V<sub>offset</sub> (Condition I<sub>OL</sub> = 1.2 mA): Typ value changed from “60 mV” to “90 mV”; Max value changed from “100 mV” to “125 mV”</li> </ul> </li> <li>• <a href="#">Table 5 “Characteristics”</a>, sub-section “Enable (EN)”: <ul style="list-style-type: none"> <li>– V<sub>en</sub> Min value changed from “1.2 V” to “1.3 V”</li> <li>– I<sub>I</sub> Min value changed from “1” to “0.7 μA”</li> </ul> </li> <li>• <a href="#">Table 5 “Characteristics”</a>, sub-section “Timing characteristics”: <ul style="list-style-type: none"> <li>– t<sub>d</sub> Typ value changed from “30 ns” to “45 ns”</li> <li>– t<sub>f</sub> Typ value changed from “15 ns” to “40 ns”</li> <li>– t<sub>d(en-act)</sub> Typ value changed from “1 μs” to “1.5 μs”</li> <li>– t<sub>d(dis-stb)</sub> Typ value changed from “1.1 μs” to “0.4 μs”</li> <li>– f<sub>oper(I2C)</sub> Max value changed from “400 kHz” to “1000 kHz”</li> <li>– deleted f<sub>oper(max)</sub> characteristic</li> </ul> </li> <li>• Added <a href="#">Section 14 “Soldering: PCB footprints”</a></li> </ul>			
PCA9521 v.1	20110822	Product data sheet	-	-

## 17. Legal information

### 17.1 Data sheet status

Document status <sup>[1][2]</sup>	Product status <sup>[3]</sup>	Definition
Objective [short] data sheet	Development	This document contains data from the objective specification for product development.
Preliminary [short] data sheet	Qualification	This document contains data from the preliminary specification.
Product [short] data sheet	Production	This document contains the product specification.

[1] Please consult the most recently issued document before initiating or completing a design.

[2] The term 'short data sheet' is explained in section "Definitions".

[3] The product status of device(s) described in this document may have changed since this document was published and may differ in case of multiple devices. The latest product status information is available on the Internet at URL <http://www.nxp.com>.

### 17.2 Definitions

**Draft** — The document is a draft version only. The content is still under internal review and subject to formal approval, which may result in modifications or additions. NXP Semiconductors does not give any representations or warranties as to the accuracy or completeness of information included herein and shall have no liability for the consequences of use of such information.

**Short data sheet** — A short data sheet is an extract from a full data sheet with the same product type number(s) and title. A short data sheet is intended for quick reference only and should not be relied upon to contain detailed and full information. For detailed and full information see the relevant full data sheet, which is available on request via the local NXP Semiconductors sales office. In case of any inconsistency or conflict with the short data sheet, the full data sheet shall prevail.

**Product specification** — The information and data provided in a Product data sheet shall define the specification of the product as agreed between NXP Semiconductors and its customer, unless NXP Semiconductors and customer have explicitly agreed otherwise in writing. In no event however, shall an agreement be valid in which the NXP Semiconductors product is deemed to offer functions and qualities beyond those described in the Product data sheet.

### 17.3 Disclaimers

**Limited warranty and liability** — Information in this document is believed to be accurate and reliable. However, NXP Semiconductors does not give any representations or warranties, expressed or implied, as to the accuracy or completeness of such information and shall have no liability for the consequences of use of such information. NXP Semiconductors takes no responsibility for the content in this document if provided by an information source outside of NXP Semiconductors.

In no event shall NXP Semiconductors be liable for any indirect, incidental, punitive, special or consequential damages (including - without limitation - lost profits, lost savings, business interruption, costs related to the removal or replacement of any products or rework charges) whether or not such damages are based on tort (including negligence), warranty, breach of contract or any other legal theory.

Notwithstanding any damages that customer might incur for any reason whatsoever, NXP Semiconductors' aggregate and cumulative liability towards customer for the products described herein shall be limited in accordance with the *Terms and conditions of commercial sale* of NXP Semiconductors.

**Right to make changes** — NXP Semiconductors reserves the right to make changes to information published in this document, including without limitation specifications and product descriptions, at any time and without notice. This document supersedes and replaces all information supplied prior to the publication hereof.

**Suitability for use** — NXP Semiconductors products are not designed, authorized or warranted to be suitable for use in life support, life-critical or safety-critical systems or equipment, nor in applications where failure or malfunction of an NXP Semiconductors product can reasonably be expected to result in personal injury, death or severe property or environmental damage. NXP Semiconductors and its suppliers accept no liability for inclusion and/or use of NXP Semiconductors products in such equipment or applications and therefore such inclusion and/or use is at the customer's own risk.

**Applications** — Applications that are described herein for any of these products are for illustrative purposes only. NXP Semiconductors makes no representation or warranty that such applications will be suitable for the specified use without further testing or modification.

Customers are responsible for the design and operation of their applications and products using NXP Semiconductors products, and NXP Semiconductors accepts no liability for any assistance with applications or customer product design. It is customer's sole responsibility to determine whether the NXP Semiconductors product is suitable and fit for the customer's applications and products planned, as well as for the planned application and use of customer's third party customer(s). Customers should provide appropriate design and operating safeguards to minimize the risks associated with their applications and products.

NXP Semiconductors does not accept any liability related to any default, damage, costs or problem which is based on any weakness or default in the customer's applications or products, or the application or use by customer's third party customer(s). Customer is responsible for doing all necessary testing for the customer's applications and products using NXP Semiconductors products in order to avoid a default of the applications and the products or of the application or use by customer's third party customer(s). NXP does not accept any liability in this respect.

**Limiting values** — Stress above one or more limiting values (as defined in the Absolute Maximum Ratings System of IEC 60134) will cause permanent damage to the device. Limiting values are stress ratings only and (proper) operation of the device at these or any other conditions above those given in the Recommended operating conditions section (if present) or the Characteristics sections of this document is not warranted. Constant or repeated exposure to limiting values will permanently and irreversibly affect the quality and reliability of the device.

**Terms and conditions of commercial sale** — NXP Semiconductors products are sold subject to the general terms and conditions of commercial sale, as published at <http://www.nxp.com/profile/terms>, unless otherwise agreed in a valid written individual agreement. In case an individual agreement is concluded only the terms and conditions of the respective agreement shall apply. NXP Semiconductors hereby expressly objects to applying the customer's general terms and conditions with regard to the purchase of NXP Semiconductors products by customer.

**No offer to sell or license** — Nothing in this document may be interpreted or construed as an offer to sell products that is open for acceptance or the grant, conveyance or implication of any license under any copyrights, patents or other industrial or intellectual property rights.

**Export control** — This document as well as the item(s) described herein may be subject to export control regulations. Export might require a prior authorization from competent authorities.

**Non-automotive qualified products** — Unless this data sheet expressly states that this specific NXP Semiconductors product is automotive qualified, the product is not suitable for automotive use. It is neither qualified nor tested in accordance with automotive testing or application requirements. NXP Semiconductors accepts no liability for inclusion and/or use of non-automotive qualified products in automotive equipment or applications.

In the event that customer uses the product for design-in and use in automotive applications to automotive specifications and standards, customer (a) shall use the product without NXP Semiconductors' warranty of the product for such automotive applications, use and specifications, and (b) whenever customer uses the product for automotive applications beyond NXP Semiconductors' specifications such use shall be solely at customer's

own risk, and (c) customer fully indemnifies NXP Semiconductors for any liability, damages or failed product claims resulting from customer design and use of the product for automotive applications beyond NXP Semiconductors' standard warranty and NXP Semiconductors' product specifications.

**Translations** — A non-English (translated) version of a document is for reference only. The English version shall prevail in case of any discrepancy between the translated and English versions.

## 17.4 Trademarks

Notice: All referenced brands, product names, service names and trademarks are the property of their respective owners.

**I<sup>2</sup>C-bus** — logo is a trademark of NXP B.V.

## 18. Contact information

For more information, please visit: <http://www.nxp.com>

For sales office addresses, please send an email to: [salesaddresses@nxp.com](mailto:salesaddresses@nxp.com)

## 19. Contents

<b>1</b>	<b>General description</b> .....	<b>1</b>
<b>2</b>	<b>Features and benefits</b> .....	<b>1</b>
<b>3</b>	<b>Applications</b> .....	<b>2</b>
<b>4</b>	<b>Ordering information</b> .....	<b>2</b>
4.1	Ordering options .....	2
<b>5</b>	<b>Block diagram</b> .....	<b>3</b>
<b>6</b>	<b>Pinning information</b> .....	<b>3</b>
6.1	Pinning .....	3
6.2	Pin description .....	3
<b>7</b>	<b>Functional description</b> .....	<b>4</b>
7.1	V <sub>CC</sub> , GND — supply pins .....	4
7.2	SA1, SA2, SB1, SB2 — buffer inputs/outputs .	4
7.3	EN — enable; activate buffer operations .....	4
<b>8</b>	<b>Limiting values</b> .....	<b>5</b>
<b>9</b>	<b>Characteristics</b> .....	<b>5</b>
<b>10</b>	<b>Application information</b> .....	<b>8</b>
10.1	Design considerations .....	8
10.2	Input to output offset voltage calculation .....	12
<b>11</b>	<b>Package outline</b> .....	<b>13</b>
<b>12</b>	<b>Handling information</b> .....	<b>15</b>
<b>13</b>	<b>Soldering of SMD packages</b> .....	<b>15</b>
13.1	Introduction to soldering .....	15
13.2	Wave and reflow soldering .....	15
13.3	Wave soldering .....	16
13.4	Reflow soldering .....	16
<b>14</b>	<b>Soldering: PCB footprints</b> .....	<b>17</b>
<b>15</b>	<b>Abbreviations</b> .....	<b>19</b>
<b>16</b>	<b>Revision history</b> .....	<b>20</b>
<b>17</b>	<b>Legal information</b> .....	<b>21</b>
17.1	Data sheet status .....	21
17.2	Definitions .....	21
17.3	Disclaimers .....	21
17.4	Trademarks .....	22
<b>18</b>	<b>Contact information</b> .....	<b>22</b>
<b>19</b>	<b>Contents</b> .....	<b>23</b>

Please be aware that important notices concerning this document and the product(s) described herein, have been included in section 'Legal information'.

© NXP B.V. 2013.

All rights reserved.

For more information, please visit: <http://www.nxp.com>

For sales office addresses, please send an email to: [salesaddresses@nxp.com](mailto:salesaddresses@nxp.com)

Date of release: 19 March 2013

Document identifier: PCA9521