



Chipsmall Limited consists of a professional team with an average of over 10 year of expertise in the distribution of electronic components. Based in Hongkong, we have already established firm and mutual-benefit business relationships with customers from,Europe,America and south Asia,supplying obsolete and hard-to-find components to meet their specific needs.

With the principle of “Quality Parts,Customers Priority,Honest Operation,and Considerate Service”,our business mainly focus on the distribution of electronic components. Line cards we deal with include Microchip,ALPS,ROHM,Xilinx,Pulse,ON,Everlight and Freescale. Main products comprise IC,Modules,Potentiometer,IC Socket,Relay,Connector.Our parts cover such applications as commercial,industrial, and automotives areas.

We are looking forward to setting up business relationship with you and hope to provide you with the best service and solution. Let us make a better world for our industry!



Contact us

Tel: +86-755-8981 8866 Fax: +86-755-8427 6832

Email & Skype: info@chipsmall.com Web: www.chipsmall.com

Address: A1208, Overseas Decoration Building, #122 Zhenhua RD., Futian, Shenzhen, China





PCA9539A

Low-voltage 16-bit I²C-bus I/O port with interrupt and reset

Rev. 2 — 12 August 2013

Product data sheet

1. General description

The PCA9539A is a low-voltage 16-bit General Purpose Input/Output (GPIO) expander with interrupt and reset for I²C-bus/SMBus applications. NXP I/O expanders provide a simple solution when additional I/Os are needed while keeping interconnections to a minimum, for example, in ACPI power switches, sensors, push buttons, LEDs, fan control, etc.

In addition to providing a flexible set of GPIOs, the wide V_{DD} range of 1.65 V to 5.5 V allows the PCA9539A to interface with next-generation microprocessors and microcontrollers where supply levels are dropping down to conserve power.

The PCA9539A contains the PCA9539 register set of four pairs of 8-bit Configuration, Input, Output, and Polarity Inversion registers.

The PCA9539A is a pin-to-pin replacement to the PCA9539, and other industry-standard part numbers. A more fully featured part, PCAL9539A is also available with Agile I/O features. See the respective data sheet for more details.

The PCA9539A open-drain interrupt (\overline{INT}) output is activated when any input state differs from its corresponding Input Port register state and is used to indicate to the system master that an input state has changed.

\overline{INT} can be connected to the interrupt input of a microcontroller. By sending an interrupt signal on this line, the remote I/O can inform the microcontroller if there is incoming data on its ports without having to communicate via the I²C-bus. Thus, the PCA9539A can remain a simple slave device.

The device outputs have 25 mA sink capabilities for directly driving LEDs while consuming low device current.

The power-on reset sets the registers to their default values and initializes the device state machine. In the PCA9539A, the \overline{RESET} pin causes the same reset/default I/O input configuration to occur without de-powering the device, holding the registers and I²C-bus state machine in their default state until the \overline{RESET} input is once again HIGH. This input requires a pull-up to V_{DD} .

Two hardware pins (A0, A1) select the fixed I²C-bus address and allow up to four devices to share the same I²C-bus/SMBus.



2. Features and benefits

- I²C-bus to parallel port expander
- Pin and function compatible with PCA9539
- Operating power supply voltage range of 1.65 V to 5.5 V
- Low standby current consumption:
 - ◆ 1.5 μ A (typical at 5 V V_{DD})
 - ◆ 1.0 μ A (typical at 3.3 V V_{DD})
- Schmitt-trigger action allows slow input transition and better switching noise immunity at the SCL and SDA inputs
 - ◆ $V_{hys} = 0.10 \times V_{DD}$ (typical)
- 5 V tolerant I/Os
- Active LOW reset input (\overline{RESET})
- Open-drain active LOW interrupt output (\overline{INT})
- 400 kHz Fast-mode I²C-bus
- Internal power-on reset
- Power-up with all channels configured as inputs
- No glitch on power-up
- Latched outputs with 25 mA drive maximum capability for directly driving LEDs
- Latch-up performance exceeds 100 mA per JESD78, Class II
- ESD protection exceeds JESD22
 - ◆ 2000 V Human Body Model (A114-A)
 - ◆ 1000 V Charged-Device Model (C101)
- Packages offered: TSSOP24, HWQFN24

3. Ordering information

Table 1. Ordering information

Type number	Topside marking	Package		Version
		Name	Description	
PCA9539APW	PCA9539A	TSSOP24	plastic thin shrink small outline package; 24 leads; body width 4.4 mm	SOT355-1
PCA9539AHF	539A	HWQFN24	plastic thermal enhanced very very thin quad flat package; no leads; 24 terminals; body 4 × 4 × 0.75 mm	SOT994-1

3.1 Ordering options

Table 2. Ordering options

Type number	Orderable part number	Package	Packing method	Minimum order quantity	Temperature range
PCA9539APW	PCA9539APW,118	TSSOP24	Reel 13" Q1/T1 *Standard mark SMD	2500	-40 °C to +85 °C
PCA9539AHF	PCA9539AHF,128	HWQFN24	Reel 13" Q2/T3 *Standard mark SMD	6000	-40 °C to +85 °C

4. Block diagram

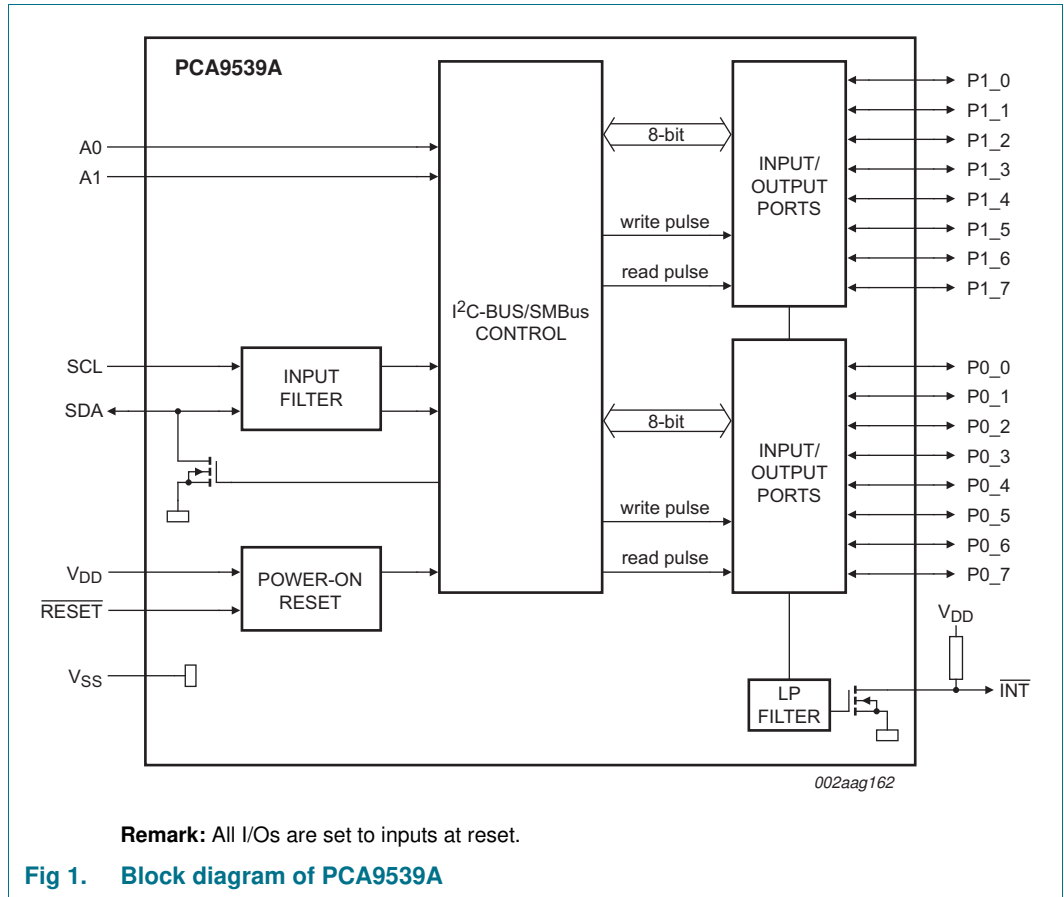

5. Pinning information

5.1 Pinning

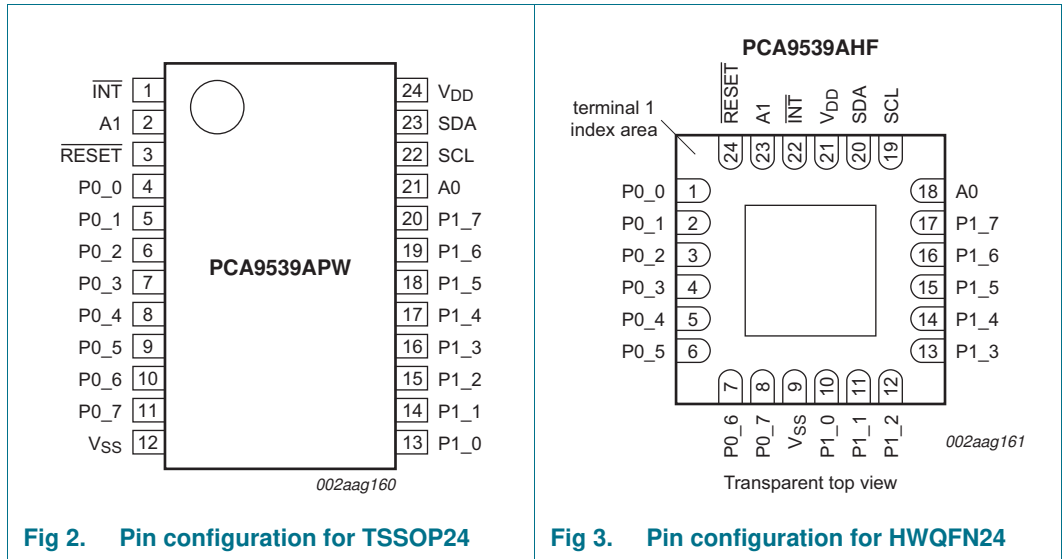

Fig 2. Pin configuration for TSSOP24

Fig 3. Pin configuration for HWQFN24

5.2 Pin description

Table 3. Pin description

Symbol	Pin		Type	Description
	TSSOP24	HWQFN24		
INT	1	22	O	Interrupt output. Connect to V _{DD} through a pull-up resistor.
A1	2	23	I	Address input 1. Connect directly to V _{DD} or V _{SS} .
RESET	3	24	I	Active LOW reset input. Connect to V _{DD} through a pull-up resistor if no active connection is used.
P0_0 ^[2]	4	1	I/O	Port 0 input/output 0.
P0_1 ^[2]	5	2	I/O	Port 0 input/output 1.
P0_2 ^[2]	6	3	I/O	Port 0 input/output 2.
P0_3 ^[2]	7	4	I/O	Port 0 input/output 3.
P0_4 ^[2]	8	5	I/O	Port 0 input/output 4.
P0_5 ^[2]	9	6	I/O	Port 0 input/output 5.
P0_6 ^[2]	10	7	I/O	Port 0 input/output 6.
P0_7 ^[2]	11	8	I/O	Port 0 input/output 7.
V _{SS}	12	9 ^[1]	power	Ground.
P1_0 ^[3]	13	10	I/O	Port 1 input/output 0.
P1_1 ^[3]	14	11	I/O	Port 1 input/output 1.
P1_2 ^[3]	15	12	I/O	Port 1 input/output 2.
P1_3 ^[3]	16	13	I/O	Port 1 input/output 3.
P1_4 ^[3]	17	14	I/O	Port 1 input/output 4.
P1_5 ^[3]	18	15	I/O	Port 1 input/output 5.

Table 3. Pin description ...continued

Symbol	Pin		Type	Description
	TSSOP24	HWQFN24		
P1_6 ^[3]	19	16	I/O	Port 1 input/output 6.
P1_7 ^[3]	20	17	I/O	Port 1 input/output 7.
A0	21	18	I	Address input 0. Connect directly to V _{DD} or V _{SS} .
SCL	22	19	I	Serial clock bus. Connect to V _{DD} through a pull-up resistor.
SDA	23	20	I/O	Serial data bus. Connect to V _{DD} through a pull-up resistor.
V _{DD}	24	21	power	Supply voltage.

- [1] HWQFN24 package die supply ground is connected to both V_{SS} pin and exposed center pad. V_{SS} pin must be connected to supply ground for proper device operation. For enhanced thermal, electrical, and board level performance, the exposed pad needs to be soldered to the board using a corresponding thermal pad on the board and for proper heat conduction through the board, thermal vias need to be incorporated in the PCB in the thermal pad region.
- [2] Pins P0_0 to P0_7 correspond to bits P0.0 to P0.7. At power-up, all I/O are configured as high-impedance inputs.
- [3] Pins P1_0 to P1_7 correspond to bits P1.0 to P1.7. At power-up, all I/O are configured as high-impedance inputs.

6. Functional description

Refer to [Figure 1 “Block diagram of PCA9539A”](#).

6.1 Device address

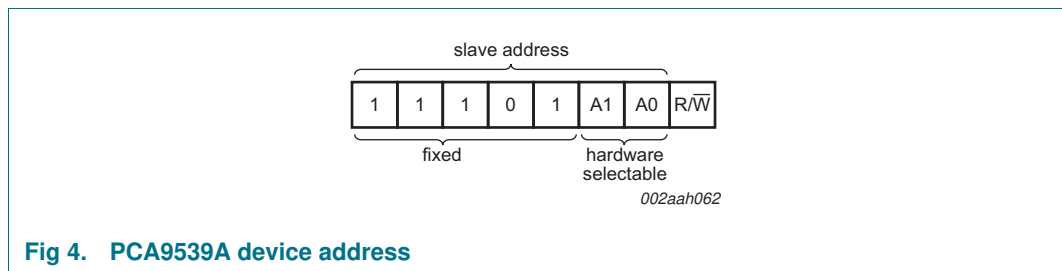

Fig 4. PCA9539A device address

A1 and A0 are the hardware address package pins and are held to either HIGH (logic 1) or LOW (logic 0) to assign one of the four possible slave addresses. The last bit of the slave address (R/W) defines the operation (read or write) to be performed. A HIGH (logic 1) selects a read operation, while a LOW (logic 0) selects a write operation.

6.2 Registers

6.2.1 Pointer register and command byte

Following the successful acknowledgement of the address byte, the bus master sends a command byte, which is stored in the Pointer register in the PCA9539A. The lower four bits of this data byte state the operation (read or write) and the internal registers (Input, Output, Polarity Inversion, or Configuration) that will be affected. This register is write only.

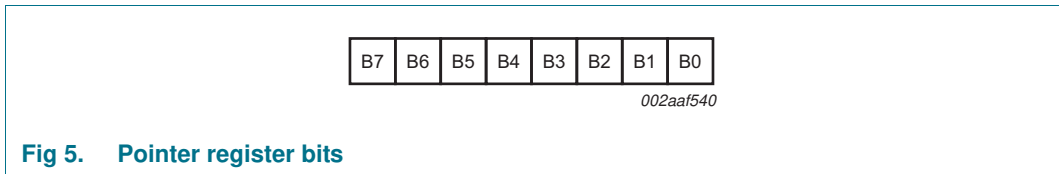

Fig 5. Pointer register bits

Table 4. Command byte

Pointer register bits								Command byte (hexadecimal)	Register	Protocol	Power-up default
B7	B6	B5	B4	B3	B2	B1	B0				
0	0	0	0	0	0	0	0	00h	Input port 0	read byte	xxxx xxxx ^[1]
0	0	0	0	0	0	0	1	01h	Input port 1	read byte	xxxx xxxx
0	0	0	0	0	0	1	0	02h	Output port 0	read/write byte	1111 1111
0	0	0	0	0	0	1	1	03h	Output port 1	read/write byte	1111 1111
0	0	0	0	0	1	0	0	04h	Polarity Inversion port 0	read/write byte	0000 0000
0	0	0	0	0	1	0	1	05h	Polarity Inversion port 1	read/write byte	0000 0000
0	0	0	0	0	1	1	0	06h	Configuration port 0	read/write byte	1111 1111
0	0	0	0	0	1	1	1	07h	Configuration port 1	read/write byte	1111 1111

[1] Undefined.

6.2.2 Input port register pair (00h, 01h)

The Input port registers (registers 0 and 1) reflect the incoming logic levels of the pins, regardless of whether the pin is defined as an input or an output by the Configuration register. The Input port registers are read only; writes to these registers have no effect. The default value 'X' is determined by the externally applied logic level. An Input port register read operation is performed as described in [Section 7.2 "Reading the port registers"](#).

Table 5. Input port 0 register (address 00h)

Bit	7	6	5	4	3	2	1	0
Symbol	I0.7	I0.6	I0.5	I0.4	I0.3	I0.2	I0.1	I0.0
Default	X	X	X	X	X	X	X	X

Table 6. Input port 1 register (address 01h)

Bit	7	6	5	4	3	2	1	0
Symbol	I1.7	I1.6	I1.5	I1.4	I1.3	I1.2	I1.1	I1.0
Default	X	X	X	X	X	X	X	X

6.2.3 Output port register pair (02h, 03h)

The Output port registers (registers 2 and 3) show the outgoing logic levels of the pins defined as outputs by the Configuration register. Bit values in these registers have no effect on pins defined as inputs. In turn, reads from these registers reflect the value that was written to these registers, **not** the actual pin value. A register pair write is described in [Section 7.1](#) and a register pair read is described in [Section 7.2](#).

Table 7. Output port 0 register (address 02h)

Bit	7	6	5	4	3	2	1	0
Symbol	O0.7	O0.6	O0.5	O0.4	O0.3	O0.2	O0.1	O0.0
Default	1	1	1	1	1	1	1	1

Table 8. Output port 1 register (address 03h)

Bit	7	6	5	4	3	2	1	0
Symbol	O1.7	O1.6	O1.5	O1.4	O1.3	O1.2	O1.1	O1.0
Default	1	1	1	1	1	1	1	1

6.2.4 Polarity inversion register pair (04h, 05h)

The Polarity inversion registers (registers 4 and 5) allow polarity inversion of pins defined as inputs by the Configuration register. If a bit in these registers is set (written with '1'), the corresponding port pin's polarity is inverted in the Input register. If a bit in this register is cleared (written with a '0'), the corresponding port pin's polarity is retained. A register pair write is described in [Section 7.1](#) and a register pair read is described in [Section 7.2](#).

Table 9. Polarity inversion port 0 register (address 04h)

Bit	7	6	5	4	3	2	1	0
Symbol	N0.7	N0.6	N0.5	N0.4	N0.3	N0.2	N0.1	N0.0
Default	0	0	0	0	0	0	0	0

Table 10. Polarity inversion port 1 register (address 05h)

Bit	7	6	5	4	3	2	1	0
Symbol	N1.7	N1.6	N1.5	N1.4	N1.3	N1.2	N1.1	N1.0
Default	0	0	0	0	0	0	0	0

6.2.5 Configuration register pair (06h, 07h)

The Configuration registers (registers 6 and 7) configure the direction of the I/O pins. If a bit in these registers is set to 1, the corresponding port pin is enabled as a high-impedance input. If a bit in these registers is cleared to 0, the corresponding port pin is enabled as an output. A register pair write is described in [Section 7.1](#) and a register pair read is described in [Section 7.2](#).

Table 11. Configuration port 0 register (address 06h)

Bit	7	6	5	4	3	2	1	0
Symbol	C0.7	C0.6	C0.5	C0.4	C0.3	C0.2	C0.1	C0.0
Default	1	1	1	1	1	1	1	1

Table 12. Configuration port 1 register (address 07h)

Bit	7	6	5	4	3	2	1	0
Symbol	C1.7	C1.6	C1.5	C1.4	C1.3	C1.2	C1.1	C1.0
Default	1	1	1	1	1	1	1	1

6.3 I/O port

When an I/O is configured as an input, FETs Q1 and Q2 are off, which creates a high-impedance input. The input voltage may be raised above V_{DD} to a maximum of 5.5 V.

If the I/O is configured as an output, Q1 or Q2 is enabled, depending on the state of the Output port register. In this case, there are low-impedance paths between the I/O pin and either V_{DD} or V_{SS}. The external voltage applied to this I/O pin should not exceed the recommended levels for proper operation.

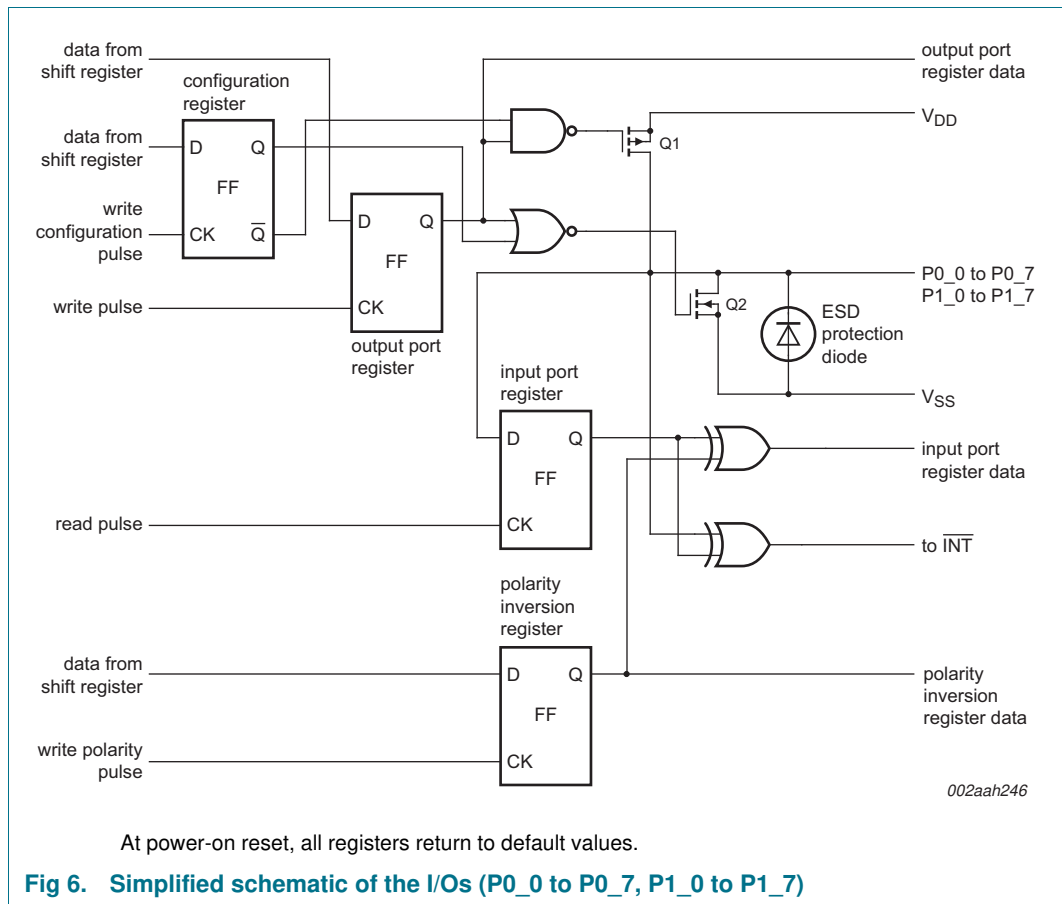

6.4 Power-on reset

When power (from 0 V) is applied to V_{DD}, an internal power-on reset holds the PCA9539A in a reset condition until V_{DD} has reached V_{POR}. At that time, the reset condition is released and the PCA9539A registers and I²C-bus/SMBus state machine initializes to their default states. After that, V_{DD} must be lowered to below V_{PORF} and back up to the operating voltage for a power-reset cycle. See [Section 8.2 “Power-on reset requirements”](#).

6.5 $\overline{\text{RESET}}$ input

The $\overline{\text{RESET}}$ input can be asserted to initialize the system while keeping the V_{DD} at its operating level. A reset can be accomplished by holding the $\overline{\text{RESET}}$ pin LOW for a minimum of $t_{\text{w}(\text{rst})}$. The PCA9539A registers and I²C-bus/SMBus state machine are changed to their default state once $\overline{\text{RESET}}$ is LOW (0). When $\overline{\text{RESET}}$ is HIGH (1), the I/O levels at the ports can be changed externally or through the master. This input requires a pull-up resistor to V_{DD} if no active connection is used.

6.6 Interrupt output

An interrupt is generated by any rising or falling edge of the port inputs in the Input mode. After time $t_{\text{V}(\text{INT})}$, the signal $\overline{\text{INT}}$ is valid. The interrupt is reset when data on the port changes back to the original value or when data is read from the port that generated the interrupt (see [Figure 10](#)). Resetting occurs in the Read mode at the acknowledge (ACK) or not acknowledge (NACK) bit after the rising edge of the SCL signal. Interrupts that occur during the ACK or NACK clock pulse can be lost (or be very short) due to the resetting of the interrupt during this pulse. Any change of the I/Os after resetting is detected and is transmitted as $\overline{\text{INT}}$.

A pin configured as an output cannot cause an interrupt. Changing an I/O from an output to an input may cause a false interrupt to occur, if the state of the pin does not match the contents of the Input Port register.

The $\overline{\text{INT}}$ output has an open-drain structure and requires pull-up resistor to V_{DD} .

7. Bus transactions

The PCA9539A is an I²C-bus slave device. Data is exchanged between the master and PCA9539A through write and read commands using I²C-bus. The two communication lines are a serial data line (SDA) and a serial clock line (SCL). Both lines must be connected to a positive supply via a pull-up resistor when connected to the output stages of a device. Data transfer may be initiated only when the bus is not busy.

7.1 Writing to the port registers

Data is transmitted to the PCA9539A by sending the device address and setting the least significant bit to a logic 0 (see [Figure 4 “PCA9539A device address”](#)). The command byte is sent after the address and determines which register will receive the data following the command byte.

Eight registers within the PCA9539A are configured to operate as four register pairs. The four pairs are input port, output port, polarity inversion, and configuration registers. After sending data to one register, the next data byte is sent to the other register in the pair (see [Figure 7](#) and [Figure 8](#)). For example, if the first byte is sent to Output Port 1 (register 3), the next byte is stored in Output Port 0 (register 2).

There is no limitation on the number of data bytes sent in one write transmission. In this way, the host can continuously update a register pair independently of the other registers, or the host can simply update a single register.

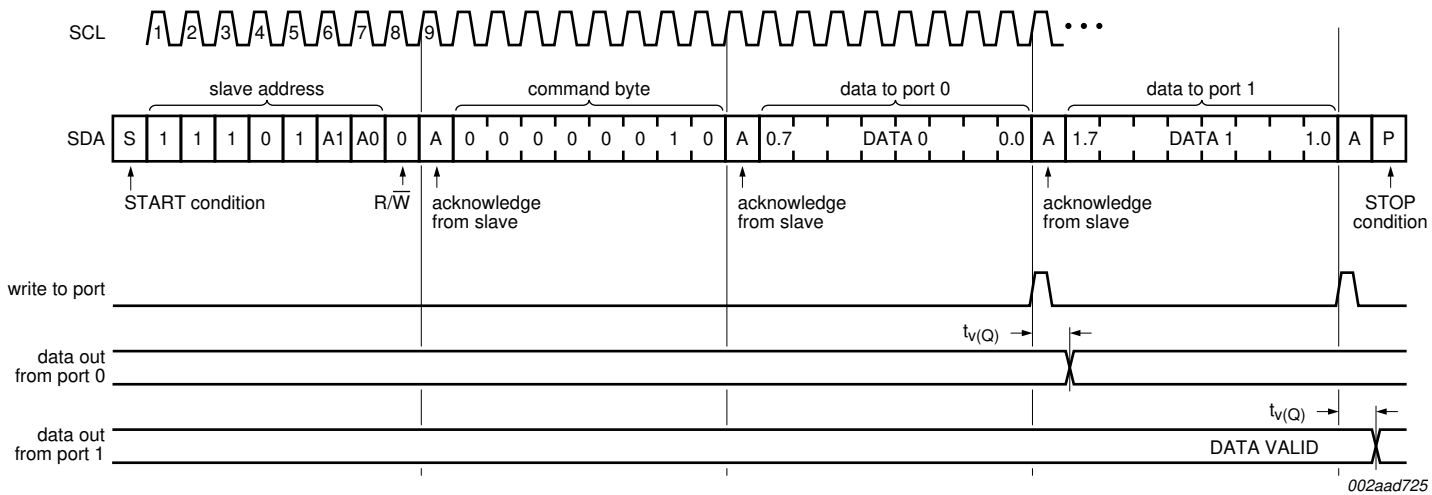

002aad725

Fig 7. Write to output port registers

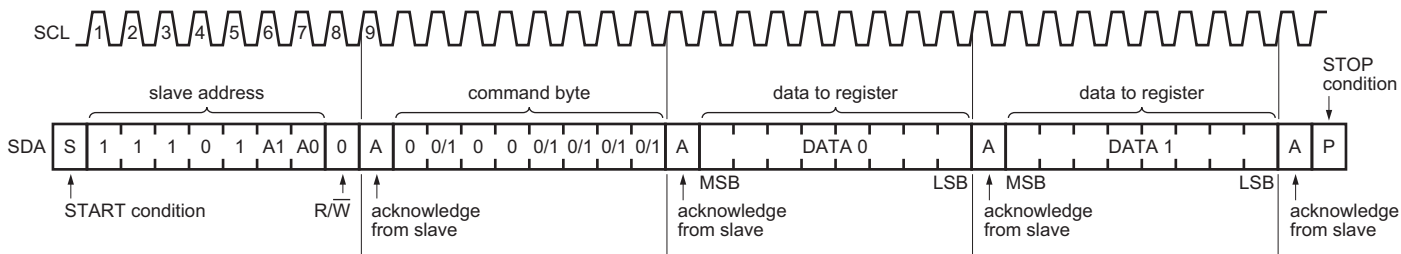

002aah063

Fig 8. Write to Control registers

7.2 Reading the port registers

In order to read data from the PCA9539A, the bus master must first send the PCA9539A address with the least significant bit set to a logic 0 (see [Figure 4 "PCA9539A device address"](#)). The command byte is sent after the address and determines which register will be accessed. After a restart, the device address is sent again, but this time the least significant bit is set to a logic 1. Data from the register defined by the command byte is sent by the PCA9539A (see [Figure 9](#), [Figure 10](#) and [Figure 11](#)). Data is clocked into the register on the falling edge of the acknowledge clock pulse. After the first byte is read, additional bytes may be read but the data now reflects the information in the other register in the pair. For example, if Input Port 1 is read, the next byte read is Input Port 0. There is no limit on the number of data bytes received in one read transmission, but on the final byte received the bus master must not acknowledge the data.

After a subsequent restart, the command byte contains the value of the next register to be read in the pair. For example, if Input Port 1 was read last before the restart, the register that is read after the restart is the Input Port 0.

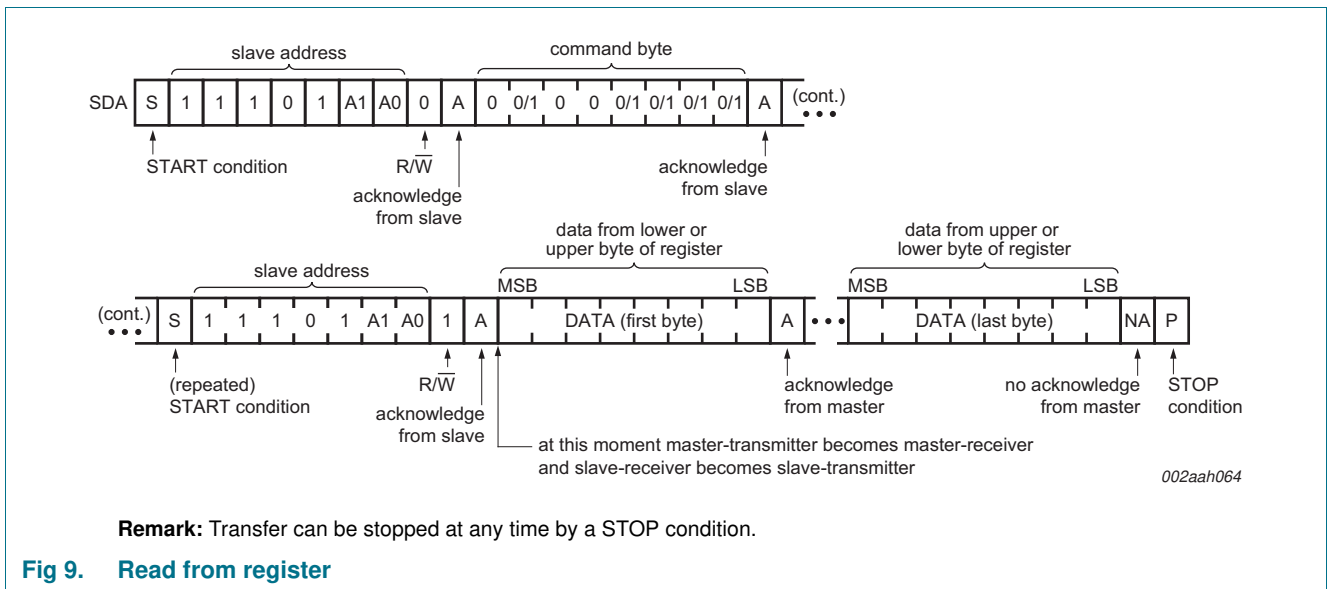

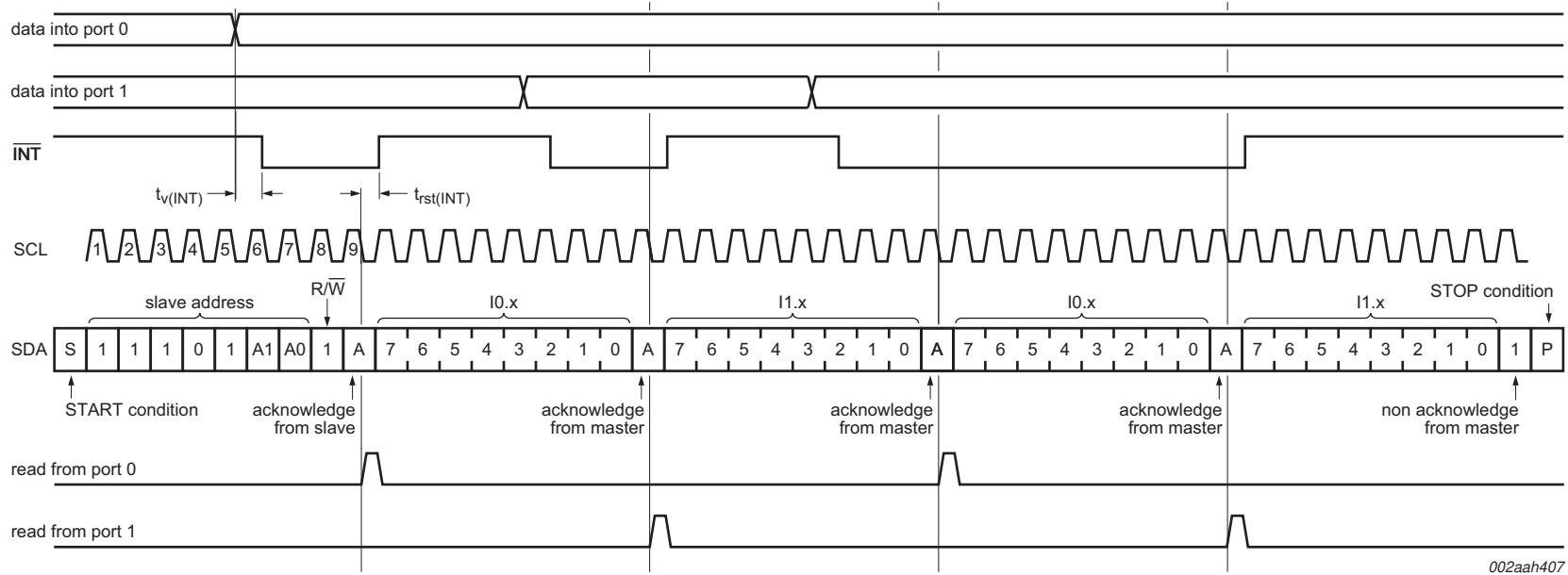

002aah407

Remark: Transfer of data can be stopped at any moment by a STOP condition. When this occurs, data present at the latest acknowledge phase is valid (output mode). It is assumed that the command byte has previously been set to '00' (read input port register).

This figure eliminates the command byte transfer and a restart between the initial slave address call and the actual data transfer from P port (see [Figure 9](#)).

Fig 10. Read input port register, scenario 1

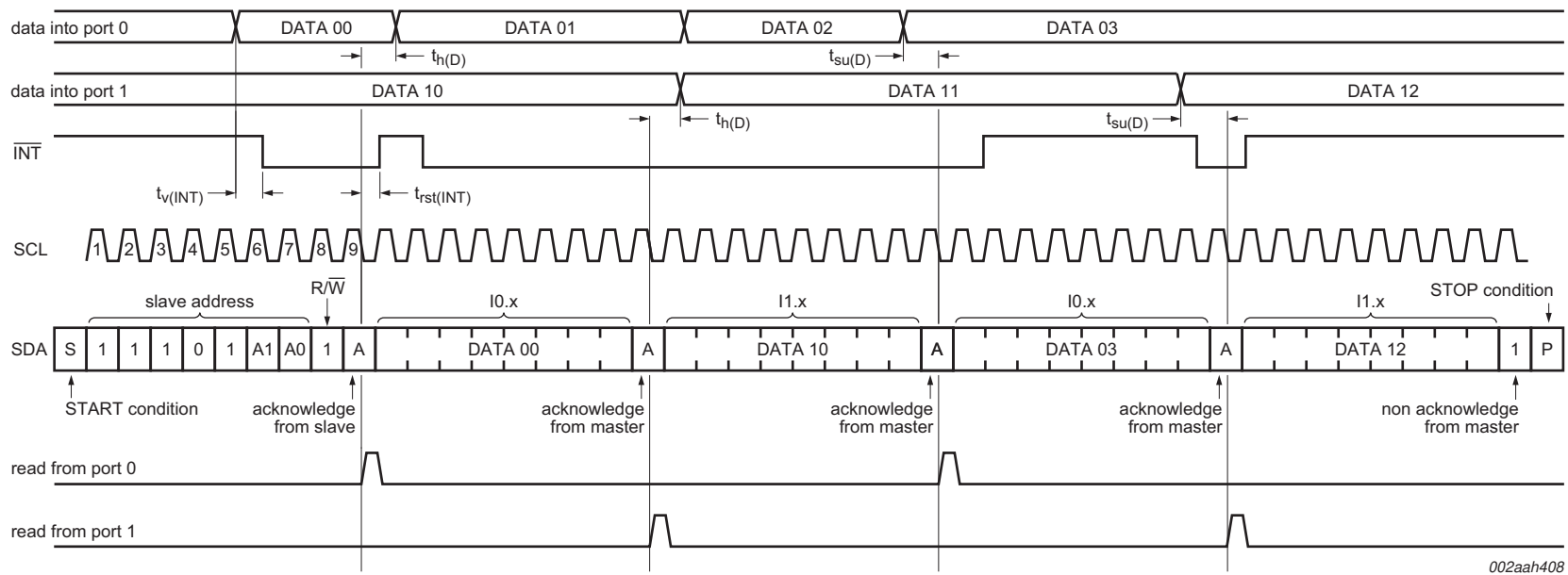

002aah408

Remark: Transfer of data can be stopped at any moment by a STOP condition. When this occurs, data present at the latest acknowledge phase is valid (output mode). It is assumed that the command byte has previously been set to '00' (read input port register).

This figure eliminates the command byte transfer and a restart between the initial slave address call and the actual data transfer from P port (see [Figure 9](#)).

Fig 11. Read input port register, scenario 2

8. Application design-in information

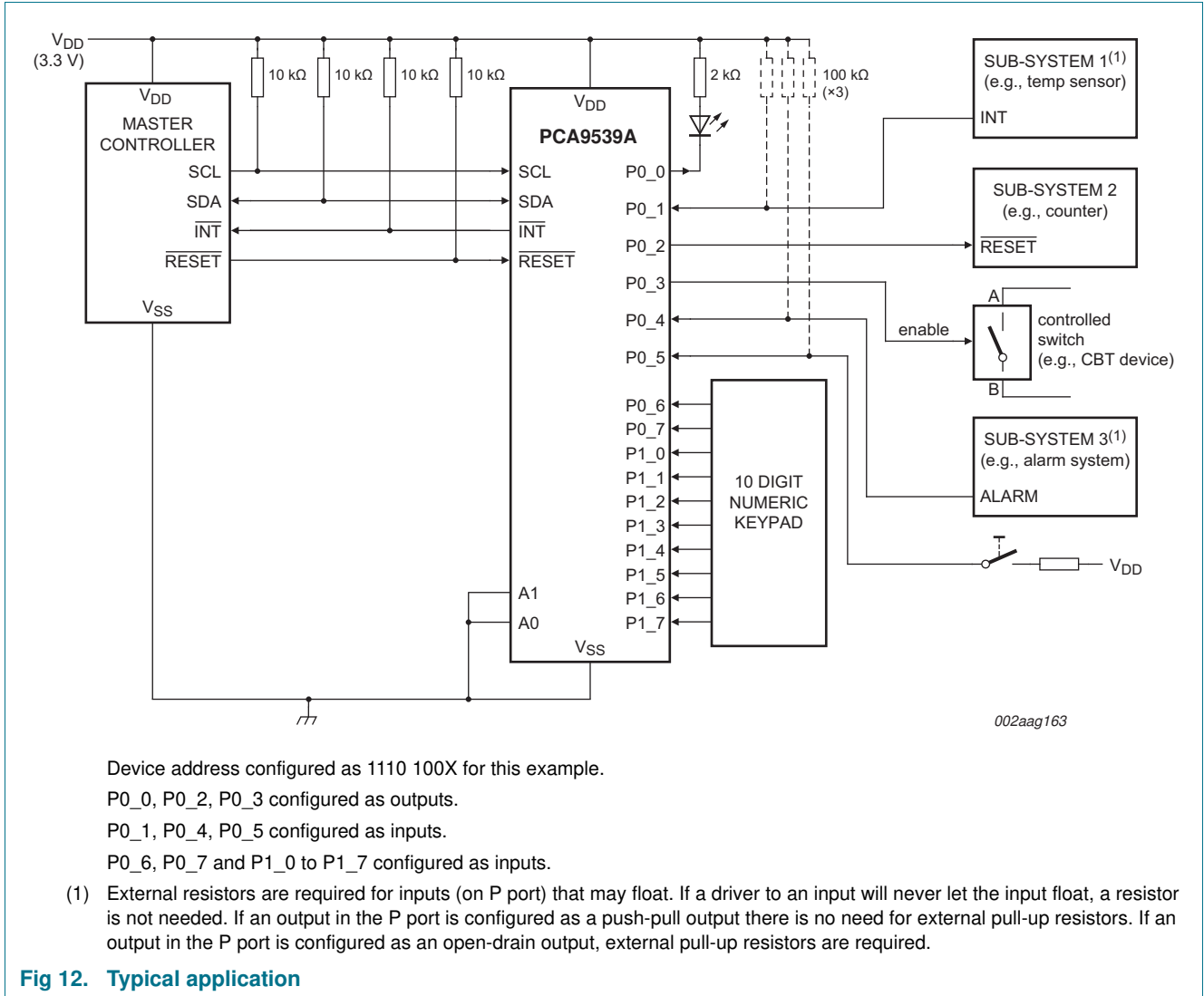

8.1 Minimizing I_{DD} when the I/Os are used to control LEDs

When the I/Os are used to control LEDs, they are normally connected to V_{DD} through a resistor as shown in Figure 12. Since the LED acts as a diode, when the LED is off the I/O V_I is about 1.2 V less than V_{DD}. The supply current, I_{DD}, increases as V_I becomes lower than V_{DD}.

Designs needing to minimize current consumption, such as battery power applications, should consider maintaining the I/O pins greater than or equal to V_{DD} when the LED is off. Figure 13 shows a high value resistor in parallel with the LED. Figure 14 shows V_{DD} less than the LED supply voltage by at least 1.2 V. Both of these methods maintain the I/O V_I at or above V_{DD} and prevents additional supply current consumption when the LED is off.

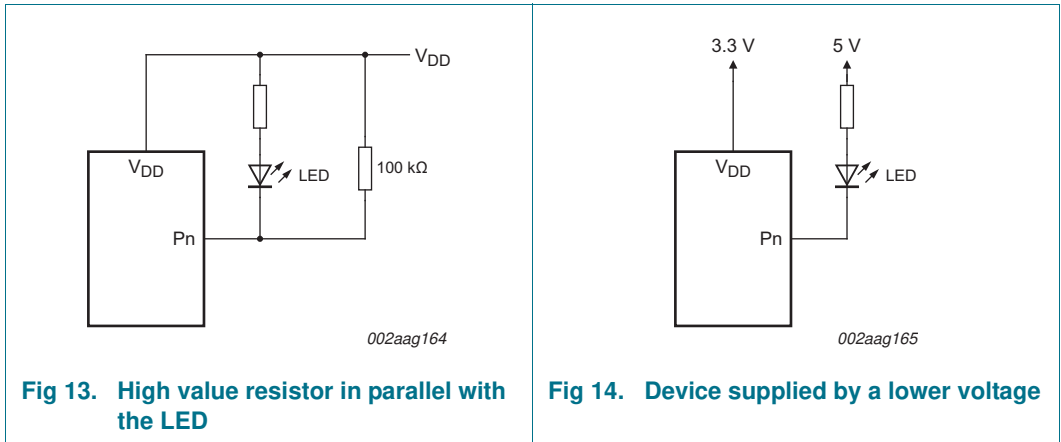

8.2 Power-on reset requirements

In the event of a glitch or data corruption, PCA9539A can be reset to its default conditions by using the power-on reset feature. Power-on reset requires that the device go through a power cycle to be completely reset. This reset also happens when the device is powered on for the first time in an application.

The two types of power-on reset are shown in [Figure 15](#) and [Figure 16](#).

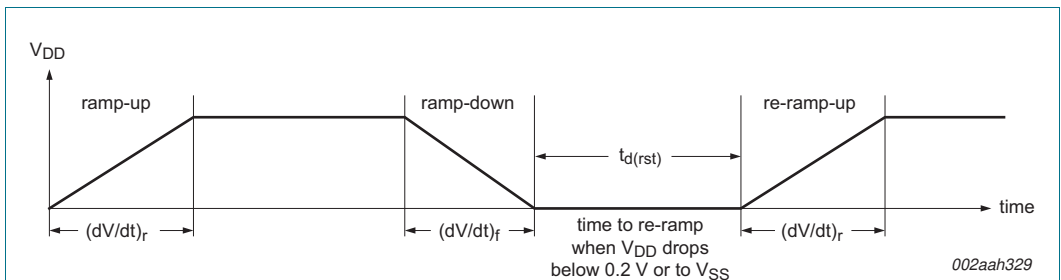

Fig 15. V_{DD} is lowered below 0.2 V or to 0 V and then ramped up to V_{DD}

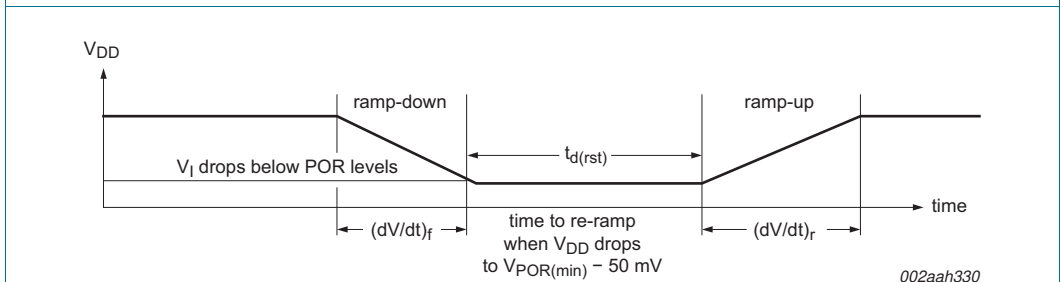

Fig 16. V_{DD} is lowered below the POR threshold, then ramped back up to V_{DD}

[Table 13](#) specifies the performance of the power-on reset feature for PCA9539A for both types of power-on reset.

Table 13. Recommended supply sequencing and ramp rates
T_{amb} = 25 °C (unless otherwise noted). Not tested; specified by design.

Symbol	Parameter	Condition	Min	Typ	Max	Unit
(dV/dt) _f	fall rate of change of voltage	Figure 15	0.1	-	2000	ms
(dV/dt) _r	rise rate of change of voltage	Figure 15	0.1	-	2000	ms
t _{d(rst)}	reset delay time	Figure 15 ; re-ramp time when V _{DD} drops below 0.2 V or to V _{SS}	1	-	-	μs
		Figure 16 ; re-ramp time when V _{DD} drops to V _{POR(min)} - 50 mV	1	-	-	μs
ΔV _{DD(gl)}	glitch supply voltage difference	Figure 17	[1]	-	1	V
t _{w(gl)VDD}	supply voltage glitch pulse width	Figure 17	[2]	-	10	μs
V _{POR(trip)}	power-on reset trip voltage	falling V _{DD}	0.7	-	-	V
		rising V _{DD}	-	-	1.4	V

- [1] Level that V_{DD} can glitch down to with a ramp rate of 0.4 μs/V, but not cause a functional disruption when t_{w(gl)VDD} < 1 μs.
- [2] Glitch width that will not cause a functional disruption when ΔV_{DD(gl)} = 0.5 × V_{DD}.

Glitches in the power supply can also affect the power-on reset performance of this device. The glitch width (t_{w(gl)VDD}) and glitch height (ΔV_{DD(gl)}) are dependent on each other. The bypass capacitance, source impedance, and device impedance are factors that affect power-on reset performance. [Figure 17](#) and [Table 13](#) provide more information on how to measure these specifications.

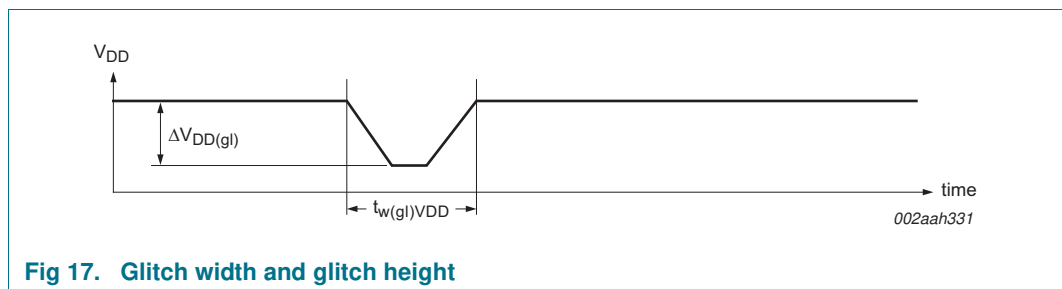

Fig 17. Glitch width and glitch height

V_{POR} is critical to the power-on reset. V_{POR} is the voltage level at which the reset condition is released and all the registers and the I²C-bus/SMBus state machine are initialized to their default states. The value of V_{POR} differs based on the V_{DD} being lowered to or from 0 V. [Figure 18](#) and [Table 13](#) provide more details on this specification.

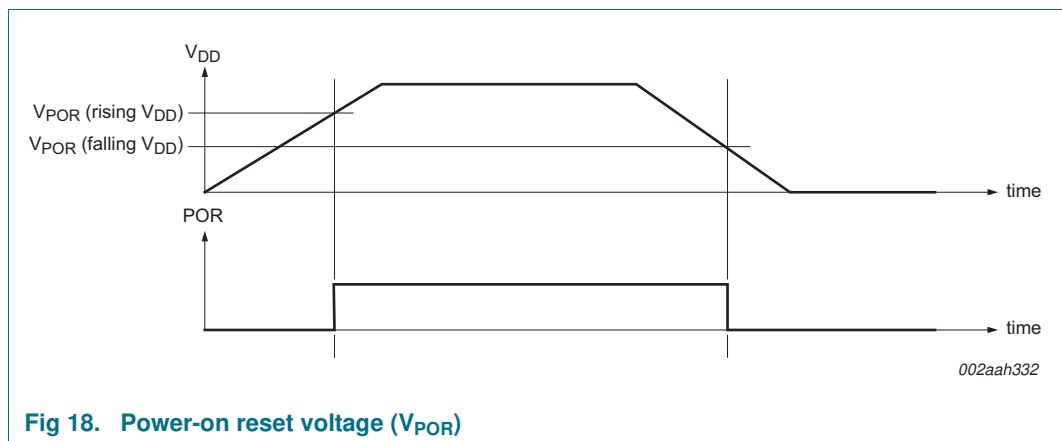

Fig 18. Power-on reset voltage (V_{POR})

9. Limiting values

Table 14. Limiting values

In accordance with the Absolute Maximum Rating System (IEC 60134).

Symbol	Parameter	Conditions	Min	Max	Unit
V _{DD}	supply voltage		-0.5	+6.5	V
V _I	input voltage		[1] -0.5	+6.5	V
V _O	output voltage		[1] -0.5	+6.5	V
I _{IK}	input clamping current	A0, A1, $\overline{\text{RESET}}$, SCL; V _I < 0 V	-	±20	mA
I _{OK}	output clamping current	$\overline{\text{INT}}$; V _O < 0 V	-	±20	mA
I _{IOK}	input/output clamping current	P port; V _O < 0 V or V _O > V _{DD}	-	±20	mA
		SDA; V _O < 0 V or V _O > V _{DD}	-	±20	mA
I _{OL}	LOW-level output current	continuous; I/O port	-	50	mA
		continuous; SDA, $\overline{\text{INT}}$	-	25	mA
I _{OH}	HIGH-level output current	continuous; P port	-	25	mA
I _{DD}	supply current		-	160	mA
I _{SS}	ground supply current		-	200	mA
P _{tot}	total power dissipation		-	200	mW
T _{stg}	storage temperature		-65	+150	°C
T _{j(max)}	maximum junction temperature		-	125	°C

[1] The input negative-voltage and output voltage ratings may be exceeded if the input and output current ratings are observed.

10. Recommended operating conditions

Table 15. Operating conditions

Symbol	Parameter	Conditions	Min	Max	Unit
V _{DD}	supply voltage		1.65	5.5	V
V _{IH}	HIGH-level input voltage	SCL, SDA, $\overline{\text{RESET}}$	0.7 × V _{DD}	5.5	V
		A0, A1, P1_7 to P0_0	0.7 × V _{DD}	5.5	V
V _{IL}	LOW-level input voltage	SCL, SDA, $\overline{\text{RESET}}$	-0.5	0.3 × V _{DD}	V
		A0, A1, P1_7 to P0_0	-0.5	0.3 × V _{DD}	V
I _{OH}	HIGH-level output current	P1_7 to P0_0	-	10	mA
I _{OL}	LOW-level output current	P1_7 to P0_0	-	25	mA
T _{amb}	ambient temperature	operating in free air	-40	+85	°C

11. Thermal characteristics

Table 16. Thermal characteristics

Symbol	Parameter	Conditions	Max	Unit
Z _{th(j-a)}	transient thermal impedance from junction to ambient	TSSOP24 package	[1] 88	K/W
		HWQFN24 package	[1] 66	K/W

[1] The package thermal impedance is calculated in accordance with JESD 51-7.

12. Static characteristics

Table 17. Static characteristics
 $T_{amb} = -40\text{ }^{\circ}\text{C to }+85\text{ }^{\circ}\text{C}; V_{DD} = 1.65\text{ V to }5.5\text{ V};$ unless otherwise specified.

Symbol	Parameter	Conditions	Min	Typ ^[1]	Max	Unit
V _{IK}	input clamping voltage	I _I = -18 mA	-1.2	-	-	V
V _{POR}	power-on reset voltage	V _I = V _{DD} or V _{SS} ; I _O = 0 mA	-	1.1	1.4	V
I _{OL}	LOW-level output current	V _{OL} = 0.4 V; V _{DD} = 1.65 V to 5.5 V				
		SDA	3	-	-	mA
		$\overline{\text{INT}}$	3	15 ^[2]	-	mA
		P port				
		V _{OL} = 0.5 V; V _{DD} = 1.65 V	^[3] 8	10	-	mA
		V _{OL} = 0.7 V; V _{DD} = 1.65 V	^[3] 10	13	-	mA
		V _{OL} = 0.5 V; V _{DD} = 2.3 V	^[3] 8	10	-	mA
		V _{OL} = 0.7 V; V _{DD} = 2.3 V	^[3] 10	13	-	mA
		V _{OL} = 0.5 V; V _{DD} = 3.0 V	^[3] 8	14	-	mA
		V _{OL} = 0.7 V; V _{DD} = 3.0 V	^[3] 10	19	-	mA
V _{OH}	HIGH-level output voltage	P port				
		I _{OH} = -8 mA; V _{DD} = 1.65 V	^[4] 1.2	-	-	V
		I _{OH} = -10 mA; V _{DD} = 1.65 V	^[4] 1.1	-	-	V
		I _{OH} = -8 mA; V _{DD} = 2.3 V	^[4] 1.8	-	-	V
		I _{OH} = -10 mA; V _{DD} = 2.3 V	^[4] 1.7	-	-	V
		I _{OH} = -8 mA; V _{DD} = 3.0 V	^[4] 2.6	-	-	V
		I _{OH} = -10 mA; V _{DD} = 3.0 V	^[4] 2.5	-	-	V
		I _{OH} = -8 mA; V _{DD} = 4.5 V	^[4] 4.1	-	-	V
V _{OL}	LOW-level output voltage	P port; I _{OL} = 8 mA				
		V _{DD} = 1.65 V	-	-	0.45	V
		V _{DD} = 2.5 V	-	-	0.25	V
		V _{DD} = 3.0 V	-	-	0.25	V
		V _{DD} = 4.5 V	-	-	0.2	V
I _I	input current	V _{DD} = 1.65 V to 5.5 V				
		SCL, SDA; V _I = V _{DD} or V _{SS}	-	-	±1	μA
		A0, A1, A2; V _I = V _{DD} or V _{SS}	-	-	±1	μA
I _{IH}	HIGH-level input current	P port; V _I = V _{DD} ; V _{DD} = 1.65 V to 5.5 V	-	-	1	μA
I _{IL}	LOW-level input current	P port; V _I = V _{SS} ; V _{DD} = 1.65 V to 5.5 V	-	-	1	μA

Table 17. Static characteristics ...continued

$T_{amb} = -40\text{ }^{\circ}\text{C}$ to $+85\text{ }^{\circ}\text{C}$; $V_{DD} = 1.65\text{ V}$ to 5.5 V ; unless otherwise specified.

Symbol	Parameter	Conditions	Min	Typ ^[1]	Max	Unit	
I_{DD}	supply current	SDA, P port, A0, A1, $\overline{\text{RESET}}$; V_I on SDA = V_{DD} or V_{SS} ; V_I on P port and A0, A1, $\overline{\text{RESET}} = V_{DD}$; $I_O = 0\text{ mA}$; I/O = inputs; $f_{SCL} = 400\text{ kHz}$					
		$V_{DD} = 3.6\text{ V}$ to 5.5 V	-	10	25	μA	
		$V_{DD} = 2.3\text{ V}$ to 3.6 V	-	6.5	15	μA	
		$V_{DD} = 1.65\text{ V}$ to 2.3 V	-	4	9	μA	
		SCL, SDA, P port, A0, A1, $\overline{\text{RESET}}$; V_I on SCL and SDA = V_{DD} or V_{SS} ; V_I on P port and A0, A1, $\overline{\text{RESET}} = V_{DD}$; $I_O = 0\text{ mA}$; I/O = inputs; $f_{SCL} = 0\text{ kHz}$					
		$V_{DD} = 3.6\text{ V}$ to 5.5 V	-	1.5	7	μA	
		$V_{DD} = 2.3\text{ V}$ to 3.6 V	-	1	3.2	μA	
		$V_{DD} = 1.65\text{ V}$ to 2.3 V	-	0.5	1.7	μA	
		Active mode; P port, A0, A1, $\overline{\text{RESET}}$; V_I on $\overline{\text{RESET}} = V_{DD}$; V_I on P port and A0, A1 = V_{DD} ; $I_O = 0\text{ mA}$; I/O = inputs; $f_{SCL} = 400\text{ kHz}$, continuous register read					
		$V_{DD} = 3.6\text{ V}$ to 5.5 V	-	60	125	μA	
		$V_{DD} = 2.3\text{ V}$ to 3.6 V	-	40	75	μA	
		$V_{DD} = 1.65\text{ V}$ to 2.3 V	-	20	45	μA	
ΔI_{DD}	additional quiescent supply current	SCL, SDA, $\overline{\text{RESET}}$; one input at $V_{DD} - 0.6\text{ V}$, other inputs at V_{DD} or V_{SS} ; $V_{DD} = 1.65\text{ V}$ to 5.5 V	-	-	25	μA	
		P port, A0, A1; one input at $V_{DD} - 0.6\text{ V}$, other inputs at V_{DD} or V_{SS} ; $V_{DD} = 1.65\text{ V}$ to 5.5 V	-	-	80	μA	
C_i	input capacitance	$V_I = V_{DD}$ or V_{SS} ; $V_{DD} = 1.65\text{ V}$ to 5.5 V	-	6	7	pF	
C_{io}	input/output capacitance	$V_{I/O} = V_{DD}$ or V_{SS} ; $V_{DD} = 1.65\text{ V}$ to 5.5 V	-	7	8	pF	
		$V_{I/O} = V_{DD}$ or V_{SS} ; $V_{DD} = 1.65\text{ V}$ to 5.5 V	-	7.5	8.5	pF	

- [1] For I_{DD} , all typical values are at nominal supply voltage (1.8 V, 2.5 V, 3.3 V, 3.6 V or 5 V V_{DD}) and $T_{amb} = 25\text{ }^{\circ}\text{C}$. Except for I_{DD} , the typical values are at $V_{DD} = 3.3\text{ V}$ and $T_{amb} = 25\text{ }^{\circ}\text{C}$.
- [2] Typical value for $T_{amb} = 25\text{ }^{\circ}\text{C}$. $V_{OL} = 0.4\text{ V}$ and $V_{DD} = 3.3\text{ V}$. Typical value for $V_{DD} < 2.5\text{ V}$, $V_{OL} = 0.6\text{ V}$.
- [3] Each I/O must be externally limited to a maximum of 25 mA and the device must be limited to a maximum current of 200 mA.
- [4] The total current sourced by all I/Os must be limited to 160 mA.

12.1 Typical characteristics

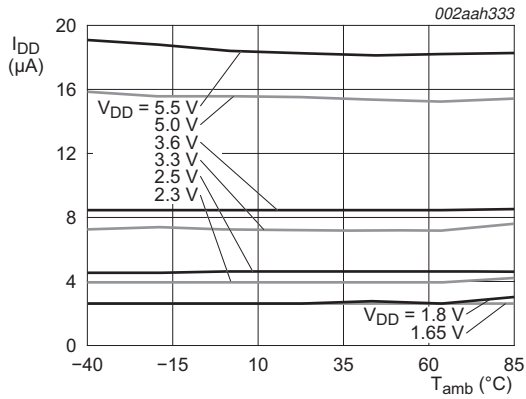

Fig 19. Supply current versus ambient temperature

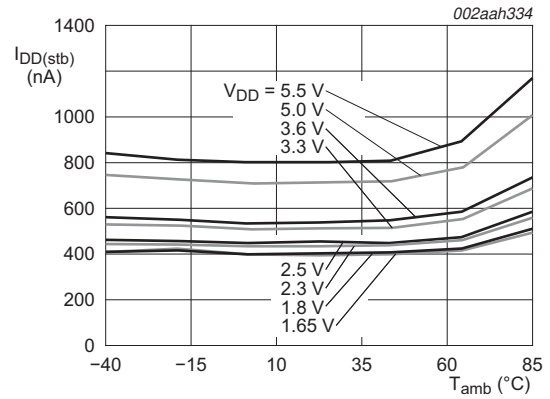
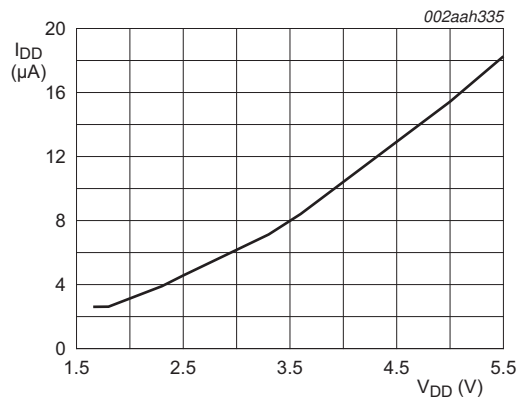
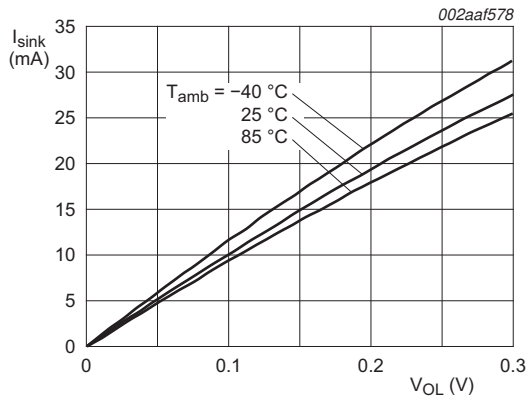

Fig 20. Standby supply current versus ambient temperature



$T_{amb} = 25^{\circ}C$

Fig 21. Supply current versus supply voltage



a. $V_{DD} = 1.65\text{ V}$

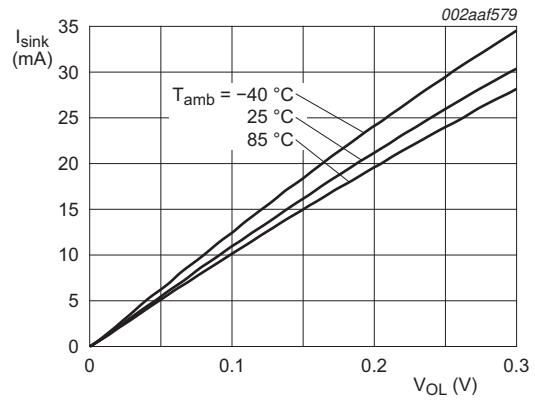

b. $V_{DD} = 1.8\text{ V}$

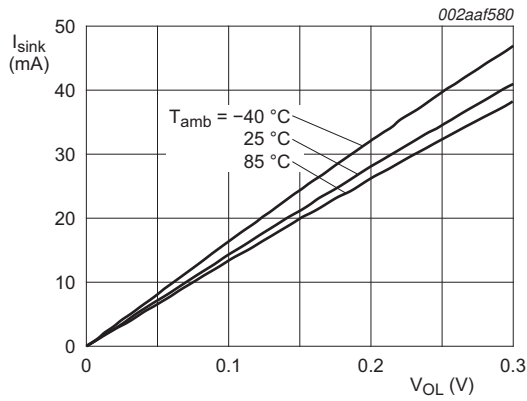

c. $V_{DD} = 2.5\text{ V}$

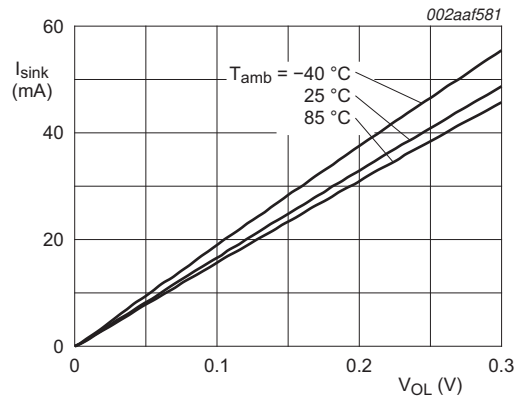

d. $V_{DD} = 3.3\text{ V}$

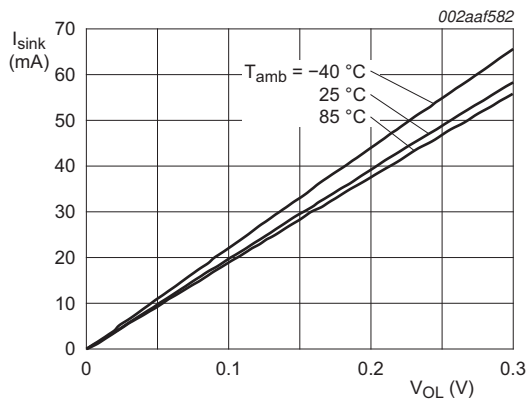

e. $V_{DD} = 5.0\text{ V}$

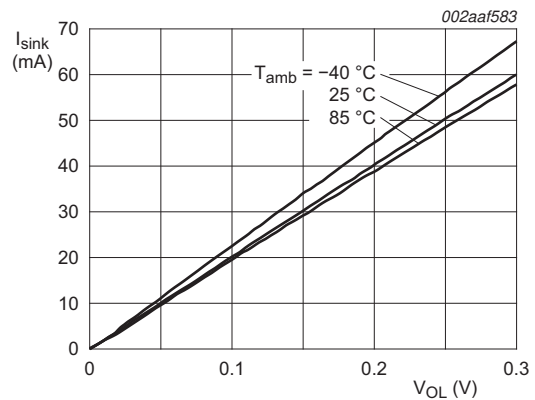

f. $V_{DD} = 5.5\text{ V}$

Fig 22. I/O sink current versus LOW-level output voltage

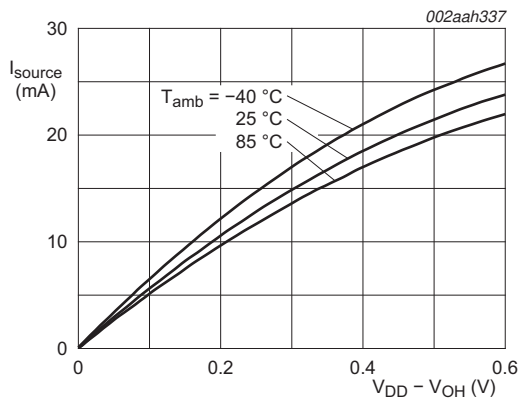

a. $V_{DD} = 1.65\text{ V}$

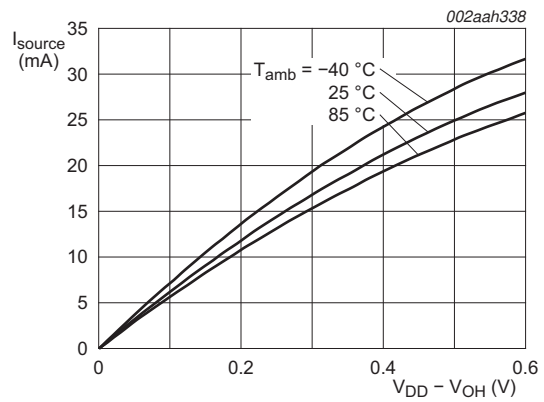

b. $V_{DD} = 1.8\text{ V}$

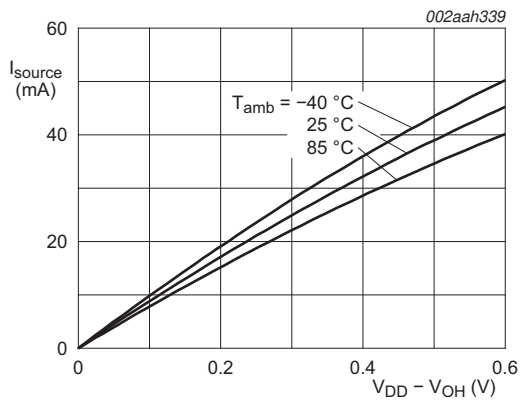

c. $V_{DD} = 2.5\text{ V}$

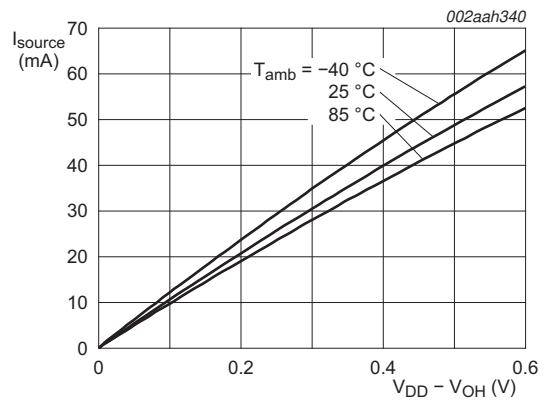

d. $V_{DD} = 3.3\text{ V}$

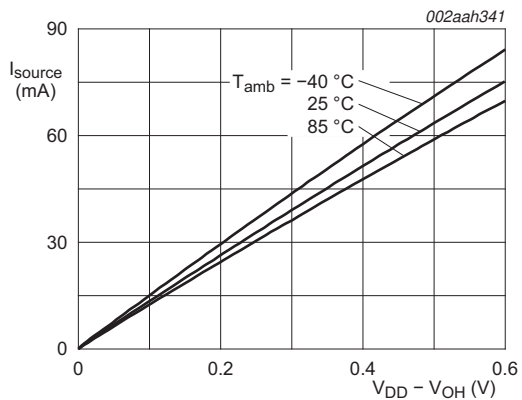

e. $V_{DD} = 5.0\text{ V}$

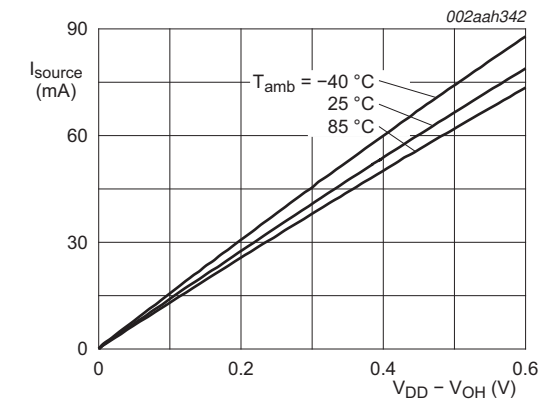

f. $V_{DD} = 5.5\text{ V}$

Fig 23. I/O source current versus HIGH-level output voltage

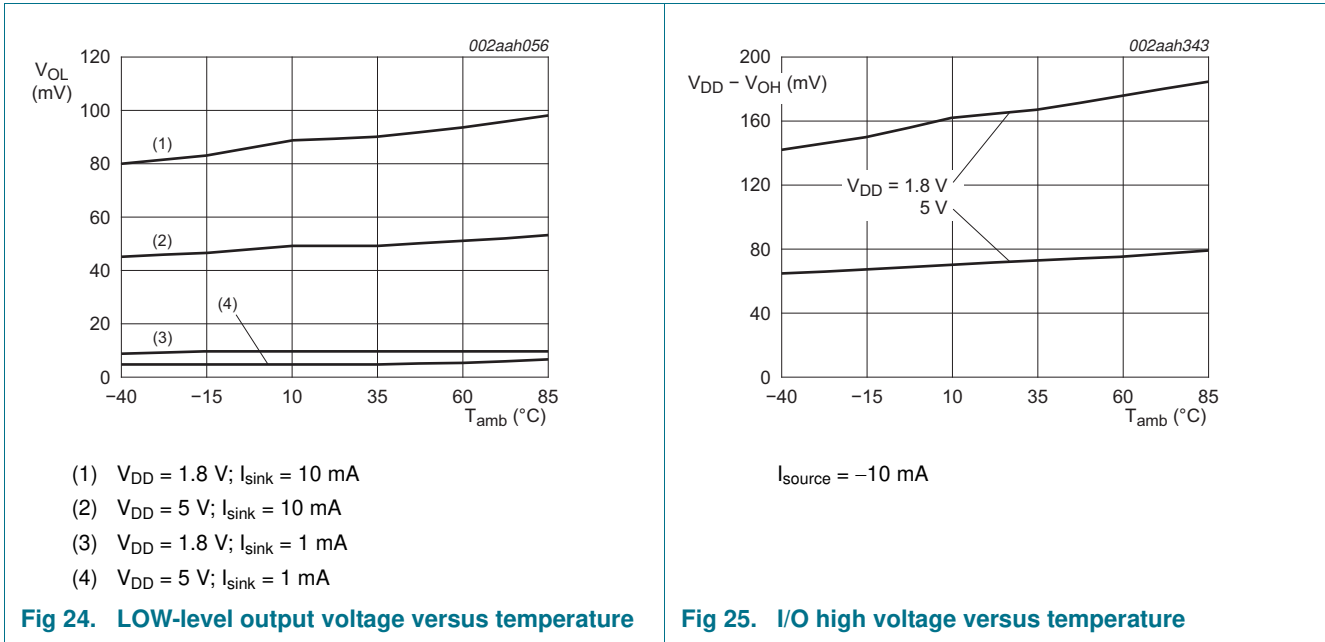

13. Dynamic characteristics

Table 18. I²C-bus interface timing requirements

Over recommended operating free air temperature range, unless otherwise specified. See [Figure 26](#).

Symbol	Parameter	Conditions	Standard-mode I ² C-bus		Fast-mode I ² C-bus		Unit
			Min	Max	Min	Max	
f _{SCL}	SCL clock frequency		0	100	0	400	kHz
t _{HIGH}	HIGH period of the SCL clock		4	-	0.6	-	μs
t _{LOW}	LOW period of the SCL clock		4.7	-	1.3	-	μs
t _{SP}	pulse width of spikes that must be suppressed by the input filter		0	50	0	50	ns
t _{SU;DAT}	data set-up time		250	-	100	-	ns
t _{HD;DAT}	data hold time		0	-	0	-	ns
t _r	rise time of both SDA and SCL signals		-	1000	20	300	ns
t _f	fall time of both SDA and SCL signals		-	300	20 × (V _{DD} / 5.5 V)	300	ns
t _{BUF}	bus free time between a STOP and START condition		4.7	-	1.3	-	μs
t _{SU;STA}	set-up time for a repeated START condition		4.7	-	0.6	-	μs
t _{HD;STA}	hold time (repeated) START condition		4	-	0.6	-	μs
t _{SU;STO}	set-up time for STOP condition		4	-	0.6	-	μs
t _{VD;DAT}	data valid time	SCL LOW to SDA output valid	-	3.45	-	0.9	μs
t _{VD;ACK}	data valid acknowledge time	ACK signal from SCL LOW to SDA (out) LOW	-	3.45	-	0.9	μs

Table 19. Reset timing requirements

Over recommended operating free air temperature range, unless otherwise specified. See [Figure 28](#).

Symbol	Parameter	Conditions	Standard-mode I ² C-bus		Fast-mode I ² C-bus		Unit
			Min	Max	Min	Max	
t _{w(rst)}	reset pulse width		30	-	30	-	ns
t _{rec(rst)}	reset recovery time		200	-	200	-	ns
t _{rst}	reset time	[1]	600	-	600	-	ns

[1] Minimum time for SDA to become HIGH or minimum time to wait before doing a START.

Table 20. Switching characteristics

Over recommended operating free air temperature range; $C_L \leq 100$ pF; unless otherwise specified. See [Figure 26](#).

Symbol	Parameter	Conditions	Standard-mode I ² C-bus		Fast-mode I ² C-bus		Unit
			Min	Max	Min	Max	
$t_{v(INT)}$	valid time on pin \overline{INT}	from P port to \overline{INT}	-	1	-	1	μ s
$t_{rst(INT)}$	reset time on pin \overline{INT}	from SCL to \overline{INT}	-	1	-	1	μ s
$t_{v(Q)}$	data output valid time	from SCL to P port	-	400	-	400	ns
$t_{su(D)}$	data input set-up time	from P port to SCL	0	-	0	-	ns
$t_{h(D)}$	data input hold time	from P port to SCL	300	-	300	-	ns

14. Parameter measurement information

