



Chipsmall Limited consists of a professional team with an average of over 10 year of expertise in the distribution of electronic components. Based in Hongkong, we have already established firm and mutual-benefit business relationships with customers from,Europe,America and south Asia,supplying obsolete and hard-to-find components to meet their specific needs.

With the principle of "Quality Parts,Customers Priority,Honest Operation,and Considerate Service",our business mainly focus on the distribution of electronic components. Line cards we deal with include Microchip,ALPS,ROHM,Xilinx,Pulse,ON,Everlight and Freescale. Main products comprise IC,Modules,Potentiometer,IC Socket,Relay,Connector.Our parts cover such applications as commercial,industrial, and automotives areas.

We are looking forward to setting up business relationship with you and hope to provide you with the best service and solution. Let us make a better world for our industry!



Contact us

Tel: +86-755-8981 8866 Fax: +86-755-8427 6832

Email & Skype: info@chipsmall.com Web: www.chipsmall.com

Address: A1208, Overseas Decoration Building, #122 Zhenhua RD., Futian, Shenzhen, China





PCA9543A/43B/43C

2-channel I²C-bus switch with interrupt logic and reset

Rev. 06 — 15 June 2009

Product data sheet

1. General description

The PCA9543A/43B/43C is a bidirectional translating switch, controlled by the I²C-bus. The SCL/SDA upstream pair fans out to two downstream pairs, or channels. Any individual SCx/SDx channels or combination of channels can be selected, determined by the contents of the programmable control register. Two interrupt inputs, $\overline{\text{INT0}}$ and $\overline{\text{INT1}}$, one for each of the downstream pairs, are provided. One interrupt output, $\overline{\text{INT}}$, which acts as an AND of the two interrupt inputs, is provided.

An active LOW reset input allows the PCA9543X to recover from a situation where one of the downstream I²C-buses is stuck in a LOW state. Pulling the $\overline{\text{RESET}}$ pin LOW resets the I²C-bus state machine and causes all the channels to be deselected, as does the internal power-on reset function.

The pass gates of the switches are constructed such that the V_{DD} pin can be used to limit the maximum high voltage which will be passed by the PCA9543X. This allows the use of different bus voltages on each SCx/SDx pair, so that 1.8 V, 2.5 V, or 3.3 V parts can communicate with 5 V parts without any additional protection. External pull-up resistors pull the bus up to the desired voltage level for each channel. All I/O pins are 5 V tolerant.

The PCA9543A, PCA9543B and PCA9543C are identical except for the fixed portion of the slave address.

2. Features

- 1-of-2 bidirectional translating switches
- I²C-bus interface logic; compatible with SMBus standards
- 2 active LOW interrupt inputs
- Active LOW interrupt output
- Active LOW reset input
- 2 address pins allowing up to 4 devices on the I²C-bus
- Alternate address versions A, B and C allow up to a total of 12 devices on the bus for larger systems or to resolve address conflicts
- Channel selection via I²C-bus, in any combination
- Power-up with all switch channels deselected
- Low R_{on} switches
- Allows voltage level translation between 1.8 V, 2.5 V, 3.3 V and 5 V buses
- No glitch on power-up
- Supports hot insertion
- Low standby current
- Operating power supply voltage range of 2.3 V to 5.5 V

- 5 V tolerant inputs
- 0 Hz to 400 kHz clock frequency
- ESD protection exceeds 2000 V HBM per JESD22-A114, 200 V MM per JESD22-A115, and 1000 V CDM per JESD22-C101
- Latch-up testing is done to JEDEC Standard JESD78 which exceeds 100 mA
- Packages offered: SO14, TSSOP14

3. Ordering information

Table 1. Ordering information

Type number	Package		Version
	Name	Description	
PCA9543AD	SO14	plastic small outline package; 14 leads; body width 3.9 mm	SOT108-1
PCA9543APW PCA9543BPW PCA9543CPW	TSSOP14	plastic thin shrink small outline package; 14 leads; body width 4.4 mm	SOT402-1

3.1 Ordering options

Table 2. Ordering options

Type number	Topside mark	Temperature range (T _{amb})
PCA9543AD	PCA9543AD	T _{amb} = -40 °C to +85 °C
PCA9543APW	PA9543A	T _{amb} = -40 °C to +85 °C
PCA9543BPW	PA9543B	T _{amb} = -40 °C to +85 °C
PCA9543CPW	PA9543C	T _{amb} = -40 °C to +85 °C

4. Block diagram

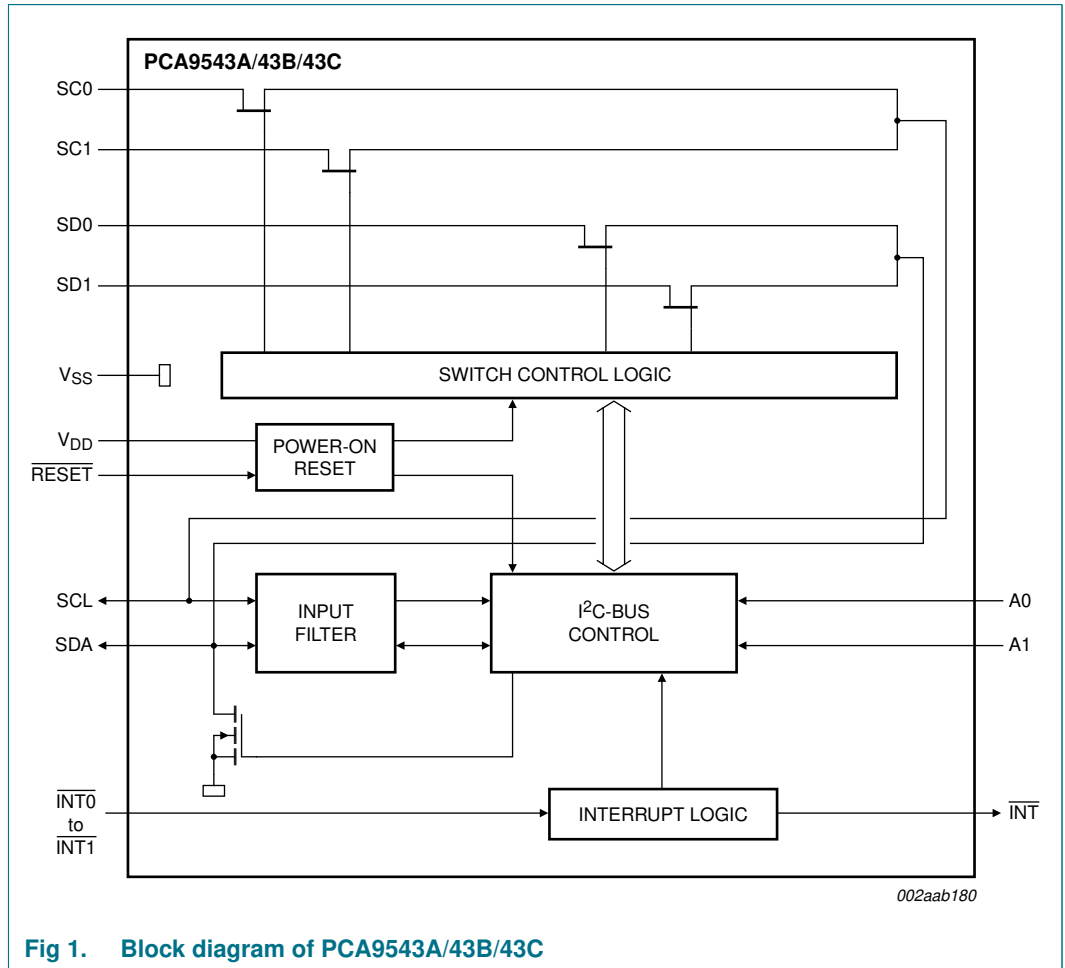

Fig 1. Block diagram of PCA9543A/43B/43C

5. Pinning information

5.1 Pinning

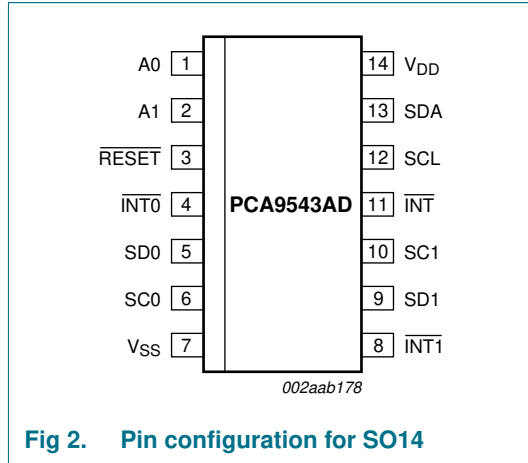

Fig 2. Pin configuration for SO14

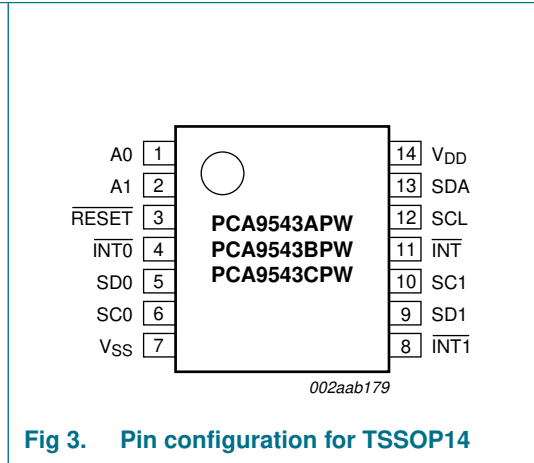

Fig 3. Pin configuration for TSSOP14

5.2 Pin description

Table 3. Pin description

Symbol	Pin	Description
A0	1	address input 0
A1	2	address input 1
RESET	3	active LOW reset input
INT ₀	4	active LOW interrupt input 0
SD0	5	serial data 0
SC0	6	serial clock 0
V _{SS}	7	supply ground
INT ₁	8	active LOW interrupt input 1
SD1	9	serial data 1
SC1	10	serial clock 1
INT	11	active LOW interrupt output
SCL	12	serial clock line
SDA	13	serial data line
V _{DD}	14	supply voltage

6. Functional description

Refer to [Figure 1 “Block diagram of PCA9543A/43B/43C”](#).

6.1 Device address

Following a START condition, the bus master must output the address of the slave it is accessing. The address of the PCA9543A is shown in [Figure 4](#). To conserve power, no internal pull-up resistors are incorporated on the hardware selectable address pins and they must be pulled HIGH or LOW.

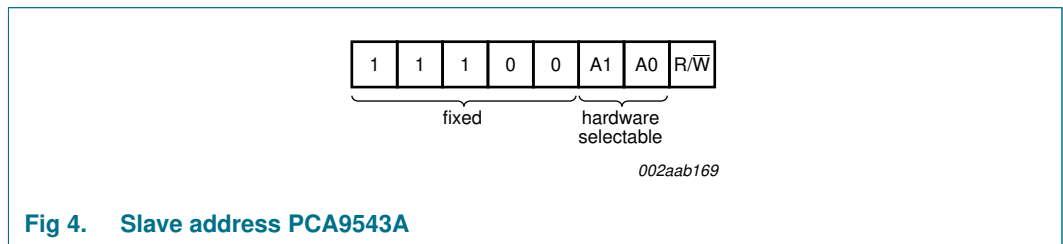

The last bit of the slave address defines the operation to be performed. When set to logic 1 a read is selected, while a logic 0 selects a write operation.

The PCA9543B and PCA9543C are alternate address versions if needed for larger systems or to resolve address conflicts. The data sheet will reference the PCA9543A, but the PCA9543B and PCA9543C function identically except for the slave address.

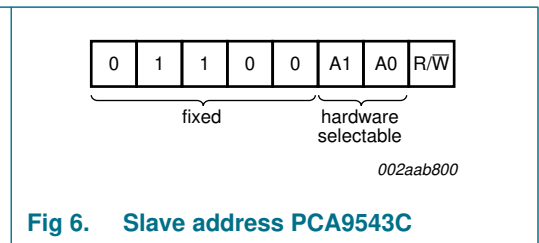
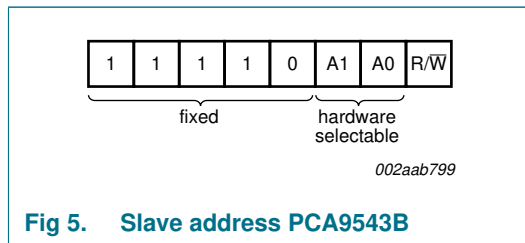

6.2 Control register

Following the successful acknowledgement of the slave address, the bus master will send a byte to the PCA9543A, which will be stored in the control register. If multiple bytes are received by the PCA9543A, it will save the last byte received. This register can be written and read via the I²C-bus.

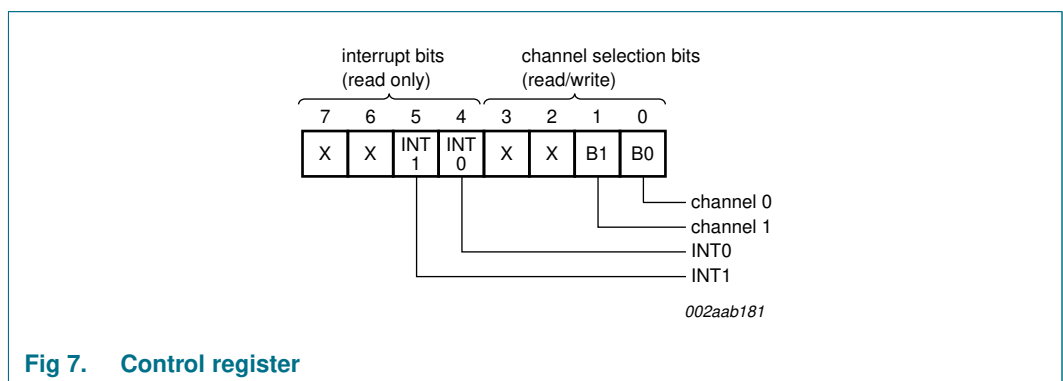

6.2.1 Control register definition

One or several SCx/SDx downstream pair, or channel, is selected by the contents of the control register. This register is written after the PCA9543A has been addressed. The 2 LSBs of the control byte are used to determine which channel is to be selected. When a channel is selected, the channel will become active after a STOP condition has been placed on the I²C-bus. This ensures that all SCx/SDx lines will be in a HIGH state when the channel is made active, so that no false conditions are generated at the time of connection.

Table 4. Control register: Write—channel selection; Read—channel status

D7	D6	INT1	INT0	D3	D2	B1	B0	Command
X	X	X	X	X	X	X	0	channel 0 disabled
							1	channel 0 enabled
X	X	X	X	X	X	0	X	channel 1 disabled
								1
0	0	0	0	0	0	0	0	no channel selected; power-up/reset default state

Remark: Channel 0 and channel 1 can be enabled at the same time. Care should be taken not to exceed the maximum bus capacitance.

6.2.2 Interrupt handling

The PCA9543A provides 2 interrupt inputs, one for each channel, and one open-drain interrupt output. When an interrupt is generated by any device, it will be detected by the PCA9543A and the interrupt output will be driven LOW. The channel need not be active for detection of the interrupt. A bit is also set in the control register.

Bit 4 and bit 5 of the control register corresponds to the $\overline{\text{INT0}}$ and $\overline{\text{INT1}}$ inputs of the PCA9543A, respectively. Therefore, if an interrupt is generated by any device connected to channel 1, the state of the interrupt inputs is loaded into the control register when a read is accomplished. Likewise, an interrupt on any device connected to channel 0 would cause bit 4 of the control register to be set on the read. The master can then address the PCA9543A and read the contents of the control register to determine which channel contains the device generating the interrupt. The master can then reconfigure the PCA9543A to select this channel, and locate the device generating the interrupt and clear it.

It should be noted that more than one device can provide an interrupt on a channel, so it is up to the master to ensure that all devices on a channel are interrogated for an interrupt.

The interrupt inputs may be used as general purpose inputs if the interrupt function is not required.

If unused, interrupt input(s) must be connected to V_{DD} through a pull-up resistor.

Table 5. Control register: Read—interrupt

7	6	INT1	INT0	3	2	B1	B0	Command
X	X	X	0	X	X	X	X	no interrupt on channel 0
			1					interrupt on channel 0
X	X	0	X	X	X	X	X	no interrupt on channel 1
		1						interrupt on channel 1

Remark: Two interrupts can be active at the same time.

6.3 RESET input

The $\overline{\text{RESET}}$ input is an active LOW signal which may be used to recover from a bus fault condition. By asserting this signal LOW for a minimum of $t_{w(\text{rst})L}$, the PCA9543A will reset its registers and I²C-bus state machine and will deselect all channels. The $\overline{\text{RESET}}$ input must be connected to V_{DD} through a pull-up resistor.

6.4 Power-on reset

When power is applied to V_{DD} , an internal Power-On Reset (POR) holds the PCA9543A in a reset condition until V_{DD} has reached V_{POR} . At this point, the reset condition is released and the PCA9543A registers and I²C-bus state machine are initialized to their default states (all zeroes) causing all the channels to be deselected. Thereafter, V_{DD} must be lowered below 0.2 V to reset the device.

6.5 Voltage translation

The pass gate transistors of the PCA9543A are constructed such that the V_{DD} voltage can be used to limit the maximum voltage that will be passed from one I²C-bus to another.

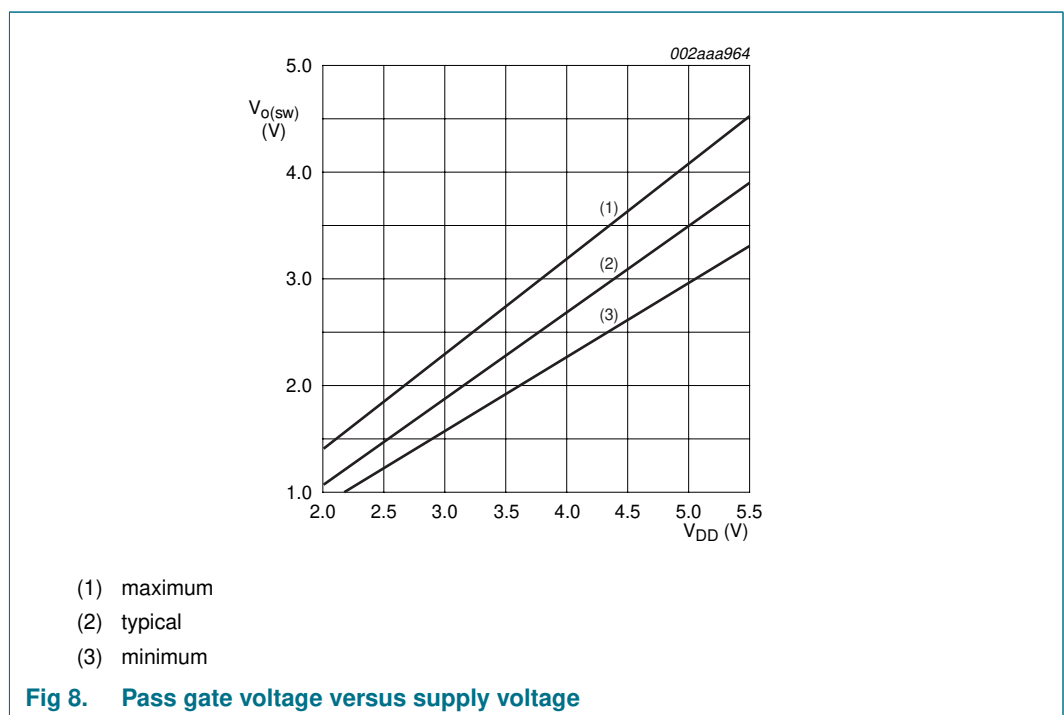

Figure 8 shows the voltage characteristics of the pass gate transistors (note that the graph was generated using the data specified in Section 10 “Static characteristics” of this data sheet). In order for the PCA9543A to act as a voltage translator, the $V_{o(\text{sw})}$ voltage should be equal to, or lower than the lowest bus voltage. For example, if the main bus was running at 5 V, and the downstream buses were 3.3 V and 2.7 V, then $V_{o(\text{sw})}$ should be equal to or below 2.7 V to effectively clamp the downstream bus voltages. Looking at

Figure 8, we see that $V_{o(sw)(max)}$ will be at 2.7 V when the PCA9543A supply voltage is 3.5 V or lower, so the PCA9543A supply voltage could be set to 3.3 V. Pull-up resistors can then be used to bring the bus voltages to their appropriate levels (see Figure 15).

More Information can be found in Application Note AN262: PCA954X family of I²C/SMBus multiplexers and switches.

7. Characteristics of the I²C-bus

The I²C-bus is for 2-way, 2-line communication between different ICs or modules. The two lines are a serial data line (SDA) and a serial clock line (SCL). Both lines must be connected to a positive supply via a pull-up resistor when connected to the output stages of a device. Data transfer may be initiated only when the bus is not busy.

7.1 Bit transfer

One data bit is transferred during each clock pulse. The data on the SDA line must remain stable during the HIGH period of the clock pulse as changes in the data line at this time will be interpreted as control signals (see Figure 9).

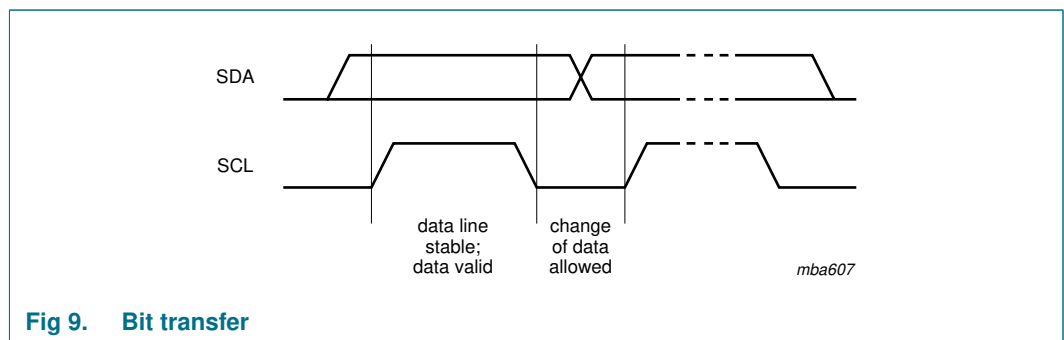

Fig 9. Bit transfer

7.2 START and STOP conditions

Both data and clock lines remain HIGH when the bus is not busy. A HIGH-to-LOW transition of the data line while the clock is HIGH is defined as the START condition (S). A LOW-to-HIGH transition of the data line while the clock is HIGH is defined as the STOP condition (P) (see Figure 10).

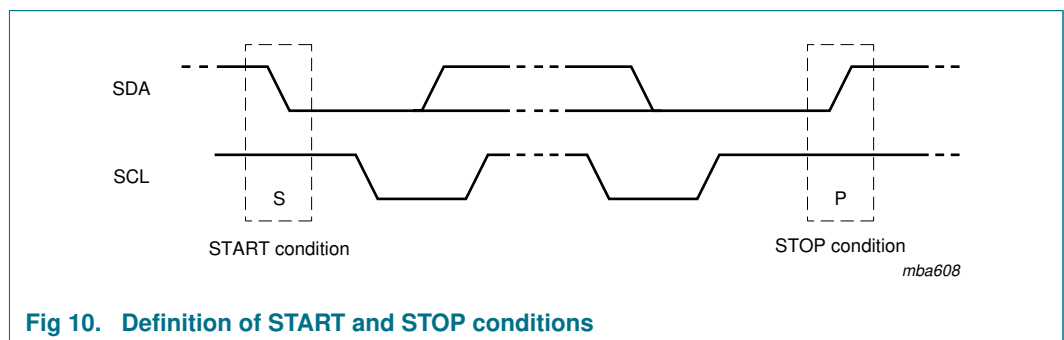

Fig 10. Definition of START and STOP conditions

7.3 System configuration

A device generating a message is a 'transmitter', a device receiving is the 'receiver'. The device that controls the message is the 'master' and the devices which are controlled by the master are the 'slaves' (see [Figure 11](#)).

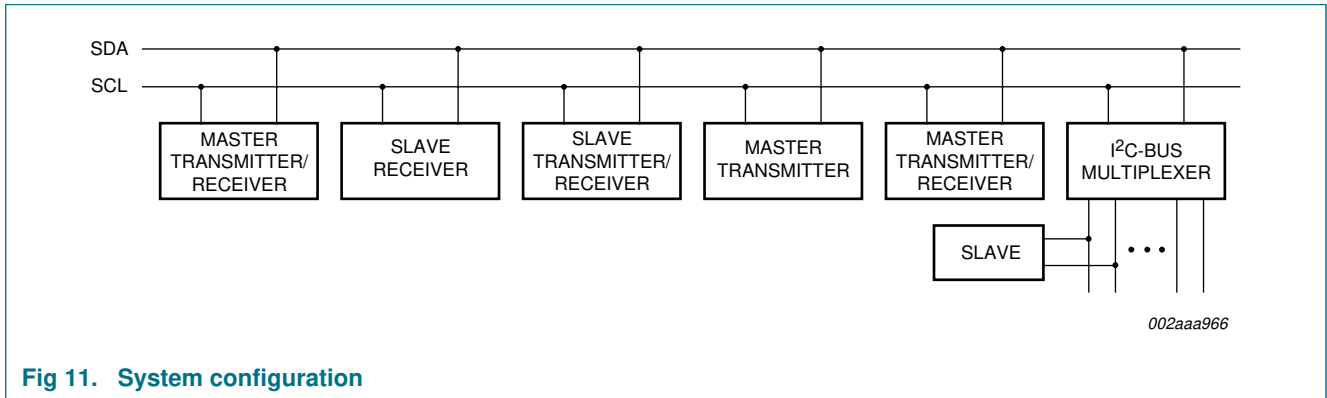

Fig 11. System configuration

7.4 Acknowledge

The number of data bytes transferred between the START and the STOP conditions from transmitter to receiver is not limited. Each byte of eight bits is followed by one acknowledge bit. The acknowledge bit is a HIGH level put on the bus by the transmitter, whereas the master generates an extra acknowledge related clock pulse.

A slave receiver which is addressed must generate an acknowledge after the reception of each byte. Also, a master must generate an acknowledge after the reception of each byte that has been clocked out of the slave transmitter. The device that acknowledges has to pull down the SDA line during the acknowledge clock pulse, so that the SDA line is stable LOW during the HIGH period of the acknowledge related clock pulse; set-up and hold times must be taken into account.

A master receiver must signal an end of data to the transmitter by not generating an acknowledge on the last byte that has been clocked out of the slave. In this event, the transmitter must leave the data line HIGH to enable the master to generate a STOP condition.

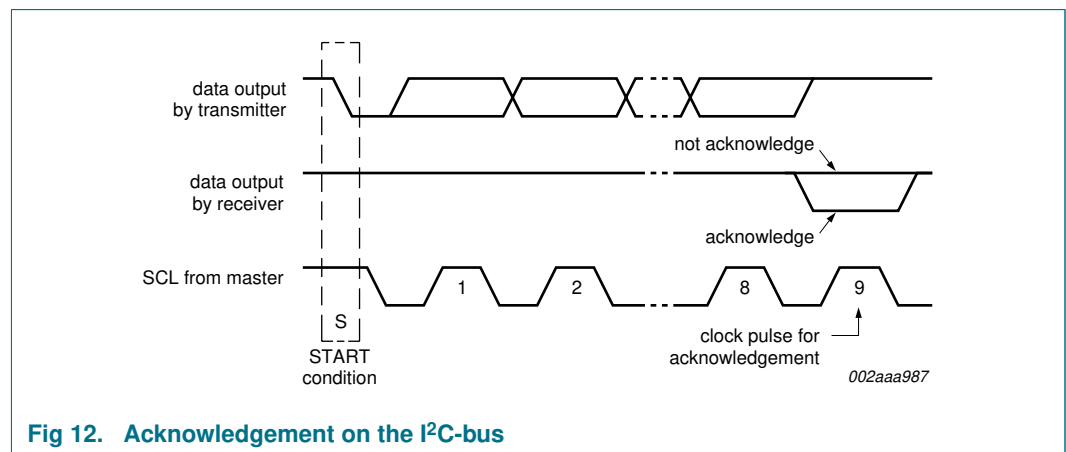
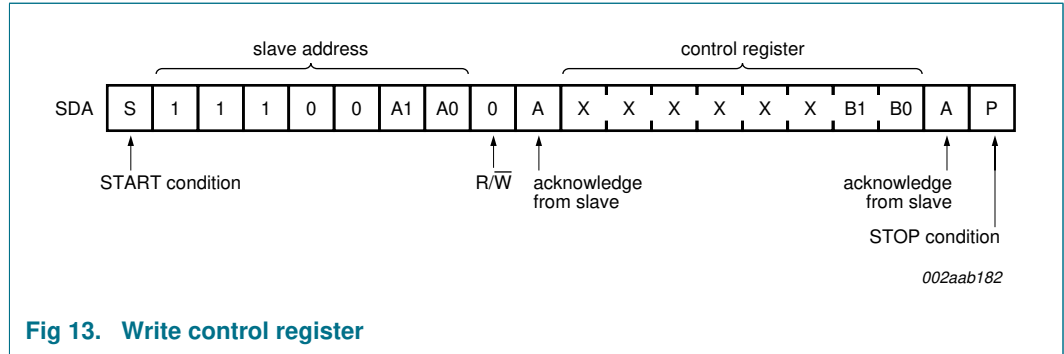

Fig 12. Acknowledgement on the I²C-bus

7.5 Bus transactions

Data is transmitted to the PCA9543A control register using the Write mode as shown in [Figure 13](#).



Data is read from PCA9543A using the Read mode as shown in [Figure 14](#).

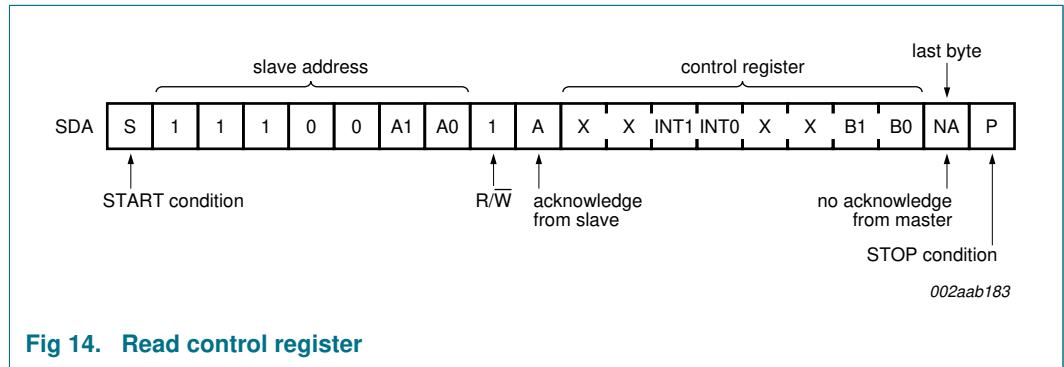

8. Application design-in information

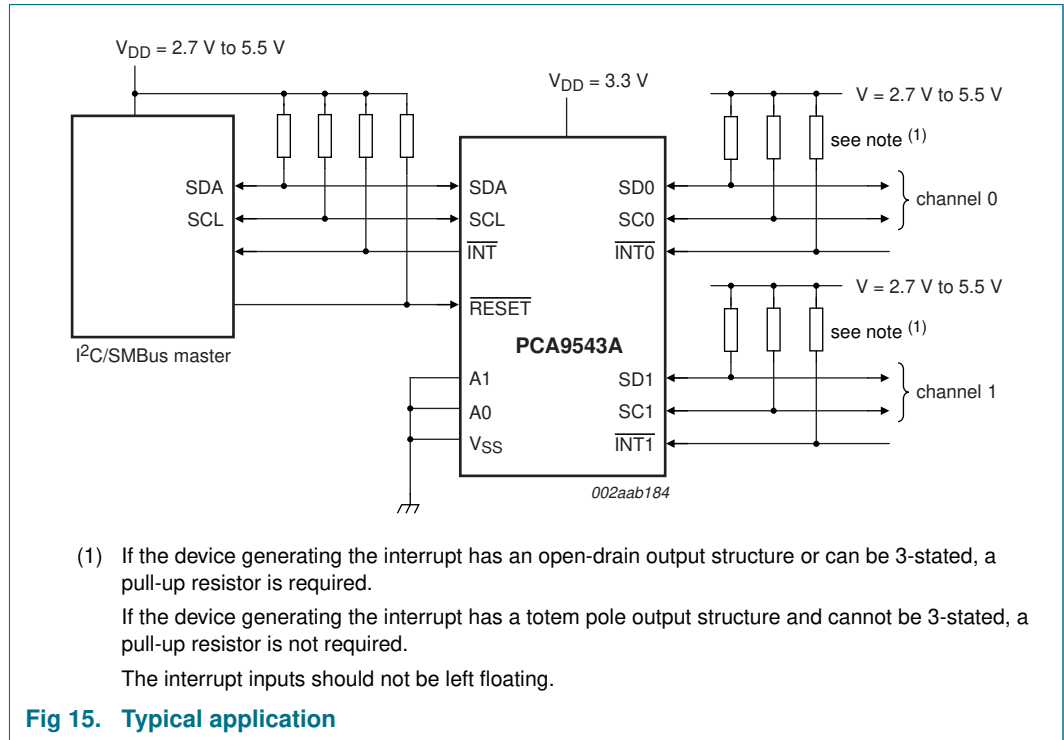

9. Limiting values

Table 6. Limiting values

In accordance with the Absolute Maximum Rating System (IEC 60134). Voltages are referenced to V_{SS} (ground = 0 V).^[1]

Symbol	Parameter	Conditions	Min	Max	Unit
V _{DD}	supply voltage		-0.5	+7.0	V
V _I	input voltage		-0.5	+7.0	V
I _I	input current		-	±20	mA
I _O	output current		-	±25	mA
I _{DD}	supply current		-	±100	mA
I _{SS}	ground supply current		-	±100	mA
P _{tot}	total power dissipation		-	400	mW
T _{stg}	storage temperature		-60	+150	°C
T _{amb}	ambient temperature	operating	-40	+85	°C

[1] The performance capability of a high-performance integrated circuit in conjunction with its thermal environment can create junction temperatures which are detrimental to reliability. The maximum junction temperature of this integrated circuit should not exceed 125 °C.

10. Static characteristics

Table 7. Static characteristics at V_{DD} = 2.3 V to 3.6 V

V_{SS} = 0 V; T_{amb} = -40 °C to +85 °C; unless otherwise specified. See [Table 8 on page 13](#) for V_{DD} = 4.5 V to 5.5 V.^[1]

Symbol	Parameter	Conditions	Min	Typ	Max	Unit
Supply						
V _{DD}	supply voltage		2.3	-	3.6	V
I _{DD}	supply current	operating mode; V _{DD} = 3.6 V; no load; V _I = V _{DD} or V _{SS} ; f _{SCL} = 100 kHz	-	40	100	μA
I _{stb}	standby current	Standby mode; V _{DD} = 3.6 V; no load; V _I = V _{DD} or V _{SS} ; f _{SCL} = 0 kHz	-	0.2	1	μA
V _{POR}	power-on reset voltage	no load; V _I = V _{DD} or V _{SS}	[2] -	1.6	2.1	V
Input SCL; input/output SDA						
V _{IL}	LOW-level input voltage		-0.5	-	+0.3V _{DD}	V
V _{IH}	HIGH-level input voltage		0.7V _{DD}	-	6	V
I _{OL}	LOW-level output current	V _{OL} = 0.4 V	3	-	-	mA
		V _{OL} = 0.6 V	6	-	-	mA
I _L	leakage current	V _I = V _{DD} or V _{SS}	-1	-	+1	μA
C _i	input capacitance	V _I = V _{SS}	-	9	10	pF
Select inputs A0, A1, INT0, INT1, RESET						
V _{IL}	LOW-level input voltage		-0.5	-	+0.3V _{DD}	V
V _{IH}	HIGH-level input voltage		0.7V _{DD}	-	V _{DD} + 0.5	V
I _{LI}	input leakage current	V _I = V _{DD} or V _{SS}	-1	-	+1	μA
C _i	input capacitance	V _I = V _{SS}	-	1.6	3	pF
Pass gate						
R _{on}	ON-state resistance	V _{DD} = 3.0 to 3.6 V; V _O = 0.4 V; I _O = 15 mA	5	11	30	Ω
		V _{DD} = 2.3 V to 2.7 V; V _O = 0.4 V; I _O = 10 mA	7	16	55	Ω
V _{O(sw)}	switch output voltage	V _{i(sw)} = V _{DD} = 3.3 V; I _{o(sw)} = -100 μA	-	1.9	-	V
		V _{i(sw)} = V _{DD} = 3.0 V to 3.6 V; I _{o(sw)} = -100 μA	1.6	-	2.8	V
		V _{i(sw)} = V _{DD} = 2.5 V; I _{o(sw)} = -100 μA	-	1.5	-	V
		V _{i(sw)} = V _{DD} = 2.5 V to 2.7 V; I _{o(sw)} = -100 μA	1.1	-	2.0	V
I _L	leakage current	V _I = V _{DD} or V _{SS}	-1	-	+1	μA
C _{io}	input/output capacitance	V _I = V _{SS}	-	3	5	pF
INT output						
I _{OL}	LOW-level output current	V _{OL} = 0.4 V	3	-	-	mA
I _{OH}	HIGH-level output current		-	-	+100	μA

[1] For operation between published voltage ranges, refer to the worst-case parameter in both ranges.

[2] V_{DD} must be lowered to 0.2 V in order to reset part.

Table 8. Static characteristics at V_{DD} = 4.5 V to 5.5 VV_{SS} = 0 V; T_{amb} = -40 °C to +85 °C; unless otherwise specified. See [Table 7 on page 12](#) for V_{DD} = 2.3 V to 3.6 V^[1]

Symbol	Parameter	Conditions	Min	Typ	Max	Unit
Supply						
V _{DD}	supply voltage		4.5	-	5.5	V
I _{DD}	supply current	Operating mode; V _{DD} = 5.5 V; no load; V _I = V _{DD} or V _{SS} ; f _{SCL} = 100 kHz	-	25	100	μA
I _{stb}	standby current	Standby mode; V _{DD} = 5.5 V; no load; V _I = V _{DD} or V _{SS} ; f _{SCL} = 0 kHz	-	0.2	1	μA
V _{POR}	power-on reset voltage	no load; V _I = V _{DD} or V _{SS}	[2] -	1.7	2.1	V
Input SCL; input/output SDA						
V _{IL}	LOW-level input voltage		-0.5	-	+0.3V _{DD}	V
V _{IH}	HIGH-level input voltage		0.7V _{DD}	-	6	V
I _{OL}	LOW-level output current	V _{OL} = 0.4 V	3	-	-	mA
		V _{OL} = 0.6 V	6	-	-	mA
I _L	leakage current	V _I = V _{DD} or V _{SS}	-1	-	+1	μA
C _i	input capacitance	V _I = V _{SS}	-	9	10	pF
Select inputs A0, A1, INT0 to INT3, RESET						
V _{IL}	LOW-level input voltage		-0.5	-	+0.3V _{DD}	V
V _{IH}	HIGH-level input voltage		0.7V _{DD}	-	V _{DD} + 0.5	V
I _{LI}	input leakage current	V _I = V _{DD} or V _{SS}	-1	-	+50	μA
C _i	input capacitance	V _I = V _{SS}	-	2	5	pF
Pass gate						
R _{on}	on-state resistance	V _{DD} = 4.5 V to 5.5 V; V _O = 0.4 V; I _O = 15 mA	4	9	24	Ω
V _{o(sw)}	switch output voltage	V _{i(sw)} = V _{DD} = 5.0 V; I _{o(sw)} = -100 μA	-	3.6	-	V
		V _{i(sw)} = V _{DD} = 4.5 V to 5.5 V; I _{o(sw)} = -100 μA	2.6	-	4.5	V
I _L	leakage current	V _I = V _{DD} or V _{SS}	-1	-	+100	μA
C _{io}	input/output capacitance	V _I = V _{SS}	-	3	5	pF
INT output						
I _{OL}	LOW-level output current	V _{OL} = 0.4 V	3	-	-	mA
I _{OH}	HIGH-level output current		-	-	+100	μA

[1] For operation between published voltage ranges, refer to the worst-case parameter in both ranges.

[2] V_{DD} must be lowered to 0.2 V in order to reset part.

11. Dynamic characteristics

Table 9. Dynamic characteristics

Symbol	Parameter	Conditions	Standard-mode I ² C-bus		Fast-mode I ² C-bus		Unit	
			Min	Max	Min	Max		
t _{PD}	propagation delay	from SDA to SDx, or SCL to SCx	-	0.3 ^[1]	-	0.3 ^[1]	ns	
f _{SCL}	SCL clock frequency		0	100	0	400	kHz	
t _{BUF}	bus free time between a STOP and START condition		4.7	-	1.3	-	μs	
t _{HD;STA}	hold time (repeated) START condition	^[2]	4.0	-	0.6	-	μs	
t _{LOW}	LOW period of the SCL clock		4.7	-	1.3	-	μs	
t _{HIGH}	HIGH period of the SCL clock		4.0	-	0.6	-	μs	
t _{SU;STA}	set-up time for a repeated START condition		4.7	-	0.6	-	μs	
t _{SU;STO}	set-up time for STOP condition		4.0	-	0.6	-	μs	
t _{HD;DAT}	data hold time		0 ^[3]	3.45	0 ^[3]	0.9	μs	
t _{SU;DAT}	data set-up time		250	-	100	-	ns	
t _r	rise time of both SDA and SCL signals		-	1000	20 + 0.1C _b ^[4]	300	ns	
t _f	fall time of both SDA and SCL signals		-	300	20 + 0.1C _b ^[4]	300	ns	
C _b	capacitive load for each bus line		-	400	-	400	pF	
t _{SP}	pulse width of spikes that must be suppressed by the input filter		-	50	-	50	ns	
t _{V_D;DAT}	data valid time	HIGH-to-LOW	^[5]	-	1	-	1	μs
		LOW-to-HIGH	^[5]	-	0.6	-	0.6	μs
t _{V_D;ACK}	data valid acknowledge time		-	1	-	1	μs	
INT								
t _{v(IN_{Tn}-INTN)}	valid time from $\overline{\text{INTn}}$ to $\overline{\text{INT}}$ signal		-	4	-	4	μs	
t _{d(IN_{Tn}-INTN)}	delay time from $\overline{\text{INTn}}$ to $\overline{\text{INT}}$ inactive		-	2	-	2	μs	
t _{w(rej)L}	LOW-level rejection time	$\overline{\text{INTn}}$ inputs	1	-	1	-	μs	
t _{w(rej)H}	HIGH-level rejection time	$\overline{\text{INTn}}$ inputs	0.5	-	0.5	-	μs	
RESET								
t _{w(rst)L}	LOW-level reset time		4	-	4	-	ns	
t _{rst}	reset time	SDA clear	500	-	500	-	ns	
t _{REC;STA}	recovery time to START condition		0	-	0	-	ns	

[1] Pass gate propagation delay is calculated from the 20 Ω typical R_{on} and the 15 pF load capacitance.

[2] Hold time (repeated) START condition. After this period, the first clock pulse is generated.

[3] A device must internally provide a hold time of at least 300 ns for the SDA signal (referred to the V_{IH(min)} of the SCL signal) in order to bridge the undefined region of the falling edge of SCL.

[4] C_b = total capacitance of one bus line in pF.

[5] Measurements taken with 1 kΩ pull-up resistor and 50 pF load.

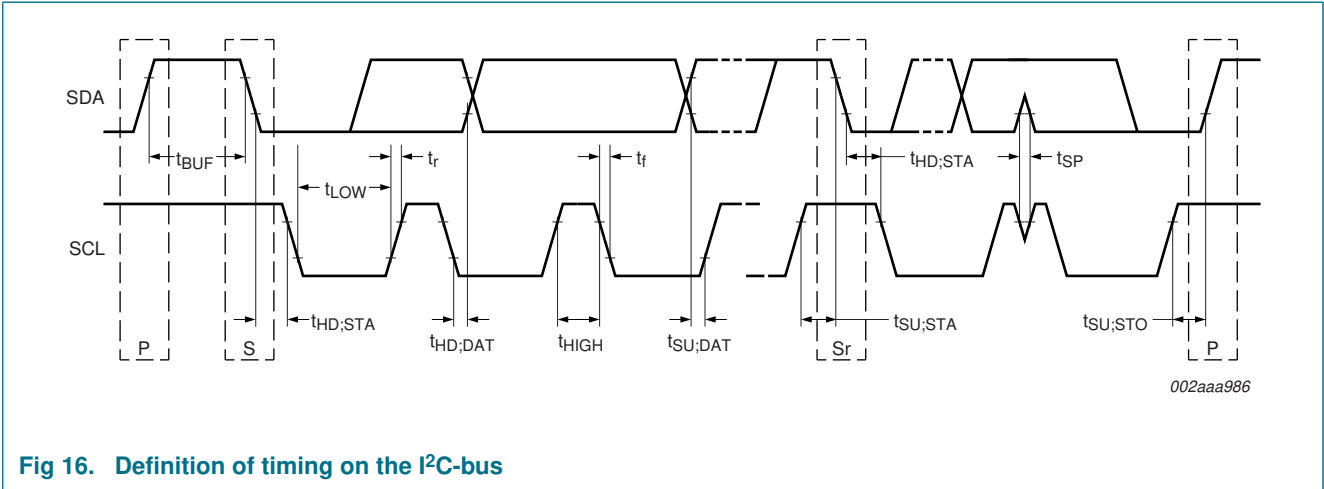

Fig 16. Definition of timing on the I²C-bus

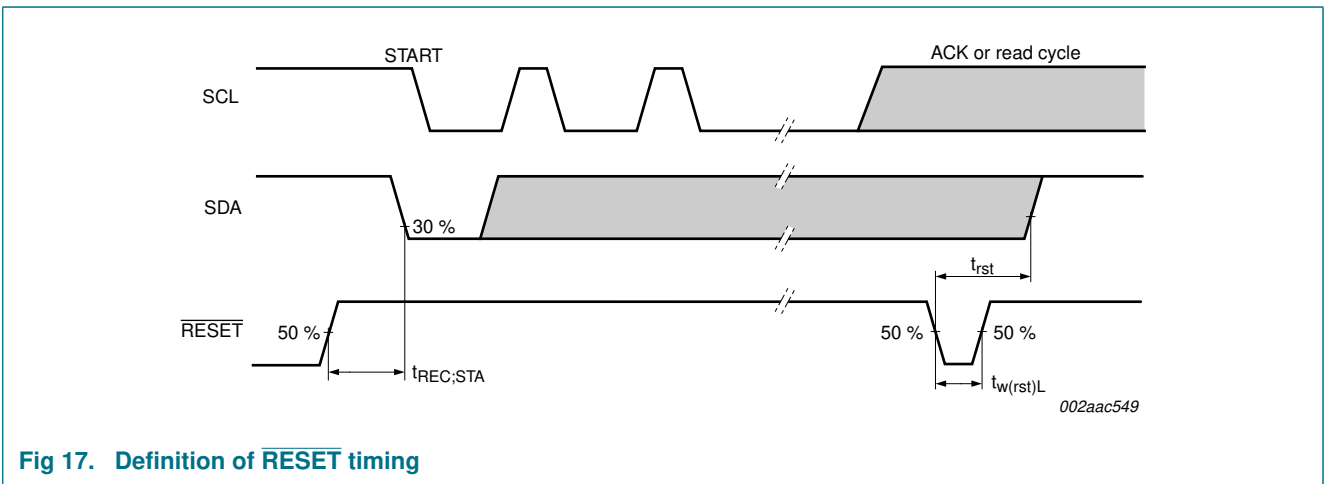

Fig 17. Definition of RESET timing

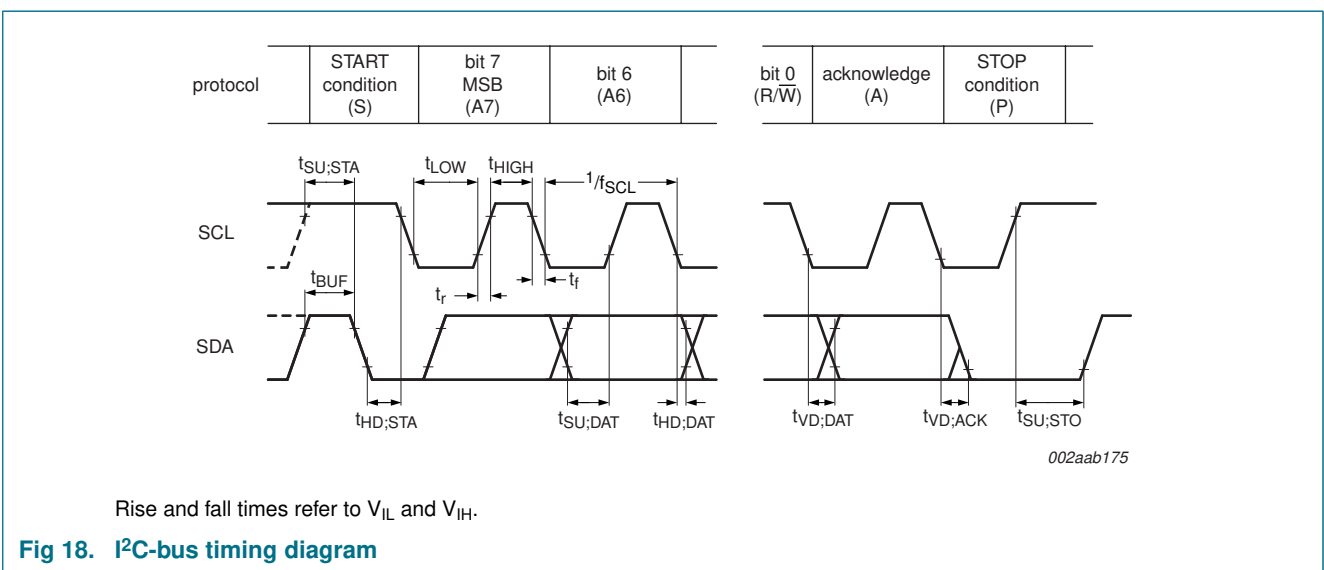

Fig 18. I²C-bus timing diagram

12. Package outline

SO14: plastic small outline package; 14 leads; body width 3.9 mm

SOT108-1

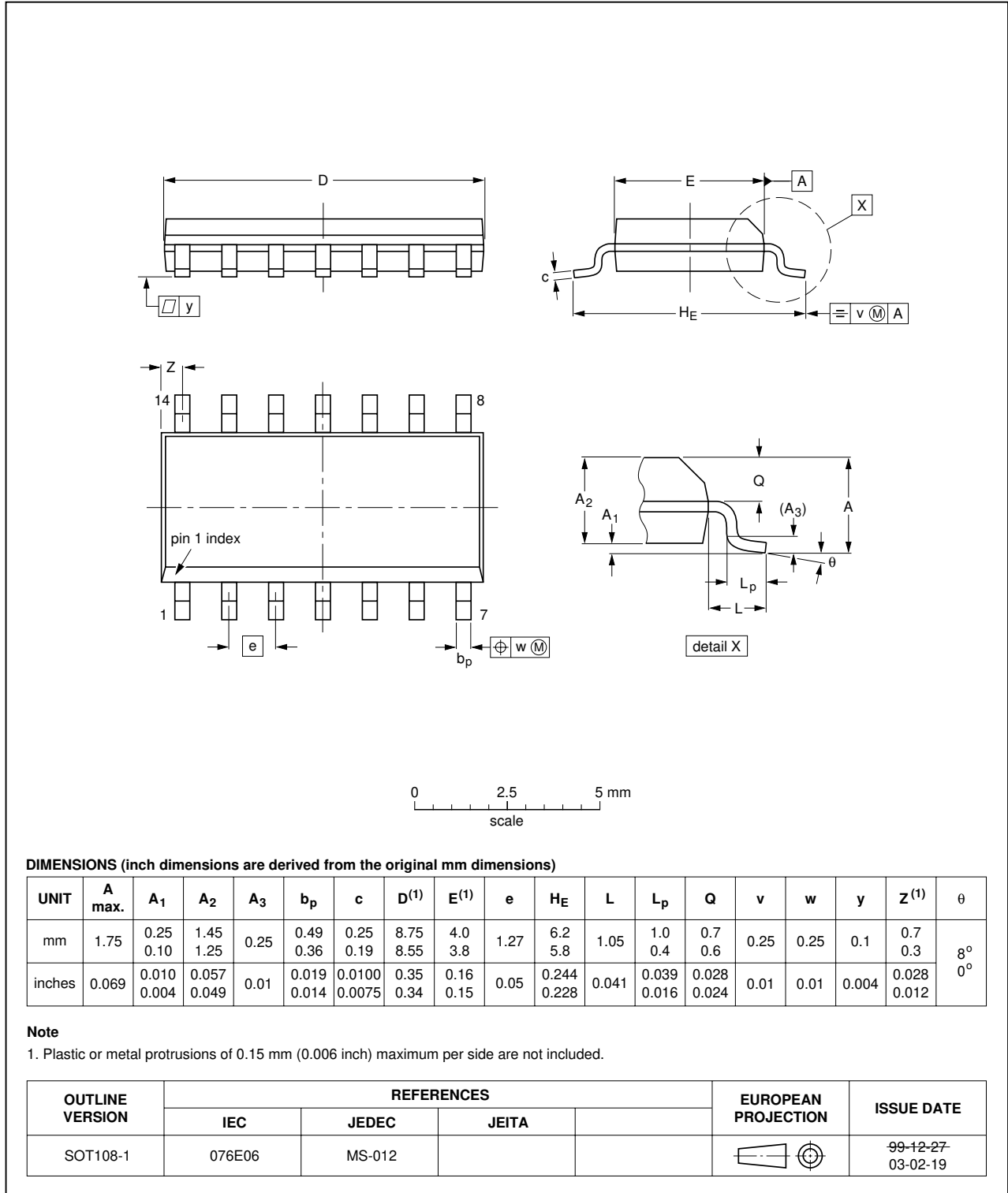

Fig 19. Package outline SOT108-1 (SO14)

TSSOP14: plastic thin shrink small outline package; 14 leads; body width 4.4 mm

SOT402-1

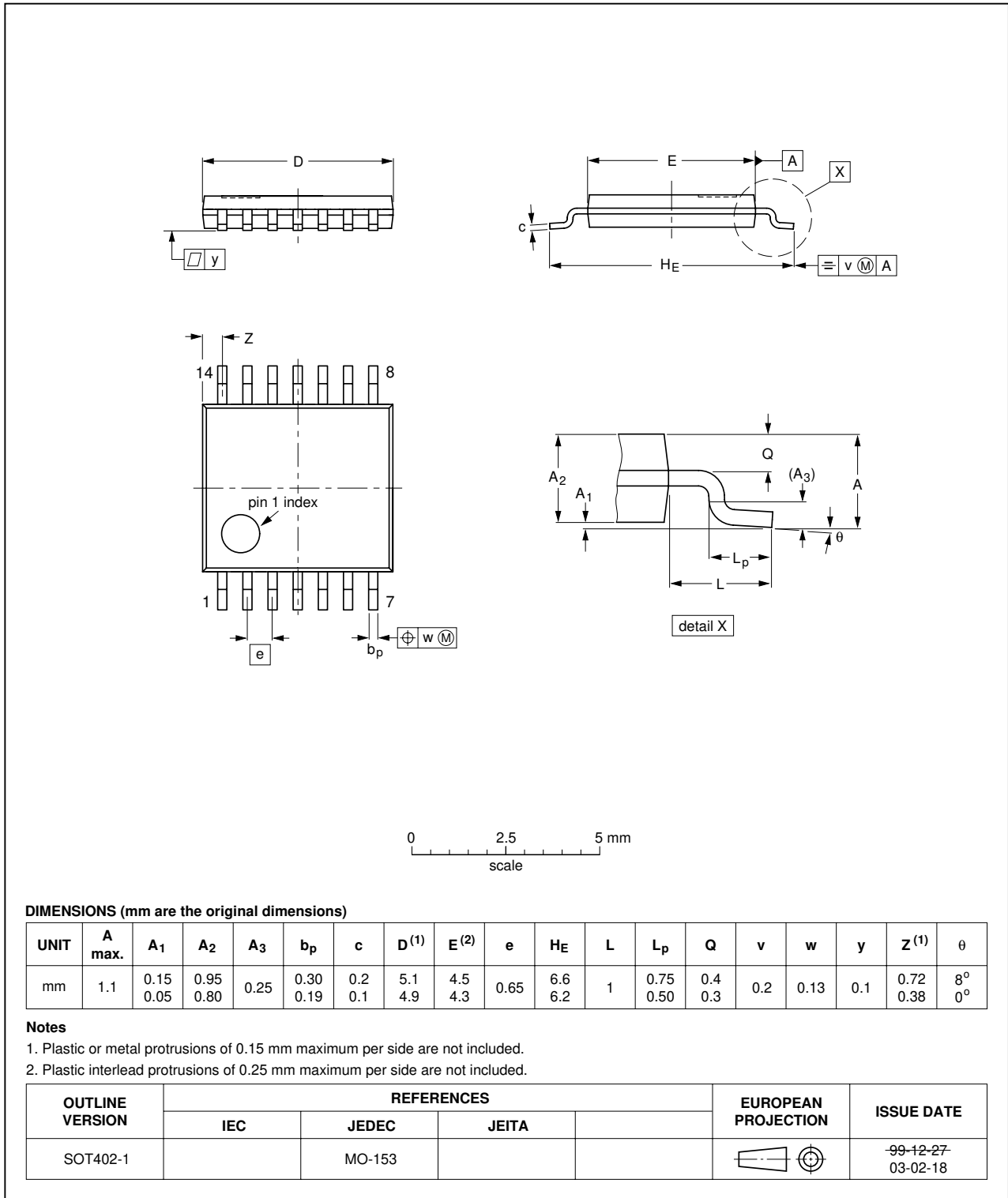

Fig 20. Package outline SOT402-1 (TSSOP14)

13. Soldering of SMD packages

This text provides a very brief insight into a complex technology. A more in-depth account of soldering ICs can be found in Application Note *AN10365 "Surface mount reflow soldering description"*.

13.1 Introduction to soldering

Soldering is one of the most common methods through which packages are attached to Printed Circuit Boards (PCBs), to form electrical circuits. The soldered joint provides both the mechanical and the electrical connection. There is no single soldering method that is ideal for all IC packages. Wave soldering is often preferred when through-hole and Surface Mount Devices (SMDs) are mixed on one printed wiring board; however, it is not suitable for fine pitch SMDs. Reflow soldering is ideal for the small pitches and high densities that come with increased miniaturization.

13.2 Wave and reflow soldering

Wave soldering is a joining technology in which the joints are made by solder coming from a standing wave of liquid solder. The wave soldering process is suitable for the following:

- Through-hole components
- Leaded or leadless SMDs, which are glued to the surface of the printed circuit board

Not all SMDs can be wave soldered. Packages with solder balls, and some leadless packages which have solder lands underneath the body, cannot be wave soldered. Also, leaded SMDs with leads having a pitch smaller than ~0.6 mm cannot be wave soldered, due to an increased probability of bridging.

The reflow soldering process involves applying solder paste to a board, followed by component placement and exposure to a temperature profile. Leaded packages, packages with solder balls, and leadless packages are all reflow solderable.

Key characteristics in both wave and reflow soldering are:

- Board specifications, including the board finish, solder masks and vias
- Package footprints, including solder thieves and orientation
- The moisture sensitivity level of the packages
- Package placement
- Inspection and repair
- Lead-free soldering versus SnPb soldering

13.3 Wave soldering

Key characteristics in wave soldering are:

- Process issues, such as application of adhesive and flux, clinching of leads, board transport, the solder wave parameters, and the time during which components are exposed to the wave
- Solder bath specifications, including temperature and impurities

13.4 Reflow soldering

Key characteristics in reflow soldering are:

- Lead-free versus SnPb soldering; note that a lead-free reflow process usually leads to higher minimum peak temperatures (see [Figure 21](#)) than a SnPb process, thus reducing the process window
- Solder paste printing issues including smearing, release, and adjusting the process window for a mix of large and small components on one board
- Reflow temperature profile; this profile includes preheat, reflow (in which the board is heated to the peak temperature) and cooling down. It is imperative that the peak temperature is high enough for the solder to make reliable solder joints (a solder paste characteristic). In addition, the peak temperature must be low enough that the packages and/or boards are not damaged. The peak temperature of the package depends on package thickness and volume and is classified in accordance with [Table 10](#) and [11](#)

Table 10. SnPb eutectic process (from J-STD-020C)

Package thickness (mm)	Package reflow temperature (°C)	
	Volume (mm ³)	
	< 350	≥ 350
< 2.5	235	220
≥ 2.5	220	220

Table 11. Lead-free process (from J-STD-020C)

Package thickness (mm)	Package reflow temperature (°C)		
	Volume (mm ³)		
	< 350	350 to 2000	> 2000
< 1.6	260	260	260
1.6 to 2.5	260	250	245
> 2.5	250	245	245

Moisture sensitivity precautions, as indicated on the packing, must be respected at all times.

Studies have shown that small packages reach higher temperatures during reflow soldering, see [Figure 21](#).

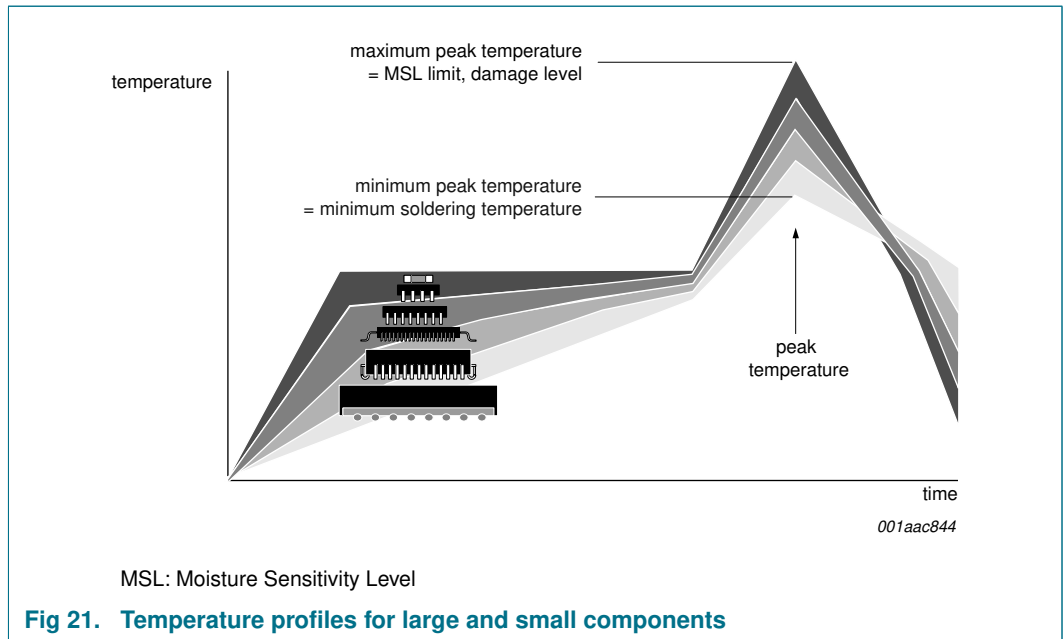

For further information on temperature profiles, refer to Application Note AN10365 “Surface mount reflow soldering description”.

14. Abbreviations

Table 12. Abbreviations

Acronym	Description
CDM	Charged-Device Model
ESD	ElectroStatic Discharge
HBM	Human Body Model
IC	Integrated Circuit
I ² C-bus	Inter-Integrated Circuit bus
LSB	Least Significant Bit
MM	Machine Model
MSB	Most Significant Bit
PCB	Printed-Circuit Board
SMBus	System Management Bus

15. Revision history

Table 13. Revision history

Document ID	Release date	Data sheet status	Change notice	Supersedes
PCA9543A_43B_43C_6	20090615	Product data sheet	-	PCA9543A_43B_43C_5
Modifications:	<ul style="list-style-type: none"> • Table 9 "Dynamic characteristics": <ul style="list-style-type: none"> – Symbol t_f: changed Unit from "μs" to "ns" – Symbol C_b: changed Unit from "μs" to "pF" 			
PCA9543A_43B_43C_5	20081117	Product data sheet	-	PCA9543A_43B_43C_4
PCA9543A_43B_43C_4	20061020	Product data sheet	-	PCA9543A_3
PCA9543A_3 (9397 750 14316)	20050321	Product data sheet	-	PCA9543A_2
PCA9543A_2 (9397 750 13988)	20040929	Objective data sheet	-	PCA9543A_1
PCA9543A_1 (9397 750 13299)	20040728	Objective data sheet	-	-

16. Legal information

16.1 Data sheet status

Document status ^{[1][2]}	Product status ^[3]	Definition
Objective [short] data sheet	Development	This document contains data from the objective specification for product development.
Preliminary [short] data sheet	Qualification	This document contains data from the preliminary specification.
Product [short] data sheet	Production	This document contains the product specification.

[1] Please consult the most recently issued document before initiating or completing a design.

[2] The term 'short data sheet' is explained in section "Definitions".

[3] The product status of device(s) described in this document may have changed since this document was published and may differ in case of multiple devices. The latest product status information is available on the Internet at URL <http://www.nxp.com>.

16.2 Definitions

Draft — The document is a draft version only. The content is still under internal review and subject to formal approval, which may result in modifications or additions. NXP Semiconductors does not give any representations or warranties as to the accuracy or completeness of information included herein and shall have no liability for the consequences of use of such information.

Short data sheet — A short data sheet is an extract from a full data sheet with the same product type number(s) and title. A short data sheet is intended for quick reference only and should not be relied upon to contain detailed and full information. For detailed and full information see the relevant full data sheet, which is available on request via the local NXP Semiconductors sales office. In case of any inconsistency or conflict with the short data sheet, the full data sheet shall prevail.

16.3 Disclaimers

General — Information in this document is believed to be accurate and reliable. However, NXP Semiconductors does not give any representations or warranties, expressed or implied, as to the accuracy or completeness of such information and shall have no liability for the consequences of use of such information.

Right to make changes — NXP Semiconductors reserves the right to make changes to information published in this document, including without limitation specifications and product descriptions, at any time and without notice. This document supersedes and replaces all information supplied prior to the publication hereof.

Suitability for use — NXP Semiconductors products are not designed, authorized or warranted to be suitable for use in medical, military, aircraft, space or life support equipment, nor in applications where failure or malfunction of an NXP Semiconductors product can reasonably be expected to result in personal injury, death or severe property or environmental

damage. NXP Semiconductors accepts no liability for inclusion and/or use of NXP Semiconductors products in such equipment or applications and therefore such inclusion and/or use is at the customer's own risk.

Applications — Applications that are described herein for any of these products are for illustrative purposes only. NXP Semiconductors makes no representation or warranty that such applications will be suitable for the specified use without further testing or modification.

Limiting values — Stress above one or more limiting values (as defined in the Absolute Maximum Ratings System of IEC 60134) may cause permanent damage to the device. Limiting values are stress ratings only and operation of the device at these or any other conditions above those given in the Characteristics sections of this document is not implied. Exposure to limiting values for extended periods may affect device reliability.

Terms and conditions of sale — NXP Semiconductors products are sold subject to the general terms and conditions of commercial sale, as published at <http://www.nxp.com/profile/terms>, including those pertaining to warranty, intellectual property rights infringement and limitation of liability, unless explicitly otherwise agreed to in writing by NXP Semiconductors. In case of any inconsistency or conflict between information in this document and such terms and conditions, the latter will prevail.

No offer to sell or license — Nothing in this document may be interpreted or construed as an offer to sell products that is open for acceptance or the grant, conveyance or implication of any license under any copyrights, patents or other industrial or intellectual property rights.

Export control — This document as well as the item(s) described herein may be subject to export control regulations. Export might require a prior authorization from national authorities.

16.4 Trademarks

Notice: All referenced brands, product names, service names and trademarks are the property of their respective owners.

I²C-bus — logo is a trademark of NXP B.V.

17. Contact information

For more information, please visit: <http://www.nxp.com>

For sales office addresses, please send an email to: salesaddresses@nxp.com

18. Contents

1 General description 1

2 Features 1

3 Ordering information 2

3.1 Ordering options 2

4 Block diagram 3

5 Pinning information 4

5.1 Pinning 4

5.2 Pin description 4

6 Functional description 5

6.1 Device address 5

6.2 Control register 5

6.2.1 Control register definition 6

6.2.2 Interrupt handling 6

6.3 RESET input 7

6.4 Power-on reset 7

6.5 Voltage translation 7

7 Characteristics of the I²C-bus 8

7.1 Bit transfer 8

7.2 START and STOP conditions 8

7.3 System configuration 9

7.4 Acknowledge 9

7.5 Bus transactions 10

8 Application design-in information 11

9 Limiting values 11

10 Static characteristics 12

11 Dynamic characteristics 14

12 Package outline 16

13 Soldering of SMD packages 18

13.1 Introduction to soldering 18

13.2 Wave and reflow soldering 18

13.3 Wave soldering 18

13.4 Reflow soldering 19

14 Abbreviations 20

15 Revision history 21

16 Legal information 22

16.1 Data sheet status 22

16.2 Definitions 22

16.3 Disclaimers 22

16.4 Trademarks 22

17 Contact information 22

18 Contents 23

Please be aware that important notices concerning this document and the product(s) described herein, have been included in section 'Legal information'.



© NXP B.V. 2009.

All rights reserved.

For more information, please visit: <http://www.nxp.com>

For sales office addresses, please send an email to: salesaddresses@nxp.com

Date of release: 15 June 2009

Document identifier: PCA9543A_43B_43C_6