



Chipsmall Limited consists of a professional team with an average of over 10 year of expertise in the distribution of electronic components. Based in Hongkong, we have already established firm and mutual-benefit business relationships with customers from,Europe,America and south Asia,supplying obsolete and hard-to-find components to meet their specific needs.

With the principle of “Quality Parts,Customers Priority,Honest Operation,and Considerate Service”,our business mainly focus on the distribution of electronic components. Line cards we deal with include Microchip,ALPS,ROHM,Xilinx,Pulse,ON,Everlight and Freescale. Main products comprise IC,Modules,Potentiometer,IC Socket,Relay,Connector.Our parts cover such applications as commercial,industrial, and automotives areas.

We are looking forward to setting up business relationship with you and hope to provide you with the best service and solution. Let us make a better world for our industry!



Contact us

Tel: +86-755-8981 8866 Fax: +86-755-8427 6832

Email & Skype: info@chipsmall.com Web: www.chipsmall.com

Address: A1208, Overseas Decoration Building, #122 Zhenhua RD., Futian, Shenzhen, China



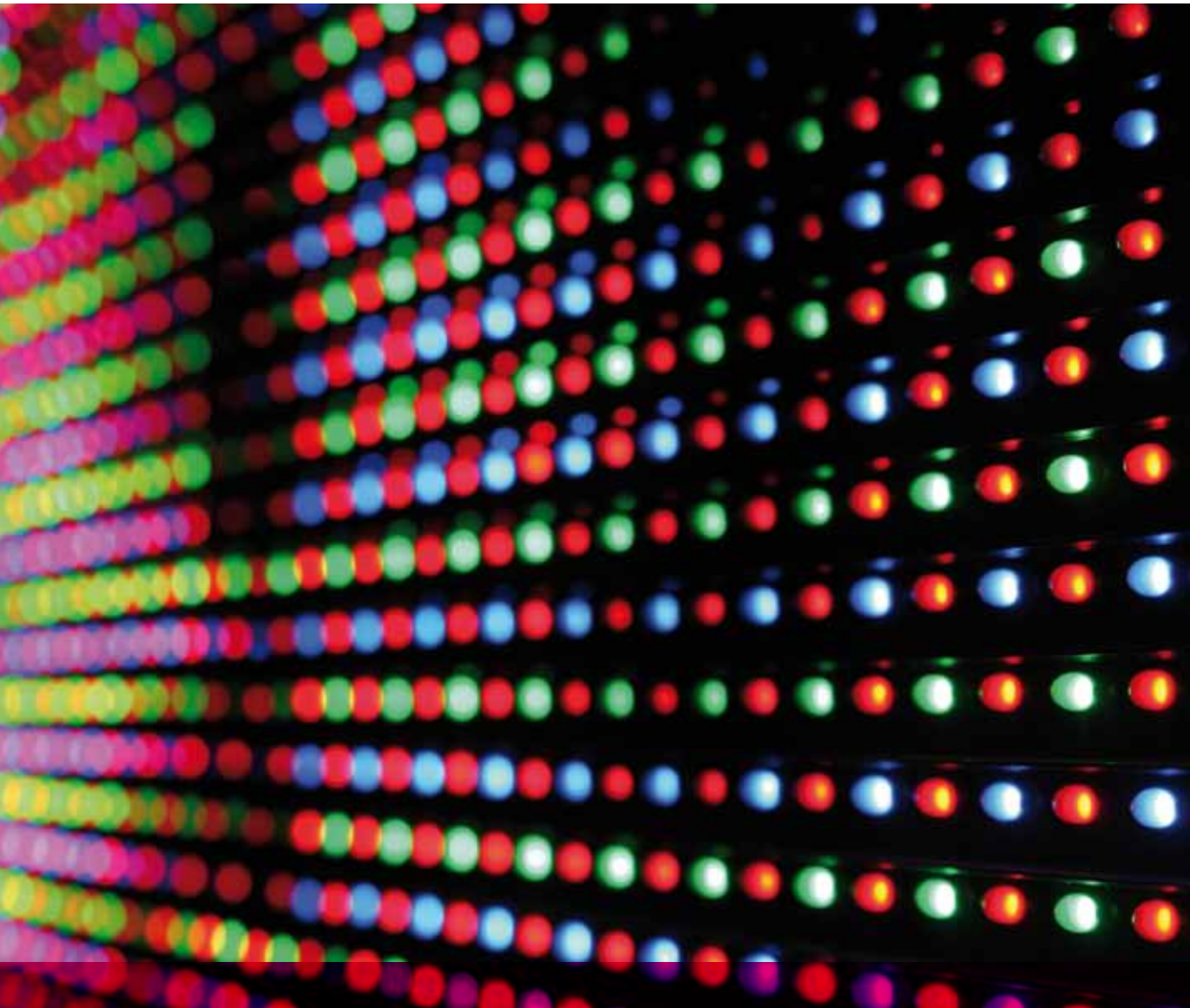

LED controllers

Voltage-switch drivers, constant-current drivers, and Flash LED drivers



LEDs are used in a wide range of applications, from low-end status indicators to high-end video displays. System designers often need the ability to control these LEDs, but can't afford to tie up the system processor to do so. NXP's LED controllers solve this problem, performing a variety of control tasks while offloading the system processor. Having sent instructions to the LED controller, the processor is free to engage in other tasks or go into a low-power state.

NXP's LED controllers offer a variety of features needed in LED-driving applications. Some of these features include:

- ▶ Blinking and dimming capability
- ▶ Pulse-width modulation (PWM) for LED control
- ▶ Color mixing capabilities
- ▶ Fast-mode Plus (Fm+) communication channel with data transfer rate of up to 1 Mbps over the I²C-bus.
- ▶ Different output drive types (push-pull, open-drain voltage switch or constant-current driver)
- ▶ Independent control of LEDs
- ▶ LED status and fault reading
- ▶ Short-circuit protection
- ▶ Over-temperature protection

The devices are classified in three groups: voltage-switch drivers, constant-current drivers, and Flash LED drivers. These groups are discussed below.

Voltage-Switch Drivers

Voltage-switch output driver devices control the LED connected to the output pin by switching the connection to ground or supply on or off. A series resistor connected between the LED and the device limits the current that flows through the LED into the device.

Voltage-switch devices have the advantage of dissipating the heat outside the device, in the series resistor. Therefore the device is insensitive to heat dissipation and is good for driving multiple LEDs in series, with different forward-bias voltages (V_f), from the same supply.

Constant-Current Drivers

A current-regulated LED driver results in the LED light remaining constant with the supply-voltage fluctuations. NXP constant-current LED drivers are used for low-current luminary lighting applications requiring accurate lighting control independent of supply voltage, temperature, and LED forward-bias voltage.

Flash LED Drivers

NXP Flash LED Drivers are high-efficiency, maximum-output, small footprint devices with touch capability and an indicator LED output feature. These devices are highly integrated with hardware and I²C interface modes.

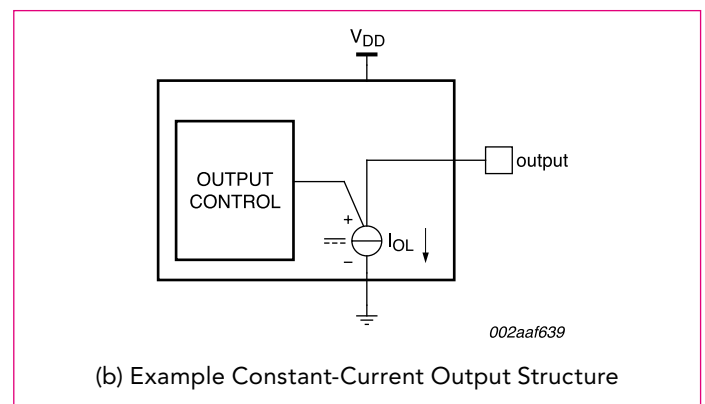
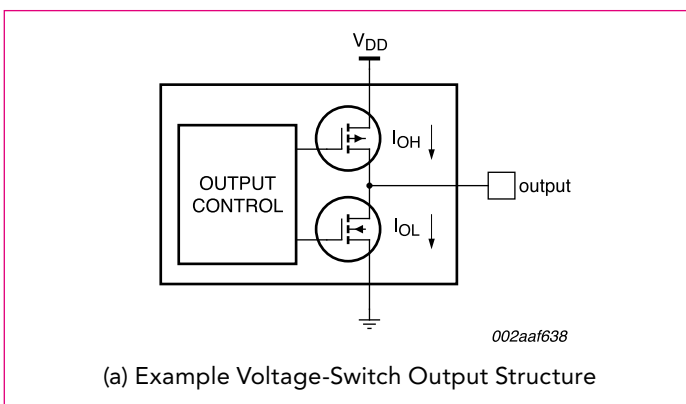

The LED controllers are supported by application boards and daughter cards, an established manufacturing infrastructure that supports high volumes, and several technical documents. NXP helps system designers make lighting affordable, in everything from indoor consumer electronics and appliances to outdoor decorative lighting.

LED Controllers Selection Guide

Device	Function	Number of LED Outputs	Operating Voltage Range	Standby Current [1]	Type of LED Drive	Max LED Drive Current	Max LED Drive Voltage	Output Type	Default POR LED Output State	LED Pin can be used as Input	Number of PWMs	Individual PWM Resolution (Steps)	Group PWM Resolution (Steps)	Individual Brightness Control	Group Brightness Control	Output Enable / PWM Control	Programmable Output Delay	Dimming Capability	Blinking Capability	Pattern Sequencer	LED Error Detection	Thermal Shutdown	Interface	Number of Device Addresses		Internal Oscillator Frequency	Oscillator Calibration	External Oscillator Input	Individual PWM Frequency	Group PWM Frequency	Status
																								Hardware Reset	Software Reset						
PCA9550	Blinker	2	2.3 V - 5.5 V	1.9 mA	Voltage switch	25 mA	5 V	Open Drain	Hi-Z Input	Y	2	256	-	Y	N	N	N	N	Y	N	N	N	PC, Fm	2	Y	330 KHz	-	-	0.172 Hz - 44 Hz	-	In Production
PCA9553	Blinker	4	2.3 V - 5.5 V	1.9 mA	Voltage switch	25 mA	5 V	Open Drain	Hi-Z Input	Y	2	256	-	N	N	N	N	N	Y	N	N	N	PC, Fm	1	N	330 KHz	-	-	0.172 Hz - 44 Hz	-	In Production
PCA9551	Blinker	8	2.3 V - 5.5 V	1.9 mA	Voltage switch	25 mA	5 V	Open Drain	Hi-Z Input	Y	2	256	-	N	N	N	N	N	Y	N	N	N	PC, Fm	8	Y	330 KHz	-	-	0.172 Hz - 44 Hz	-	In Production
PCA9552	Blinker	16	2.3 V - 5.5 V	2.1 mA	Voltage switch	25 mA	5 V	Open Drain	Hi-Z Input	Y	2	256	-	N	N	N	N	N	Y	N	N	N	PC, Fm	8	Y	330 KHz	-	-	0.172 Hz - 44 Hz	-	In Production
PCA9530	Dimmer & Blinker	2	2.3 V - 5.5 V	1.9 mA	Voltage switch	25 mA	5 V	Open Drain	Hi-Z Input	Y	2	256	-	Y	N	N	N	Y	Y	N	N	N	PC, Fm	2	Y	330 KHz	-	-	0.591 Hz - 152 Hz	-	In Production
PCA9533	Dimmer & Blinker	4	2.3 V - 5.5 V	1.9 mA	Voltage switch	25 mA	5 V	Open Drain	Hi-Z Input	Y	2	256	-	N	N	N	N	Y	Y	N	N	N	PC, Fm	2	N	330 KHz	-	-	0.591 Hz - 152 Hz	-	In Production
PCA9531	Dimmer & Blinker	8	2.3 V - 5.5 V	1.9 mA	Voltage switch	25 mA	5 V	Open Drain	Hi-Z Input	Y	2	256	-	N	N	N	N	Y	Y	N	N	N	PC, Fm	8	Y	330 KHz	-	-	0.591 Hz - 152 Hz	-	In Production
PCA9532	Dimmer & Blinker	16	2.3 V - 5.5 V	2.1 mA	Voltage switch	25 mA	5 V	Open Drain	Hi-Z Input	Y	2	256	-	N	N	N	N	Y	Y	N	N	N	PC, Fm	8	Y	330 KHz	-	-	0.591 Hz - 152 Hz	-	In Production
PCA9632	Dimmer & Blinker	4	2.3 V - 5.5 V	0.005 mA	Voltage switch	-10 mA 25 mA	5 V	Push Pull (Configurable)	Hi-Z	N	4 + 1	256 (64)	64 (16)	Y	Y	N	N	Y	Y	N	N	N	PC, Fm+	1, 4	N	400 KHz	N	N	1.56 KHz (6.25 KHz)	190 Hz	In Production
PCA9633	Dimmer & Blinker	4	2.3 V - 5.5 V	3.8 mA	Voltage switch	-10 mA 25 mA	5 V	Push Pull (Configurable)	Push Pull Logic H	N	4 + 1	256	256	Y	Y	Y	N	Y	Y	N	N	N	PC, Fm+	1, 4, 126	N	25 MHz	N	N	97 KHz	190 Hz (97 KHz)	In Production
PCA9634	Dimmer & Blinker	8	2.3 V - 5.5 V	3.8 mA	Voltage switch	-10 mA 25 mA	5 V	Push Pull (Configurable)	Push Pull Logic H	N	8 + 1	256	256	Y	Y	Y	N	Y	Y	N	N	N	PC, Fm+	1, 4, 126	N	25 MHz	N	N	97 KHz (97 KHz)	190 Hz (97 KHz)	In Production
PCA9635	Dimmer & Blinker	16	2.3 V - 5.5 V	3.8 mA	Voltage switch	-10 mA 25 mA	5 V	Push Pull (Configurable)	Push Pull Logic H	N	16 + 1	256	256	Y	Y	Y	N	Y	Y	N	N	N	PC, Fm+	126	N	25 MHz	N	N	97 KHz	190 Hz (97 KHz)	In Production
PCA9685	Dimmer	16	2.3 V - 5.5 V	2.2 mA	Voltage switch	-10 mA 25 mA	5 V	Push Pull (Configurable)	Push Pull Logic L	N	16	4096	-	Y	N	Y	Y	Y	Y	N	N	N	PC, Fm+	126	N	25 MHz	N	Y	40 Hz - 1000 Hz	-	In Production
PCA9624	Dimmer & Blinker	8	2.3 V - 5.5 V	2.1 mA	Voltage switch	100 mA	40 V	Open Drain	Hi-Z	N	8 + 1	256	256	Y	Y	Y	N	Y	Y	N	N	N	PC, Fm+	126	N	25 MHz	N	N	97 KHz	190 Hz (97 KHz)	In Production
PCA9622	Dimmer & Blinker	16	2.3 V - 5.5 V	1.05 mA	Voltage switch	100 mA	40 V	Open Drain	Hi-Z	N	16 + 1	256	256	Y	Y	Y	N	Y	Y	N	N	N	PC, Fm+	126	N	25 MHz	N	N	97 KHz	190 Hz (97 KHz)	In Production
PCA9626	Dimmer & Blinker	24	2.3 V - 5.5 V	6.0 mA	Voltage switch	100 mA	40 V	Open Drain	Hi-Z	N	24 + 1	256	256	Y	Y	Y	N	Y	Y	N	N	N	PC, Fm+	126	N	25 MHz	N	N	97 KHz	190 Hz (97 KHz)	In Production
PCA9901	Blinker	1	2.1 V - 5.5 V	0.3 mA	Constant Current (Source)	1 to 20 mA	5 V	Open Drain (Source)	Hi-Z	N	0	4096	-	N	N	N	N	N	Y	Y	Y	Y	1-Wire	1	N	18 KHz	N	N	N	N	In Production
PCA9922	Signage	8	3.3 V - 5.5 V	3.2 mA	Constant Current	15 to 60 mA	5 V	Open Drain (Sink)	Hi-Z	N	0	-	-	N	N	Y	N	N	N	N	Y	Y	SPI, 25 MHz	-	N	-	-	-	N	N	In Production
PCA9952	Dimmer & Blinker	16	3.0 V - 5.5 V	500 mA	Constant Current	50 mA	34 V	Open Drain (Sink)	Hi-Z	N	16 + 1	256	256	Y	Y	Y	Y	Y	Y	N	Y	Y	PC, Fm+	8, 4	Y	8 MHz	Y	N	31.5 KHz	122 Hz	In Development
PCA9955	Dimmer & Blinker	16	3.0 V - 5.5 V	500 mA	Constant Current	50 mA	34 V	Open Drain (Sink)	Hi-Z	N	16 + 1	256	256	Y	Y	N	Y	Y	Y	N	Y	Y	PC, Fm+	16, 4	Y	8 MHz	Y	N	31.5 KHz	122 Hz	In Development

[1] Typical value, measured with $V_{DD} = 5.5 V$, no load, $V_L = V_{DD}$ or V_{SS} and $F_{SCL} = 0 KHz$.

LED Flash Drivers Selection Guide

Device	Function	Operating Voltage Range	Flash LED Output Drive Type	Flash LEDs Driven in Series	Maximum LED Drive Current				Fixed Switching Frequency	Integrated Diodes and Resistors	Inductor Broken Coil Detect	Interface Type	Number of Device Addresses	Max Timed Flash Operation	Assist Light	Status
					Flash (1 LED)	Flash (2 LEDs)	Touch	Indicator Output								
SSL3250A	Asynchronous boost converter	2.7 V - 5.5 V	Low-side drive	1 or 2	500 mA	500 mA	200 mA	20 mA	1.2 MHz	N	N	PC, Fm or direct	1	820 ms	N	In Production
SSL3252	Synchronous boost converter	2.5 V - 5.5 V	High-side drive	1 or 2	500 mA	400 mA	160 mA	10 mA	2.0 MHz	Y	Y	PC, Fm or direct	1	820 ms	Y	In Development

PCA9622 Application Example

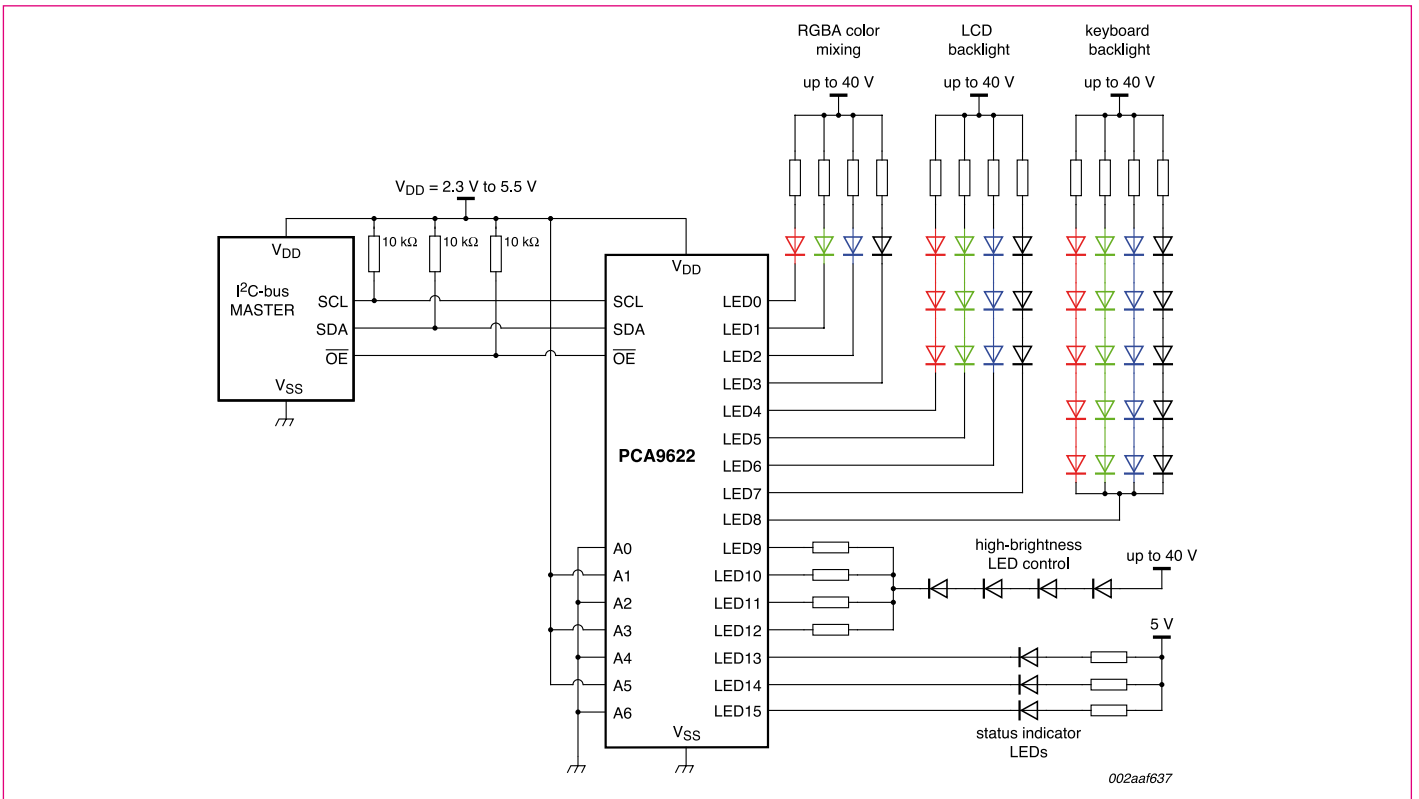

Architectural Lighting



Mobile Phone Application Example



Car Radio Backlight



Application Support

For added application support, NXP offers the following application reports on the LED driver family devices:

- ▶ AN10579: Driving LED light bars using NXP Solutions
http://www.nxp.com/documents/application_note/AN10579.pdf
- ▶ AN10733: Flash LED App. Note
http://www.nxp.com/documents/application_note/AN10733.pdf
- ▶ AN264: I²C Devices for LED Display Control App. Note
http://www.nxp.com/documents/application_note/AN264.pdf
- ▶ AN10315: LED Dimmer Board
http://www.nxp.com/documents/application_note/AN10315.pdf

For more information, visit <http://ics.nxp.com/products/led.drivers/>

NXP offers evaluation modules and demo boards that can be used to develop software and evaluate the performance of the LED controllers and LED Flash drivers.

OM6275 – I²C 2005-1 Evaluation Board

Easy experimentation and training module. I²C-bus connects to LED controllers, other I²C peripherals, and daughter cards. USB Connection. GUI interface allows direct control of device without programming.



OM6276 – PCA9633 Demo Board

Evaluate LED dimming and blinking features of the PCA9633 4-bit (RGBA) PWM LED driver. RJ-45 jack allows series connection to multiple boards to evaluate long-distance Fm+ bus and P82B96.



OM6279 – LED Dimmer Demo Board

NXP LED controllers and GPIO in simulated mobile phone application showing RGB LED color mixing, LED blinking and dimming, and backlight LED control applications.



OM6281 – PCA9698 Daughter Card for I²C 2005-1

PCA9698 40-bit GPIO with easy access to all 40 I/O pins and several LEDs. Demonstrates using PCA9530 2-bit LED dimmer to dim and/or blink all 40 outputs using the /OE input of the PCA9698.



OM6282 – PCA9633 Daughter Card for I²C 2005-1

Demonstrates LED blinking, dimming, and RGBA color mixing using PCA9633 with individual 256-step PWM per channel and global 256-step PWM. Select any of the 64 I²C addresses with the on-board DIP switch.



LED Flash Driver Demo Board

Provides access to the reset, flash, touch and brightness controls of the SSL3250A. The board also has a USB port and GUI software that can be used to control the SSL3250A.



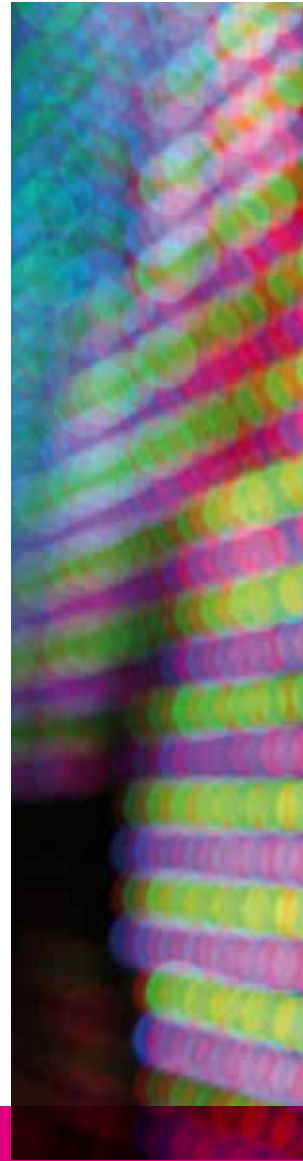

www.nxp.com/interface

©2010 NXP B.V.

All rights reserved. Reproduction in whole or in part is prohibited without the prior written consent of the copyright owner. The information presented in this document does not form part of any quotation or contract, is believed to be accurate and reliable and may be changed without notice. No liability will be accepted by the publisher for any consequence of its use. Publication thereof does not convey nor imply any license under patent- or other industrial or intellectual property rights.

Date of release: June 2010

Document order number: 9397 750 16950

Printed in the Netherlands