



Chipsmall Limited consists of a professional team with an average of over 10 year of expertise in the distribution of electronic components. Based in Hongkong, we have already established firm and mutual-benefit business relationships with customers from,Europe,America and south Asia,supplying obsolete and hard-to-find components to meet their specific needs.

With the principle of “Quality Parts,Customers Priority,Honest Operation,and Considerate Service”,our business mainly focus on the distribution of electronic components. Line cards we deal with include Microchip,ALPS,ROHM,Xilinx,Pulse,ON,Everlight and Freescale. Main products comprise IC,Modules,Potentiometer,IC Socket,Relay,Connector.Our parts cover such applications as commercial,industrial, and automotives areas.

We are looking forward to setting up business relationship with you and hope to provide you with the best service and solution. Let us make a better world for our industry!



Contact us

Tel: +86-755-8981 8866 Fax: +86-755-8427 6832

Email & Skype: info@chipsmall.com Web: www.chipsmall.com

Address: A1208, Overseas Decoration Building, #122 Zhenhua RD., Futian, Shenzhen, China





PCA9571

Remote 8-bit general purpose outputs for 1 MHz I²C-bus

Rev. 2 — 21 September 2018

Product data sheet

1. General description

The PCA9571 is a CMOS device that provide 8 bits of General Purpose parallel Output (GPO) expansion in low voltage processor and handheld battery powered mobile applications. They operate at 1 MHz I²C-bus speeds on a lightly loaded bus (<100 pF) while maintaining backward compatibility to Fast-mode (400 kHz) and Standard-mode (100 kHz).

The PCA9571 is a streamlined GPO that consists of 8-bit push-pull outputs that offer low current consumption, small packaging options and a low operating voltage range of 1.1 V to 3.6 V. The latched outputs are symmetrical 4 mA current drive capability at 3.3 V to drive various control logic. The PCA9571 output expanders provide a simple solution when additional outputs are needed while keeping interconnections and floor space to a minimum, for example, in battery powered mobile applications where PCBs are crowded for interfacing to sensors, push buttons, etc.

The PCA9571 contains an internal Power-On Reset (POR) and a Software Reset feature that initializes the device to its default state.

2. Features and benefits

- 1 MHz I²C-bus interface with 6 mA SDA sink capability for lightly loaded buses (<100 pF) and improved power consumption
- Compliant with the I²C-bus Fast and Standard modes
- 1.1 V to 3.6 V operation
- Latched outputs with a sink/source capability of 4 mA at 3.3 V
- Readable device ID (manufacturer, device type, and revision)
- Software Reset
- Power-On Reset
- Low standby current
- -40 °C to +85 °C operation
- ESD protection exceeds 2000 V HBM per JESD22-A114 and 1000 V CDM per JESD22-C101
- Latch-up testing is done to JEDEC standard JESD78 which exceeds 100 mA
- Package offered: XQFN12

3. Applications

- Smartphones and tablets
- Portable medical equipment
- Portable instrumentation and test measurement



4. Ordering information

Table 1. Ordering information

Type number	Topside mark	Package		Version
		Name	Description	
PCA9571GU	71	XQFN12	plastic, extremely thin quad flat package; no leads; 12 terminals; body 1.70 × 2.00 × 0.50 mm	SOT1174-1

4.1 Ordering options

Table 2. Ordering options

Type number	Orderable part number	Package	Packing method	Minimum order quantity	Temperature
PCA9571GU	PCA9571GUX	XQFN12	Reel 7" Q1/T1 *standard mark SMD	4000	T _{amb} = -40 °C to +85 °C

5. Block diagram

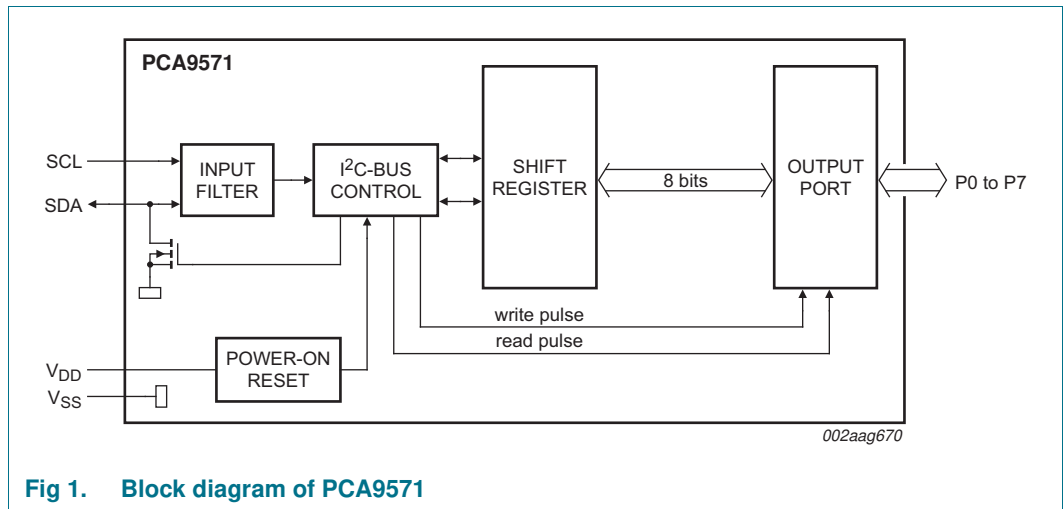
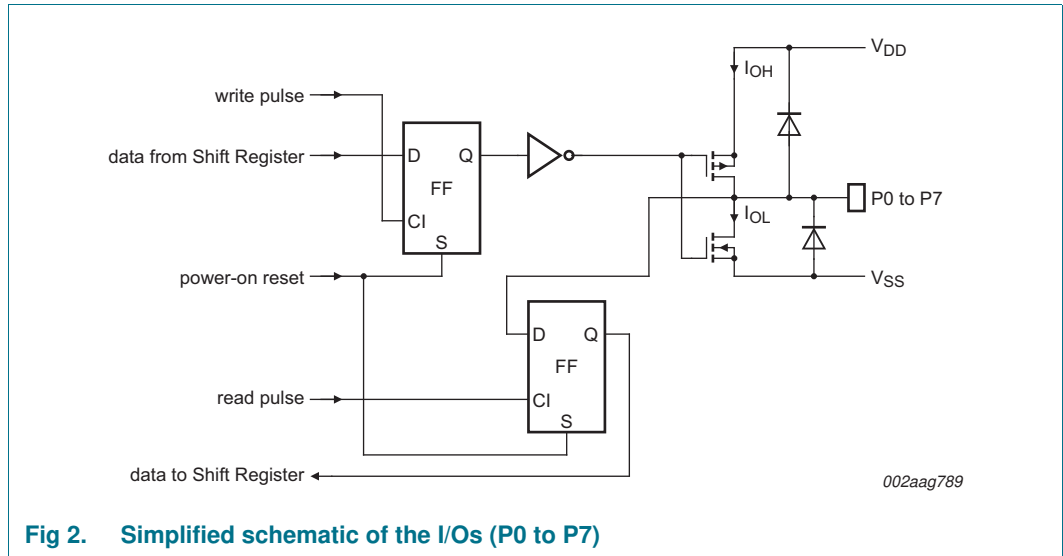
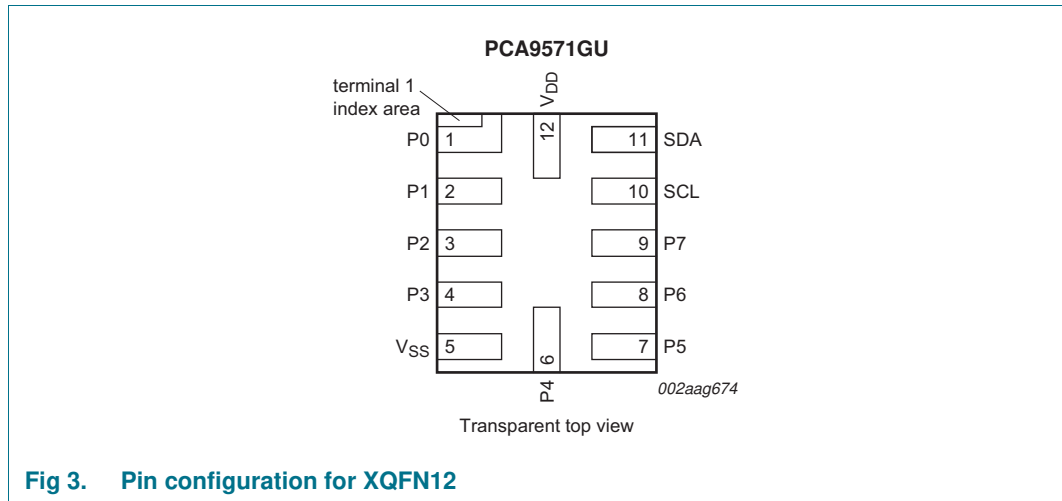

Fig 1. Block diagram of PCA9571



6. Pinning information

6.1 Pinning



6.2 Pin description

Table 3. Pin description

Symbol	Pin	Description
P0	1	output 0
P1	2	output 1
P2	3	output 2
P3	4	output 3
V _{SS}	5	supply ground
P4	6	output 4
P5	7	output 5
P6	8	output 6
P7	9	output 7
SCL	10	serial clock line
SDA	11	serial data line
V _{DD}	12	supply voltage

7. Functional description

Refer to [Figure 1 “Block diagram of PCA9571”](#).

7.1 Device address

Following a START condition, the bus master must send the address of the slave it is accessing and the operation it wants to perform (read or write). The address of the PCA9571 is 4Ah as shown in [Figure 4](#).

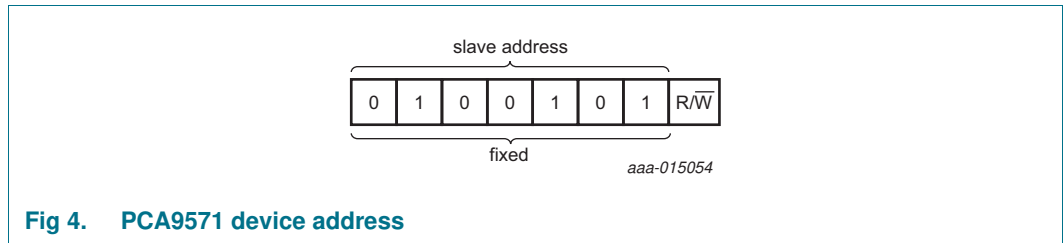

Fig 4. PCA9571 device address

7.2 Software Reset Call, and device ID addresses

Two other different addresses can be sent to the device.

- General Call address: allows to reset the device through the I²C-bus upon reception of the right I²C-bus sequence. See [Section 7.2.1 “Software Reset”](#) for more information.
- Device ID address: allows to read ID information from the device (manufacturer, part identification, revision). See [Section 7.2.2 “Device ID \(PCA9571 ID field\)”](#) for more information.

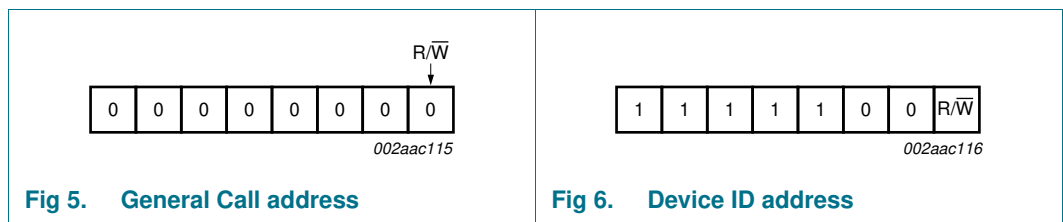

Fig 5. General Call address

Fig 6. Device ID address

7.2.1 Software Reset

The Software Reset Call allows all the devices in the I²C-bus to be reset to the power-up state value through a specific formatted I²C-bus command. To be performed correctly, it implies that the I²C-bus is functional and that there is no device hanging the bus.

The Software Reset sequence is defined as following:

1. A START command is sent by the I²C-bus master.
2. The reserved General Call I²C-bus address '0000 000' with the R/W bit set to 0 (write) is sent by the I²C-bus master.
3. The device acknowledges after seeing the General Call address '0000 0000' (00h) only. If the R/W bit is set to 1 (read), no acknowledge is returned to the I²C-bus master.

4. Once the General Call address has been sent and acknowledged, the master sends 1 byte. The value of the byte must be equal to 06h.
 - a. The device acknowledges this value only. If the byte is not equal to 06h, the device does not acknowledge it.

If more than 1 byte of data is sent, the device does not acknowledge any more.

5. Once the right byte has been sent and correctly acknowledged, the master sends a STOP command to end the Software Reset sequence: the device then resets to the default value (power-up value) and is ready to be addressed again within the specified bus free time. If the master sends a Repeated START instead, no reset is performed.

The I²C-bus master must interpret a non-acknowledge from the device (at any time) as a 'Software Reset Abort'. The device does not initiate a reset of its registers.

The unique sequence that initiates a Software Reset is described in [Figure 7](#).

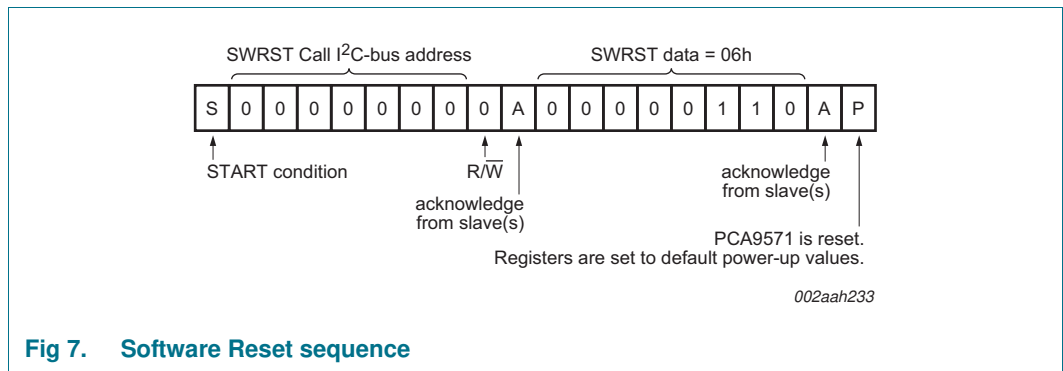

7.2.2 Device ID (PCA9571 ID field)

The Device ID field is a 3-byte read-only (24 bits) word giving the following information:

- 12 bits with the manufacturer name, unique per manufacturer (for example, NXP).
- 9 bits with the part identification, assigned by manufacturer, the 7 MSBs with the category ID and the 6 LSBs with the feature ID (for example PCA9571 8-bit I/O expander).
- 3 bits with the die revision, assigned by manufacturer (for example, Rev X).

The Device ID is read-only, hardwired in the device and can be accessed as follows:

1. START command
2. The master sends the Reserved Device ID I²C-bus address followed by the R/W bit set to 0 (write): '1111 1000'.
3. The master sends the I²C-bus slave address of the slave device it needs to identify. The LSB is a 'Don't care' value. Only one device must acknowledge this byte (the one that has the I²C-bus slave address).
4. The master sends a Re-START command.

Remark: A STOP command followed by a START command will reset the slave state machine and the Device ID read cannot be performed. Also, a STOP command or a Re-START command followed by an access to another slave device will reset the slave state machine and the Device ID Read cannot be performed.

5. The master sends the Reserved Device ID I²C-bus address followed by the R/W bit set to 1 (read): '1111 1001'.
6. The Device ID Read can be done, starting with the 12 manufacturer bits (first byte + 4 MSB of the second byte), followed by the 9 part identification bits (4 LSBs of the second byte + 5 MSBs of the third byte), and then the 3 die revision bits (3 LSBs of the third byte).
7. The master ends the reading sequence by NACKing the last byte, thus resetting the slave device state machine and allowing the master to send the STOP command.

Remark: The reading of the Device ID can be stopped anytime by sending a NACK command.

If the master continues to ACK the bytes after the third byte, the slave rolls back to the first byte and keeps sending the Device ID sequence until a NACK has been detected.

PCA9571 Device ID is shown in [Figure 8](#).

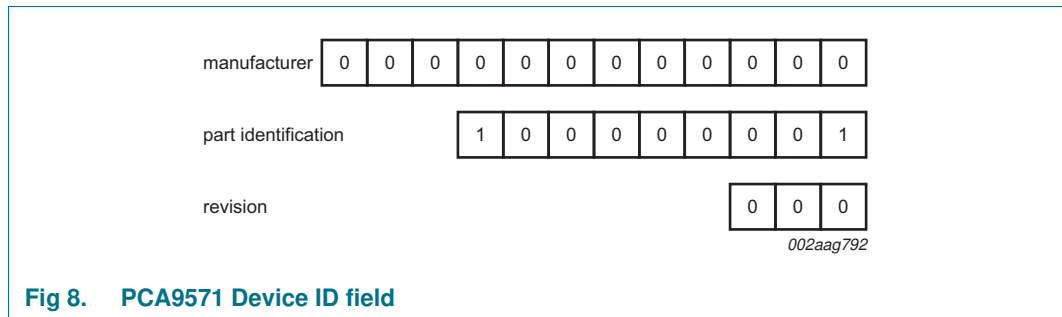
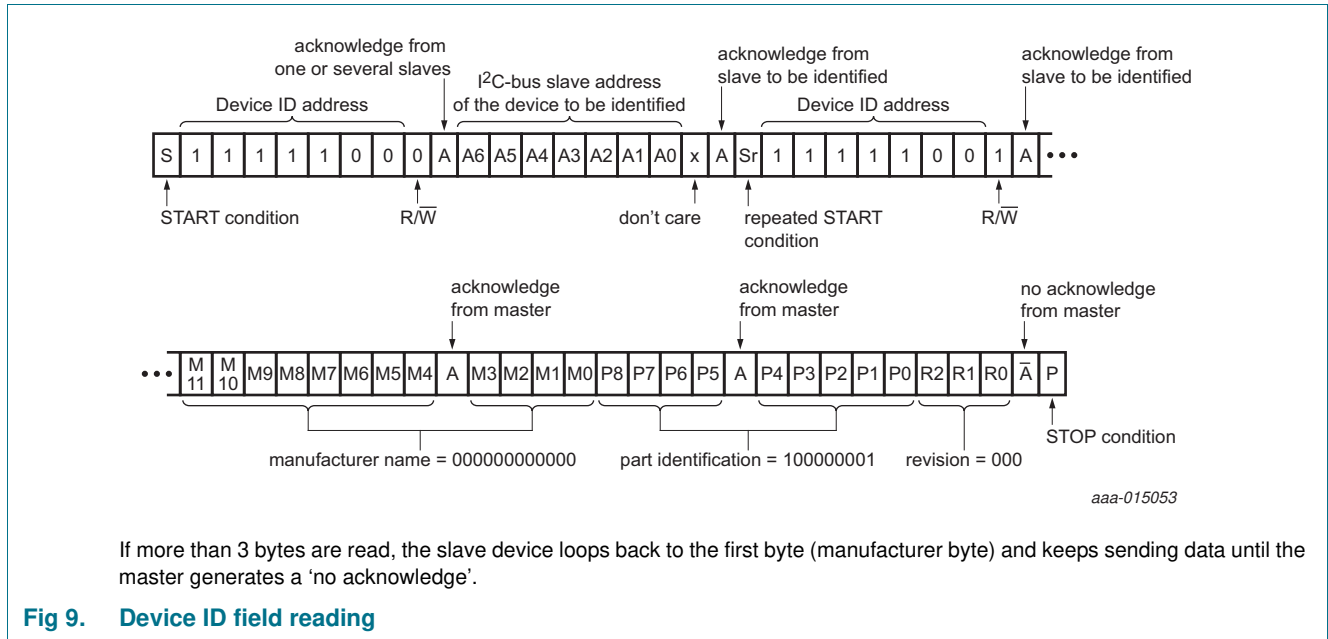

Fig 8. PCA9571 Device ID field



8. I/O programming

8.1 I/O architecture

The device's ports (see [Figure 2](#)) are entirely independent and are output ports. The state of the ports at the pin is transferred from the ports to the microcontroller in the Read mode (see [Figure 11](#)). Output data is transmitted to the ports in the Write mode (see [Figure 10](#)).

At power-on or after reset, all ports are HIGH. The state of the Output Port register determines if either Q1 or Q2 is on, driving the line either HIGH or LOW. A bit set to 1 in the data byte will drive the line HIGH at the corresponding port. A bit set to 0 in the data byte will drive the line LOW at the corresponding port.

If an external voltage is applied to an output, care should be exercised because of the low-impedance path that exists between the pin and either V_{DD} or V_{SS}.

8.2 Writing to the port (Output mode)

To write, the master (microcontroller) first addresses the slave device. By setting the last bit of the byte containing the slave address to logic 0 the Write mode is entered. The device acknowledges and the master sends the data byte for P7 to P0 and is acknowledged by the device. The 8-bit data is presented on the port lines after it has been acknowledged by the device. The number of data bytes that can be sent successively is not limited. The previous data is overwritten every time a data byte has been sent.

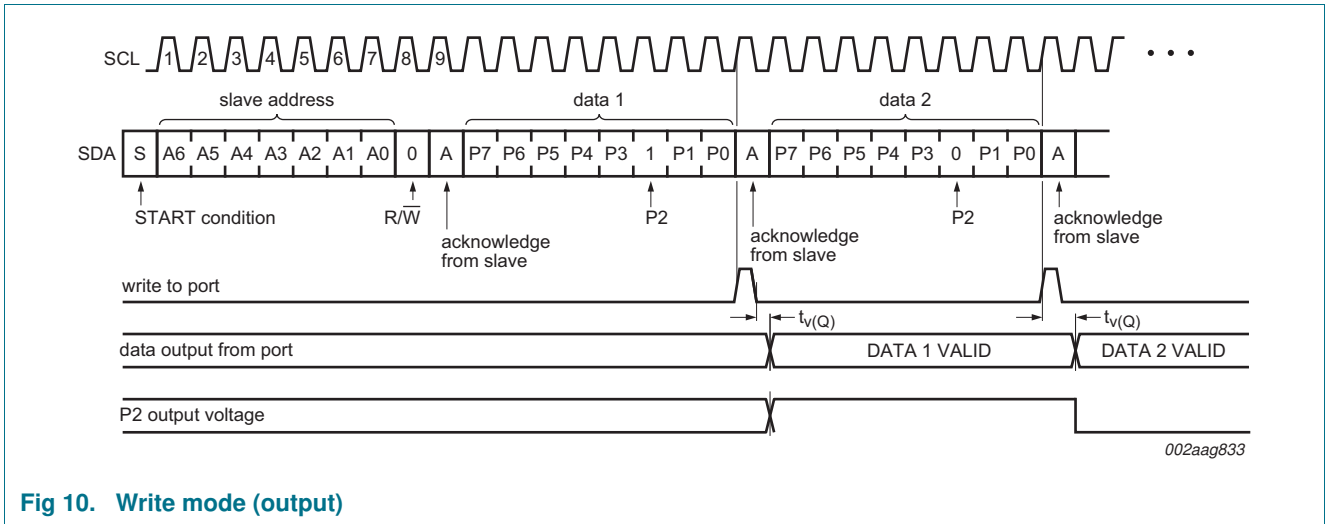

Fig 10. Write mode (output)

8.3 Reading from a port (Input mode)

All ports are outputs and cannot be used as inputs. When reading the device, the data returned is the port state at the pin. To read, the master (microcontroller) first addresses the slave device by setting the last bit of the byte containing the slave address to logic 1. The data byte that follows on the SDA is the value of the ports pins. There is no limit to the number of bytes read, and the state of the output port pins is updated at each acknowledge cycle. Logic 1 means that the port is HIGH. Logic 0 means that the port is LOW.

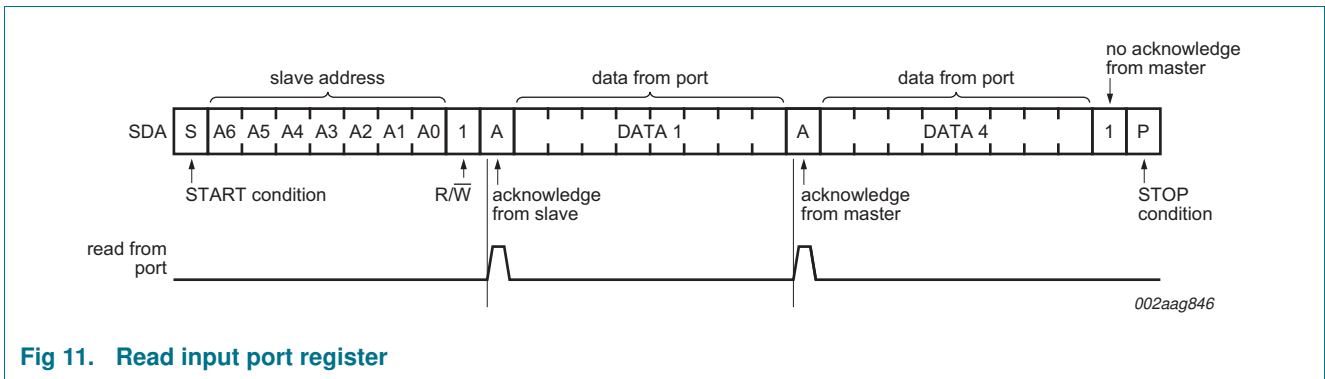

Fig 11. Read input port register

8.4 Power-on reset

When power is applied to V_{DD} , an internal Power-On Reset (POR) holds the device in a reset condition until V_{DD} has reached V_{POR} . At that point, the reset condition is released and the device registers and I²C-bus/SMBus state machine will initialize to their power-on output HIGH states. See [Section 13](#) for DC and AC characteristics of the POR function.

9. Application design-in information

9.1 I/O expander applications

Figure 12 shows an 8-bit output expander application. The desired HIGH or LOW logic levels are controlled by the master with speeds of up to 1 MHz on a lightly loaded bus (<100 pF). This allows the host processor to control various functions quickly and with very low overhead. The port read function of the device enables the host processor to poll the status of the output port pins. This is useful for system recovery operations or debugging.

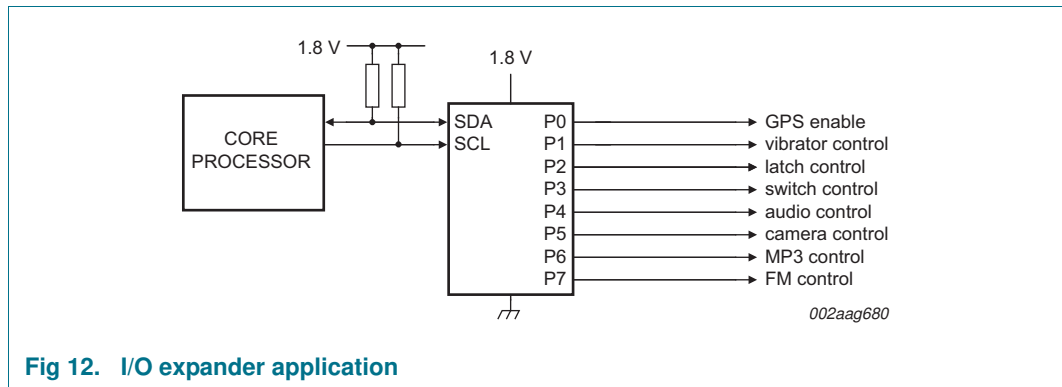

Fig 12. I/O expander application

10. Limiting values

Table 4. Limiting values

In accordance with the Absolute Maximum Rating System (IEC 60134).

Symbol	Parameter	Conditions	Min	Max	Unit
V _{DD}	supply voltage		-0.5	+4	V
V _I	input voltage	SCL; SDA [1]	-0.5	+4	V
I _{IK}	input clamping current	SCL; V _I < 0 V	-	±18	mA
I _{OK}	output clamping current	P port; V _O < 0 V or V _O > V _{DD}	-	±18	mA
		SDA; V _O < 0 V or V _O > V _{DD}	-	±18	mA
I _O	output current	continuous; P port	-	±25	mA
I _{OL}	LOW-level output current	continuous; SDA; V _O = 0 V to V _{DD}	-	25	mA
I _{DD}	supply current	continuous through V _{SS}	-	100	mA
T _{stg}	storage temperature		-65	+150	°C
T _j	junction temperature		-	125	°C

[1] The input negative-voltage and output voltage ratings may be exceeded if the input and output current ratings are observed.

11. Static characteristics

Table 5. Static characteristics

$T_{amb} = -40\text{ °C to }+85\text{ °C}$; $V_{DD} = 1.1\text{ V to }3.6\text{ V}$; unless otherwise specified.

Symbol	Parameter	Conditions	Min	Typ ^[1]	Max	Unit
V_{IK}	input clamping voltage	$I_I = -18\text{ mA}$	-1.2	-	-	V
V_{DD}	supply voltage		1.1	-	3.6	V
V_{POR}	power-on reset voltage	$V_I = V_{DD}$ or V_{SS} ; $I_O = 0\text{ mA}$	-	0.7	1.0	V
V_{OL}	LOW-level output voltage	P port; $I_{OL} = 2\text{ mA}$; $V_{DD} = 1.65\text{ V}$	-	-	0.25	V
		P port; $I_{OL} = 3\text{ mA}$; $V_{DD} = 2.3\text{ V}$	-	-	0.25	V
		P port; $I_{OL} = 4\text{ mA}$; $V_{DD} = 3\text{ V}$	-	-	0.25	V
V_{OH}	HIGH-level output voltage	P port; $I_{OL} = 2\text{ mA}$; $V_{DD} = 1.65\text{ V}$	1.35	-	-	V
		P port; $I_{OL} = 3\text{ mA}$; $V_{DD} = 2.3\text{ V}$	2.0	-	-	V
		P port; $I_{OL} = 4\text{ mA}$; $V_{DD} = 3\text{ V}$	2.7	-	-	V
I_{OL}	LOW-level output current	SDA; $V_{OL} = 0.4\text{ V}$; $V_{DD} = 2.1\text{ V to }3.6\text{ V}$	3	-	-	mA
		SDA; $V_{OL} = 0.2 \times V_{DD}$; $V_{DD} = 1.1\text{ V to }2.0\text{ V}$	1	-	-	mA
V_{IH}	HIGH-level input voltage	SCL, SDA; $V_{DD} = 1.1\text{ V to }1.2\text{ V}$	$0.8 \times V_{DD}$	-	1.2	V
		SCL, SDA; $V_{DD} = 1.2\text{ V to }3.6\text{ V}$	$0.7 \times V_{DD}$	-	3.6	V
V_{IL}	LOW-level input voltage	SCL, SDA; $V_{DD} = 1.1\text{ V to }1.2\text{ V}$	-0.5	-	$0.2 \times V_{DD}$	V
		SCL, SDA; $V_{DD} = 1.2\text{ V to }3.6\text{ V}$	-0.5	-	$0.3 \times V_{DD}$	V
I_I	input current	SCL, SDA; $V_{DD} = 1.1\text{ V to }3.6\text{ V}$; $V_I = V_{DD}$ or V_{SS}	-	-	± 1	μA
I_{DD}	supply current	SDA, P port; V_I on SDA = V_{DD} or V_{SS} ; $I_O = 0\text{ mA}$; $f_{SCL} = 400\text{ kHz}$				
		$V_{DD} = 2.3\text{ V to }3.6\text{ V}$	-	6.5	15	μA
		$V_{DD} = 1.1\text{ V to }2.3\text{ V}$	-	4	9	μA
		SCL, SDA, P port; V_I on SCL, SDA = V_{DD} or V_{SS} ; $I_O = 0\text{ mA}$; $f_{SCL} = 0\text{ kHz}$				
		$V_{DD} = 2.3\text{ V to }3.6\text{ V}$	-	1	3.2	μA
		$V_{DD} = 1.1\text{ V to }2.3\text{ V}$	-	0.6	1.7	μA
		Active mode: SCL, SDA, P port; $I_O = 0\text{ mA}$; $f_{SCL} = 400\text{ kHz}$; continuous register read				
$V_{DD} = 1.1\text{ V to }3.6\text{ V}$	-	50	75	μA		
C_i	input capacitance	$V_I = V_{DD}$ or V_{SS}	-	6	7	pF
C_o	output capacitance	$V_O = V_{DD}$ or V_{SS}	-	3	5	pF
T_{amb}	ambient temperature	operating in free air	-40	-	+85	$^{\circ}\text{C}$

[1] The typical values are at $V_{DD} = 2.2\text{ V}$ and $T_{amb} = 25\text{ °C}$.

11.1 Typical characteristics

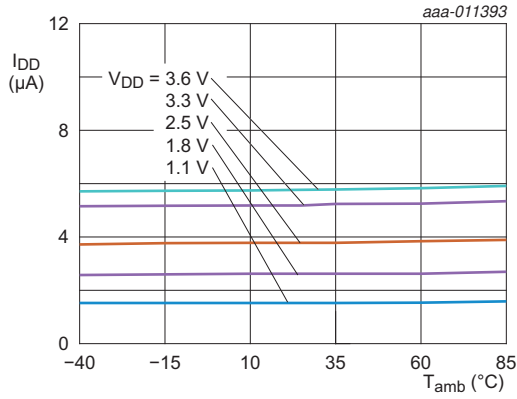

Fig 13. Supply current versus ambient temperature

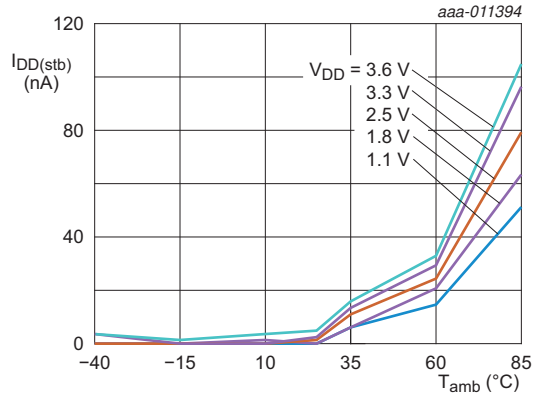
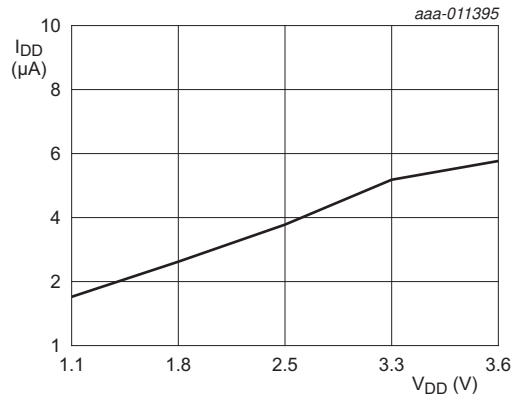
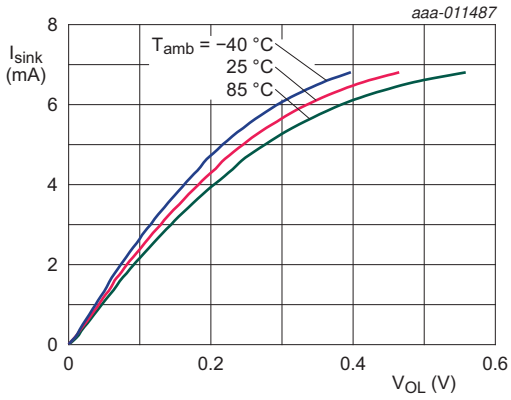

Fig 14. Standby supply current versus ambient temperature



$T_{amb} = 25$ °C

Fig 15. Supply current versus supply voltage



a. $V_{DD} = 1.2\text{ V}$

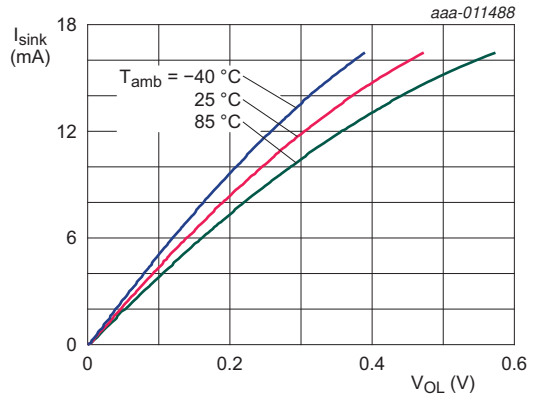

b. $V_{DD} = 1.8\text{ V}$

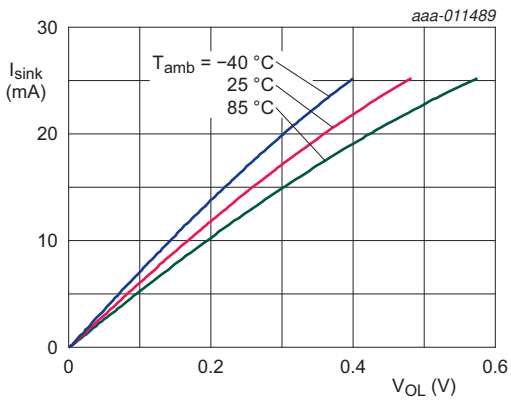

c. $V_{DD} = 2.5\text{ V}$

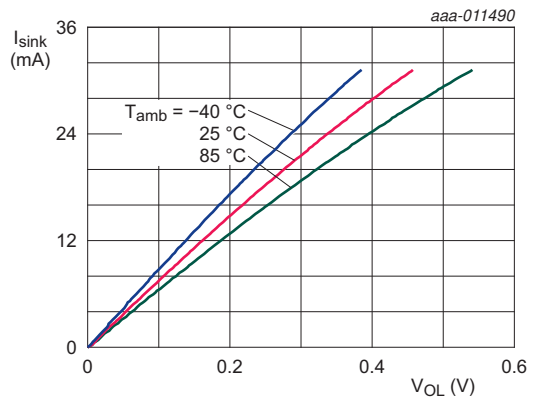

d. $V_{DD} = 3.3\text{ V}$

Fig 16. I/O sink current versus LOW-level output voltage

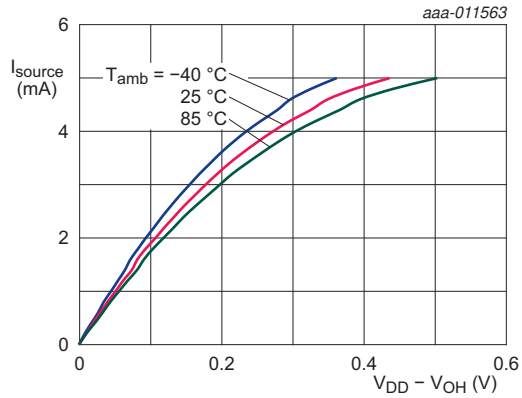

a. $V_{DD} = 1.2\text{ V}$

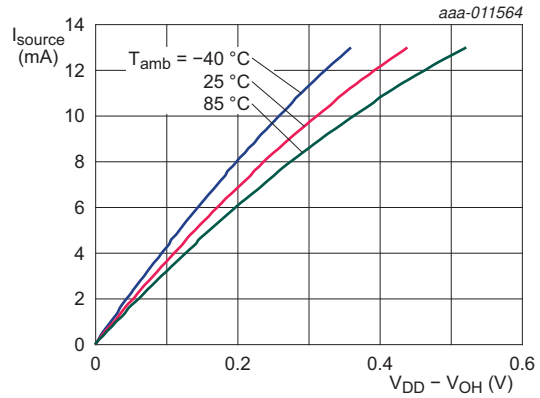

b. $V_{DD} = 1.8\text{ V}$

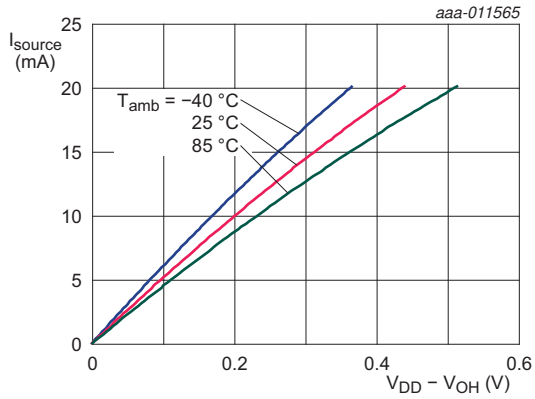

c. $V_{DD} = 2.5\text{ V}$

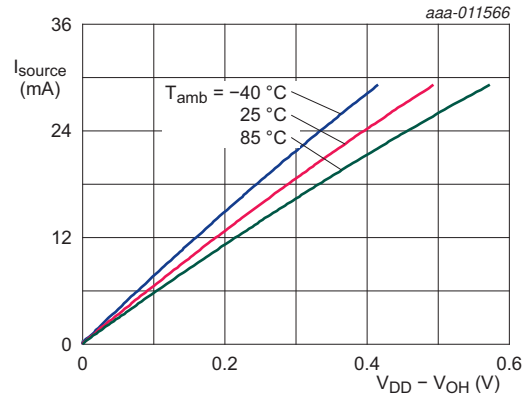

d. $V_{DD} = 3.3\text{ V}$

Fig 17. I/O source current versus HIGH-level output voltage

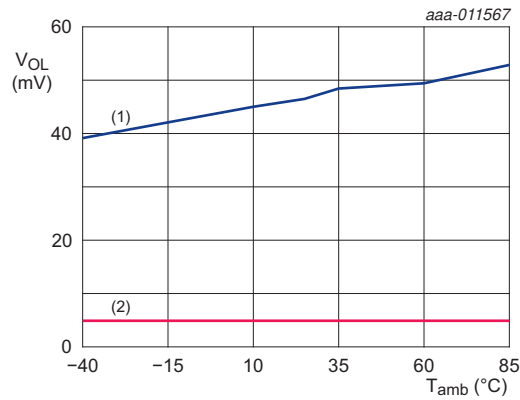

- (1) $V_{DD} = 1.8\text{ V}; I_{\text{sink}} = 2\text{ mA}$
- (2) $V_{DD} = 1.8\text{ V}; I_{\text{sink}} = 100\text{ }\mu\text{A}$

Fig 18. LOW-level output voltage versus temperature

12. Dynamic characteristics

Table 6. Dynamic characteristics

$V_{DD} = 1.1\text{ V to }3.6\text{ V}$; $V_{SS} = 0\text{ V}$; $T_{amb} = -40\text{ }^{\circ}\text{C to }+85\text{ }^{\circ}\text{C}$; unless otherwise specified.

Symbol	Parameter	Conditions	Standard mode I ² C-bus		Fast mode I ² C-bus		1 MHz I ² C-bus ^[1]		Unit
			Min	Max	Min	Max	Min	Max	
f _{SCL}	SCL clock frequency		0	100	0	400	0	1000	kHz
t _{BUF}	bus free time between a STOP and START condition		4.7	-	1.3	-	0.5	-	μs
t _{HD;STA}	hold time (repeated) START condition		4.0	-	0.6	-	0.26	-	μs
t _{SU;STA}	set-up time for a repeated START condition		4.7	-	0.6	-	0.26	-	μs
t _{SU;STO}	set-up time for STOP condition		4.0	-	0.6	-	0.26	-	μs
t _{HD;DAT}	data hold time		0	-	0	-	0	-	ns
t _{VD;ACK}	data valid acknowledge time	[2]	-	3.45	-	0.9	-	0.45	μs
t _{VD;DAT}	data valid time	[3]	-	3.45	-	0.9	-	0.45	μs
t _{SU;DAT}	data set-up time		250	-	100	-	50	-	ns
t _{LOW}	LOW period of the SCL clock		4.7	-	1.3	-	0.5	-	μs
t _{HIGH}	HIGH period of the SCL clock		4.0	-	0.6	-	0.26	-	μs
t _f	fall time of both SDA and SCL signals		-	300	20 × (V _{DD} / 5.5 V)	300	20 × (V _{DD} / 5.5 V)	120	ns
t _r	rise time of both SDA and SCL signals		-	1000	20	300	-	120	ns
t _{SP}	pulse width of spikes that must be suppressed by the input filter	[4]	-	50	-	50	-	50	ns
Port timing									
t _{v(Q)}	data output valid time		-	200	-	200	-	200	ns

[1] Fm+ mode on a non-standard, lightly loaded bus (<100 pF).

[2] t_{VD;ACK} = time for Acknowledgement signal from SCL LOW to SDA (out) LOW.

[3] t_{VD;DAT} = minimum time for SDA data out to be valid following SCL LOW.

[4] Input filters on the SDA and SCL inputs suppress noise spikes less than 50 ns.

13. Power-on reset requirements

In the event of a glitch or data corruption, the device can be reset to its default conditions by using the power-on reset feature. Power-on reset requires that the device go through a power cycle to be completely reset. This reset also happens when the device is powered on for the first time in an application.

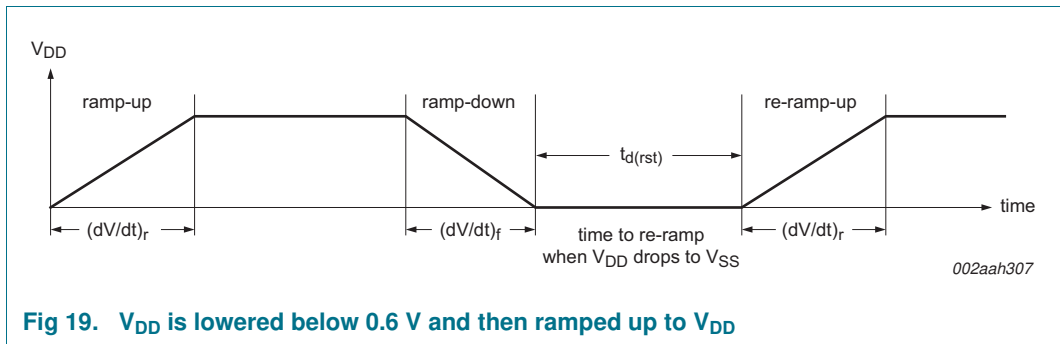

Fig 19. V_{DD} is lowered below 0.6 V and then ramped up to V_{DD}

Table 7. Recommended supply sequencing and ramp rates

T_{amb} = 25 °C (unless otherwise noted). Not tested; specified by design.

Symbol	Parameter	Condition	Min	Typ	Max	Unit
(dV/dt) _f	fall rate of change of voltage	Figure 19	0.1	-	2000	ms
(dV/dt) _r	rise rate of change of voltage	Figure 19	0.1	-	2000	ms
t _{d(rst)}	reset delay time	Figure 19; when V _{DD} drops to V _{SS}	1	-	-	μs
ΔV _{DD(gl)}	glitch supply voltage difference	Figure 20 [1]				
		V _{DD} = 2.1 V to 3.6 V	-	-	1.2	V
		V _{DD} = 1.1 V to 2.1 V	-	-	V _{DD} - 0.9	V
t _{w(gl)VDD}	supply voltage glitch pulse width	Figure 20 [2]	-	-	10	μs
V _{POR(trip)}	power-on reset trip voltage	rising V _{DD}	-	0.7	1.0	V

[1] Level that V_{DD} can glitch down to with a ramp rate of 0.4 μs/V, but not cause a functional disruption when t_{w(gl)VDD} = 1 μs.

[2] Glitch width that will not cause a functional disruption when V_{DD} = 1.8 V to 3.6 V, ΔV_{DD(gl)} = 0.5 × V_{DD}; V_{DD} = 1.1 V to 1.8 V, ΔV_{DD(gl)} = V_{DD} - 0.9 V.

Glitches in the power supply can also affect the power-on reset performance of this device. The glitch width (t_{w(gl)VDD}) and glitch height (ΔV_{DD(gl)}) are dependent on each other. The bypass capacitance, source impedance, and device impedance are factors that affect power-on reset performance. Figure 20 and Table 7 provide more information on how to measure these specifications.

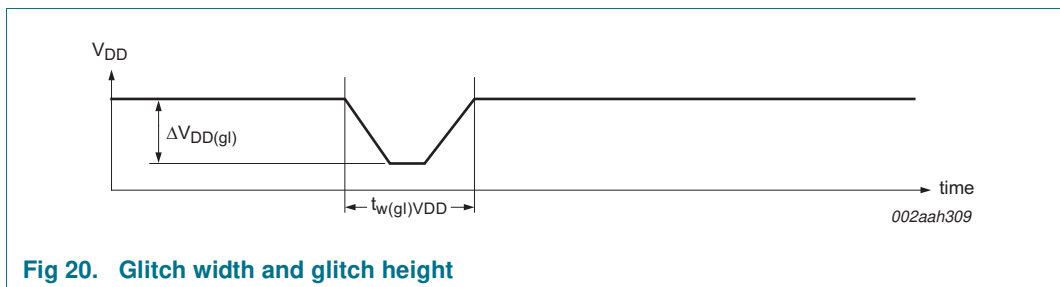

Fig 20. Glitch width and glitch height

V_{POR} is critical to the power-on reset. V_{POR} is the voltage level at which the reset condition is released and all the registers and the I²C-bus/SMBus state machine are initialized to their default states. [Figure 21](#) and [Table 7](#) provide more details on this specification.

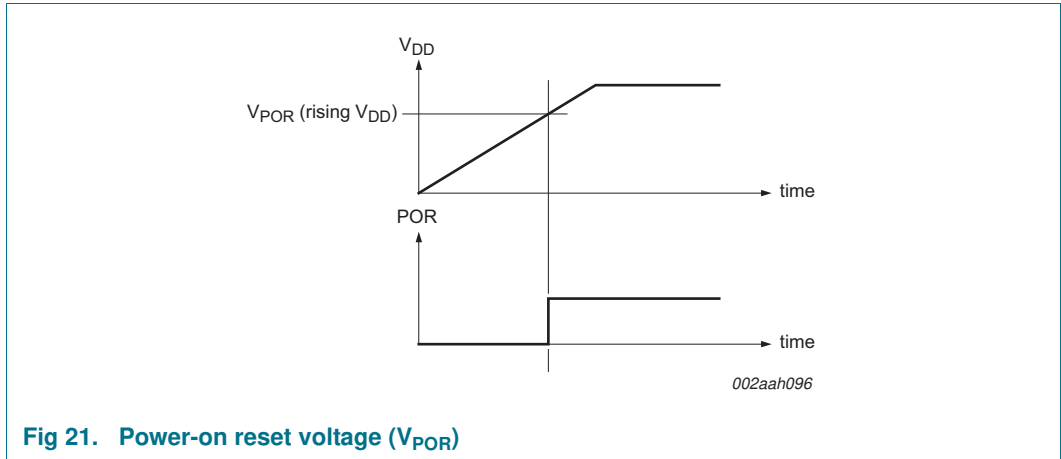

Fig 21. Power-on reset voltage (V_{POR})

14. Parameter measurement information

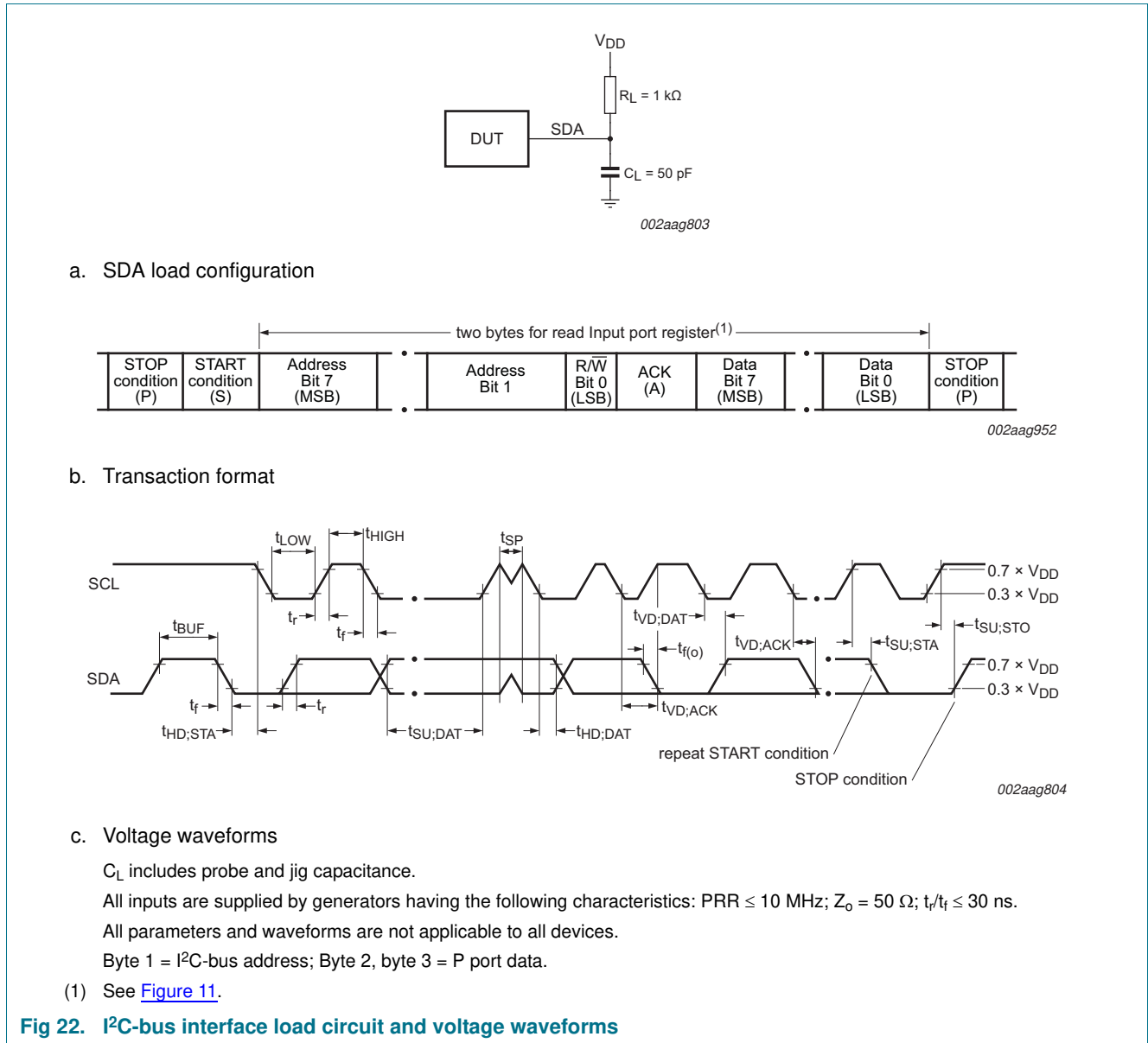
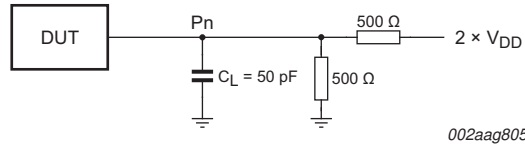
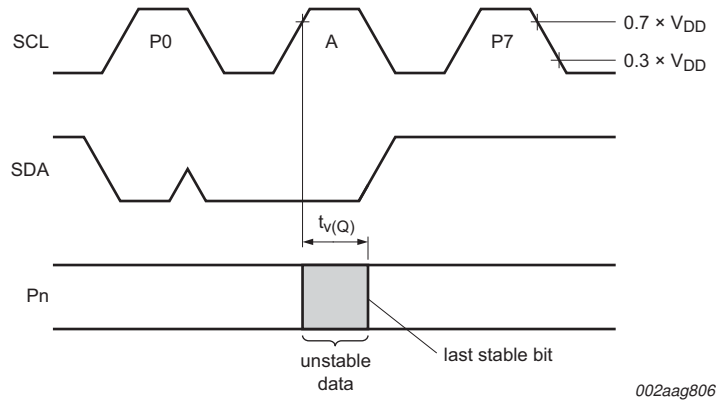

Fig 22. I²C-bus interface load circuit and voltage waveforms



a. P port load configuration



b. Write mode ($\overline{R/\overline{W}} = 0$)

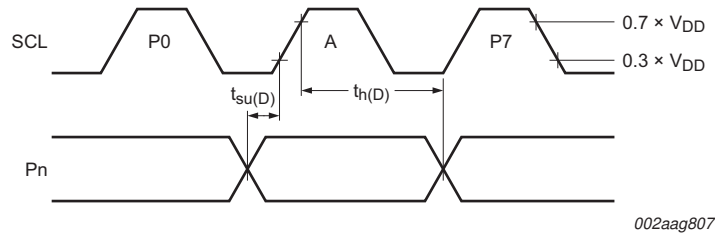

c. Read mode ($\overline{R/\overline{W}} = 1$)

C_L includes probe and jig capacitance.

$t_{V(Q)}$ is measured from $0.7 \times V_{DD}$ on SCL to 50 % I/O (Pn) output.

All inputs are supplied by generators having the following characteristics: PRR \leq 10 MHz; $Z_o = 50 \Omega$; $t_r/t_f \leq 30$ ns.

The outputs are measured one at a time, with one transition per measurement.

All parameters and waveforms are not applicable to all devices.

Fig 23. P port load circuit and voltage waveforms

15. Package outline

XQFN12: plastic, extremely thin quad flat package; no leads;
12 terminals; body 1.70 x 2.00 x 0.50 mm

SOT1174-1

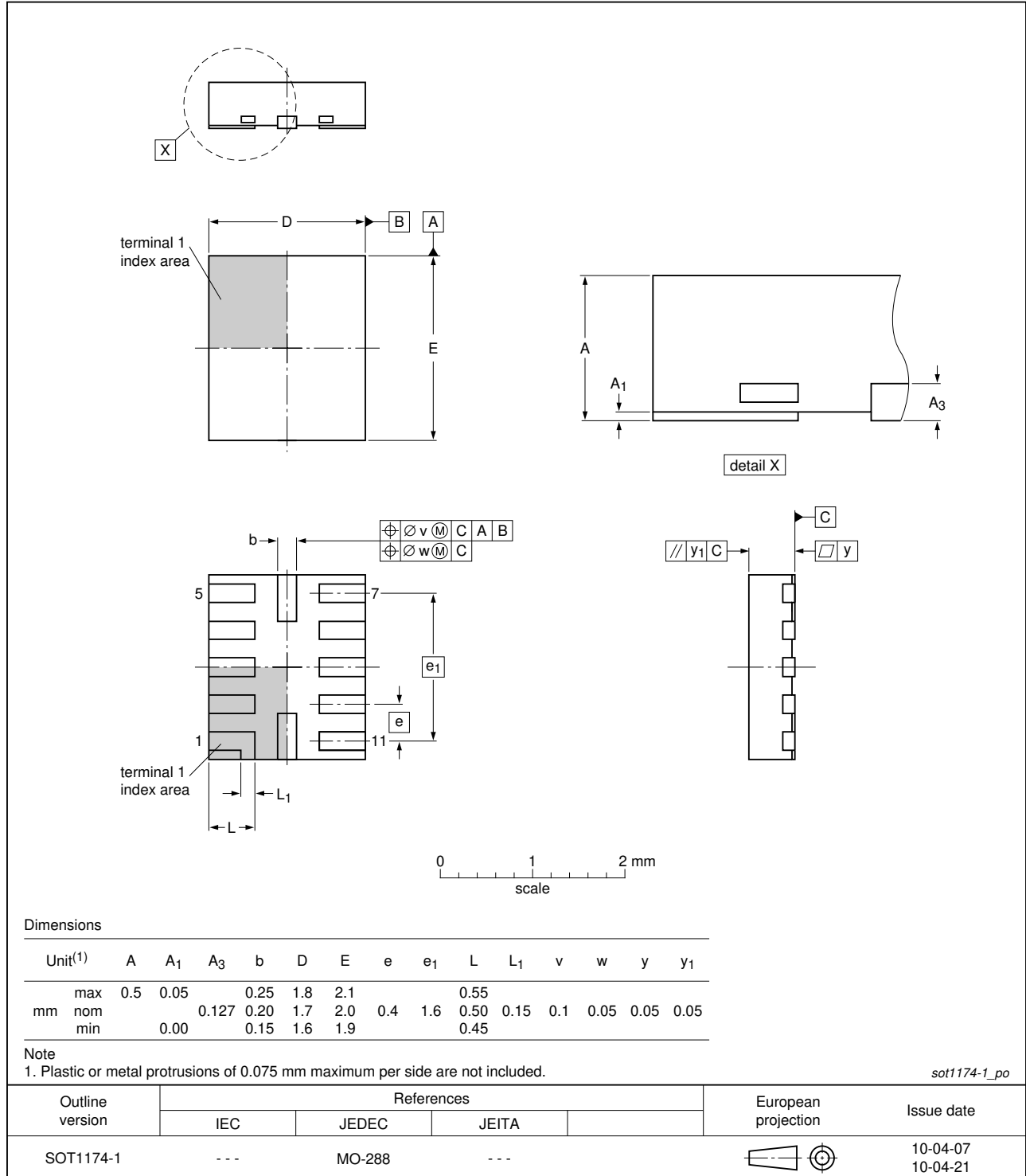

Fig 24. Package outline SOT1174-1 (XQFN12)

16. Handling information

All input and output pins are protected against ElectroStatic Discharge (ESD) under normal handling. When handling ensure that the appropriate precautions are taken as described in *JESD625-A* or equivalent standards.

17. Soldering of SMD packages

This text provides a very brief insight into a complex technology. A more in-depth account of soldering ICs can be found in Application Note *AN10365 "Surface mount reflow soldering description"*.

17.1 Introduction to soldering

Soldering is one of the most common methods through which packages are attached to Printed Circuit Boards (PCBs), to form electrical circuits. The soldered joint provides both the mechanical and the electrical connection. There is no single soldering method that is ideal for all IC packages. Wave soldering is often preferred when through-hole and Surface Mount Devices (SMDs) are mixed on one printed wiring board; however, it is not suitable for fine pitch SMDs. Reflow soldering is ideal for the small pitches and high densities that come with increased miniaturization.

17.2 Wave and reflow soldering

Wave soldering is a joining technology in which the joints are made by solder coming from a standing wave of liquid solder. The wave soldering process is suitable for the following:

- Through-hole components
- Leaded or leadless SMDs, which are glued to the surface of the printed circuit board

Not all SMDs can be wave soldered. Packages with solder balls, and some leadless packages which have solder lands underneath the body, cannot be wave soldered. Also, leaded SMDs with leads having a pitch smaller than ~0.6 mm cannot be wave soldered, due to an increased probability of bridging.

The reflow soldering process involves applying solder paste to a board, followed by component placement and exposure to a temperature profile. Leaded packages, packages with solder balls, and leadless packages are all reflow solderable.

Key characteristics in both wave and reflow soldering are:

- Board specifications, including the board finish, solder masks and vias
- Package footprints, including solder thieves and orientation
- The moisture sensitivity level of the packages
- Package placement
- Inspection and repair
- Lead-free soldering versus SnPb soldering

17.3 Wave soldering

Key characteristics in wave soldering are:

- Process issues, such as application of adhesive and flux, clinching of leads, board transport, the solder wave parameters, and the time during which components are exposed to the wave
- Solder bath specifications, including temperature and impurities

17.4 Reflow soldering

Key characteristics in reflow soldering are:

- Lead-free versus SnPb soldering; note that a lead-free reflow process usually leads to higher minimum peak temperatures (see [Figure 25](#)) than a SnPb process, thus reducing the process window
- Solder paste printing issues including smearing, release, and adjusting the process window for a mix of large and small components on one board
- Reflow temperature profile; this profile includes preheat, reflow (in which the board is heated to the peak temperature) and cooling down. It is imperative that the peak temperature is high enough for the solder to make reliable solder joints (a solder paste characteristic). In addition, the peak temperature must be low enough that the packages and/or boards are not damaged. The peak temperature of the package depends on package thickness and volume and is classified in accordance with [Table 8](#) and [9](#)

Table 8. SnPb eutectic process (from J-STD-020D)

Package thickness (mm)	Package reflow temperature (°C)	
	Volume (mm ³)	
	< 350	≥ 350
< 2.5	235	220
≥ 2.5	220	220

Table 9. Lead-free process (from J-STD-020D)

Package thickness (mm)	Package reflow temperature (°C)		
	Volume (mm ³)		
	< 350	350 to 2000	> 2000
< 1.6	260	260	260
1.6 to 2.5	260	250	245
> 2.5	250	245	245

Moisture sensitivity precautions, as indicated on the packing, must be respected at all times.

Studies have shown that small packages reach higher temperatures during reflow soldering, see [Figure 25](#).

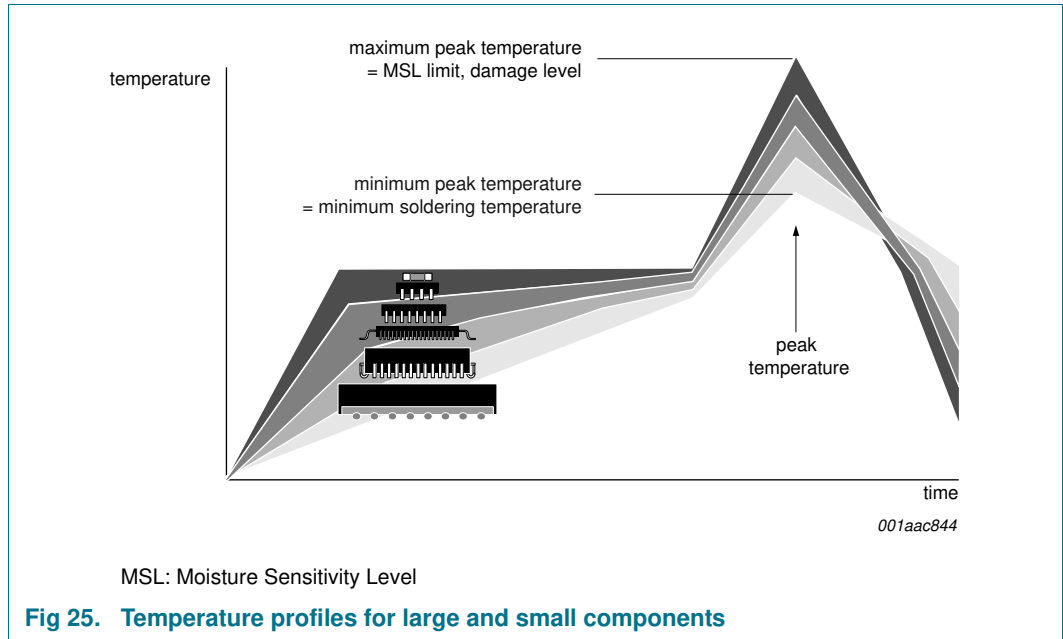

For further information on temperature profiles, refer to Application Note *AN10365* "Surface mount reflow soldering description".

18. Soldering: PCB footprints

Footprint information for reflow soldering of XQFN12 package

SOT1174-1

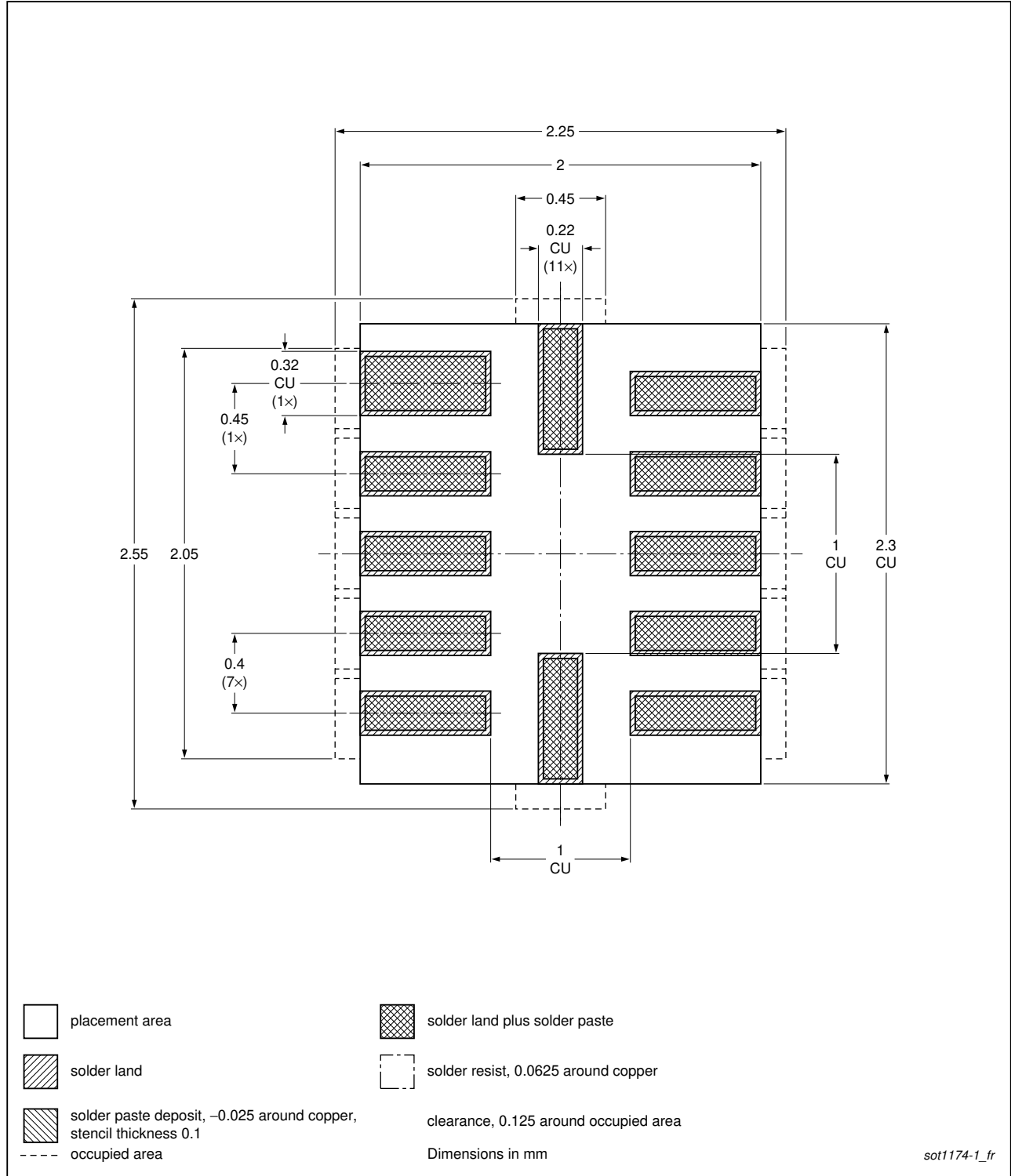

Fig 26. PCB footprint for SOT1174-1 (XQFN12); reflow soldering