



Chipsmall Limited consists of a professional team with an average of over 10 year of expertise in the distribution of electronic components. Based in Hongkong, we have already established firm and mutual-benefit business relationships with customers from,Europe,America and south Asia,supplying obsolete and hard-to-find components to meet their specific needs.

With the principle of “Quality Parts,Customers Priority,Honest Operation,and Considerate Service”,our business mainly focus on the distribution of electronic components. Line cards we deal with include Microchip,ALPS,ROHM,Xilinx,Pulse,ON,Everlight and Freescale. Main products comprise IC,Modules,Potentiometer,IC Socket,Relay,Connector.Our parts cover such applications as commercial,industrial, and automotives areas.

We are looking forward to setting up business relationship with you and hope to provide you with the best service and solution. Let us make a better world for our industry!



## Contact us

Tel: +86-755-8981 8866 Fax: +86-755-8427 6832

Email & Skype: info@chipsmall.com Web: www.chipsmall.com

Address: A1208, Overseas Decoration Building, #122 Zhenhua RD., Futian, Shenzhen, China





# PCA9615

## 2-channel multipoint Fast-mode Plus differential I<sup>2</sup>C-bus buffer with hot-swap logic

Rev. 1.1 — 10 May 2016

Product data sheet

### 1. General description

---

The PCA9615 is a Fast-mode Plus (Fm+) SMBus/I<sup>2</sup>C-bus buffer that extends the normal single-ended SMBus/I<sup>2</sup>C-bus through electrically noisy environments using a differential SMBus/I<sup>2</sup>C-bus (dI<sup>2</sup>C) physical layer, which is transparent to the SMBus/I<sup>2</sup>C-bus protocol layer. It consists of two single-ended to differential driver channels for the SCL (serial clock) and SDA (serial data).

The use of differential transmission lines between identical dI<sup>2</sup>C bus buffers removes electrical noise and common-mode offsets that are present when signal lines must pass between different voltage domains, are bundled with hostile signals, or run adjacent to electrical noise sources, such as high energy power supplies and electric motors.

The SMBus/I<sup>2</sup>C-bus was conceived as a simple slow speed digital link for short runs, typically on a single PCB or between adjacent PCBs with a common ground connection. Applications that extend the bus length or run long cables require careful design to preserve noise margin and reject interference.

The dI<sup>2</sup>C-bus buffers were designed to solve these problems and are ideally suited for rugged high noise environments and/or longer cable applications, allow multiple slaves, and operate at bus speeds up to 1 MHz clock rate. Cables can be extended to at least 3 meters (3 m), or longer cable runs at lower clock speeds. The dI<sup>2</sup>C-bus buffers are compatible with existing SMBus/I<sup>2</sup>C-bus devices and can drive Standard, Fast-mode, and Fast-mode Plus devices on the single-ended side.

Signal direction is automatic, and requires no external control. To prevent bus latch up, the standard SMBus/I<sup>2</sup>C-bus side of the bus buffer, the PCA9615 employs static offset, care should be taken when connecting these to other SMBus/I<sup>2</sup>C-bus buffers that may not operate with offset.

This device is a bridge between the normal 2-wire single-ended wired-OR SMBus/I<sup>2</sup>C-bus and the 4-wire dI<sup>2</sup>C-bus.

Additional circuitry allows the PCA9615 to be used for 'hot swap' applications, where systems are always on, but require insertion or removal of modules or cards without disruption to existing signals.

The PCA9615 has two supply voltages,  $V_{DD(A)}$  and  $V_{DD(B)}$ .  $V_{DD(A)}$ , the card side supply, only serves as a reference and ranges from 2.3 V to 5.5 V.  $V_{DD(B)}$ , the line side supply, serves as the majority supply for circuitry and ranges from 3.0 V to 5.5 V.



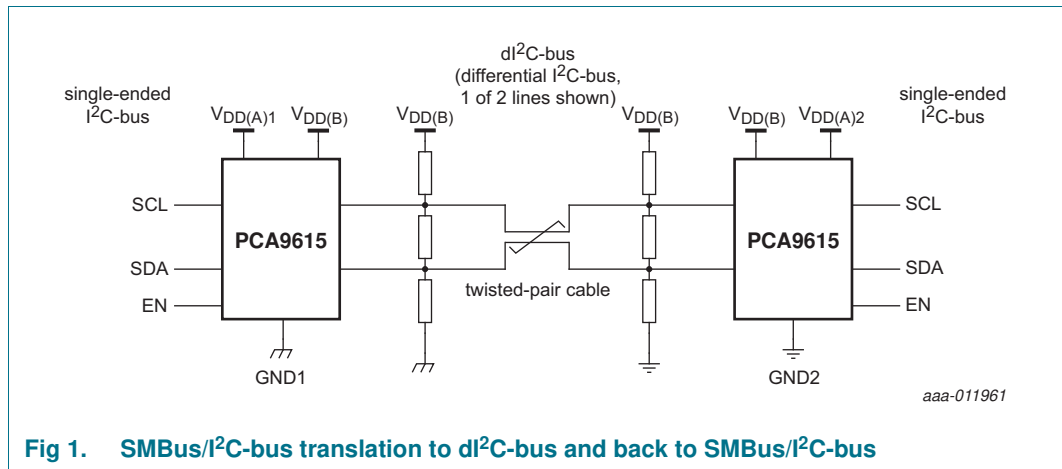

Fig 1. SMBus/I<sup>2</sup>C-bus translation to dI<sup>2</sup>C-bus and back to SMBus/I<sup>2</sup>C-bus

## 2. Features and benefits

- New dI<sup>2</sup>C-bus buffers offer improved resistance to system noise and ground offset up to 1/2 of supply voltage
- 2 channel dI<sup>2</sup>C (differential I<sup>2</sup>C-bus) to Fm+ single-ended buffer operating up to 1 MHz with 30 mA SDA/SCL drive capability
- Hot swap (allows insertion or removal of modules or card without disruption to bus data)
- EN signal (PCA9615 input) controls PCA9615 hot swap sequence
- Bus idle detect (PCA9615 internal function) waits for a bus idle condition before connection is made
- Compatible with I<sup>2</sup>C-bus Standard/Fast-mode and SMBus, Fast-mode Plus up to 1 MHz
- Single-ended I<sup>2</sup>C-bus on card side up to 540 pF
- Differential I<sup>2</sup>C-bus on cable side supporting multi-drop bus
  - ◆ Maximum cable length: 3 m (approximately 10 feet) (longer at lower frequency)
  - ◆ dI<sup>2</sup>C output: 1.5 V differential output with nominal terminals
  - ◆ Differential line impedance (user defined): 100 Ω nominal suggested
  - ◆ Receive input sensitivity: ±200 mV
  - ◆ Hysteresis: ±30 mV typical
  - ◆ Input impedance: high-impedance (200 kΩ typical)
  - ◆ Receive input voltage range: -0.5 V to +5.5 V
- Lock-up free operation
- Supports arbitration and clock stretching across the dI<sup>2</sup>C-bus buffers
- Powered-off and powering-up high-impedance I<sup>2</sup>C-bus pins
- Operating supply voltage (V<sub>DD(A)</sub>) range of 2.3 V to 5.5 V with single-ended side 5.5 V tolerant
- Differential I<sup>2</sup>C-bus operating supply voltage (V<sub>DD(B)</sub>) range of 3.0 V to 5.5 V with 5.5 V tolerant. Best operation is at 5 V.
- ESD protection exceeds 2000 V HBM per JESD22-A114 and 1000 V CDM per JESD22-C101
- Latch-up testing is done to JEDEC Standard JESD78 which exceeds 100 mA

- Package offering: TSSOP10

### 3. Applications

- Monitor remote temperature/leak detectors in harsh environment
- Control of power supplies in high noise environment
- Transmission of I<sup>2</sup>C-bus between equipment cabinets
- Commercial lighting and industrial heating/cooling control
- Any application that requires long I<sup>2</sup>C-bus runs in electrically noisy environments
- Any application with multiple power supplies and the potential for ground offsets up to 2.5 V

### 4. Ordering information

Table 1. Ordering information

Type number	Topside marking	Package		
		Name	Description	Version
PCA9615DP	P9615	TSSOP10	plastic thin shrink small outline package; 10 leads; body width 3 mm	SOT552-1

#### 4.1 Ordering options

Table 2. Ordering options

Type number	Orderable part number	Package	Packing method	Minimum order quantity	Temperature range
PCA9615DP	PCA9615DPJ	TSSOP10	Reel 13" Q1/T1 *standard mark SMD	2500	T <sub>amb</sub> = -40 °C to +85 °C

5. Block diagram

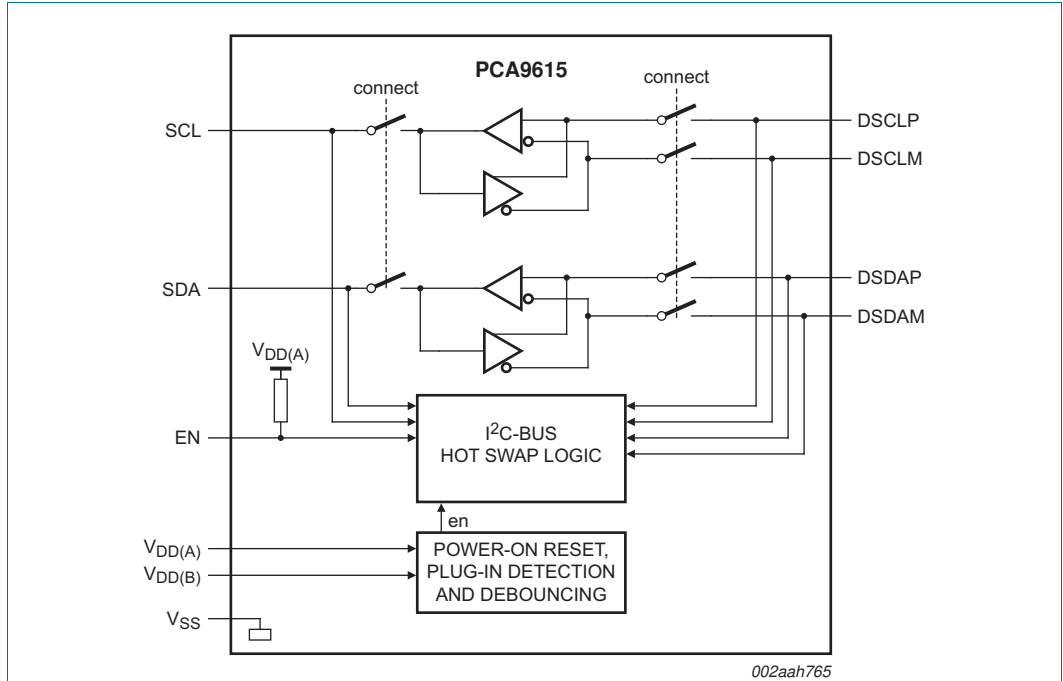

Fig 2. Block diagram (level 0)

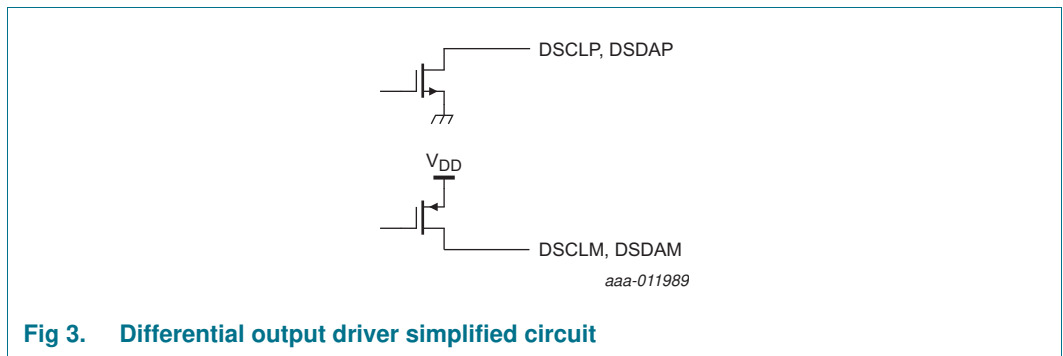
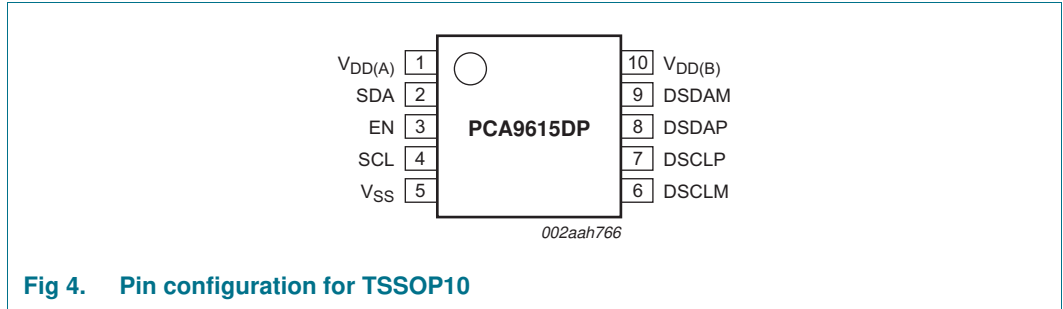

Fig 3. Differential output driver simplified circuit

## 6. Pinning information

### 6.1 Pinning



### 6.2 Pin description

**Table 3. Pin description**

Symbol	Pin	Description
V <sub>DD(A)</sub>	1	I <sup>2</sup> C-bus side power supply (2.3 V to 5.5 V)
SDA	2	card side open-drain serial data input/output
EN	3	enable input (active HIGH); internal pull-up resistor to V <sub>DD(A)</sub>
SCL	4	card side open-drain serial clock input/output
V <sub>SS</sub>	5	ground supply voltage (0 V)
DSCLM	6	line side differential open-drain clock minus input/output
DSCLP	7	line side differential open-drain clock plus input/output
DSDAP	8	line side differential open-drain data plus input/output
DSDAM	9	line side differential open-drain data minus input/output
V <sub>DD(B)</sub>	10	differential side power supply (3.0 V to 5.5 V)

## 7. Functional description

Refer to [Figure 2](#).

The PCA9615 is used at each node of the dI<sup>2</sup>C-bus signal path, to provide conversion from the dI<sup>2</sup>C-bus signal format to conventional I<sup>2</sup>C-bus/SMBus, allowing the connection of existing I<sup>2</sup>C-bus/SMBus devices as slaves or the bus master. Because the signal voltages on the I<sup>2</sup>C-bus/SMBus bus side may be different from the dI<sup>2</sup>C-bus side, there are two power supply pins and a common ground. To prevent bus latch-up, the I<sup>2</sup>C-bus/SMBus side employs static offset. Signal direction is determined by the I<sup>2</sup>C-bus/SMBus bus protocol, and does not require a direction signal, as these bus buffers automatically set signal flow direction. An enable pin (EN) is provided to disable the bus buffer, and is useful for fault finding, power-up sequencing, or reconfiguration of a large bus system by isolating sections not needed at all times.

Construction of the differential transmission line is not device-dependent. PCB traces, open wiring, twisted-pair cables or a combination of these may be used. Twisted-pair cables offer the best performance. A typical twisted-pair transmission line cable has a characteristic impedance of 'about 100 Ω' and must be terminated at both ends in 100 Ω to prevent unwanted signal reflections. Multiple nodes (each using a dI<sup>2</sup>C-bus buffer) may be connected at any point along this transmission line, however, the stub length degrades the bus performance, and should therefore be minimized.

### 7.1 I<sup>2</sup>C-bus/SMBus side

The I<sup>2</sup>C-bus/SMBus side of the PCA9615 differential bus buffer is connected to other I<sup>2</sup>C-bus/SMBus devices and requires pull-up resistors on each of the SCL and SDA signals. The value of the resistor should be chosen based on the bus capacitance and desired data speed, being careful not to overload the driver current rating of 3 mA for Standard and Fast modes, 30 mA for Fast-mode Plus (Fm+). The I<sup>2</sup>C-bus/SMBus side of the PCA9615 is powered from the V<sub>DD(A)</sub> supply pin.

### 7.2 dI<sup>2</sup>C-bus side differential pair

In previous I<sup>2</sup>C-bus/SMBus designs, the nodes (Master and one or more Slaves) are connected by wired-OR in combination with a single pull-up resistor. This simple arrangement is not suited for long distances more than 1 meter (1 m) or about 3 feet (3 ft), due to ringing and reflections on the un-terminated bus. The use of a transmission line with correct termination eliminates this problem, and is further improved by differential signaling used in the dI<sup>2</sup>C-bus scheme. Each node acts as both a driver and a receiver to allow bidirectional signal flow, but not at the same time. Switching from transmit to receive is done automatically. The dI<sup>2</sup>C-bus side of the PCA9615 is powered from the V<sub>DD(B)</sub> supply pin.

The dI<sup>2</sup>C-bus is also biased to an idle state (D+ more positive than D-) to be compatible with the I<sup>2</sup>C-bus/SMBus wired-OR scheme, when not transmitting traffic (data). This allows every node to receive broadcast messages from the Master, and return ACK/NACK and data in response. Biasing is done with additional resistors, connected to V<sub>DD(B)</sub> and V<sub>SS</sub> (the local ground), as shown in [Figure 5](#). The transmission line is terminated in the characteristic impedance of the cable, typically 100 Ω. This is the value defined by three resistors, the other two resistors providing the idle condition bias to the twisted pair.

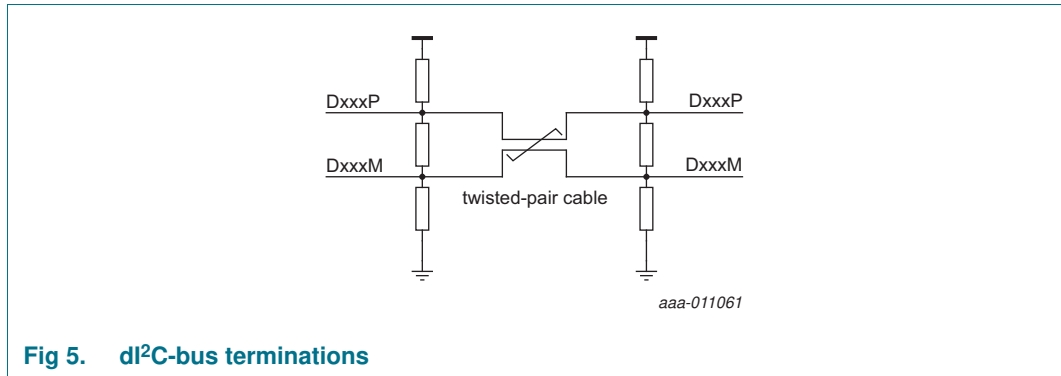

Fig 5. dI<sup>2</sup>C-bus terminations

### 7.2.1 Noise rejection

Impulse noise coupled into the I<sup>2</sup>C-bus/SMBus signals can prevent the I<sup>2</sup>C-bus/SMBus bus from operating reliably. The hostile signals may appear on the SCL line, SDA line, or both. Impulse noise may also enter the common ground connection, or be caused by current in the ground path caused by DC power supplies, or other signals sharing the common ground return path. This problem is removed by using a differential transmission line, in place of the I<sup>2</sup>C-bus/SMBus signal path. The dI<sup>2</sup>C-bus receiver (at each dI<sup>2</sup>C-bus node) subtracts the signals on the two differential lines (D+ and D-), and eliminates any common-mode noise that is coupled into the dI<sup>2</sup>C-bus. The receiver amplifies the signals which are also attenuated by the bulk resistance of the transmission line cable connection, and does not rely on a common ground connection at each node.

### 7.2.2 Rejection of ground offset voltage

Hostile signals interfere with the I<sup>2</sup>C-bus/SMBus bus through the common ground connection between each node. Current in this ground path causes an offset that may cause false data or push the I<sup>2</sup>C-bus/SMBus signals outside of an acceptable range. Unwanted ground offset can be caused by heavy DC current in the ground path, or injection of ground current from AC signals, either of which may show up as false signals.

Because the dI<sup>2</sup>C-bus node receiver responds only to the difference between the two dI<sup>2</sup>C-bus transmission lines, common-mode signals are ignored. There is no need to have a ground connection between each of the nodes, which may be powered locally. Nodes may also be powered by extra conductors (for V<sub>DD</sub> and ground) run with the dI<sup>2</sup>C-bus signals. Voltage offsets caused by DC current in these additional wires are ignored by the dI<sup>2</sup>C-bus receiver, which subtracts the two differential signals (D+ and D-).

### 7.3 EN pin

Enable input to connect the device into the bus. When this pin is LOW, the device never connects to the bus, and disconnect the SCL/SDA from differential SCL/SDA. When EN is driven HIGH, and V<sub>DD(A)</sub> and V<sub>DD(B)</sub> are stable, the EN pin connects SDA/SCL to differential SDA/SCL after a stop bit or bus idle has been detected on differential line bus. It should never change state during an I<sup>2</sup>C-bus/SMBus operation because disabling during a bus operation hangs the bus and enabling part way through a bus cycle could confuse the I<sup>2</sup>C-bus/SMBus parts being enabled. The EN pin should only change state when the global bus and the buffer port are in an idle state to prevent system failures.



### 7.4 Hot swap and power-on reset

During a power-on sequence, an initialization circuit holds the PCA9615 in a disconnected state, meaning all outputs — SDA, SCL and the differential pins DSCLP/DSCLM and DSDAP/DSDAM — are in a high-impedance state. As the power supply rises (either power-up or live insertion), the initialization circuit enters a state where the internal references are stabilized and an internal timer is triggered. After 1 ms, power is applied to the rest of the circuitry and the PCA9615 detects the status on the differential DSCLP/DSCLM and DSDAP/DSDAM lines. When the differential lines are detected as connected to a bus with valid termination, that is, both DSCLM/DSDAM < 0.9 × V<sub>DD(B)</sub> and DSCLP/DSDAP > 0.1 × V<sub>DD(B)</sub>, another timer is triggered. At the end of 10 ms, hot-swap logic (Figure 2) is enabled and the EN pin can detect a Stop Bit and Bus Idle condition. However, there is still no connection between SDA and DSDAP/DSDAM or between SCL and DSCLP/DSCLM. A successful EN pin sequence must occur for actual connection.

When the EN pin is set HIGH and the DSDAP and DSCLP pins have been HIGH for the bus idle time or when both the SCL and SDA pins are HIGH and a STOP condition has been seen on the differential bus (DSDAP/DSDAM and DSCLP/DSCLM pins), a connection is established between the differential and the single-ended buses. Whenever disconnected status is detected or the device is unpowered, the PCA9615 disconnects the single-ended to differential buses, and the hot swap sequence repeats again before the PCA9615 connects SDA to DSDAP/DSDAM and SCL to DSCLP/DSCLM.

**Remark:** Start-up process is the same for both PCA9616PW and PCA9615DP, except that PIDET and READY signals are only available in 16-pin package.

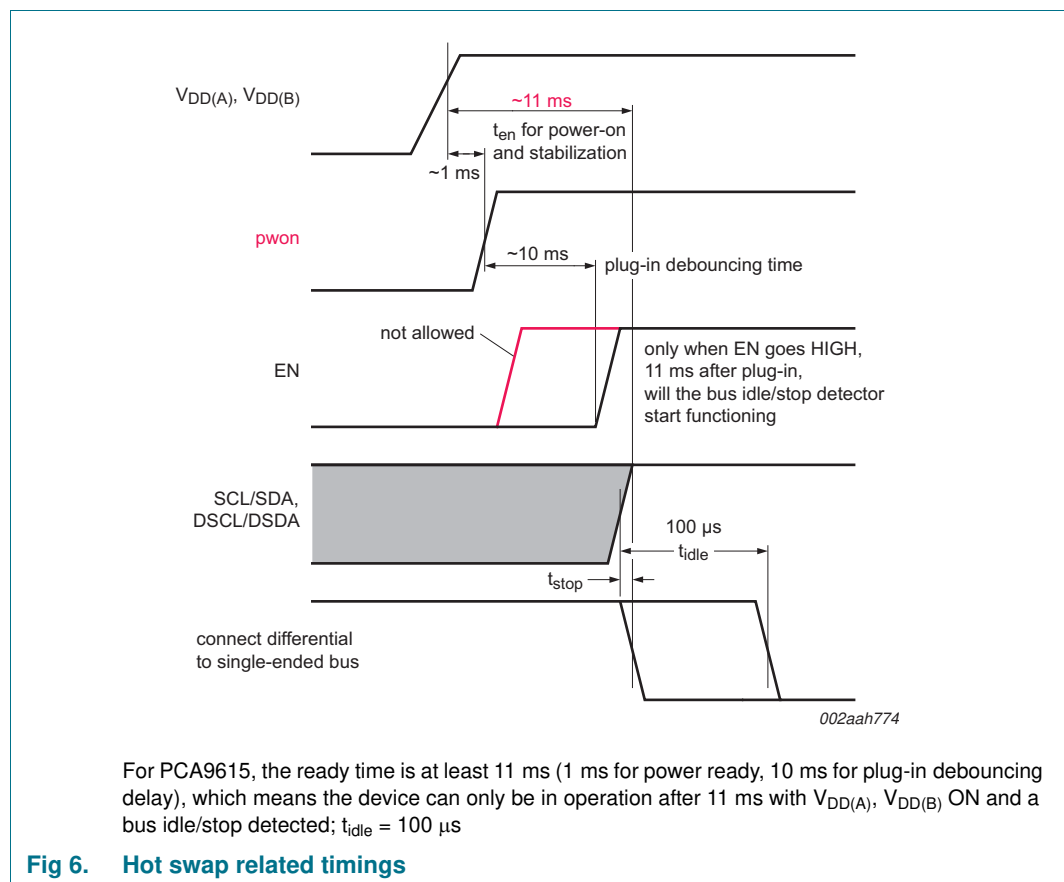

## 8. Application design-in information

### 8.1 I<sup>2</sup>C-bus

As with the standard I<sup>2</sup>C-bus system, pull-up resistors are required to provide the logic HIGH levels on the single-ended buffered bus (standard open-drain configuration of the I<sup>2</sup>C-bus). The size of these pull-up resistors depends on the system. The device is designed to work with Standard-mode, Fast-mode and Fast-mode Plus I<sup>2</sup>C-bus devices in addition to SMBus devices. Standard-mode and Fast-mode I<sup>2</sup>C-bus and SMBus devices only specify 3 mA output drive; this limits the termination current to 3 mA in a generic I<sup>2</sup>C-bus system where Standard-mode devices and multiple masters are possible. When only Fast-mode Plus devices are used, then higher termination currents can be used due to their 30 mA sink capability.

### 8.2 Differential I<sup>2</sup>C-bus application

See [Figure 7](#) through [Figure 9](#).

The simple application ([Figure 7](#)) shows an existing SMBus/I<sup>2</sup>C-bus being extended over a section of dI<sup>2</sup>C-bus transmission line, containing a dedicated twisted pair for SCL and SDA. At one end of the transmission line, a resistor network (R1-R2-R1) terminates the twisted-pair cable and biases D+ positive with respect to D-. An identical resistor network at the other end of the transmission line terminates the twisted-pair cable. DC power for each end of the transmission line and the V<sub>DD(B)</sub> of each PCA9615 bus buffer can be from separate and isolated power supplies, or use the same supply and ground run in separate wires along the same path as the dI<sup>2</sup>C-bus signal twisted pairs.

Telecom category 5 ('CAT 5') data cable is well suited for this task, but loose wires may also be used, with a reduction in performance. Assuming V<sub>DD(B)</sub> is 5 V, and using CAT 5 cable, R2 is 120 Ω, R1 is 600 Ω. The parallel combination yields a termination of 100 Ω at each end of the twisted pairs.

Either side of the dI<sup>2</sup>C-bus buffer pair is connected to standard SMBus/I<sup>2</sup>C buses, which require their own pull-up resistors to V<sub>DD(A)</sub> of the PCA9615 bus buffers. V<sub>DD(A)</sub> and V<sub>DD(B)</sub> can be the same supply, however, making them different voltages enables the PCA9615 bus buffers to level translate between the SMBus/I<sup>2</sup>C-bus and dI<sup>2</sup>C-bus sections of the bus, or to have different supply voltages and level translate at either end of the dI<sup>2</sup>C-bus and SMBus/I<sup>2</sup>C-bus system.

For example, the left-hand bus master (and local slave) may operate on a 3.3 V supply and SMBus/I<sup>2</sup>C-bus while the dI<sup>2</sup>C-bus transmission lines are at 5 V, and the right-hand slave is operated from a different 3.3 V supply and SMBus/I<sup>2</sup>C-bus, or even a different bus voltage other than 3.3 V.

Depending upon the timing from the system master, clock toggle rates can vary from 10 kHz for the SMBus (or less for SMBus/I<sup>2</sup>C-bus protocol) up to 100 kHz (Standard mode), 400 kHz (Fast mode), or up to 1 MHz (Fast-mode Plus).

The bus path is bidirectional. Assume that the left side SMBus/I<sup>2</sup>C-bus becomes active. A START condition (SDA goes LOW while SDA is HIGH) is sent. This upsets the idle condition on the dI<sup>2</sup>C-bus section of the bus, because D+ was more positive than D- and

now they are reversed. The right side bus buffer sees the differential lines change polarity and in turn pulls SDA LOW on the SMBus/I<sup>2</sup>C-bus side of the bus buffer, transmitting the START condition to the slave on that section of the SMBus/I<sup>2</sup>C-bus.

If the data clocked out by the left side master contains a valid address of the right side slave, that slave responds by pulling SDA LOW on the ninth clock. This condition is transmitted across the dI<sup>2</sup>C-bus section that has now changed flow direction, and received by the left side bus buffer (again, D+ was more positive than D- and now they are reversed).

This sequence continues until the master sends the STOP condition (SCL HIGH while SDA goes HIGH), placing the active slave (on the right side) back to idle. When idle, the normal SMBus/I<sup>2</sup>C-bus (both left and right sections) are pulled up by their respective pull-ups. In turn, the dI<sup>2</sup>C-bus section of the bus rests with D+ more positive than D-.

The idle condition can be changed by any node on either SMBus/I<sup>2</sup>C-bus section or an additional dI<sup>2</sup>C-bus node, if present, on the dI<sup>2</sup>C-bus section of the system. This allows the existing SMBus/I<sup>2</sup>C-bus protocol to operate transparently over a mix of SMBus/I<sup>2</sup>C and dI<sup>2</sup>C bus segments.

Due to the SMBus/I<sup>2</sup>C-bus handshake protocol (ACK/NACK on the ninth clock pulse), the direction of the SMBus/I<sup>2</sup>C-bus is reversed often. The 'time of flight' for the signals to pass through each bus buffer and for the target slave to respond defines the maximum speed of the bus, regardless of how fast the clock toggles. The dI<sup>2</sup>C-bus section of the bus requires two additional PCA9615 bus buffers, further delaying the SMBus/I<sup>2</sup>C-bus traffic. If the dI<sup>2</sup>C-bus transmission line section is made longer, the bus operates much slower, regardless of the clock toggle speed.

It is not necessary to have a ground connection between each end of the dI<sup>2</sup>C section of the bus. The dI<sup>2</sup>C-bus receiver responds to reversal of the polarity of the D+ and D- signals, and ignores the common-mode voltage that may be present.

Ideally, the common-mode voltage is the same at each end of the twisted pairs, and no current flows along the twisted pair when the bus is idle, because the D+ and D- dI<sup>2</sup>C-bus drivers are both high-impedance, the bus is biased by R1-R2-R1 at each end. If the common-mode voltage is not 0 V, current flows along the twisted pair, returning through the common ground or common power supply connection if present.

If both ends of the twisted pair are powered by the same V<sub>DD(B)</sub> supply and one end is remote, there will be a common-mode offset between them. This is ignored by the dI<sup>2</sup>C-bus receivers, which only respond to the difference between D+ and D-.

However, a large common-mode offset voltage forces the D+ and D- signals out of the range of the receiver, and data are lost. The PCA9615 bus buffers use standard ESD protection networks to protect the external pins, and therefore should not be biased above or below the V<sub>DD(B)</sub> and V<sub>SS</sub> pins respectively. This limits the common-mode range to approximately  $0.5 \times V_{DD(B)}$ .

DC resistance of the transmission line attenuates the signals, more so over longer distances. The loss of signal amplitude is made up by the gain of the dI<sup>2</sup>C-bus receiver. There is a limit to how long the dI<sup>2</sup>C-bus section can be made, as it is necessary for the driver to overcome the bias on the transmission line, in order to signal a polarity change (D+ and D- reversal) at the receiver end.

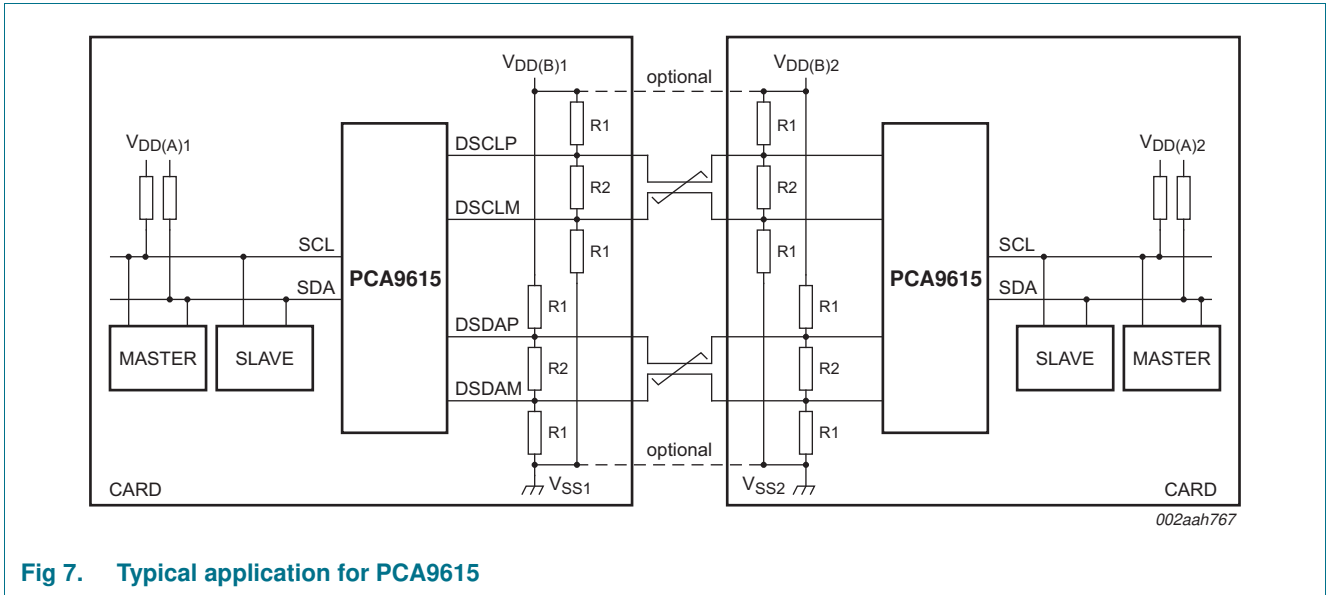
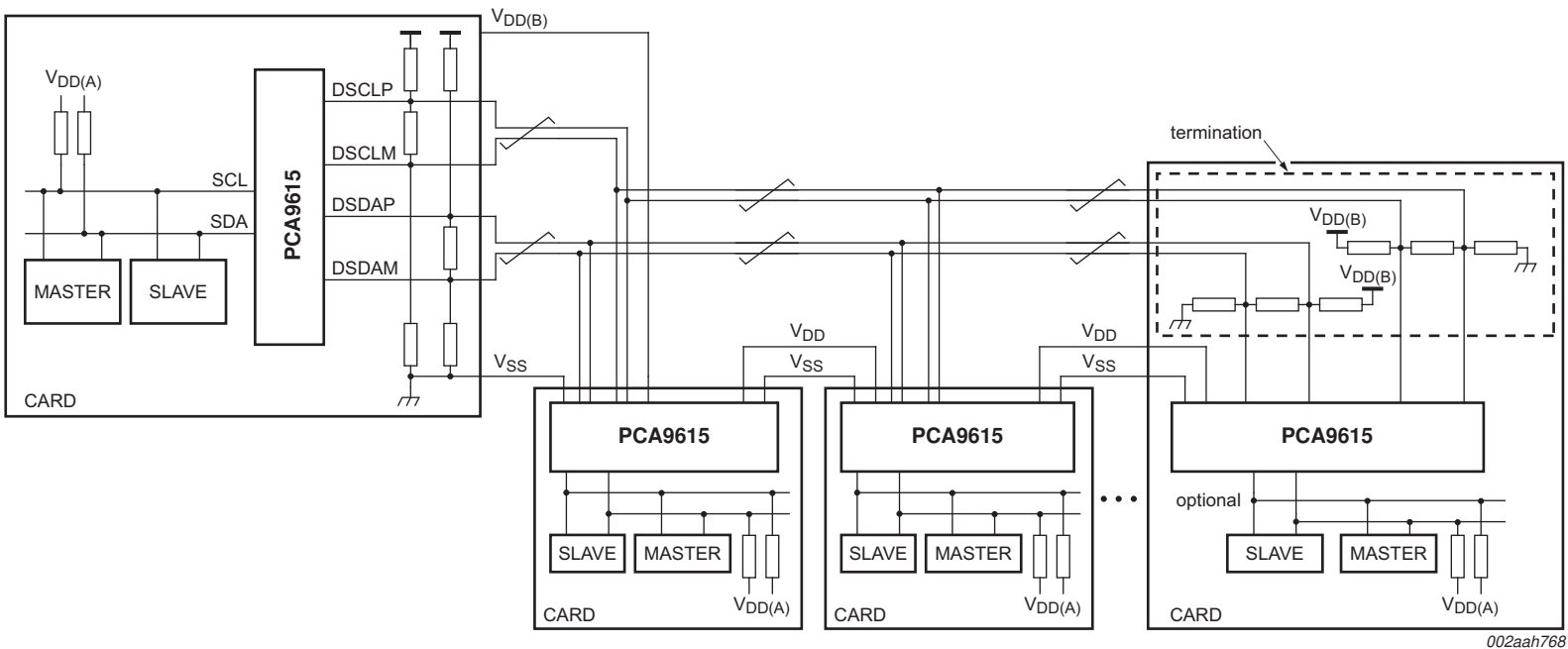

Fig 7. Typical application for PCA9615



002aah768

**Remark:** Keep drops as short as possible.

**Remark:** There is only one ground pin on the PCA9615, so the single-ended I<sup>2</sup>C-bus signals that are not ground offset tolerant must be referenced to the ground pin on the part. And any ground offset must be on the differential side where the differential input and output can tolerate a ground offset of up to  $0.5 \times V_{DD(B)}$ .

**Fig 8.** PCA9615 application diagram;  $V_{DD}$  and  $V_{SS}$  are routed through the cable

2-channel multipoint Fm+ dI<sup>2</sup>C-bus buffer with hot-swap logic

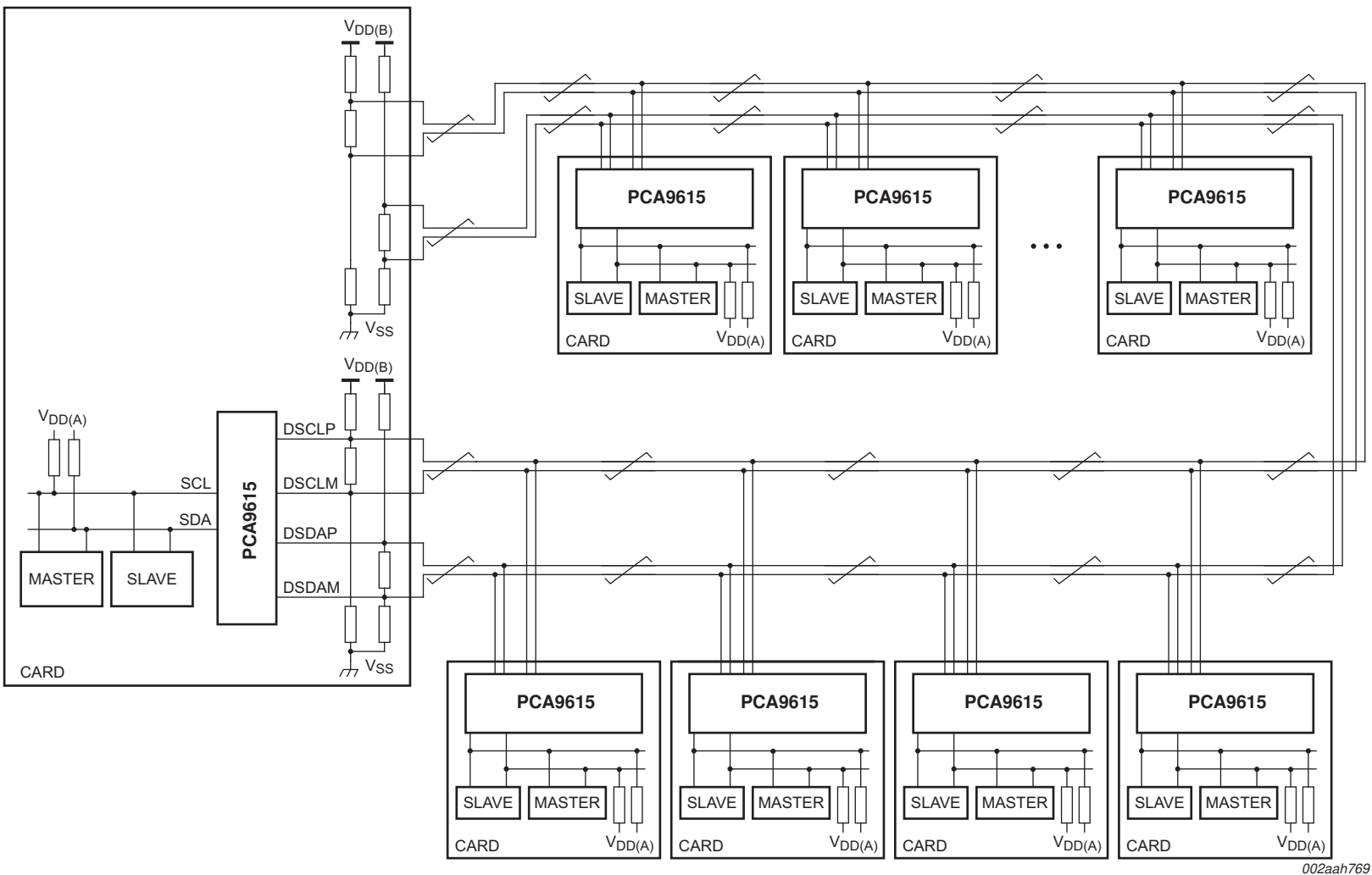

002aah769

Fig 9. PCA9615 application diagram; V<sub>DD</sub> and V<sub>SS</sub> are not routed through the cable

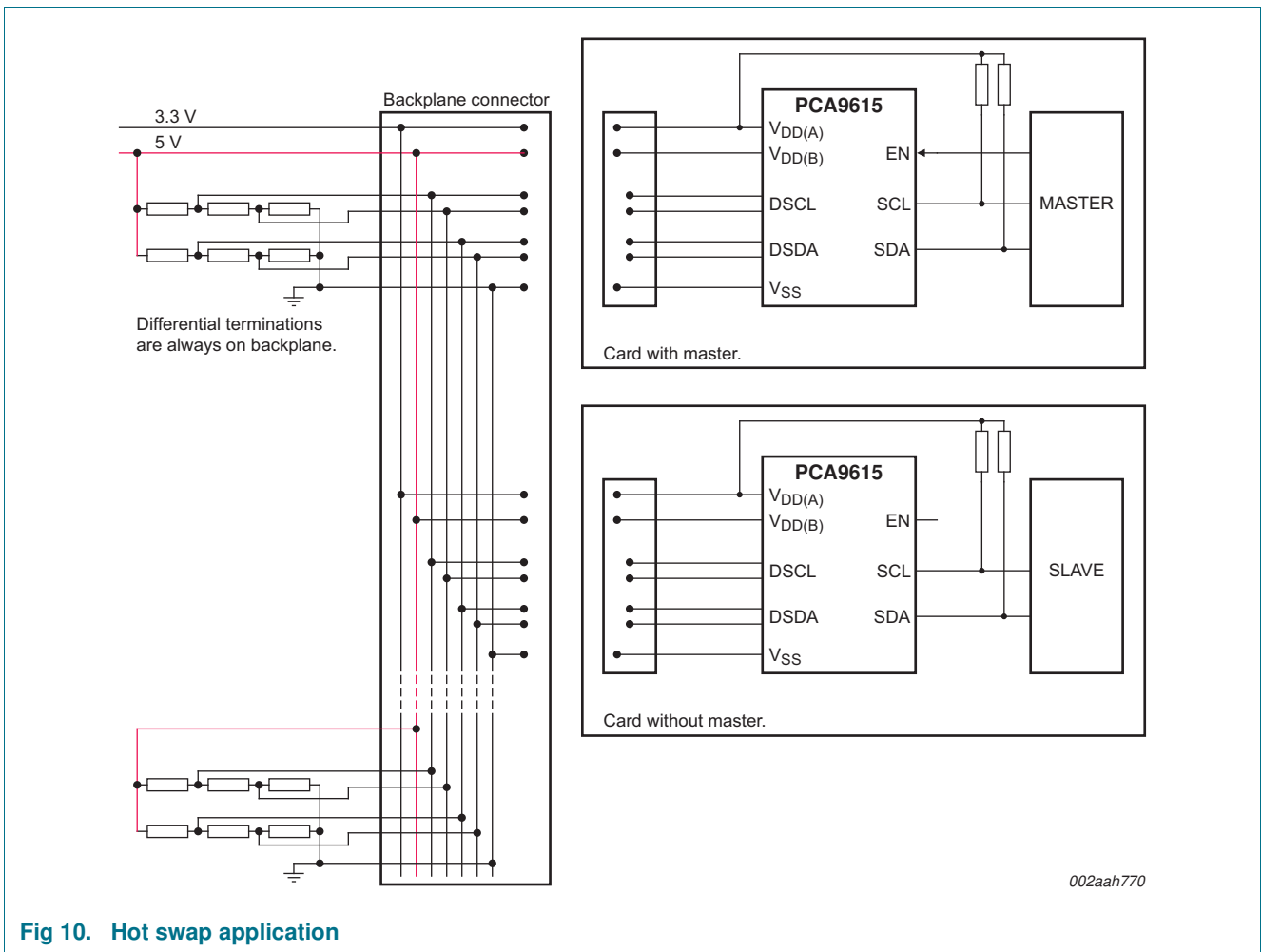



aaa-011062

Fig 11. Differential bus waveform

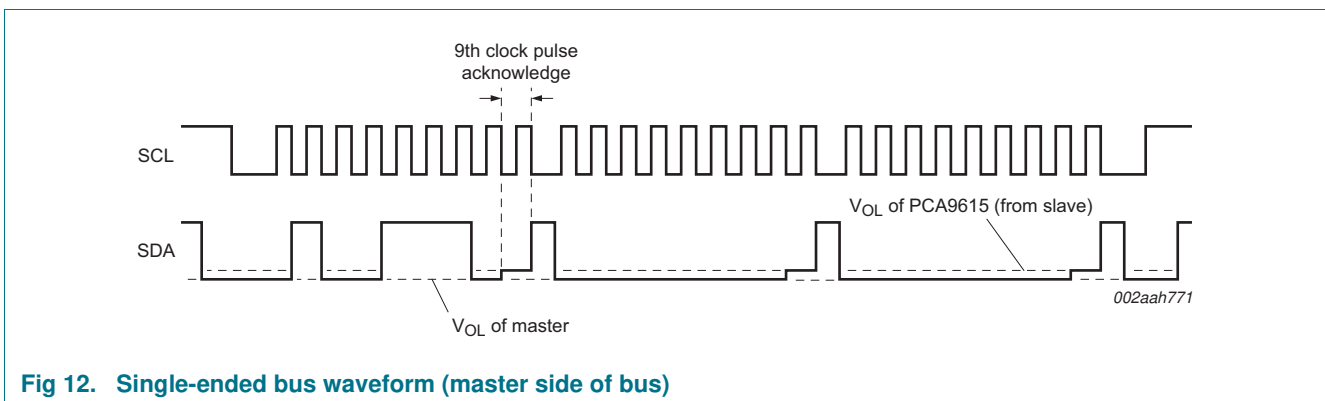

Fig 12. Single-ended bus waveform (master side of bus)



## 9. Limiting values

**Table 4. Limiting values**

*In accordance with the Absolute Maximum Rating System (IEC 60134).*

Symbol	Parameter	Conditions	Min	Max	Unit
V <sub>DD(B)</sub>	supply voltage port B	differential bus; 3.0 V to 5.5 V	-0.5	+6	V
V <sub>DD(A)</sub>	supply voltage port A	single-ended bus; 2.3 V to 5.5 V	-0.5	+6	V
V <sub>O(dif)</sub>	differential output voltage		-0.5	+6	V
V <sub>bus</sub>	bus voltage	voltage on I <sup>2</sup> C-bus A side, or enable (EN)	-0.5	+6	V
I <sub>I/O</sub>	input/output current	SDA, SCL, Dxxxx	-	80	mA
I <sub>DD(B)</sub>	supply current port B		-	160	mA
P <sub>tot</sub>	total power dissipation		-	100	mW
T <sub>stg</sub>	storage temperature		-55	+125	°C
T <sub>amb</sub>	ambient temperature	operating in free air	-40	+85	°C
T <sub>j</sub>	junction temperature		-	125	°C

## 10. Static characteristics

**Table 5. Static characteristics**

$V_{DD(B)} = 3.0\text{ V to }5.5\text{ V}$ ;  $V_{SS} = 0\text{ V}$ ;  $T_{amb} = -40\text{ }^{\circ}\text{C to }+85\text{ }^{\circ}\text{C}$ ; unless otherwise specified.

Symbol	Parameter	Conditions	Min	Typ	Max	Unit
<b>Supplies</b>						
$V_{DD(B)}$	supply voltage port B	differential bus	3.0	-	5.5	V
$V_{DD(A)}$	supply voltage port A	single-ended bus	<a href="#">1</a> 2.3	-	5.5	V
$I_{DD(VDDA)}$	supply current on pin $V_{DD(A)}$		-	-	16	$\mu\text{A}$
$I_{DDH(B)}$	port B HIGH-level supply current	both channels HIGH; $V_{DD(B)} = 5.5\text{ V}$ ; $\text{SDAn} = \text{SCLn} = V_{DD(A)} = 5.5\text{ V}$	-	0.8	1.6	mA
$I_{DDL(B)}$	port B LOW-level supply current	both channels LOW; $V_{DD(B)} = 5.5\text{ V}$ ; $\text{SDA}$ and $\text{SCL} = V_{SS}$ ; differential I/Os open	-	1.1	1.8	mA
		driving termination; 2 channel	-	70	91	mA
<b>Input and output SDA and SCL</b>						
$V_{IH}$	HIGH-level input voltage		$0.7V_{DD(A)}$	-	5.5	V
$V_{IL}$	LOW-level input voltage		-0.5	-	+0.4	V
$V_{IK}$	input clamping voltage	$I_I = -18\text{ mA}$	-1.5	-	0	V
$I_{LI}$	input leakage current	$V_I = V_{DD(A)}$	-	-	$\pm 2$	$\mu\text{A}$
$I_{IL}$	LOW-level input current	SDA, SCL; $V_I = 0.2\text{ V}$	-	-	12	$\mu\text{A}$
$V_{OL}$	LOW-level output voltage	$I_{OL} = 200\text{ }\mu\text{A}$ or $30\text{ mA}$	0.47	0.52	0.6	V
$V_{OL} - V_{IL}$	difference between LOW-level output and LOW-level input voltage	guaranteed by design	-	-	90	mV
$I_{LOH}$	HIGH-level output leakage current	$V_O = V_{DD(A)}$	-	-	$\pm 2$	$\mu\text{A}$
$C_{io}$	input/output capacitance	$V_I = V_{DD(A)}$ or $0\text{ V}$ ; disabled or $V_{DD(A)} = 0\text{ V}$	-	7	10	pF
<b>Input and output DSDAP/DSDAM and DSCLP/DSCLM</b>						
$V_{cm}$	common-mode voltage		0	-	$V_{DD(B)}$	V
$I_{LI}$	input leakage current	$V_I = V_{DD(B)}$	-	-	$\pm 40$	$\mu\text{A}$
$I_{IL}$	LOW-level input current	$V_I = 0.2\text{ V}$	-	-	$\pm 40$	$\mu\text{A}$
$R_{PU}$	pull-up resistance	internal pull-up resistor on DSCLM and DSDAM connected to $V_{DD(B)}$ rail	-	200	-	k $\Omega$
$R_{pd}$	pull-down resistance	internal pull-down resistor on DSCLP and DSDAP connected to $V_{SS}$ rail	-	200	-	k $\Omega$
$V_{th(dif)}$	differential receiver threshold voltage	$0\text{ V} \leq V_{cm} \leq V_{DD(B)}$	-200	-	+200	mV
$V_{I(hys)}$	hysteresis of input voltage	receiver; $0\text{ V} \leq V_{cm} \leq V_{DD(B)}$	-	30	-	mV
$V_{o(dif)(p-p)}$	peak-to-peak differential output voltage	single-ended input LOW				
		no load	$-V_{DD(B)}$	-	-	V
		$R_L = 54\text{ }\Omega$ at $V_{DD(B)} = 5\text{ V}$	-5.0	-1.5	-1.0	V
$C_{io}$	input/output capacitance	$V_I = V_{DD(B)}$ or $0\text{ V}$ ; disabled or $V_{DD(B)} = 0\text{ V}$	-	7	10	pF

**Table 5. Static characteristics ...continued**

$V_{DD(B)} = 3.0\text{ V to }5.5\text{ V}$ ;  $V_{SS} = 0\text{ V}$ ;  $T_{amb} = -40\text{ }^{\circ}\text{C to }+85\text{ }^{\circ}\text{C}$ ; unless otherwise specified.

Symbol	Parameter	Conditions	Min	Typ	Max	Unit
<b>Input EN</b>						
$V_{IH}$	HIGH-level input voltage		$0.7V_{DD(A)}$	-	5.5	V
$V_{IL}$	LOW-level input voltage		-0.5	-	$+0.3V_{DD(A)}$	V
$I_{LI}$	input leakage current	$V_I = V_{DD(B)}$	-1	-	+1	$\mu\text{A}$
$I_{IL(EN)}$	LOW-level input current on pin EN	$V_I = 0.2\text{ V}$ , EN; $V_{DD(A)} = 5.5\text{ V}$	-	-20	-54	$\mu\text{A}$
$C_i$	input capacitance	$V_I = V_{DD(A)}$	-	6	10	pF
$R_{PU}$	pull-up resistance	internal pull-up resistor connected to $V_{DD(A)}$ rail	-	300	-	k $\Omega$

[1] LOW-level supply voltage.

## 11. Dynamic characteristics

**Table 6. Dynamic characteristics**

$V_{DD} = 2.7\text{ V to }5.5\text{ V}$ ;  $V_{SS} = 0\text{ V}$ ;  $T_{amb} = -40\text{ }^{\circ}\text{C to }+85\text{ }^{\circ}\text{C}$ ; unless otherwise specified.<sup>[1][2]</sup>

Symbol	Parameter	Conditions	Min	Typ <sup>[3]</sup>	Max	Unit
$t_{PLH}$	LOW to HIGH propagation delay	single-ended side to differential side; <a href="#">Figure 15</a>	<sup>[4]</sup> -140	-120	-	ns
$t_{PLH2}$	LOW to HIGH propagation delay 2	single-ended side to differential side; <a href="#">Figure 15</a>	-	-	100	ns
$t_{PHL}$	HIGH to LOW propagation delay	single-ended side to differential side; <a href="#">Figure 13</a>	<sup>[5]</sup> -	-	120	ns
$SR_r$	rising slew rate	differential side; <a href="#">Figure 13</a>	-	-	1	V/ns
$SR_f$	falling slew rate	differential side; <a href="#">Figure 13</a>	<sup>[5]</sup> -	-	1	V/ns
$t_{PLH}$	LOW to HIGH propagation delay	differential side to single-ended side; <a href="#">Figure 14</a>	<sup>[6]</sup> -	-	150	ns
$t_{PHL}$	HIGH to LOW propagation delay	differential side to single-ended side; <a href="#">Figure 14</a>	<sup>[6]</sup> -	-	150	ns
$SR_f$	falling slew rate	single-ended side; <a href="#">Figure 14</a>	-	-	0.1	V/ns
$t_{dis}$	disable time	EN LOW to disable	<sup>[7]</sup> -	-	200	ns

[1] Times are specified with loads of 1.35 k $\Omega$  pull-up resistance and 50 pF load capacitance on the A side, and 50  $\Omega$  termination network resistance and 50 pF load capacitance on the B side. Different load resistance and capacitance alters the RC time constant, thereby changing the propagation delay and transition times.

[2] Pull-up voltages are  $V_{DD(A)}$  on the A side and termination network on the B side.

[3] Typical values were measured with  $V_{DD(A)} = 3.3\text{ V}$  at  $T_{amb} = 25\text{ }^{\circ}\text{C}$ , unless otherwise noted.

[4] The  $t_{PLH}$  delay data from B side to A side is measured at 0 V differential on the B side to  $0.5V_{DD(A)}$  on the A side.

[5] Typical value measured with  $V_{DD(A)} = 3.3\text{ V}$  at  $T_{amb} = 25\text{ }^{\circ}\text{C}$ .

[6] The proportional delay data from A side to B side is measured at  $0.5V_{DD(A)}$  on the A side to 0 V on the B side.

[7] The enable pin (EN) should only change state when the global bus and the repeater port are in an idle state.

11.1 AC waveforms

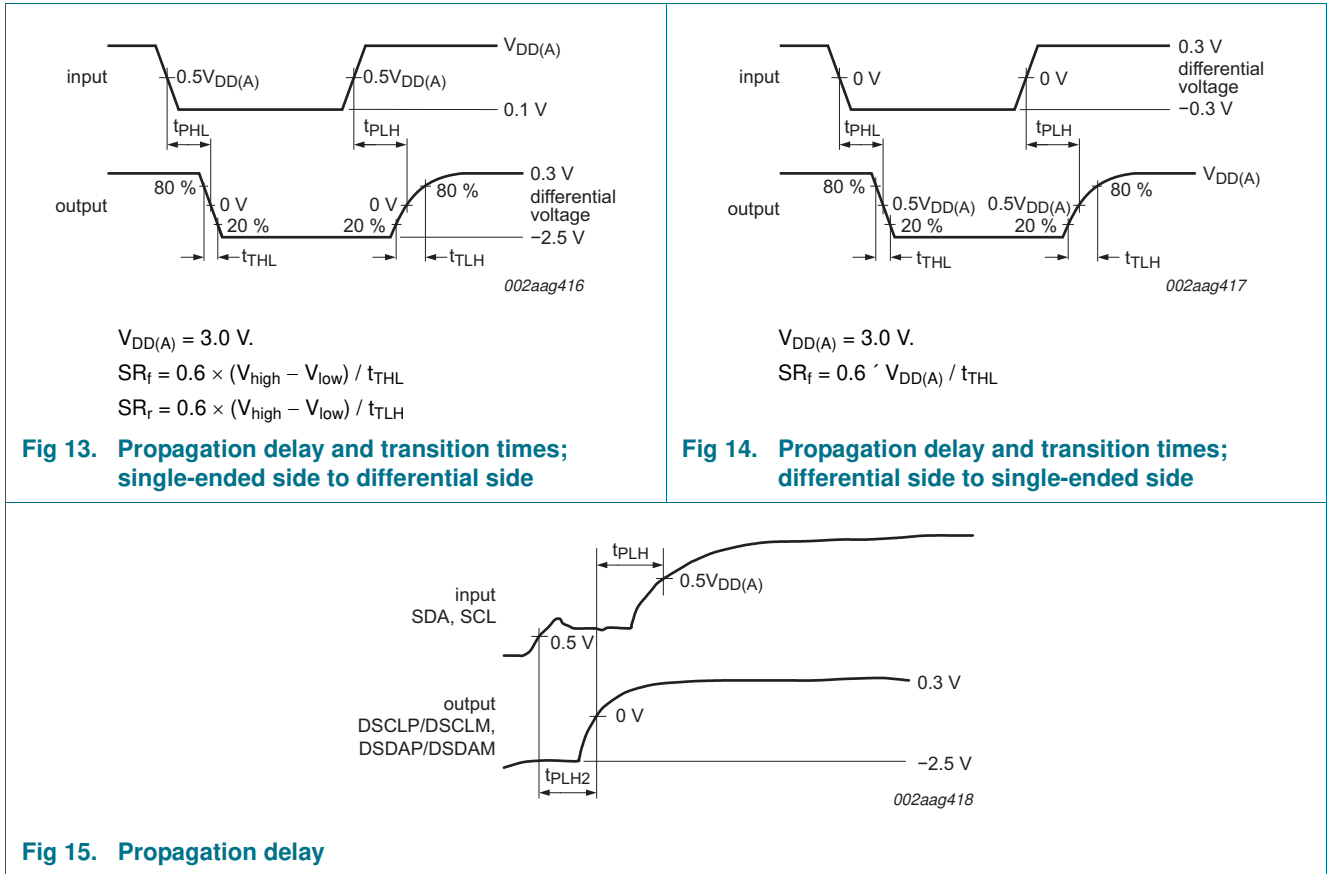

## 12. Test information

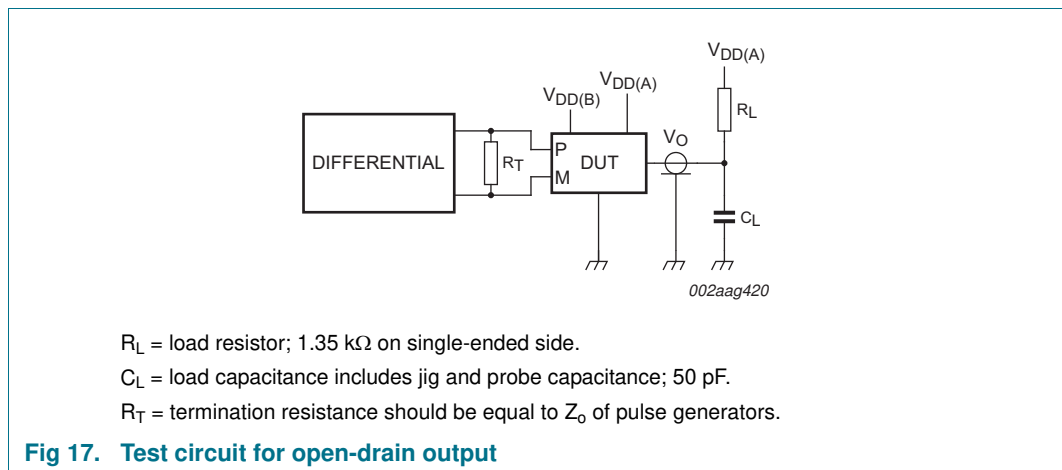
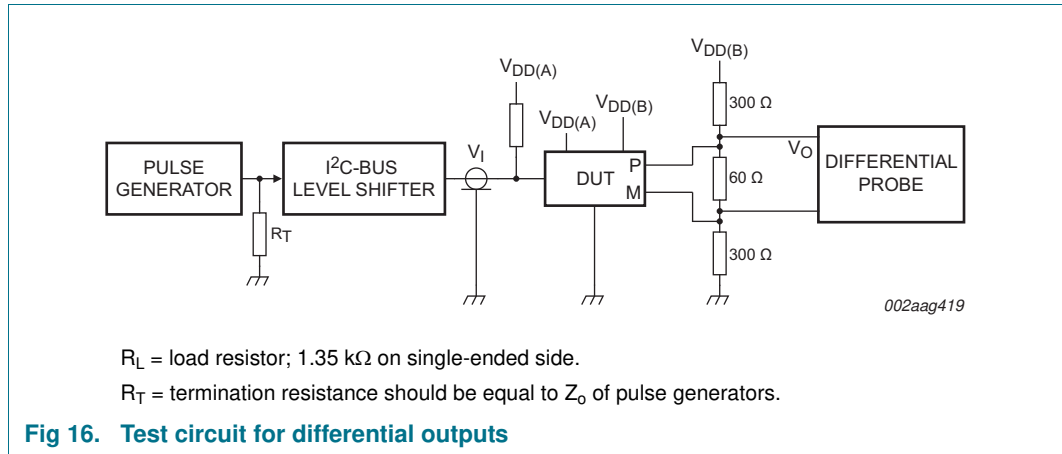

13. Package outline

TSSOP10: plastic thin shrink small outline package; 10 leads; body width 3 mm

SOT552-1

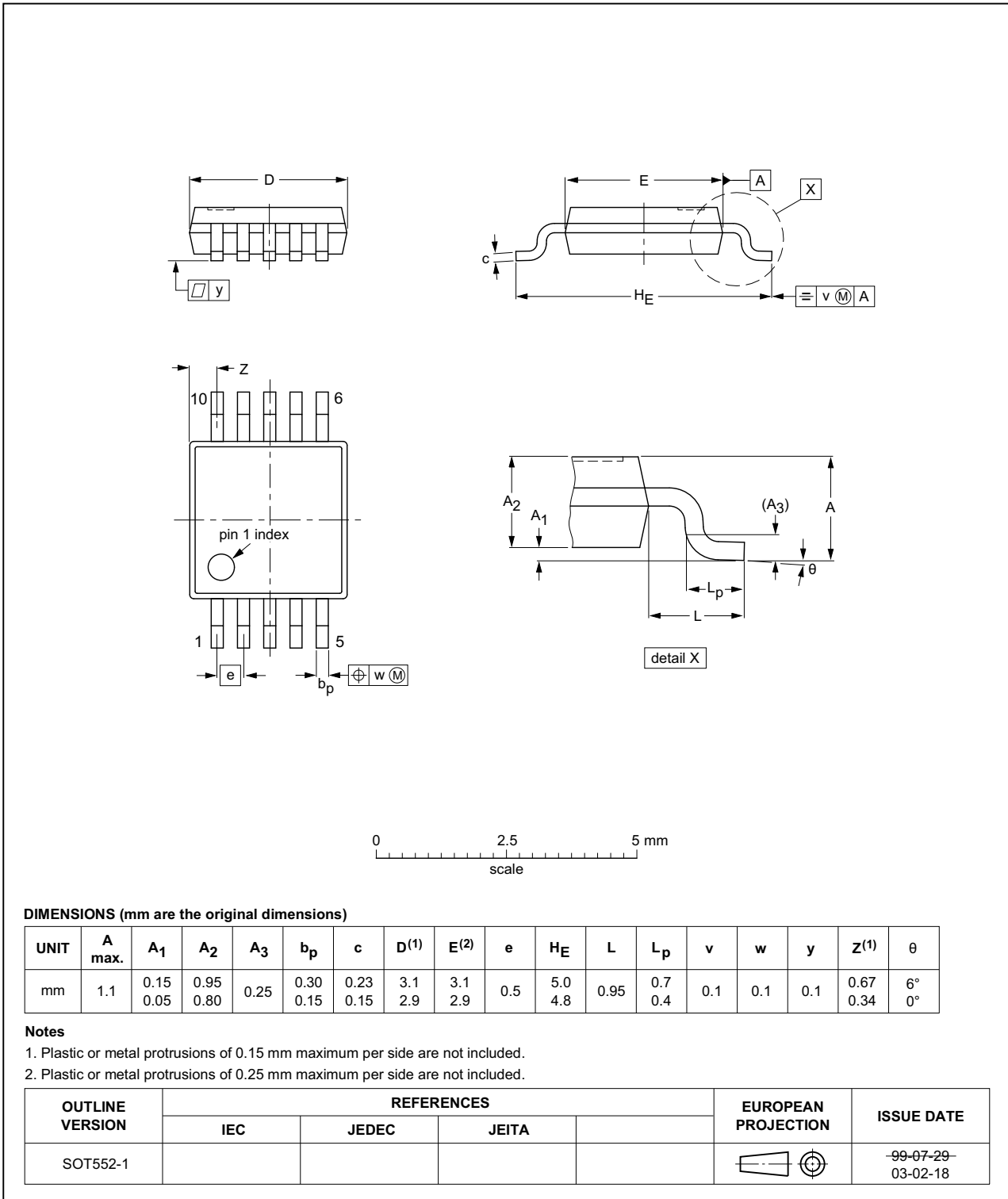

Fig 18. Package outline SOT552-1 (TSSOP10)

## 14. Soldering of SMD packages

This text provides a very brief insight into a complex technology. A more in-depth account of soldering ICs can be found in Application Note *AN10365 "Surface mount reflow soldering description"*.

### 14.1 Introduction to soldering

Soldering is one of the most common methods through which packages are attached to Printed Circuit Boards (PCBs), to form electrical circuits. The soldered joint provides both the mechanical and the electrical connection. There is no single soldering method that is ideal for all IC packages. Wave soldering is often preferred when through-hole and Surface Mount Devices (SMDs) are mixed on one printed wiring board; however, it is not suitable for fine pitch SMDs. Reflow soldering is ideal for the small pitches and high densities that come with increased miniaturization.

### 14.2 Wave and reflow soldering

Wave soldering is a joining technology in which the joints are made by solder coming from a standing wave of liquid solder. The wave soldering process is suitable for the following:

- Through-hole components
- Leaded or leadless SMDs, which are glued to the surface of the printed circuit board

Not all SMDs can be wave soldered. Packages with solder balls, and some leadless packages which have solder lands underneath the body, cannot be wave soldered. Also, leaded SMDs with leads having a pitch smaller than ~0.6 mm cannot be wave soldered, due to an increased probability of bridging.

The reflow soldering process involves applying solder paste to a board, followed by component placement and exposure to a temperature profile. Leaded packages, packages with solder balls, and leadless packages are all reflow solderable.

Key characteristics in both wave and reflow soldering are:

- Board specifications, including the board finish, solder masks and vias
- Package footprints, including solder thieves and orientation
- The moisture sensitivity level of the packages
- Package placement
- Inspection and repair
- Lead-free soldering versus SnPb soldering

### 14.3 Wave soldering

Key characteristics in wave soldering are:

- Process issues, such as application of adhesive and flux, clinching of leads, board transport, the solder wave parameters, and the time during which components are exposed to the wave
- Solder bath specifications, including temperature and impurities

### 14.4 Reflow soldering

Key characteristics in reflow soldering are:

- Lead-free versus SnPb soldering; note that a lead-free reflow process usually leads to higher minimum peak temperatures (see [Figure 19](#)) than a SnPb process, thus reducing the process window
- Solder paste printing issues including smearing, release, and adjusting the process window for a mix of large and small components on one board
- Reflow temperature profile; this profile includes preheat, reflow (in which the board is heated to the peak temperature) and cooling down. It is imperative that the peak temperature is high enough for the solder to make reliable solder joints (a solder paste characteristic). In addition, the peak temperature must be low enough that the packages and/or boards are not damaged. The peak temperature of the package depends on package thickness and volume and is classified in accordance with [Table 7](#) and [8](#)

**Table 7. SnPb eutectic process (from J-STD-020D)**

Package thickness (mm)	Package reflow temperature (°C)	
	Volume (mm <sup>3</sup> )	
	< 350	≥ 350
< 2.5	235	220
≥ 2.5	220	220

**Table 8. Lead-free process (from J-STD-020D)**

Package thickness (mm)	Package reflow temperature (°C)		
	Volume (mm <sup>3</sup> )		
	< 350	350 to 2000	> 2000
< 1.6	260	260	260
1.6 to 2.5	260	250	245
> 2.5	250	245	245

Moisture sensitivity precautions, as indicated on the packing, must be respected at all times.

Studies have shown that small packages reach higher temperatures during reflow soldering, see [Figure 19](#).



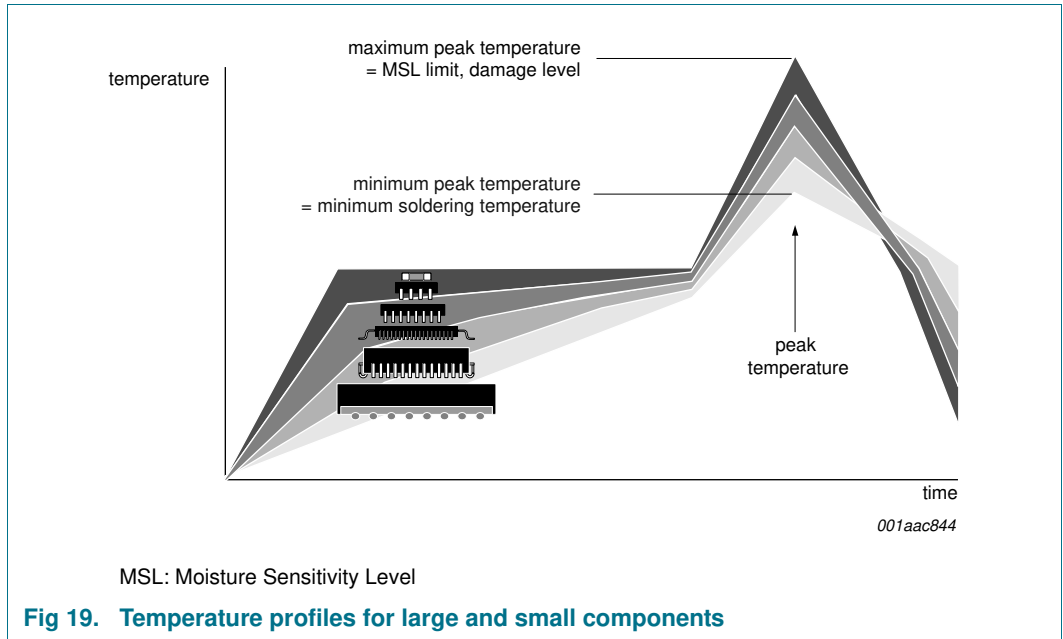

For further information on temperature profiles, refer to Application Note AN10365 “Surface mount reflow soldering description”.

### 15. Soldering: PCB footprints

Footprint information for reflow soldering of TSSOP10 package

SOT552 -1

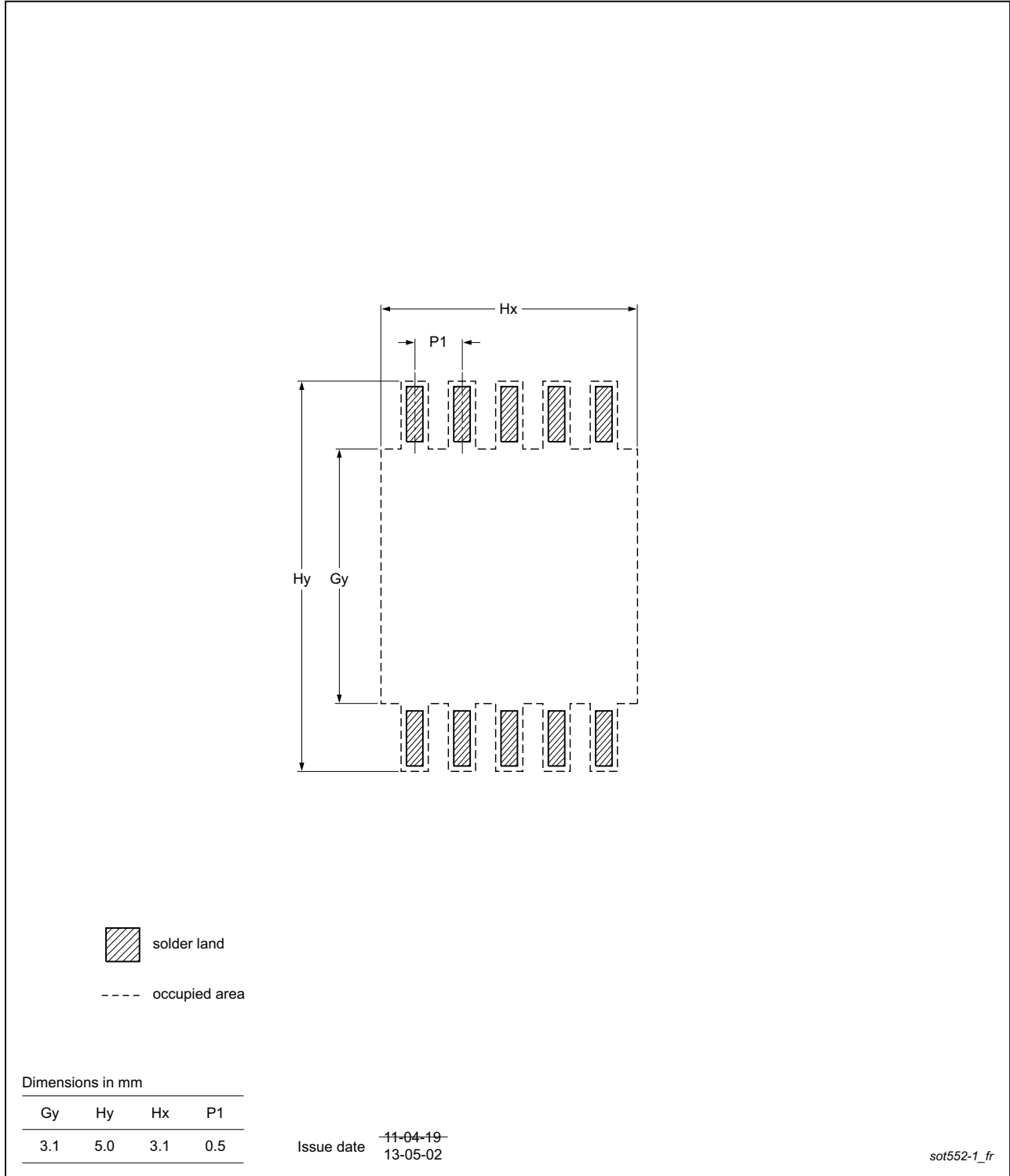

Fig 20. PCB footprint for SOT552-1 (TSSOP10); reflow soldering