



Chipsmall Limited consists of a professional team with an average of over 10 year of expertise in the distribution of electronic components. Based in Hongkong, we have already established firm and mutual-benefit business relationships with customers from,Europe,America and south Asia,supplying obsolete and hard-to-find components to meet their specific needs.

With the principle of “Quality Parts,Customers Priority,Honest Operation,and Considerate Service”,our business mainly focus on the distribution of electronic components. Line cards we deal with include Microchip,ALPS,ROHM,Xilinx,Pulse,ON,Everlight and Freescale. Main products comprise IC,Modules,Potentiometer,IC Socket,Relay,Connector.Our parts cover such applications as commercial,industrial, and automotives areas.

We are looking forward to setting up business relationship with you and hope to provide you with the best service and solution. Let us make a better world for our industry!



Contact us

Tel: +86-755-8981 8866 Fax: +86-755-8427 6832

Email & Skype: info@chipsmall.com Web: www.chipsmall.com

Address: A1208, Overseas Decoration Building, #122 Zhenhua RD., Futian, Shenzhen, China



PCA9901

One wire single LED driver

Rev. 2 — 2 September 2010

Product data sheet

1. General description

The PCA9901 is a 20 mA current source for a single LED that allows stand-alone blinking of a predefined pattern to off-load the microcontroller and save battery power.

Programming of the device is done through a training sequence: the host controller sends the LED lighting sequence and the PCA9901 memorizes it. Once the sequence has been memorized, the PCA9901 can be programmed to send it once or in a loop until the host controller requests the sequence to be stopped.

Commands and blinking sequence are sent through a uni-directional one-wire interface. Commands include: Training Start, Training End, Execute Sequence (once or in loop until a Stop Command is requested) and Reset. A blinking sequence includes up to 3 different blinking patterns, each defined by its ON and OFF timings.

A bypass mode allows the training sequence to be ignored and the LED output to follow the one-wire interface Logic state to directly control the LED from the microcontroller.

An external resistor sets the maximum current that flows in the LED, which can be set between 1 mA and 20 mA.

The PCA9901 operates from a 2.7 V to 5.5 V power supply.

2. Features and benefits

- 1 wire interface to control the device
- Stand-alone blinking capability while training the sequence to blink
- Sequence includes up to 3 blinking elements
- 12-bit (4096 steps) LED ON and OFF timings for each blinking element:
 - ◆ ON timing is captured between 1 ms and 255 ms
 - ◆ OFF timing is captured between 20 ms and 5.1 s
- 1.8 V compliant one-wire logic interface
- Training Start, Training End, Run-Once, Run, Stop and Reset commands
- High side current controlled LED driver with 1 mA to 20 mA max current in the LED set by an external resistor. 5 mA drive capability when no external resistor is connected
- 110 mV max dropout voltage driver at 20 mA
- Fully internal oscillator for sequence training, LED timing, Command and Sequencing Controls
- Short circuit and thermal protection
- 2.7 V to 5.5 V power supply
- Very low quiescent current: < 0.75 μ A



- ESD protection exceeds 2000 V HBM per JESD22-A114, 200 V MM per JESD22-A115, and 1000 V CDM per JESD22-C101
- Latch-up testing is done to JEDEC Standard JESD78, which exceeds 100 mA
- Temperature range: -40 °C to +85 °C
- Packages offered: TSSOP8, WLCSP6

3. Applications

- Cellular telephones
- Stand-alone status indicator

4. Ordering information

Table 1. Ordering information

Type number	Package		
	Name	Description	Version
PCA9901DP	TSSOP8	plastic thin shrink small outline package; 8 leads; body width 3 mm	SOT505-1
PCA9901UK	WLCSP6	wafer level chip-size package; 6 bumps; 1.0 × 1.2 × 0.6 mm	-

4.1 Ordering options

Table 2. Ordering options

Type number	Topside mark	Temperature range
PCA9901DP	9901	-40 °C to +85 °C
PCA9901UK	9901	-40 °C to +85 °C

5. Block diagram

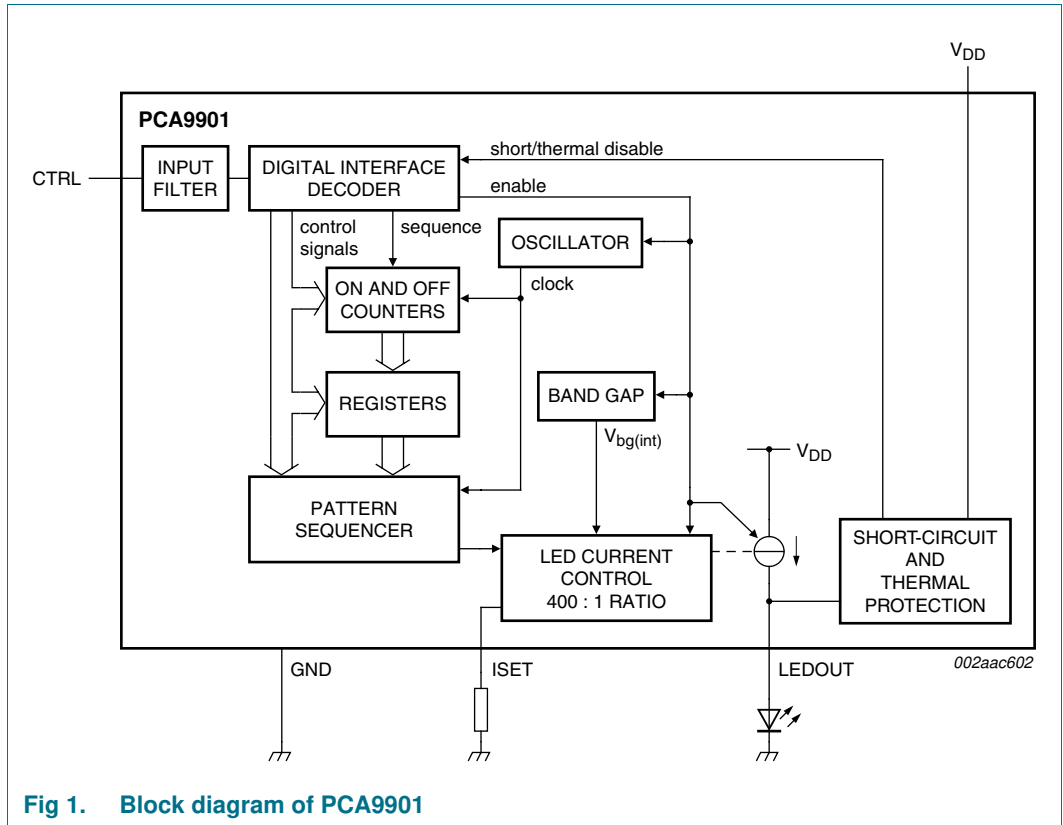
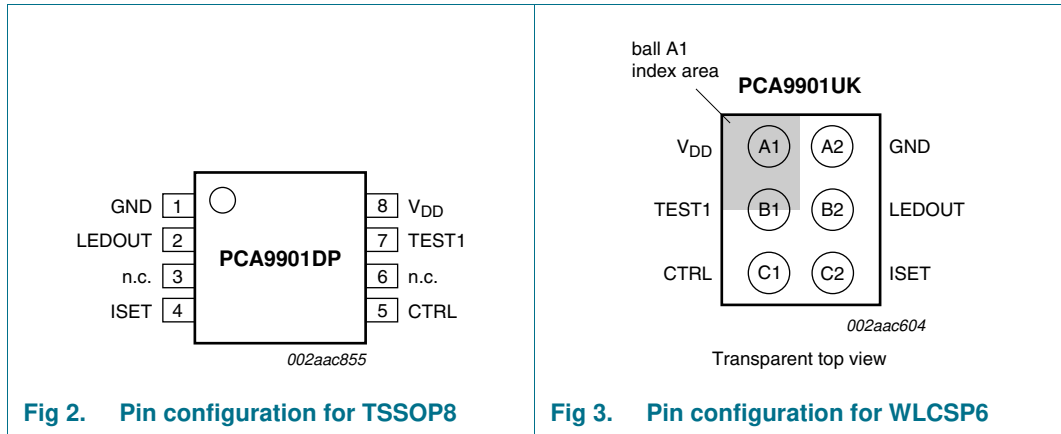

Fig 1. Block diagram of PCA9901

6. Pinning information

6.1 Pinning



6.2 Pin description

Table 3. Pin description

Symbol	Pin		Type	Description
	WLCSP6	TSSOP8		
V _{DD}	A1	8	I	power supply
TEST1	B1	7	I	for test purposes only; must be connected to GND
CTRL	C1	5	I	digital interface
GND	A2	1	I	ground supply
LEDOUT	B2	2	O	LED output (anode LED)
ISET	C2	4	I	current set resistor input; resistor to ground
n.c.	-	3, 6	-	not connected

7. Functional description

Refer to [Figure 1 “Block diagram of PCA9901”](#).

7.1 Digital interface overview - CTRL pin

The digital interface is a simple one-wire uni-directional interface allowing the host controller device to:

- send the lighting sequence to the LEDOUT pin and request the PCA9901 to capture and memorize it at the same time
- send the specific commands to execute the captured and memorized sequence later
- reset the PCA9901 to a known state at any time.

The lighting sequence to be captured by the PCA9901 contains the actual LED ON (CTRL = 1) and LED OFF (CTRL = 0) timings. A sequence includes up to 3 different patterns, each one containing one ON and one OFF value. Up to 3 LED ON and 3 LED OFF times can then be memorized by the PCA9901.

Commands are specific events that tell the PCA9901 what action needs to be performed. The different commands are:

TRAINING START: Beginning of the training sequence. Upon reception of this command, the PCA9901 starts capturing the lighting sequence.

TRAINING END: End of the training sequence. Upon reception of this command, the capture stops, and the sequence is stored in the corresponding registers. The PCA9901 goes to Shutdown mode.

RUN ONCE: The sequence that has been memorized is executed once and then the PCA9901 goes to Shutdown mode. If no sequence has been previously captured, the PCA9901 goes to Shutdown mode.

RUN: The sequence that has been memorized is executed until a STOP Command occurs.

STOP: The LED output is switched off at the end of the current LED ON time and the PCA9901 goes to Shutdown mode.

RESET: The PCA9901 is reset and all the internal registers default to zeroes. The PCA9901 goes to Shutdown mode.

The PCA9901 decodes the commands using a 1.5 ms window from the first LOW to HIGH transition that occurs on the CTRL pin. The following command or the data following a command must then be issued at least 1.5 ms after.

At the end of the 1.5 ms window:

- The PCA9901 is fully operational (in the case the command is issued while the PCA9901 was in Shutdown mode)
- The command has been successfully decoded and the PCA9901 is ready for the next message from the host controller (which will start at the next LOW to HIGH transition on the CTRL pin), or is ready to execute the required command.

7.2 Command descriptions

7.2.1 TRAINING START command

2 pulses sent to the PCA9901 in less than 1.5 ms causes the PCA9901 to enter the Training mode.

The PCA9901 leaves the Shutdown mode as soon as the first rising edge is detected, resets its registers to zeroes and is ready for sequence capture within the 1.5 ms.

The next assertion of the CTRL pin (LOW to HIGH transition) starts the first LED ON period capture. CTRL cannot be asserted in less than 1.5 ms after the TRAINING START command has been issued.

7.2.2 TRAINING END command

3 pulses sent to the PCA9901 in less than 1.5 ms causes the PCA9901 to leave the Training mode.

The PCA9901 ends the last LED OFF period capture when the TRAINING END command occurs.

The PCA9901 goes to Shutdown mode.

7.2.3 RUN ONCE command

4 pulses sent to the PCA9901 in less than 1.5 ms causes the device to enter the RUN ONCE mode and wait for a 'synchronization' rising edge on CTRL.

When a rising edge on CTRL is detected, the sequence that has been previously captured is run once. If no sequence has been captured it will go into Shutdown mode.

Once the sequence has been run, the PCA9901 goes to Shutdown mode.

Remark: CTRL line may stay either HIGH or LOW after the 'synchronization' edge.

7.2.4 RUN command

A LOW to HIGH transition followed by a HIGH state longer than 1.5 ms causes the sequence that has been previously captured to be executed in loop. The CTRL pin stays HIGH as long as the sequence is executed. If no sequence has been captured it will go into Shutdown mode.

7.2.5 STOP command

A HIGH to LOW transition when the PCA9901 is in the RUN mode causes the sequence that is running to stop:

- Immediately, if the transition occurred during the LED OFF time
- After finishing the execution of the current LED ON cycle if the transition occurred during the LED ON time.

Once the sequence has been stopped, the PCA9901 goes to Shutdown mode.

7.2.6 RESET command

A single pulse sent to the PCA9901 in less than 1.5 ms causes the PCA9901 to go to Shutdown mode and to reset its registers to zeroes.

7.3 State machine

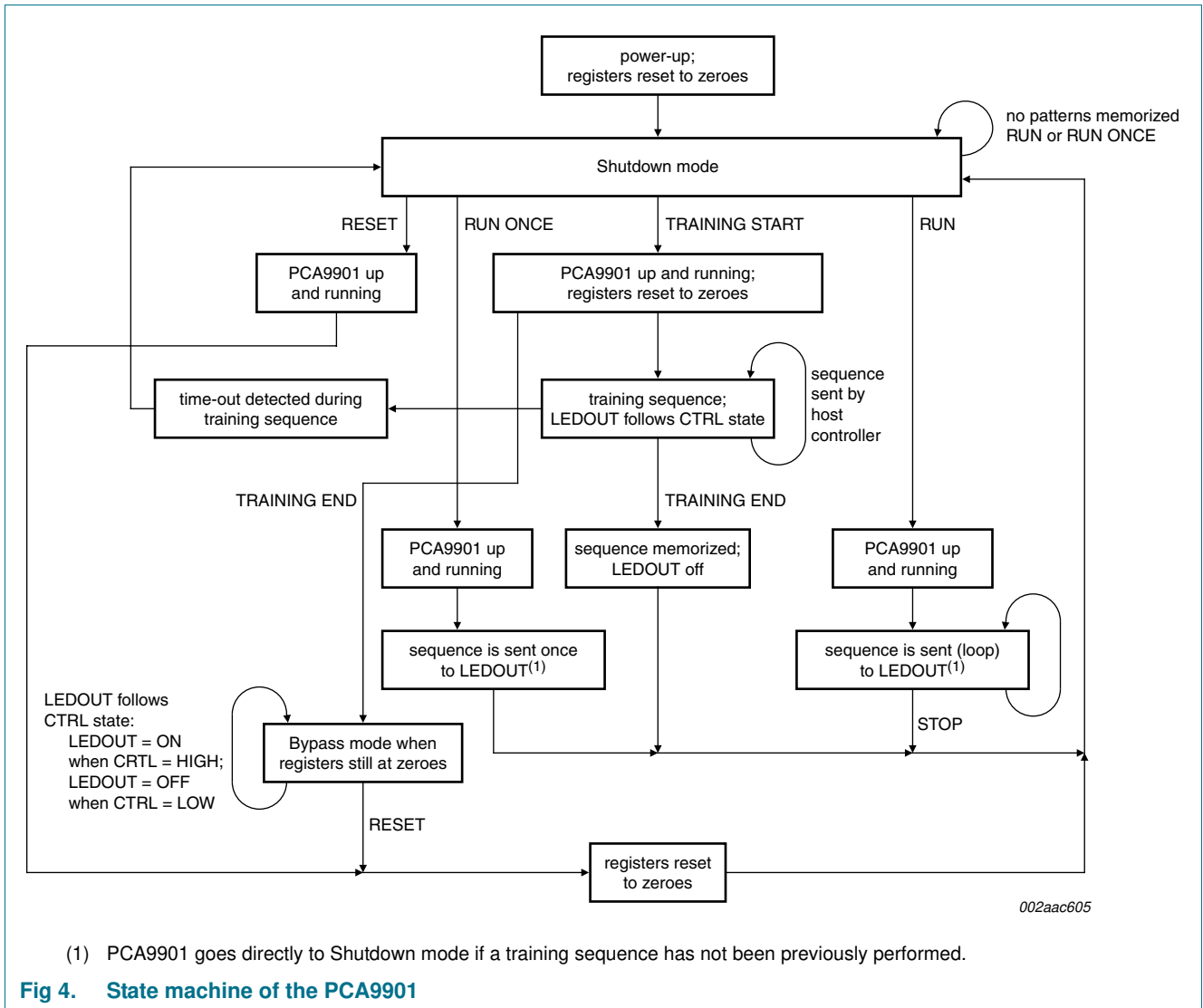

Fig 4. State machine of the PCA9901

7.4 Lighting training sequence

Training sequence starts after a TRAINING START command has been issued by the host controller and ends after a TRAINING END command has been issued.

The LED ON timing is provided when CTRL is HIGH and the LED OFF timing is provided when CTRL is LOW.

LEDOUT follows CTRL Logic state during the Training sequence: The LED is ON when CTRL = HIGH, and the LED is OFF when CTRL = LOW.

The sequence is as follows:

Pattern 1 ON – Pattern 1 OFF – Pattern 2 ON – Pattern 2 OFF – Pattern 3 ON – Pattern 3 OFF

A sequence composed by only 1 or 2 patterns can also be stored by issuing the TRAINING END command after either the first or the second pattern. Non-programmed registers during the training sequence remain programmed with zeroes; when the state machine encounters a Zero ON time register, it loops to the beginning of the sequence.

- LED ON timing: 1 ms step with a 12-bit resolution – Time between 1 ms and at least 255 ms.
An ON time higher than 255 ms causes the ON counter to saturate at max value (0xFF).
- LED OFF timing: 20 ms step with a 12-bit resolution – Time between at least 20 ms and 5.1 s.
An OFF time higher than 5.1 s causes the OFF counter to saturate at max value (0xFF).

ON and OFF timings are stored on the 8-bit registers. The registers are reset to zeroes when the host controller sends a TRAINING START or RESET command.

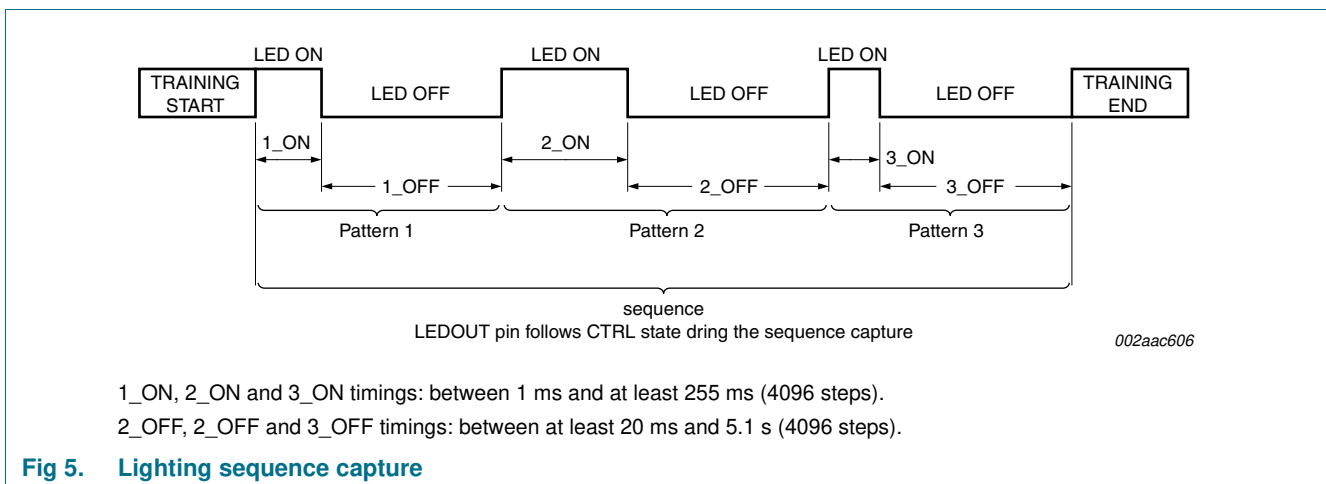

7.5 TRAINING START and TRAINING END commands waveforms

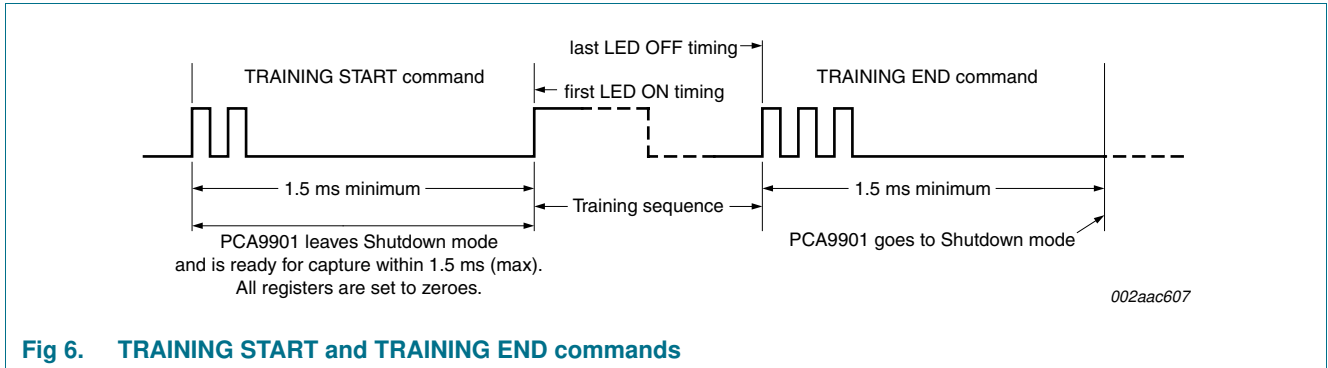

Fig 6. TRAINING START and TRAINING END commands

7.6 RUN ONCE, RUN, STOP and RESET commands waveforms

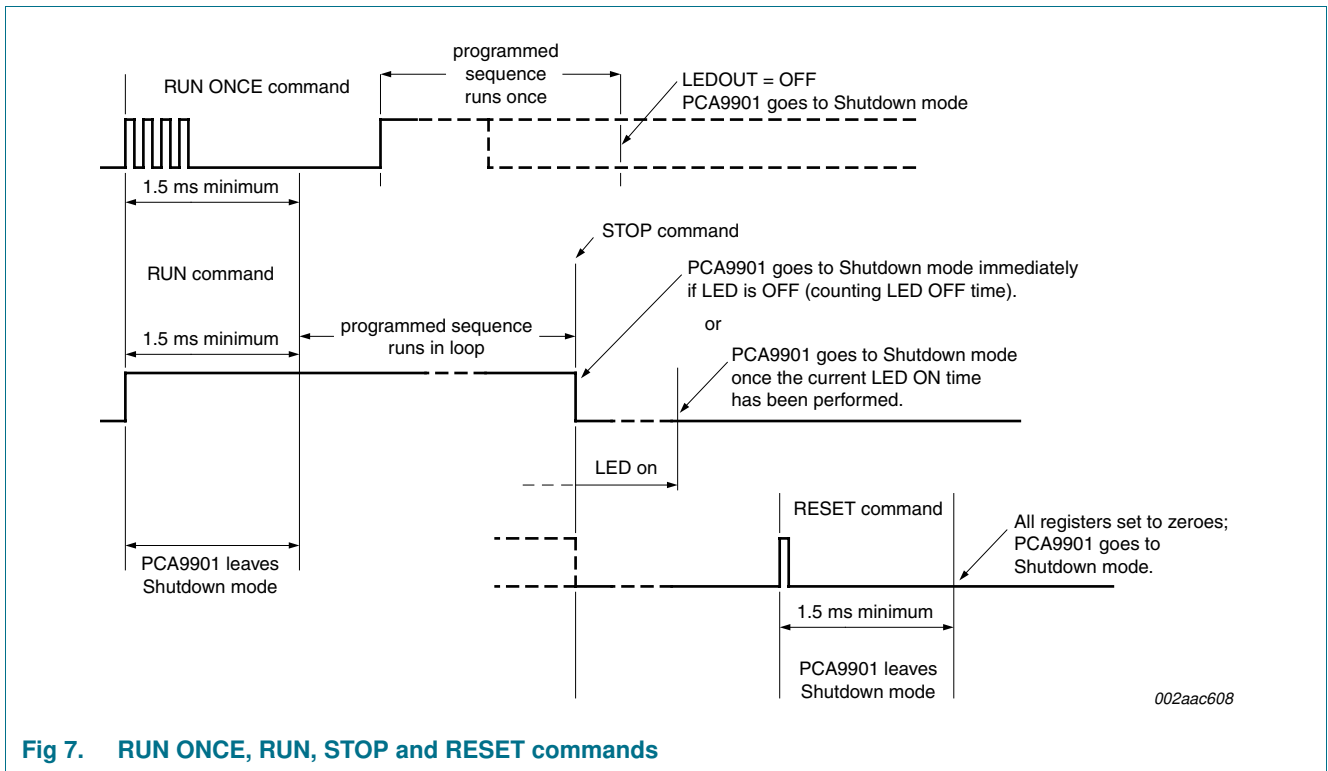

Fig 7. RUN ONCE, RUN, STOP and RESET commands

7.7 Bypass mode

A Bypass mode allows the PCA9901 LEDOUT pin to be directly driven by the CTRL logic state.

A TRAINING START command followed immediately by a TRAINING END command enters the Bypass mode. Once the TRAINING END command has been issued, the LEDOUT output follows the CTRL logic state (LED ON when CTRL = HIGH, LED OFF when CTRL = 0). Sending a RESET command exits the Bypass mode.

The Bypass mode allows the microcontroller to directly control the LED and blink it or dim it.

7.8 Time-out

The time-out circuitry allows the PCA9901 to be safely set back to the Shutdown mode when a communication problem occurs between the host controller and the PCA9901.

7.8.1 CTRL LOW too long after receiving a TRAINING START command

The PCA9901 is waiting for the first LED ON timing.

1. Once the TRAINING START command has been decoded (end of the 1.5 ms window), a time-out counter starts counting as long as CTRL stays LOW.
2. The time-out counter counts until it reaches the maximum allowed ON value. The maximum allowed ON time is greater than or equal to 255 ms.

Remark: If CTRL goes HIGH before reaching the maximum counter value, the time-out counter is reset and the PCA9901 starts counting the LED ON timing or decoding the command that has been issued.

3. If the maximum time-out value is reached, the training sequence is automatically terminated and the PCA9901 goes to Shutdown mode.

Remark: When the time-out occurs and the PCA9901 goes to Shutdown mode, the registers are still programmed with zeroes.

7.8.2 CTRL HIGH too long during the training sequence

The PCA9901 is counting the ON timing and reaches the counter maximum value (0xFF). If CTRL does not go LOW when reaching the max value:

1. The PCA9901 switches off the LEDOUT pin.
2. Maximum ON count is stored in the corresponding ON register.
3. A time-out counter starts counting until it reaches the maximum allowed OFF value. The maximum allowed OFF time is greater than or equal to 5.11 seconds.
4. When the maximum time-out counter value is reached, maximum OFF count is stored in the corresponding OFF register.

Remark: If CTRL goes LOW before reaching the maximum counter value, the time-out counter is reset and the PCA9901 starts counting the LED OFF timing.

5. If the maximum time-out value is reached, the training sequence is automatically terminated and the PCA9901 goes to Shutdown mode.

7.8.3 CTRL LOW too long during the training sequence

The PCA9901 is counting the OFF timing and reaches the counter maximum value (0xFF). If CTRL does not go HIGH when reaching the maximum value:

1. Maximum OFF count is stored in the corresponding OFF register.
2. A time-out counter starts counting until it reaches the maximum allowed OFF value. The maximum allowed OFF time is greater than or equal to 5.11 seconds.
3. When the maximum time-out counter value is reached, the training sequence is automatically terminated and the PCA9901 goes to Shutdown mode.

Remark: If CTRL goes HIGH before reaching the maximum counter value, the time-out counter is reset and the PCA9901 starts counting the LED ON timing or decoding the command that has been issued.

7.8.4 'Synchronization' signal not generated after RUN ONCE command

The PCA9901 is waiting for the 'Synchronization' signal (rising edge of CTRL) after a RUN ONCE command has been issued.

1. Once the RUN ONCE command has been decoded (end of the 1.5 ms window), a time-out counter starts counting as long as CTRL stays LOW.
2. The time-out counter counts until it reaches the maximum allowed ON value. The maximum allowed ON time is greater than or equal to 255 ms.
Remark: If CTRL goes HIGH before reaching the maximum counter value, the time-out counter is reset and the PCA9901 runs the sequence once.
3. If the maximum time-out value is reached, the RUN ONCE command is automatically aborted and the PCA9901 goes to Shutdown mode.

7.9 Current source generation

The LED output contains a constant current driver that will source a current that is determined by an external resistor connected between ISET pin and GND. The current can be set using the following formula:

$$I_O = \frac{(1.23 \times 400)}{R_{ext}} \quad (1)$$

R_{ext} can be chosen so that a maximum LED current value between 1 mA and 20 mA can be programmed.

Remark: LED current accuracy is proportional to the accuracy and temperature coefficient tolerance of R_{ext} .

When no external resistor is connected between the ISET pin and GND, the LED output is able to source 5 mA through a fully internal current source. It is automatically shut down when an external resistor is connected to ISET.

Remark: The LED current accuracy is proportional to the tolerance and temperature coefficient of the resistor.

Remark: To save power, the current source generator is only enabled when the LED needs to be turned on.

7.10 Short-circuit and thermal protection

A short-circuit and thermal protection circuitry disables the LED output driver and the current generator when a short occurs or when a high temperature condition has been detected.

The circuitry is active during normal mode operation (Programming, RUN ONCE, RUN or Bypass modes). When a fault condition is detected, the reference current circuitry (ISET) and the LED output stage (LEDOUT) are automatically shut down. This will cause LEDOUT to be OFF as long as the fault condition is present. The other analog blocks (oscillator, voltage reference) are kept enabled as long as the PCA9901 is in normal mode operation.

The PCA9901 goes automatically to Power-down mode when it exits the programming, RUN ONCE, RUN or Bypass modes.

If the fault condition goes away during normal mode operation, the reference current circuitry and the LED output stage are again enabled, allowing the PCA9901 to resume control of the LED output stage (LEDOUT).

A short-circuit condition is detected when the PCA9901's current consumption becomes higher than 50 mA.

An overtemperature condition is detected when the temperature goes above 125 °C. It goes away when the temperature goes 15 °C below the overtemperature condition.

7.11 Shutdown mode

Shutdown mode is the low power mode where the internal oscillator, band gap, current generator and LED driver are turned off to save power, and is the default mode at power-up.

Shutdown mode is automatically entered after:

- A RUN ONCE sequence has been executed
- A STOP command
- A TRAINING END command
- A RESET command
- A Time-out condition has been detected.

When in Shutdown mode, setting CTRL HIGH immediately exits the Shutdown mode: the oscillator and the band gap are turned on and it takes up to 1.5 ms for the device to be up and running and decode the command issued by the host controller.

7.12 Reset

Reset mode is achieved by sending a RESET command and causes all the registers to be reset to zeroes and the device to go to Shutdown mode.

8. Application design-in information

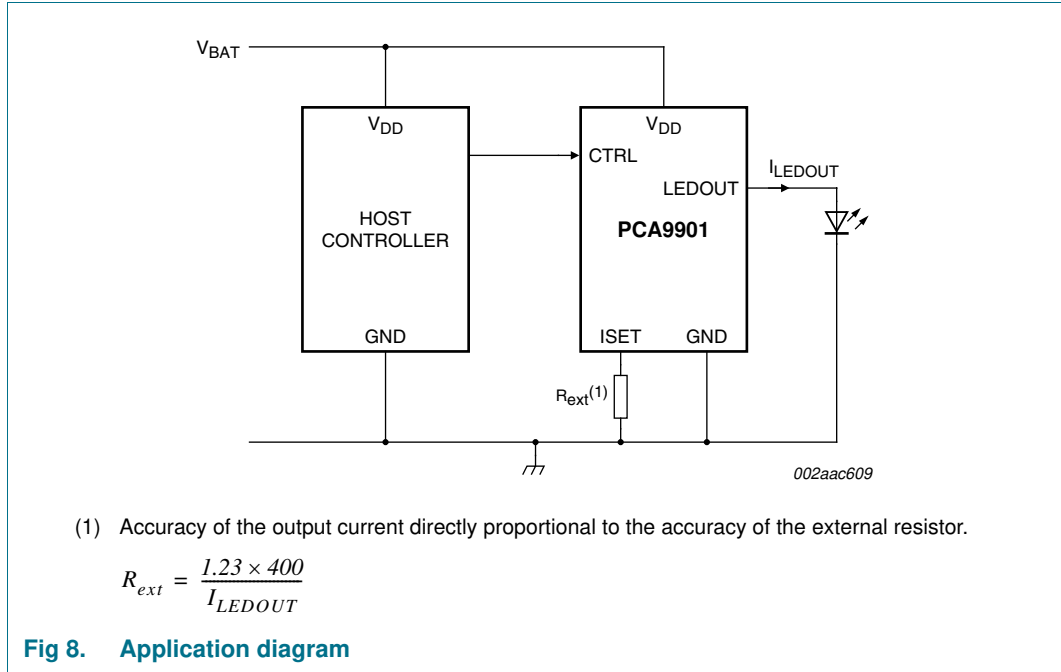

9. Limiting values

Table 4. Limiting values

In accordance with the Absolute Maximum Rating System (IEC 60134).

Symbol	Parameter	Conditions	Min	Max	Unit
V _{DD}	supply voltage		-0.3	+6.0	V
V _I	input voltage	CTRL pin	-0.3	V _{DD} + 0.2	V
		ISET pin	-0.3	V _{DD} + 0.2	V
I _I	input current	ISET	-	125	μA
I _O	output current	LEDOUT	-	50	mA
		ISET	-	125	μA
T _{stg}	storage temperature		-65	+150	°C
T _{amb}	ambient temperature	operating	-40	+85	°C
V _{ESD}	electrostatic discharge voltage	HBM	-2000	+2000	V
		MM	-200	+200	V
		CDM	-500	+500	V
V _{ESD(LEDOUT)}	electrostatic discharge voltage on pin LEDOUT	HBM	[1] -2000	+2000	V

[1] ESD rating on that specific pin may be higher. Will be updated if needed when device available and ESD test performed.

10. Static characteristics

Table 5. Static characteristics

$V_{DD} = 2.7\text{ V to }5.5\text{ V}$; $T_{amb} = -40\text{ }^{\circ}\text{C to }+85\text{ }^{\circ}\text{C}$; unless otherwise specified.

Symbol	Parameter	Conditions	Min	Typ	Max	Unit
Supply						
V_{DD}	supply voltage		2.7	3.3	5.5	V
I_{DD}	supply current	$V_{DD} = 3.3\text{ V}$; CTRL = GND; LEDOUT = 0 mA; excludes LED drive and current mirror currents	-	-	40	μA
$I_{DD(sd)}$	shutdown mode supply current		-	0.3	0.75	μA
$I_{th(det)sc}$	short-circuit detection threshold current	maximum current before short detected; guaranteed by design	-	50	70	mA
$\Delta I_O / (I_O \times \Delta V_I)$	line regulation	LEDOUT enabled	-	-	2	% / V
V_{POR}	power-on reset voltage	rising power supply	-	2.0	2.5	V
LEDOUT pin						
V_{do}	dropout voltage	when LED current dropped 10 % from the nominal current value				
		$I_{LEDOUT} = 5\text{ mA}$	-	-	30	mV
		$I_{LEDOUT} = 10\text{ mA}$	-	40	50	mV
		$I_{LEDOUT} = 20\text{ mA}$	-	75	110	mV
V_{LEDOUT}	voltage on pin LEDOUT		1.2	-	3.1	V
I_{LEDOUT}	current on pin LEDOUT	with external resistor	1	-	20	mA
		without external resistor	-	5	-	mA
$\Delta I_O / I_O$	relative output current variation	symmetrical (peak-to-peak); must not offset average current setting	-	-	5	%
$\Delta I_{LEDOUT} / I_{LEDOUT}$	relative current variation on pin LEDOUT	current load regulation				
		overtemperature and LED V_F change from 1.2 V to V_{DD} with external resistor	-10	-	+10	%
		overtemperature and LED V_F change from 1.2 V to V_{do} with external resistor	-30	-	+30	%
		overtemperature and LED V_F change from 1.2 V to 3.1 V without external resistor	-30	-	+30	%
CTRL pin						
V_{IL}	LOW-level input voltage		-	-	0.4	V
V_{IH}	HIGH-level input voltage		1.2	-	-	V
I_{IH}	HIGH-level input current		-	-	1	μA
I_{LI}	input leakage current		-1	-	-	μA
C_i	input capacitance	$V_I = V_{SS}$ or V_{DD}	-	-	5	pF

Table 5. Static characteristics ...continued $V_{DD} = 2.7\text{ V to }5.5\text{ V}$; $T_{amb} = -40\text{ }^{\circ}\text{C to }+85\text{ }^{\circ}\text{C}$; unless otherwise specified.

Symbol	Parameter	Conditions	Min	Typ	Max	Unit
ISET pin						
V_{ISET}	voltage on pin ISET		-	1.23	-	V
$\Delta V_{ISET}/V_{ISET}$	relative voltage variation on pin ISET	$I_{LEDOUT} = 5\text{ mA to }20\text{ mA}$	-10	-	+10	%
$\Delta I_{O}/I_{exp}$	output current variation to expected current ratio	linearity of $I_{LED} / ISET$ function	-2	-	2	%
I_{LED}/I_{ISET}	LED current to ISET current ratio	$I_{LEDOUT} = 5\text{ mA to }20\text{ mA}$	-	400	-	
Thermal shutdown						
T_{sd}	shutdown temperature	guaranteed by design	-	125	-	$^{\circ}\text{C}$
$T_{sd(hys)}$	hysteresis of shutdown temperature	guaranteed by design	-	15	-	$^{\circ}\text{C}$

11. Dynamic characteristics

Table 6. Dynamic characteristics $V_{DD} = 2.7\text{ V to }5.5\text{ V}$; $T_{amb} = -40\text{ }^{\circ}\text{C to }85\text{ }^{\circ}\text{C}$; unless otherwise specified.

Symbol	Parameter	Conditions	Min	Typ	Max	Unit
CTRL pin						
$t_{WH(CTRL)}$	pulse width HIGH on pin CTRL	command pulse ON	2	-	50	μs
$t_{WL(CTRL)}$	pulse width LOW on pin CTRL	command pulse OFF	2	-	75	μs
$t_{decod(cmd)}$	command decode time		-	1.5	-	ms
$t_{w(spike)}$	spike pulse width		-	25	-	ns
LEDOUT pin						
$t_{WH(LEDOUT)}$	pulse width HIGH on pin LEDOUT	minimum LED ON period	[1]	1	$\pm 1\%$	ms
$t_{WL(LEDOUT)}$	pulse width LOW on pin LEDOUT	minimum LED OFF period	[2]	20	$\pm 1\%$	ms
ΔT_{LED}	LED period variation	internal oscillator clock cycle	-200	-	+200	μs
Oscillator						
$\Delta f_{osc}/f_{osc}$	relative oscillator frequency variation	over temperature; guaranteed by design	-	5	-	%

[1] LED ON-time resolution.

[2] LED OFF-time resolution.

12. Tape and reel information

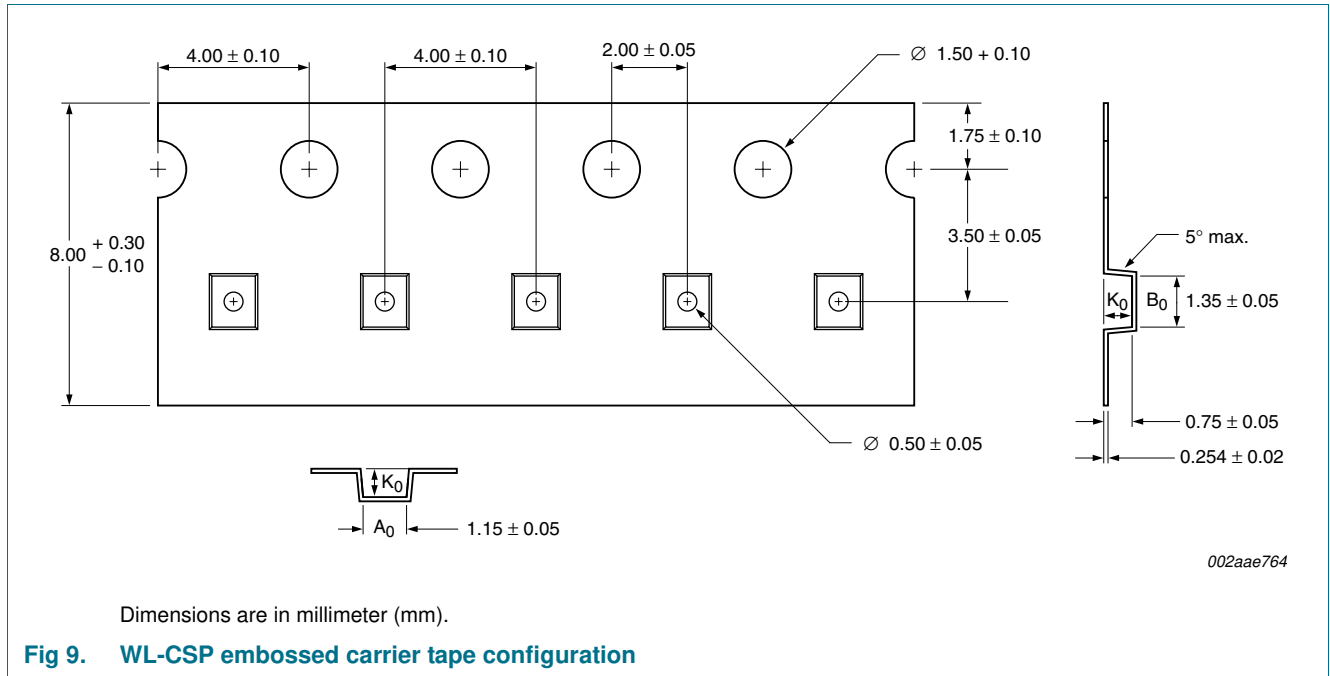

13. Package outline

TSSOP8: plastic thin shrink small outline package; 8 leads; body width 3 mm

SOT505-1

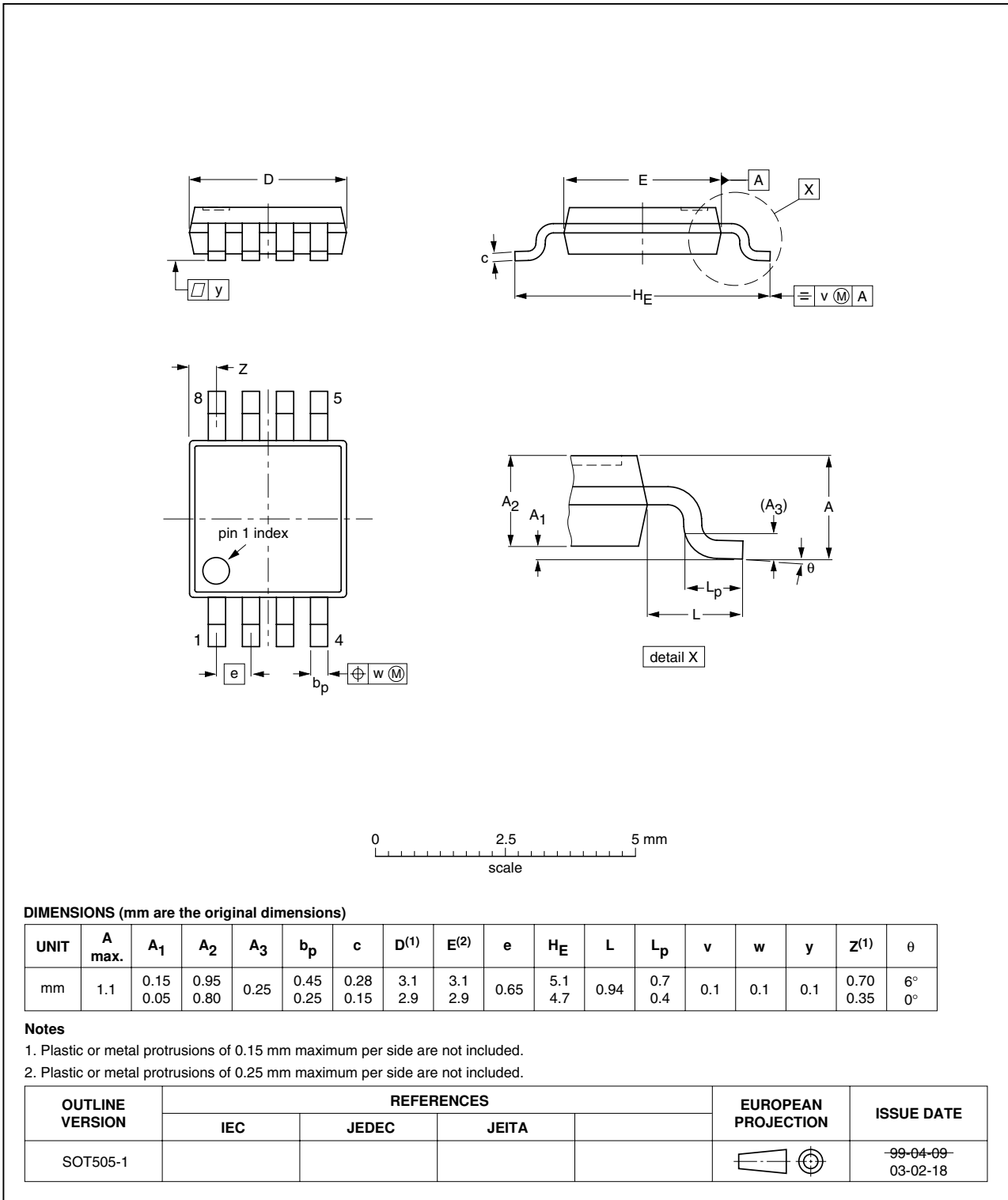

Fig 10. Package outline SOT505-1 (TSSOP8)

WLCSP6: wafer level chip-size package; 6 bumps; 1.0 x 1.2 x 0.6 mm

PCA9901UK

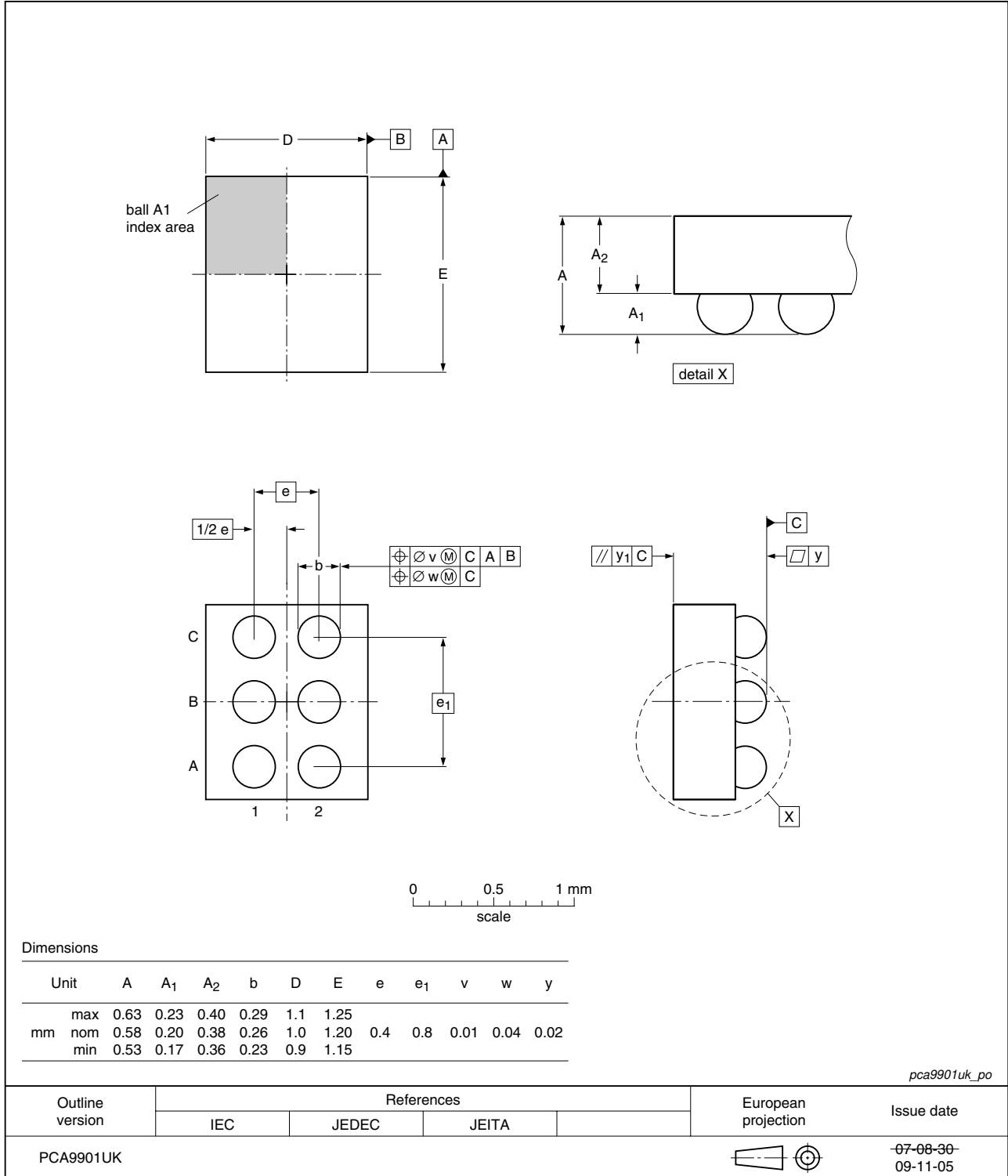

Fig 11. Package outline PCA9901UK (WLCSP6)

14. Soldering of SMD packages

This text provides a very brief insight into a complex technology. A more in-depth account of soldering ICs can be found in Application Note *AN10365 "Surface mount reflow soldering description"*.

14.1 Introduction to soldering

Soldering is one of the most common methods through which packages are attached to Printed Circuit Boards (PCBs), to form electrical circuits. The soldered joint provides both the mechanical and the electrical connection. There is no single soldering method that is ideal for all IC packages. Wave soldering is often preferred when through-hole and Surface Mount Devices (SMDs) are mixed on one printed wiring board; however, it is not suitable for fine pitch SMDs. Reflow soldering is ideal for the small pitches and high densities that come with increased miniaturization.

14.2 Wave and reflow soldering

Wave soldering is a joining technology in which the joints are made by solder coming from a standing wave of liquid solder. The wave soldering process is suitable for the following:

- Through-hole components
- Leaded or leadless SMDs, which are glued to the surface of the printed circuit board

Not all SMDs can be wave soldered. Packages with solder balls, and some leadless packages which have solder lands underneath the body, cannot be wave soldered. Also, leaded SMDs with leads having a pitch smaller than ~0.6 mm cannot be wave soldered, due to an increased probability of bridging.

The reflow soldering process involves applying solder paste to a board, followed by component placement and exposure to a temperature profile. Leaded packages, packages with solder balls, and leadless packages are all reflow solderable.

Key characteristics in both wave and reflow soldering are:

- Board specifications, including the board finish, solder masks and vias
- Package footprints, including solder thieves and orientation
- The moisture sensitivity level of the packages
- Package placement
- Inspection and repair
- Lead-free soldering versus SnPb soldering

14.3 Wave soldering

Key characteristics in wave soldering are:

- Process issues, such as application of adhesive and flux, clinching of leads, board transport, the solder wave parameters, and the time during which components are exposed to the wave
- Solder bath specifications, including temperature and impurities

14.4 Reflow soldering

Key characteristics in reflow soldering are:

- Lead-free versus SnPb soldering; note that a lead-free reflow process usually leads to higher minimum peak temperatures (see [Figure 12](#)) than a SnPb process, thus reducing the process window
- Solder paste printing issues including smearing, release, and adjusting the process window for a mix of large and small components on one board
- Reflow temperature profile; this profile includes preheat, reflow (in which the board is heated to the peak temperature) and cooling down. It is imperative that the peak temperature is high enough for the solder to make reliable solder joints (a solder paste characteristic). In addition, the peak temperature must be low enough that the packages and/or boards are not damaged. The peak temperature of the package depends on package thickness and volume and is classified in accordance with [Table 7](#) and [8](#)

Table 7. SnPb eutectic process (from J-STD-020C)

Package thickness (mm)	Package reflow temperature (°C)	
	Volume (mm ³)	
	< 350	≥ 350
< 2.5	235	220
≥ 2.5	220	220

Table 8. Lead-free process (from J-STD-020C)

Package thickness (mm)	Package reflow temperature (°C)		
	Volume (mm ³)		
	< 350	350 to 2000	> 2000
< 1.6	260	260	260
1.6 to 2.5	260	250	245
> 2.5	250	245	245

Moisture sensitivity precautions, as indicated on the packing, must be respected at all times.

Studies have shown that small packages reach higher temperatures during reflow soldering, see [Figure 12](#).

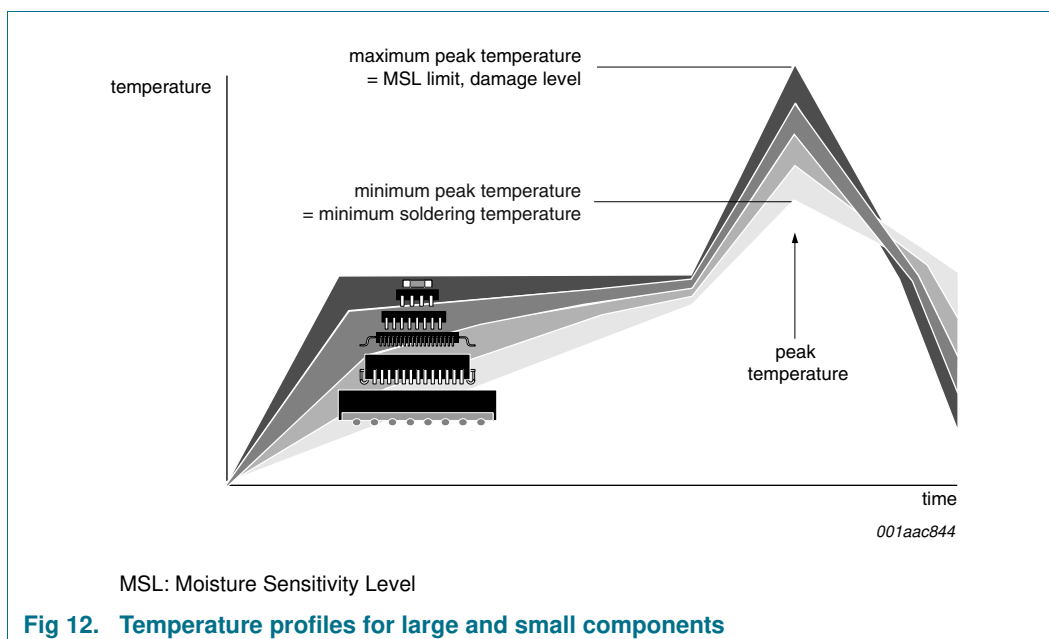

For further information on temperature profiles, refer to Application Note *AN10365 "Surface mount reflow soldering description"*.

15. Soldering of WLCSP packages

15.1 Introduction to soldering WLCSP packages

This text provides a very brief insight into a complex technology. A more in-depth account of soldering WLCSP (Wafer Level Chip-Size Packages) can be found in application note *AN10439 "Wafer Level Chip Scale Package"* and in application note *AN10365 "Surface mount reflow soldering description"*.

Wave soldering is not suitable for this package.

All NXP WLCSP packages are lead-free.

15.2 Board mounting

Board mounting of a WLCSP requires several steps:

1. Solder paste printing on the PCB
2. Component placement with a pick and place machine
3. The reflow soldering itself

15.3 Reflow soldering

Key characteristics in reflow soldering are:

- Lead-free versus SnPb soldering; note that a lead-free reflow process usually leads to higher minimum peak temperatures (see [Figure 13](#)) than a PbSn process, thus reducing the process window

- Solder paste printing issues, such as smearing, release, and adjusting the process window for a mix of large and small components on one board
- Reflow temperature profile; this profile includes preheat, reflow (in which the board is heated to the peak temperature), and cooling down. It is imperative that the peak temperature is high enough for the solder to make reliable solder joints (a solder paste characteristic) while being low enough that the packages and/or boards are not damaged. The peak temperature of the package depends on package thickness and volume and is classified in accordance with [Table 9](#).

Table 9. Lead-free process (from J-STD-020C)

Package thickness (mm)	Package reflow temperature (°C)		
	Volume (mm ³)		
	< 350	350 to 2000	> 2000
< 1.6	260	260	260
1.6 to 2.5	260	250	245
> 2.5	250	245	245

Moisture sensitivity precautions, as indicated on the packing, must be respected at all times.

Studies have shown that small packages reach higher temperatures during reflow soldering, see [Figure 13](#).

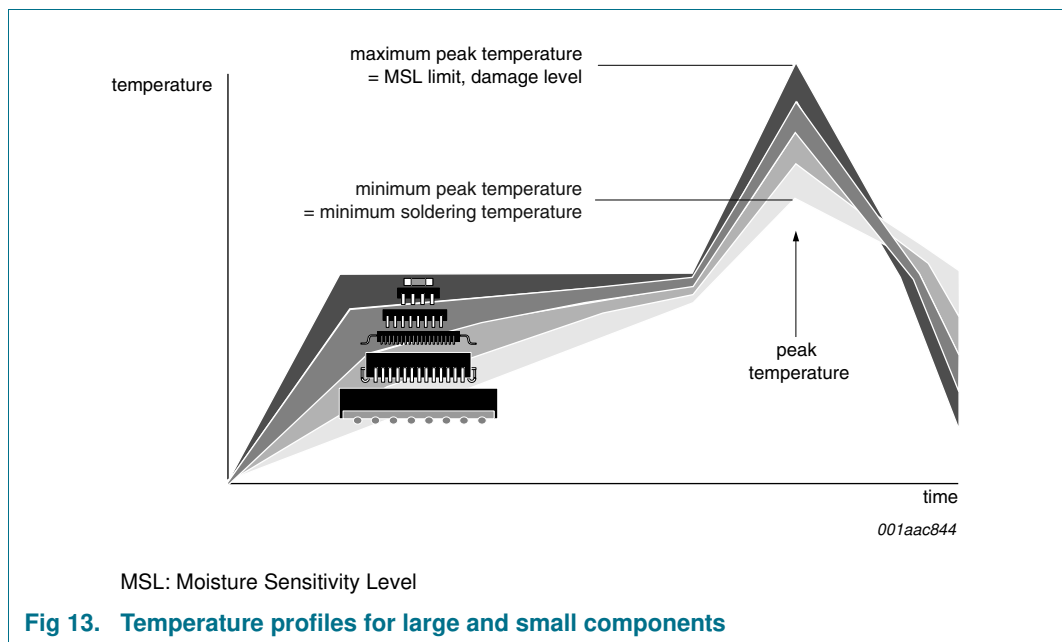

For further information on temperature profiles, refer to application note *AN10365 "Surface mount reflow soldering description"*.

15.3.1 Stand off

The stand off between the substrate and the chip is determined by:

- The amount of printed solder on the substrate
- The size of the solder land on the substrate

- The bump height on the chip

The higher the stand off, the better the stresses are released due to TEC (Thermal Expansion Coefficient) differences between substrate and chip.

15.3.2 Quality of solder joint

A flip-chip joint is considered to be a good joint when the entire solder land has been wetted by the solder from the bump. The surface of the joint should be smooth and the shape symmetrical. The soldered joints on a chip should be uniform. Voids in the bumps after reflow can occur during the reflow process in bumps with high ratio of bump diameter to bump height, i.e. low bumps with large diameter. No failures have been found to be related to these voids. Solder joint inspection after reflow can be done with X-ray to monitor defects such as bridging, open circuits and voids.

15.3.3 Rework

In general, rework is not recommended. By rework we mean the process of removing the chip from the substrate and replacing it with a new chip. If a chip is removed from the substrate, most solder balls of the chip will be damaged. In that case it is recommended not to re-use the chip again.

Device removal can be done when the substrate is heated until it is certain that all solder joints are molten. The chip can then be carefully removed from the substrate without damaging the tracks and solder lands on the substrate. Removing the device must be done using plastic tweezers, because metal tweezers can damage the silicon. The surface of the substrate should be carefully cleaned and all solder and flux residues and/or underfill removed. When a new chip is placed on the substrate, use the flux process instead of solder on the solder lands. Apply flux on the bumps at the chip side as well as on the solder pads on the substrate. Place and align the new chip while viewing with a microscope. To reflow the solder, use the solder profile shown in application note AN10365 "Surface mount reflow soldering description".

15.3.4 Cleaning

Cleaning can be done after reflow soldering.

16. Abbreviations

Table 10. Abbreviations

Acronym	Description
CDM	Charged Device Model
ESD	ElectroStatic Discharge
GPRS	Global Packet Radio System
GSM	Global System for Mobile communications
HBM	Human Body Model
LED	Light Emitting Diode
MM	Machine Model
PWB	Printed Wiring Board

17. Revision history

Table 11. Revision history

Document ID	Release date	Data sheet status	Change notice	Supersedes
PCA9901 v.2	20100902	Product data sheet	-	PCA9901 v.1
Modifications	<ul style="list-style-type: none"> • Table 1 “Ordering information”: Removed type number PCA9901GD (row) • Table 2 “Ordering options”: <ul style="list-style-type: none"> – Removed PCA9901GD – Changed Topside mark for PCA9901UK from “P01” to “9901” • Removed (old) Section 5, “Marking” • Section 6.1 “Pinning”: removed (old) “Figure 4, Pin configuration for XSON8U” • Table 5 “Static characteristics”: <ul style="list-style-type: none"> – Typical value for V_{POR} corrected from “1.8 V” to “2.0 V”. – Maximum value for V_{POR} corrected from “2.0 V” to “2.5 V”. • Section 13 “Package outline”: removed (old) Figure 13, “Package outline SOT996-2 (XSON8U)” 			
PCA9901 v.1	20091203	Product data sheet	-	-

18. Legal information

18.1 Data sheet status

Document status ^{[1][2]}	Product status ^[3]	Definition
Objective [short] data sheet	Development	This document contains data from the objective specification for product development.
Preliminary [short] data sheet	Qualification	This document contains data from the preliminary specification.
Product [short] data sheet	Production	This document contains the product specification.

[1] Please consult the most recently issued document before initiating or completing a design.

[2] The term 'short data sheet' is explained in section "Definitions".

[3] The product status of device(s) described in this document may have changed since this document was published and may differ in case of multiple devices. The latest product status information is available on the Internet at URL <http://www.nxp.com>.

18.2 Definitions

Draft — The document is a draft version only. The content is still under internal review and subject to formal approval, which may result in modifications or additions. NXP Semiconductors does not give any representations or warranties as to the accuracy or completeness of information included herein and shall have no liability for the consequences of use of such information.

Short data sheet — A short data sheet is an extract from a full data sheet with the same product type number(s) and title. A short data sheet is intended for quick reference only and should not be relied upon to contain detailed and full information. For detailed and full information see the relevant full data sheet, which is available on request via the local NXP Semiconductors sales office. In case of any inconsistency or conflict with the short data sheet, the full data sheet shall prevail.

Product specification — The information and data provided in a Product data sheet shall define the specification of the product as agreed between NXP Semiconductors and its customer, unless NXP Semiconductors and customer have explicitly agreed otherwise in writing. In no event however, shall an agreement be valid in which the NXP Semiconductors product is deemed to offer functions and qualities beyond those described in the Product data sheet.

18.3 Disclaimers

Limited warranty and liability — Information in this document is believed to be accurate and reliable. However, NXP Semiconductors does not give any representations or warranties, expressed or implied, as to the accuracy or completeness of such information and shall have no liability for the consequences of use of such information.

In no event shall NXP Semiconductors be liable for any indirect, incidental, punitive, special or consequential damages (including - without limitation - lost profits, lost savings, business interruption, costs related to the removal or replacement of any products or rework charges) whether or not such damages are based on tort (including negligence), warranty, breach of contract or any other legal theory.

Notwithstanding any damages that customer might incur for any reason whatsoever, NXP Semiconductors' aggregate and cumulative liability towards customer for the products described herein shall be limited in accordance with the *Terms and conditions of commercial sale* of NXP Semiconductors.

Right to make changes — NXP Semiconductors reserves the right to make changes to information published in this document, including without limitation specifications and product descriptions, at any time and without notice. This document supersedes and replaces all information supplied prior to the publication hereof.

Suitability for use — NXP Semiconductors products are not designed, authorized or warranted to be suitable for use in life support, life-critical or safety-critical systems or equipment, nor in applications where failure or

malfunction of an NXP Semiconductors product can reasonably be expected to result in personal injury, death or severe property or environmental damage. NXP Semiconductors accepts no liability for inclusion and/or use of NXP Semiconductors products in such equipment or applications and therefore such inclusion and/or use is at the customer's own risk.

Applications — Applications that are described herein for any of these products are for illustrative purposes only. NXP Semiconductors makes no representation or warranty that such applications will be suitable for the specified use without further testing or modification.

Customers are responsible for the design and operation of their applications and products using NXP Semiconductors products, and NXP Semiconductors accepts no liability for any assistance with applications or customer product design. It is customer's sole responsibility to determine whether the NXP Semiconductors product is suitable and fit for the customer's applications and products planned, as well as for the planned application and use of customer's third party customer(s). Customers should provide appropriate design and operating safeguards to minimize the risks associated with their applications and products.

NXP Semiconductors does not accept any liability related to any default, damage, costs or problem which is based on any weakness or default in the customer's applications or products, or the application or use by customer's third party customer(s). Customer is responsible for doing all necessary testing for the customer's applications and products using NXP Semiconductors products in order to avoid a default of the applications and the products or of the application or use by customer's third party customer(s). NXP does not accept any liability in this respect.

Limiting values — Stress above one or more limiting values (as defined in the Absolute Maximum Ratings System of IEC 60134) will cause permanent damage to the device. Limiting values are stress ratings only and (proper) operation of the device at these or any other conditions above those given in the Recommended operating conditions section (if present) or the Characteristics sections of this document is not warranted. Constant or repeated exposure to limiting values will permanently and irreversibly affect the quality and reliability of the device.

Terms and conditions of commercial sale — NXP Semiconductors products are sold subject to the general terms and conditions of commercial sale, as published at <http://www.nxp.com/profile/terms>, unless otherwise agreed in a valid written individual agreement. In case an individual agreement is concluded only the terms and conditions of the respective agreement shall apply. NXP Semiconductors hereby expressly objects to applying the customer's general terms and conditions with regard to the purchase of NXP Semiconductors products by customer.

No offer to sell or license — Nothing in this document may be interpreted or construed as an offer to sell products that is open for acceptance or the grant, conveyance or implication of any license under any copyrights, patents or other industrial or intellectual property rights.

Export control — This document as well as the item(s) described herein may be subject to export control regulations. Export might require a prior authorization from national authorities.