



Chipsmall Limited consists of a professional team with an average of over 10 year of expertise in the distribution of electronic components. Based in Hongkong, we have already established firm and mutual-benefit business relationships with customers from,Europe,America and south Asia,supplying obsolete and hard-to-find components to meet their specific needs.

With the principle of “Quality Parts,Customers Priority,Honest Operation,and Considerate Service”,our business mainly focus on the distribution of electronic components. Line cards we deal with include Microchip,ALPS,ROHM,Xilinx,Pulse,ON,Everlight and Freescale. Main products comprise IC,Modules,Potentiometer,IC Socket,Relay,Connector.Our parts cover such applications as commercial,industrial, and automotives areas.

We are looking forward to setting up business relationship with you and hope to provide you with the best service and solution. Let us make a better world for our industry!



## Contact us

Tel: +86-755-8981 8866 Fax: +86-755-8427 6832

Email & Skype: info@chipsmall.com Web: www.chipsmall.com

Address: A1208, Overseas Decoration Building, #122 Zhenhua RD., Futian, Shenzhen, China



## SPECIFICATION

Part No. : **PCB.MMCXFSTJ.SMT.HT**

Product Name : MMCX(F) Surface Mount Jack

Feature : MMCX(F) Jack  
Surface Mount PCB Jack  
Frequency Range: DC up to 6GHz  
Finish: Gold  
Leg Length: 0.76mm  
Total Length: 5mm  
RoHS Compliant



# 1. Introduction

The PCB.MMCXFSTJ.SMT.HT connector was designed to be surface mounted on a PCB. The maximum thickness of PCB that the connector can be used with is 0.4mm. The connector pin is directly soldered onto pads on the PCB. The connector is a standard MMCX (F) Jack. Taoglas connectors are all RoHS compliant.



# 2. Specification

ELECTRICAL	
Impedance	50Ω
Frequency Range	DC~6 GHz
Working Voltage	Max. ≤170 Vrms
Dielectric withstanding Voltage	500 Vrms
Insulation Resistance	≥1000M MΩ
MECHANICAL	
Connector Dimension	5mm*Ø3.5mm
Max. Thickness PCB acceptable	0.4 mm
Connector Pin Diameter	0.75 mm
Connector Type	MMCX(F) Jack for surface Mount
ENVIRONMENTAL	
RoHS compliant	
Operating Temperature	-40°C to +85°C

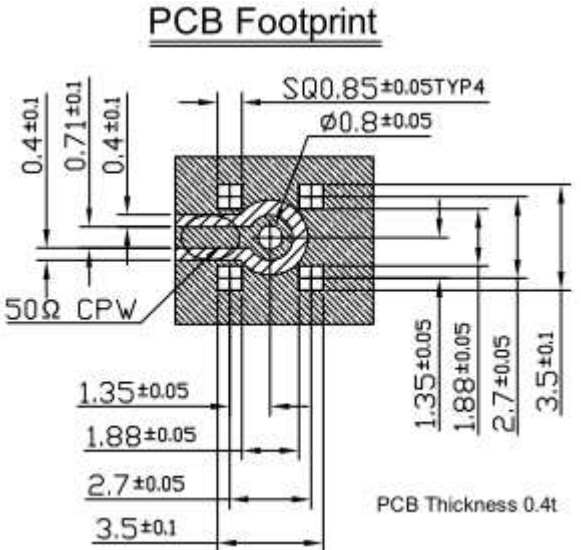
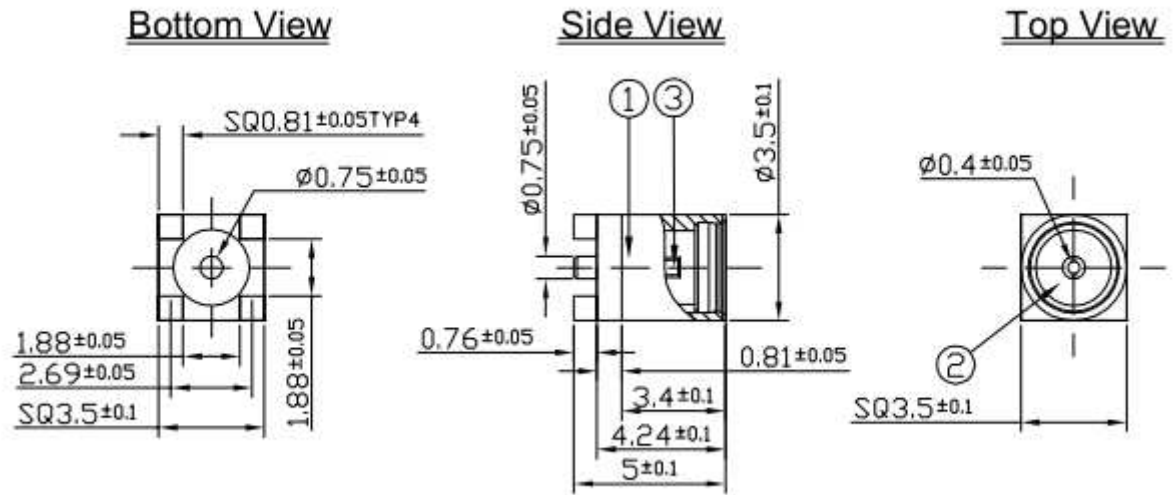

### 3.Connector Drawing



- Note:
- 1. Copper with Solder Mask 
  - 2. Solder Area 
  - 3. Clearance Area 

	Name	Material	Finish	QTY
1	Body	Brass	Gold	1
2	Insulator	Teflon	White	1
3	Female Contact	Phosphor Bronze	Gold	1

Taoglas makes no warranties based on the accuracy or completeness of the contents of this document and reserves the right to make changes to specifications and product descriptions at any time without notice. Taoglas reserves all rights to this document and the information contained herein. Reproduction, use or disclosure to third parties without express permission is strictly prohibited. Copyright © 2012, Taoglas Ltd.