



Chipsmall Limited consists of a professional team with an average of over 10 year of expertise in the distribution of electronic components. Based in Hongkong, we have already established firm and mutual-benefit business relationships with customers from,Europe,America and south Asia,supplying obsolete and hard-to-find components to meet their specific needs.

With the principle of “Quality Parts,Customers Priority,Honest Operation,and Considerate Service”,our business mainly focus on the distribution of electronic components. Line cards we deal with include Microchip,ALPS,ROHM,Xilinx,Pulse,ON,Everlight and Freescale. Main products comprise IC,Modules,Potentiometer,IC Socket,Relay,Connector.Our parts cover such applications as commercial,industrial, and automotives areas.

We are looking forward to setting up business relationship with you and hope to provide you with the best service and solution. Let us make a better world for our industry!



Contact us

Tel: +86-755-8981 8866 Fax: +86-755-8427 6832

Email & Skype: info@chipsmall.com Web: www.chipsmall.com

Address: A1208, Overseas Decoration Building, #122 Zhenhua RD., Futian, Shenzhen, China



PCF2003

32 kHz watch circuit with programmable adaptive motor pulse and pulse period

Rev. 1 — 20 October 2015

Product data sheet

1. General description

The PCF2003 is a CMOS integrated circuit for battery operated wrist watches with a 32 kHz quartz crystal as timing element and a bipolar 1 Hz stepping motor. The quartz crystal oscillator and the frequency divider are optimized for minimum power consumption. A timing accuracy of 1 ppm is achieved with a programmable, digital frequency adjustment.

To obtain the minimum overall power consumption for the watch, an automatic motor pulse adaptation function is provided. The circuit supplies only the minimum drive current, which is necessary to ensure a correct motor step. Changing the drive current of the motor is achieved by chopping the motor pulse with a variable duty cycle. The pulse period and the range of the variable duty cycle can be programmed to suit different types of motors. The automatic pulse adaptation scheme is based on a safe dynamic detection of successful motor steps.

A pad RESET is provided (used for stopping the motor) for accurate time setting and for accelerated testing of the watch.

2. Features and benefits

- Amplitude-regulated 32 kHz quartz crystal oscillator, with excellent frequency stability and high immunity to leakage currents
- Electrically programmable time calibration with 1 ppm resolution stored in One Time Programmable (OTP) memory
- The quartz crystal is the only external component connected
- Very low supply current, typical 90 nA
- One second output pulses for bipolar stepping motor
- Five different programmable output periods (1 s to 30 s)
- Minimum power consumption for the entire watch, due to self adaptation of the motor drive according to the required torque
- Reliable step detection circuit
- Motor pulse width, pulse modulation, and pulse adaptation range programmable in a wide range, stored in OTP memory
- Stop function for accurate time setting and power saving during shelf life
- Test mode for accelerated testing of the mechanical parts of the watch and the IC
- Test bits for type recognition



3. Applications

- Driver circuits for bipolar stepping motors
- High immunity motor drive circuits

4. Ordering information

Table 1. Ordering information

Type number	Topside marking	Package		
		Name	Description	Version
PCF2003DUS/DA	L[1]	WLCSP8	wafer level chip-size package; 8 bumps; 1.16 mm × 0.86 mm	PCF2003DUS

[1] The only marking is the “L” symbol for pin 1 location; see [Figure 14](#).

4.1 Ordering options

Table 2. Ordering options

Type number	Orderable part number	Package	Packing method	Minimum order quantity	Temperature
PCF2003DUS/DA	PCF2003DUS/DAAZ	WLCSP8	chips with solder bumps in tape and reel, 7 inch, dry pack	4000	T _{amb} = -10 °C to +60 °C

5. Block diagram

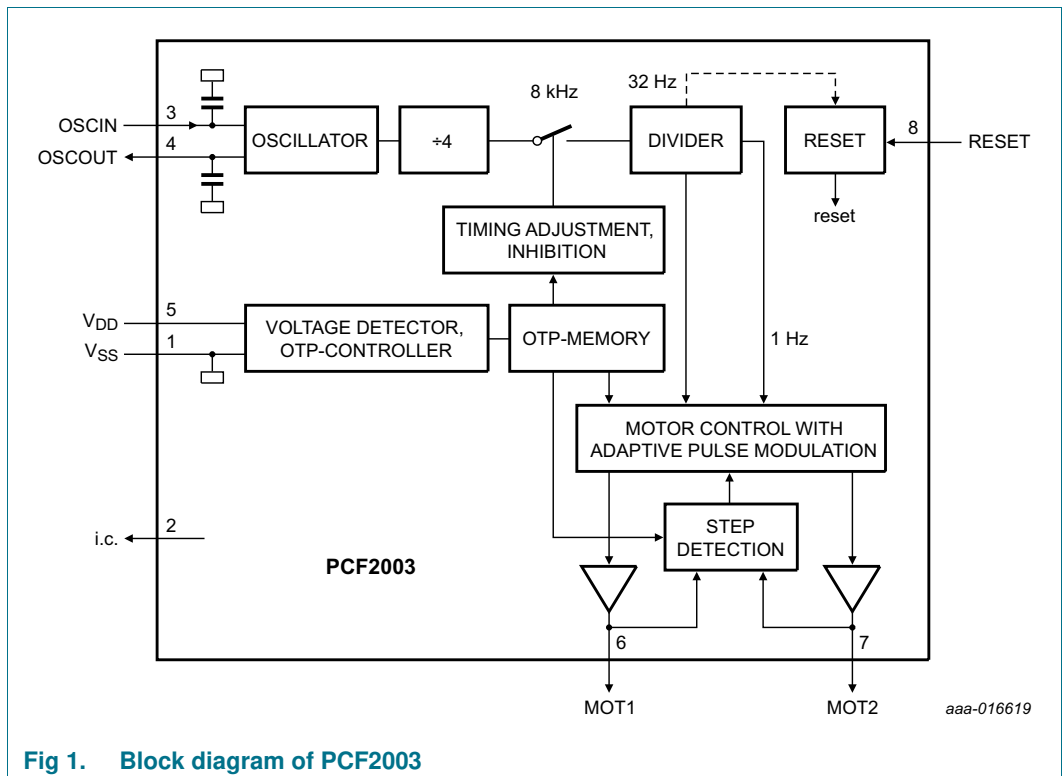
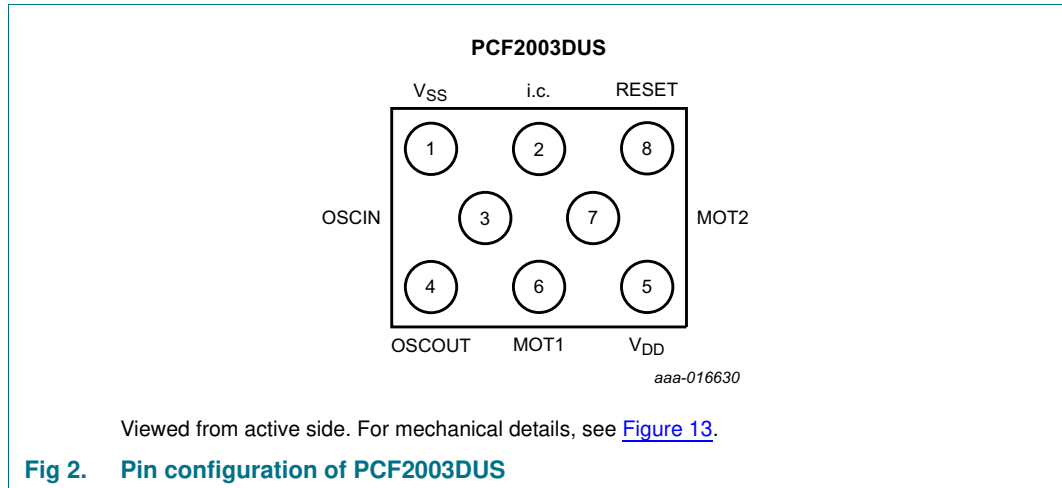

Fig 1. Block diagram of PCF2003

6. Pinning information

6.1 Pinning



6.2 Pin description

Table 3. Pin description

Input or input/output pins must always be at a defined level (V_{SS} or V_{DD}) unless otherwise specified.

Symbol	Pin	Description
V _{SS} ^[1]	1	ground
i.c. ^[2]	2	internally connected
OSCIN	3	oscillator input
OSCOUT	4	oscillator output
V _{DD}	5	supply voltage
MOT1	6	motor 1 output
MOT2	7	motor 2 output
RESET	8	reset input

[1] The substrate (rear side of the chip) is connected to V_{SS}. Therefore the die pad must be either floating or connected to V_{SS}.

[2] Pad i.c. is used for factory tests; in normal operation it should be left open-circuit, and it has an internal pull-down resistance to V_{SS}.

7. Functional description

7.1 Motor pulse

The motor output supplies pulses of different driving stages, depending on the torque required to turn on the motor. The number of different stages can be selected between three and six. With the exception of the highest driving stage, each motor pulse (t_p in [Figure 3](#) and [Figure 6](#)) is followed by a detection phase during which the motor movement is monitored, in order to check whether the motor has turned correctly or not.

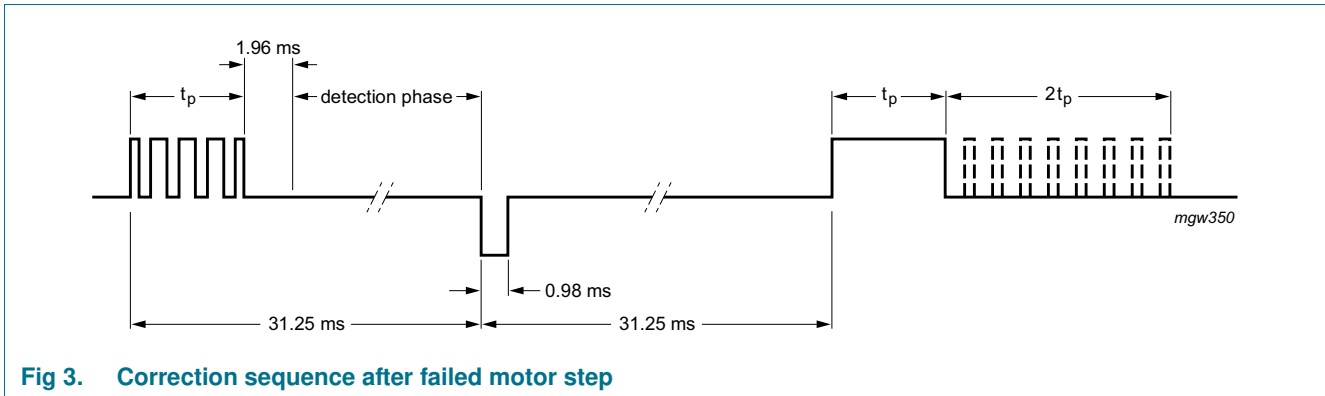

Fig 3. Correction sequence after failed motor step

If a missing step is detected, a correction sequence is generated (see [Figure 3](#)) and the driving stage is switched to the next level. The correction sequence consists of two pulses: first a short pulse in the opposite direction (0.98 ms, modulated with the maximum duty cycle) to give the motor a defined position, followed by a motor pulse of the strongest driving level. Every 4 minutes, the driving level is lowered again by one stage.

The motor pulse has a constant pulse width. The driving level is regulated by chopping the driving pulse with a variable duty cycle. The driving level starts from the programmed minimum value and increases by 6.25 % after each failed motor step. The strongest driving stage, which is not followed by a detection phase, is programmed separately.

Therefore, it is possible to program a larger energy gap between the pulses with step detection and the strongest, not monitored, pulse. This might be necessary to ensure a reliable and stable operation under adverse conditions (magnetic fields and vibrations). If the watch works in the highest driving stage, the driving level jumps after the 4-minute period directly to the lowest stage, and not just one stage lower.

To optimize the performance for different motors, the following parameters can be programmed:

- Pulse width: 0.98 ms to 7.8 ms in steps of 0.98 ms
- Duty cycle of lowest driving level: 37.5 % to 56.25 % in steps of 6.25 %
- Number of driving levels (including the highest driving level): 3 to 6
- Duty cycle of the highest driving level: 75 % or 100 %
- Enlargement pulse for the highest driving level: on or off

The enlargement pulse has a duty cycle of 25 % and a pulse width which is twice the programmed motor pulse width. The repetition period for the chopping pattern is 0.98 ms. [Figure 4](#) shows an example of a 3.9 ms pulse.

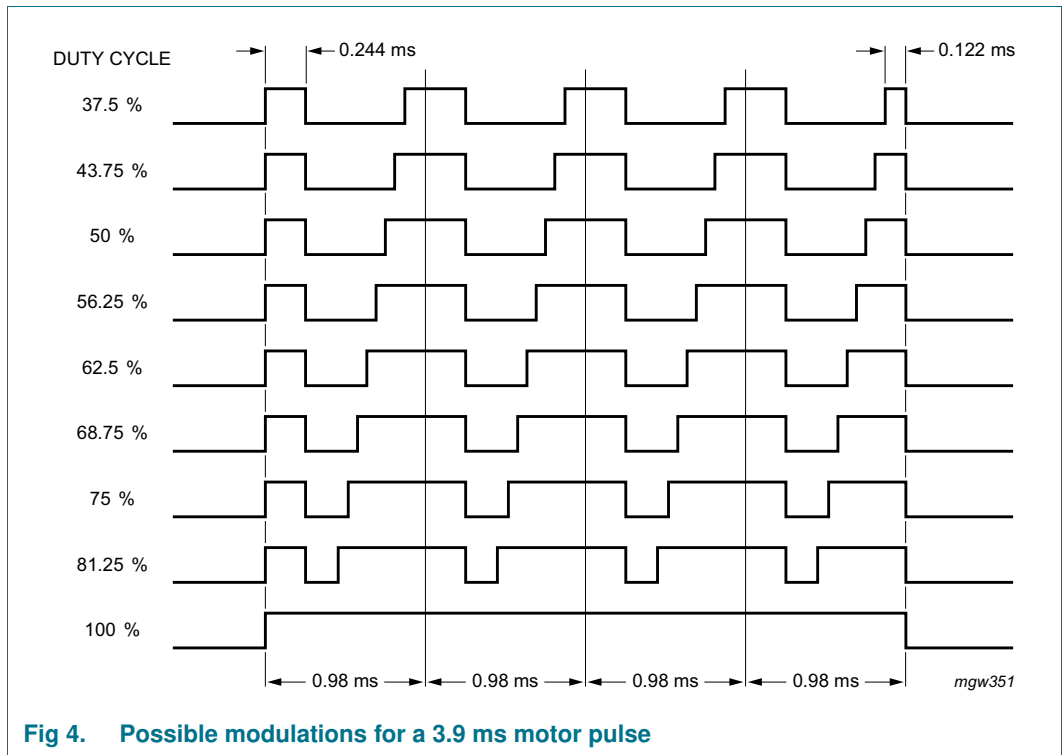

Fig 4. Possible modulations for a 3.9 ms motor pulse

7.2 Step detection

Figure 5 shows a simplified diagram of the motor driving and step detection circuit, and Figure 6 shows the step detection sequence and corresponding sampling current. Between the motor driving pulses, the switches P1 and P2 are closed, which means the motor is short-circuited. For a pulse in one direction, P1 and N2 are open, and P2 and N1 are closed with the appropriate duty cycle; for a pulse in the opposite direction, P2 and N1 are open, and P1 and N2 closed.

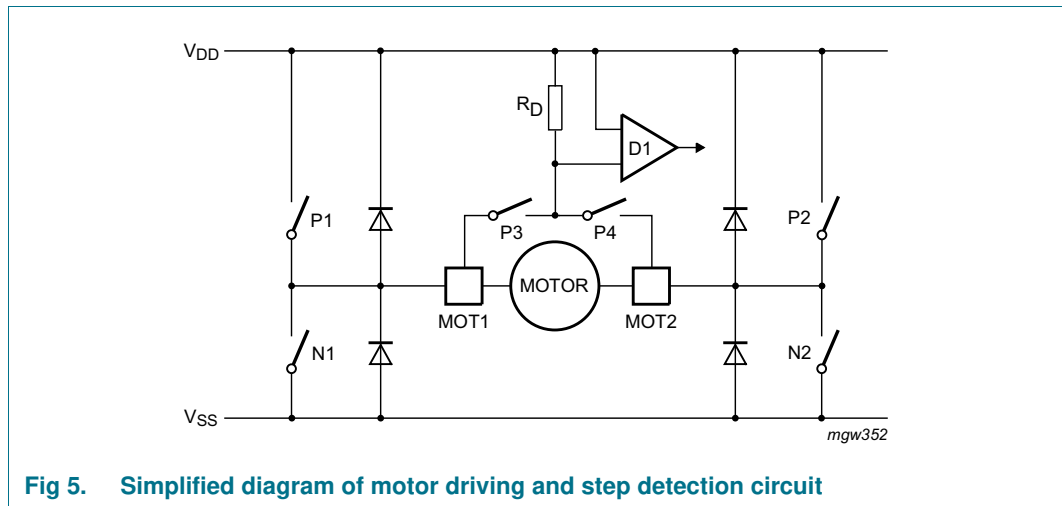

Fig 5. Simplified diagram of motor driving and step detection circuit

The step detection phase is initiated after the motor driving pulse. In phase 1 P1 and P2 are first closed for 0.98 ms and then in phase 2 all four drive switches (P1, N1, P2 and N2) are opened for 0.98 ms. As a result, the energy stored in the motor inductance is reduced as fast as possible.

The induced current caused by the residual motor movement is then sampled in phase 3 (closing P3 and P2) and in phase 4 (closing P1 and P4). For step detection in the opposite direction P1 and P4 are closed during phase 3 and P2 and P3 during phase 4 (see Figure 6).

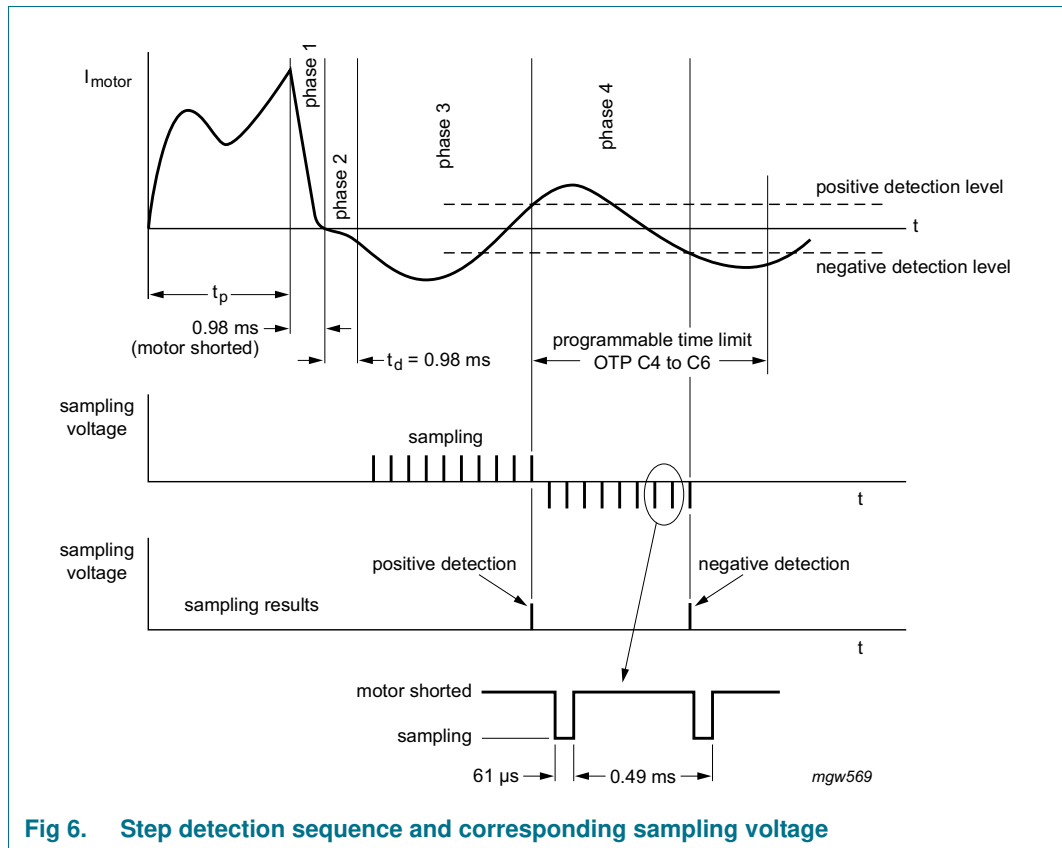

Fig 6. Step detection sequence and corresponding sampling voltage

The condition for a successful motor step is a positive step detection pulse (current in the same direction as in the driving phase) followed by a negative detection pulse within a given time limit. This time limit can be programmed between 3.9 ms and 10.7 ms (in steps of 0.98 ms) in order to ensure a safe and correct step detection under all conditions (for instance magnetic fields). The step detection phase stops after the last 31.25 ms, after the start of the motor driving pulse.

7.3 Time calibration

The quartz crystal oscillator has an integrated capacitance of 5.2 pF, which is lower than the specified capacitance (C_L) of 8.2 pF for the quartz crystal (see Table 11). Therefore, the oscillator frequency is typically 60 ppm higher than 32.768 kHz. This positive frequency offset is compensated by removing the appropriate number of 8 192 Hz pulses in the divider chain (maximum 127 pulses), every 1 or 2 minutes. The time correction is given in Table 4.

Table 4. Time calibration

Calibration period	Correction per step (n = 1)		Correction per step (n = 127)	
	ppm	Seconds per day	ppm	Seconds per day
1 minute	2.03	0.176	258	22.3
2 minutes	1.017	0.088	129	11.15

After measuring the effective oscillator frequency, the number of correction pulses must be calculated and stored together with the calibration period in the OTP memory (see Section 7.7).

32 kHz watch circuit with programmable adaptive motor pulse

The oscillator frequency can be measured at pad RESET, where a square wave signal with the frequency of $\frac{1}{1024} \times f_{osc}$ is provided. This frequency shows a jitter every minute or every two minutes, which originates from the time calibration, depending on the programmed calibration period.

Details on how to measure the oscillator frequency and the programmed inhibition time are given in [Section 7.10](#).

7.4 Reset

At pad RESET an output signal with a frequency of $\frac{1}{1024} \times f_{osc} = 32 \text{ Hz}$ is provided.

Connecting pad RESET to V_{DD} stops the motor drive and opens all four (P1, N1, P2 and N2) driver switches (see [Figure 5](#)). Connecting pad RESET to V_{SS} activates the test mode. In this mode the motor output frequency is 32 Hz, which can be used to test the mechanical function of the watch.

After releasing the pad RESET, the motor starts exactly one second later with the smallest duty cycle and with the opposite polarity to the last pulse before stopping. The debounce time for the RESET function is between 31 ms and 62 ms.

7.5 Programming possibilities

The programming data is stored in OTP cells (EPROM cells). At delivery, all memory cells are in state 0. The cells can be programmed to the state 1, but then there is no more set back to state 0. The programming data is organized in an array of four 8-bit words (see [Table 5](#)): word A contains the time calibration, words B and C contain the setting for the motor pulses and word D contains the type recognition.

Table 5. Words and bits

Word	Bit							
	1	2	3	4	5	6	7	8
A	number of 8192 Hz pulses to be removed							calibration period
B	lowest stage: duty cycle		number of driving stages		highest stage: duty cycle	pulse stretching	output period	
C	pulse width			maximum time delay between positive and negative detection pulses			output period	factory test bit
D	type				factory test bits			

Table 6. Description of word A bits

Bit	Value	Description
Inhibition time		
1 to 7	-	adjust the number of the 8192 Hz pulses to be removed; bit 1 is the MSB and bit 7 is the LSB
Calibration period		
8	0	1 minute
	1	2 minutes

Table 7. Description of word B bits

Bit	Value	Description
Duty cycle lowest driving stage		
1 to 2	00	37.5 %
	01	43.75 %
	10	50 %
	11	56.25 %
Number of driving stages		
3 to 4	00	3
	01	4
	10	5
	11	6 ^[1]
Duty cycle highest driving stage		
5	0	75 % ^[2]
	1	100 %
Pulse stretching		
6	0	no pulse stretching
	1	pulse of $2 \times t_p$ and duty cycle of 25 % are added
Output period		
7 to 8	00	1 s
	01	5 s
	10	10 s
	11	20 s

[1] Including the highest driving stage, which one has no motor step detection.

[2] If the maximum duty cycle of 75 % is selected, not all programming combinations are possible since the second highest level must be smaller than the highest driving level.

Table 8. Description of word C bits

Bit	Value	Description
Pulse width t_p		
1 to 3	000	0.98 ms
	001	1.95 ms
	010	2.90 ms
	011	3.90 ms
	100	4.90 ms
	101	5.90 ms
	110	6.80 ms
	111	7.80 ms
Time delay $t_{d(max)}$ [1]		
4 to 6	000	3.91 ms
	001	4.88 ms
	010	5.86 ms
	011	6.84 ms
	100	7.81 ms
	101	8.79 ms
	110	9.77 ms
	111	10.74 ms
Output period		
7	0	bit 7 and 8 of word B active
	1	30 s, bit 7 and 8 of word B inactive
Factory test bit		
8	-	-

[1] Between positive and negative detection pulses.

Byte D is read to determine which type of the PCA200x family is used in a particular application.

Table 9. Description of word D bits

Bit	Value	Description
Type recognition		
1 to 4	0000	PCA2002
	1000	PCA2000
	0100	PCA2001
	1100	PCA2003
Factory test bits		
5 to 8	-	-

7.6 Programming procedure

For a watch it is essential that the timing calibration can be made after the watch is fully assembled. In this situation, the supply pads are often the only terminals which are still accessible.

Writing to the OTP cells and performing the related functional checks is achieved in the PCF2003 by modulating the supply voltage. The necessary control circuit consists basically of a voltage level detector, an instruction counter which determines the function to be performed, and an 8-bit shift register which allows writing to the OTP cells of an 8-bit word in one step and acts as a data pointer for checking the OTP content.

There are six different instruction states (state 3 and state 5 are handled as state 4):

- State 1: measurement of the quartz crystal oscillator frequency (divided by 1024)
- State 2: measurement of the inhibition time
- State 3: write/check word A
- State 4: write/check word B
- State 5: write/check word C
- State 6: check word D (type recognition)

Each instruction state is switched on with a pulse to $V_{P(prog)(start)}$. After this large pulse, an initial waiting time of t_0 is required. The programming instructions are then entered by modulating the supply voltage with small pulses (amplitude $V_{P(mod)}$ and pulse width t_{mod}). The first small pulse defines the start time, the following pulses perform three different functions, depending on the time delay (t_d) from the preceding pulse (see [Figure 7](#), [Figure 8](#), [Figure 11](#) and [Figure 12](#)):

- $t_d = t_1$ (0.7 ms); increments the instruction counter
- $t_d = t_2$ (1.7 ms); clocks the shift register with data = logic 0
- $t_d = t_3$ (2.7 ms); clocks the shift register with data = logic 1

The programming procedure requires a stable oscillator. This means that a waiting time, determined by the start-up time of the oscillator is necessary after power-on of the circuit.

After the $V_{P(prog)(start)}$ pulse, the instruction counter is in state 1 and the data shift register is cleared.

The instruction state ends with a second pulse to $V_{P(prog)(stop)}$ or with a pulse to V_{store} .

In any case, the instruction states are terminated automatically 2 seconds after the last supply modulation pulse.

7.7 Programming the memory cells

Applying the two-stage programming pulse (see [Figure 7](#)) transfers the stored data in the shift register to the OTP cells.

Perform the following to program a memory word:

1. Starting with a $V_{P(prog)(start)}$ pulse wait for the time period t_0 then set the instruction counter to the word to be written ($t_d = t_1$).

2. Enter the data to be stored in the shift register ($t_d = t_2$ or t_3). LSB first (bit 8) and the MSB last (bit 1).
3. Applying the two-stage programming pulse $V_{prestore}$ followed by V_{store} stores the word. The delay between the last data bit and the prestore pulse $V_{prestore}$ is $t_d = t_4$. Store the word by raising the supply voltage to V_{store} ; the delay between the last data bit and the store pulse is t_d .

The example shown in [Figure 7](#) performs the following functions:

- Start
- Setting instruction counter to state 4 (word B)
- Entering data word 110101 into the shift register (sequence: LSB first and MSB last)
- Writing to the OTP cells for word B

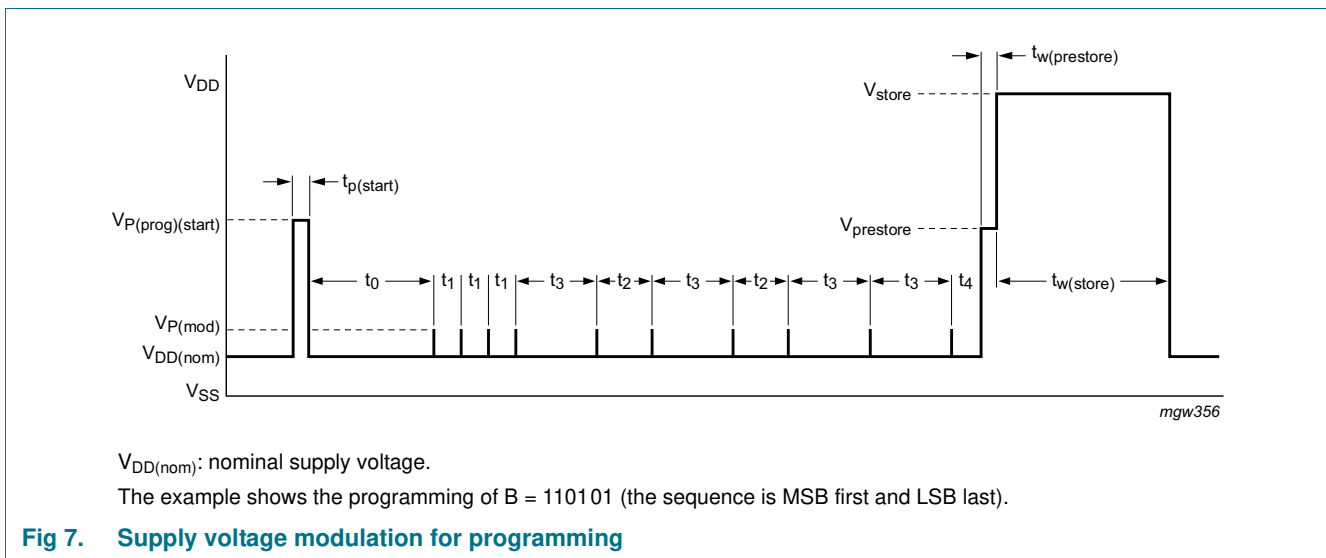

7.8 Checking memory content

The stored data of the OTP array can be checked bit wise by measuring the supply current. The array word is selected by the instruction state and the bit is addressed by the shift register.

To read a word, the word is first selected ($t_d = t_1$), and a logic 1 is written into the first cell of the shift register ($t_d = t_3$). This logic 1 is then shifted through the entire shift register ($t_d = t_2$), so that it points with each clock pulse to the next bit.

If the addressed OTP cell contains a logic 1, a $30\text{ k}\Omega$ resistor is connected between V_{DD} and V_{SS} , which increases the supply current accordingly.

[Figure 8](#) shows the supply voltage modulation for reading word B, with the corresponding supply current variation for word $B = 110101$ (sequence: first MSB and last LSB).

32 kHz watch circuit with programmable adaptive motor pulse

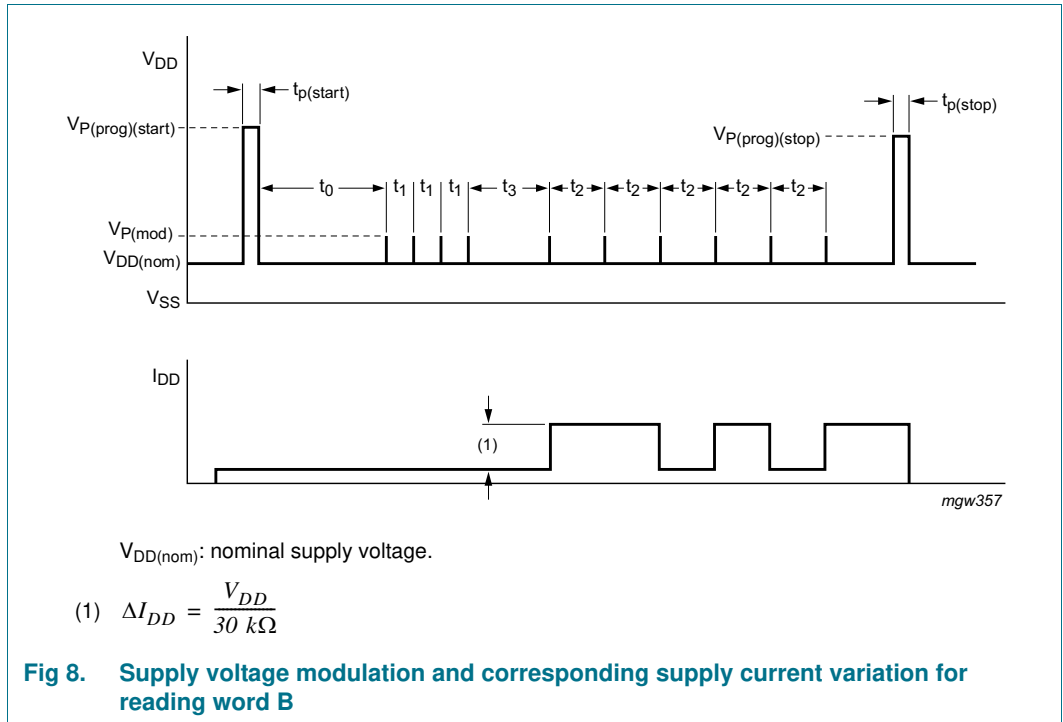

Fig 8. Supply voltage modulation and corresponding supply current variation for reading word B

7.9 Frequency tuning of assembled watch

Figure 9 shows the test set-up for frequency tuning the assembled watch.

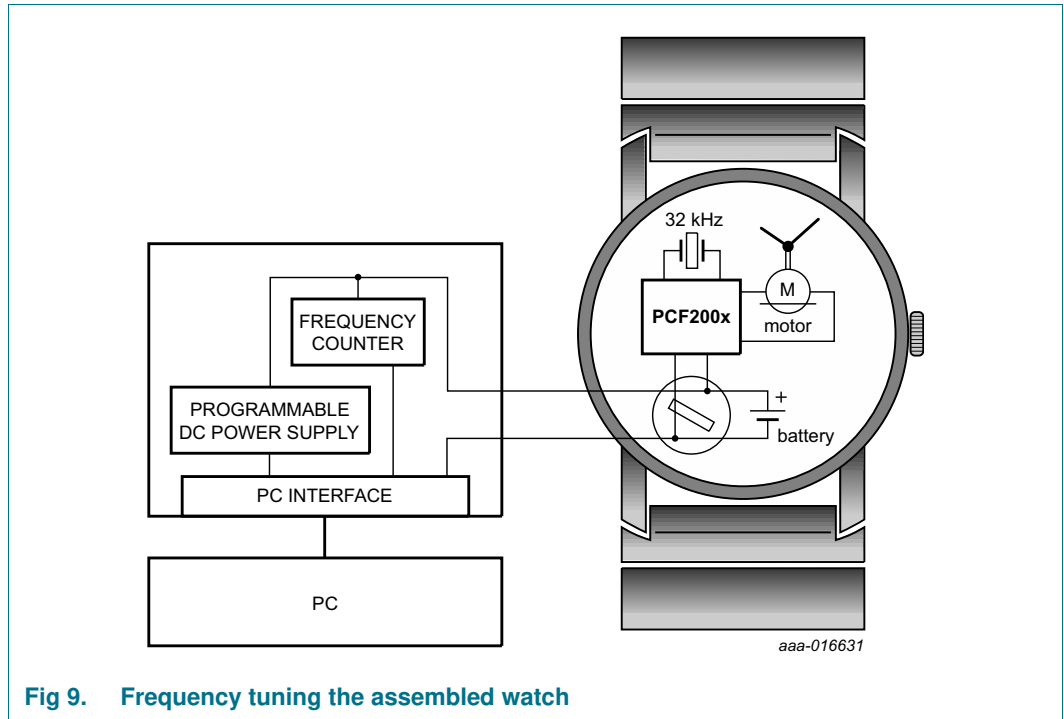

Fig 9. Frequency tuning the assembled watch

7.10 Measurement of oscillator frequency and inhibition time

The output of the two measuring states can either be monitored directly at pad RESET or as a modulation of the supply voltage (a modulating resistor of 30 kΩ is connected between V_{DD} and V_{SS} when the signal at pad RESET is at HIGH-level).

The supply voltage modulation must be followed as shown in Figure 10 in order to guarantee the correct start-up of the circuit during production and testing.

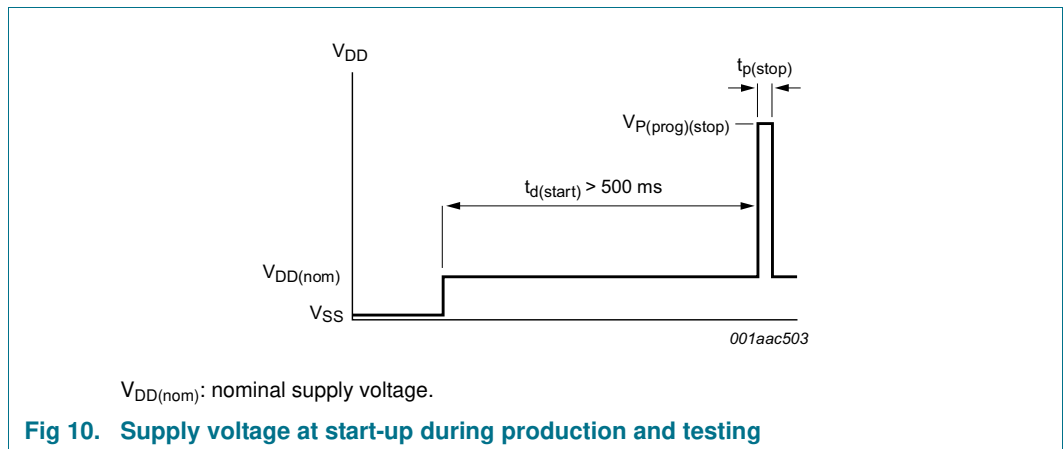

Fig 10. Supply voltage at start-up during production and testing

Measuring states:

32 kHz watch circuit with programmable adaptive motor pulse

- State 1: quartz crystal oscillator frequency divided by 1024; state 1 starts with a pulse to V_P and ends with a second pulse to V_P
- State 2: inhibition time has a value of $n \times 0.122$ ms. A signal with periodicity of 31.25 ms + $n \times 0.122$ ms appears at pad RESET and as current modulation at pad V_{DD} (see [Figure 11](#) and [Figure 12](#))

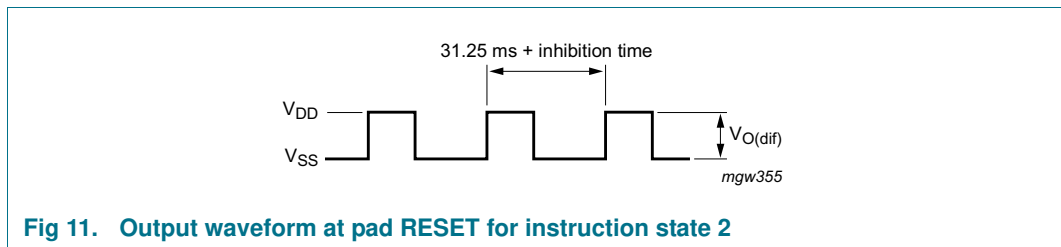

Fig 11. Output waveform at pad RESET for instruction state 2

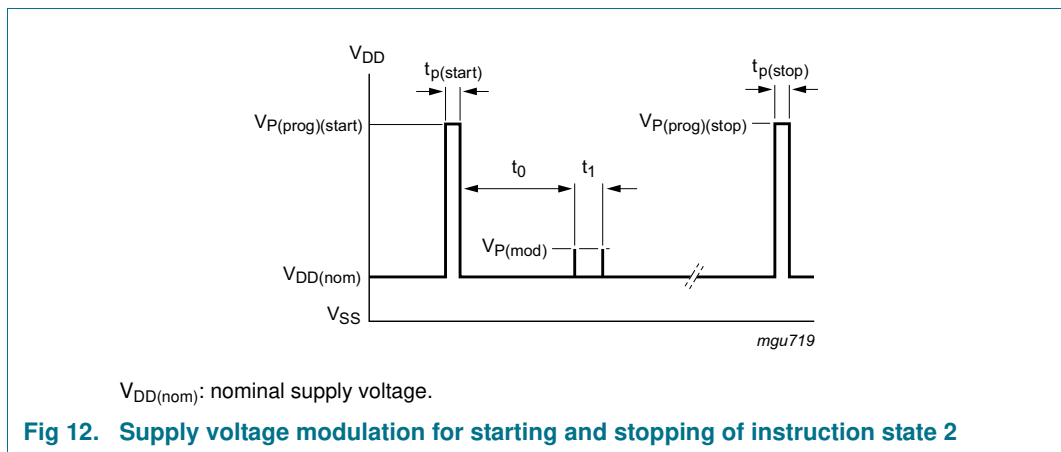

Fig 12. Supply voltage modulation for starting and stopping of instruction state 2

7.11 Customer testing

Connecting pad RESET to V_{SS} activates the test mode. In this test mode, the motor output frequency is 8 Hz; the duty cycle reduction and battery check occurs every second, instead of every 4 minutes.

8. Safety notes

CAUTION



This device is sensitive to ElectroStatic Discharge (ESD). Observe precautions for handling electrostatic sensitive devices. Such precautions are described in the *ANSI/ESD S20.20*, *IEC/ST 61340-5*, *JESD625-A* or equivalent standards.

CAUTION



Semiconductors are light sensitive. Exposure to light sources can cause the IC to malfunction. The IC must be protected against light. The protection must be applied to all sides of the IC.

9. Limiting values

Table 10. Limiting values

In accordance with the Absolute Maximum Rating System (IEC 60134).

Symbol	Parameter	Conditions	Min	Max	Unit
V _{DD}	supply voltage	V _{SS} = 0 V [1][2]	-1.8	+7.0	V
V _I	input voltage	on all supply pins	-0.5	+7.5	V
t _{sc}	short circuit duration time	output	-	indefinite	s
T _{amb}	ambient temperature		-10	+60	°C
V _{ESD}	electrostatic discharge voltage	HBM [3]	-	±2000	V
		MM [4]	-	±200	V
I _{lu}	latch-up current		[5]	100	mA
T _{stg}	storage temperature		[6]	+100	°C

- [1] When writing to the OTP cells, the supply voltage (V_{DD}) can be raised to a maximum of 12 V for a time period of 1 s.
- [2] Connecting the battery with reversed polarity does not destroy the circuit, but in this condition a large current flows, which rapidly discharges the battery.
- [3] Pass level; Human Body Model (HBM), according to [Ref. 6 "JESD22-A114"](#).
- [4] Pass level; Machine Model (MM), according to [Ref. 7 "JESD22-A115"](#).
- [5] Pass level; latch-up testing according to [Ref. 8 "JESD78"](#) at maximum ambient temperature (T_{amb(max)}).
- [6] According to the store and transport requirements (see [Ref. 10 "UM10569"](#)) the devices have to be stored at a temperature of +8 °C to +45 °C and a humidity of 25 % to 75 %.

10. Characteristics

Table 11. Characteristics

$V_{DD} = 1.55\text{ V}$; $V_{SS} = 0\text{ V}$; $f_{osc} = 32.768\text{ kHz}$; $T_{amb} = 25\text{ °C}$; quartz crystal: $R_S = 40\text{ k}\Omega$, $C_1 = 2\text{ fF to }3\text{ fF}$, $C_L = 8.2\text{ pF}$; unless otherwise specified.

Symbol	Parameter	Conditions	Min	Typ	Max	Unit
Supply						
V_{DD}	supply voltage	normal operating mode; $T_{amb} = -10\text{ °C to }+60\text{ °C}$	1.1	1.55	3.60	V
ΔV_{DD}	supply voltage variation	$\Delta V/\Delta t = 1\text{ V}/\mu\text{s}$	-	-	0.25	V
I_{DD}	supply current	between motor pulses	-	90	120	nA
		between motor pulses at $V_{DD} = 3.5\text{ V}$	-	120	180	nA
		$T_{amb} = -10\text{ °C to }+60\text{ °C}$	-	-	200	nA
		stop mode; pad RESET connected to V_{DD}	-	100	135	nA
Motor output						
V_{sat}	saturation voltage	$R_{motor} = 2\text{ k}\Omega$; $T_{amb} = -10\text{ °C to }+60\text{ °C}$ [1]	-	150	200	mV
$Z_{o(sc)}$	output impedance (short circuit)	between motor pulses; $I_{motor} < 1\text{ mA}$	-	200	300	Ω
Oscillator						
V_{start}	start voltage		1.1	-	-	V
g_m	transconductance	$V_{i(osc)} \leq 50\text{ mV (p-p)}$	5	10	-	μS
$t_{startup}$	start-up time		-	0.3	0.9	s
$\Delta f/f$	frequency stability	$\Delta V_{DD} = 100\text{ mV}$	-	0.05	0.20	ppm
$C_{L(itg)}$	integrated load capacitance		4.3	5.2	6.3	pF
R_{par}	parasitic resistance	allowed resistance between adjacent pads	20	-	-	$\text{M}\Omega$
Pad RESET						
f_o	output frequency		-	32	-	Hz
$V_{O(dif)}$	differential output voltage	$R_L = 1\text{ M}\Omega$; $C_L = 10\text{ pF}$ [2]	1.4	-	-	V
t_r	rise time	$R_L = 1\text{ M}\Omega$; $C_L = 10\text{ pF}$ [2]	-	1	-	μs
t_f	fall time	$R_L = 1\text{ M}\Omega$; $C_L = 10\text{ pF}$ [2]	-	1	-	μs
$I_{i(AV)}$	average input current	pad RESET connected to V_{DD} or V_{SS}	-	10	20	nA

[1] $P1 + \dots + P4 + N1 + N2$ (see [Section 7.2](#)).

[2] R_L and C_L are a load resistor and load capacitor, externally connected to pad RESET.

11. OTP programming characteristics

Table 12. Specifications for OTP programming

See [Figure 7](#), [Figure 8](#) and [Figure 12](#).

Symbol	Parameter ^[1]	Conditions	Min	Typ	Max	Unit
V_{DD}	supply voltage	during programming procedure	1.5	-	3.0	V
$V_{P(prog)(start)}$	programming supply voltage (start)		6.6	-	6.8	V
$V_{P(prog)(stop)}$	programming supply voltage (stop)		6.2	-	6.4	V
$V_{P(mod)}$	supply voltage modulation	for entering instructions, referred to V_{DD}	320	350	380	mV
$V_{prestore}$	prestore voltage	for prestore pulse	6.2	-	6.4	V
V_{store}	store voltage	for writing to the OTP cells	9.9	10.0	10.1	V
I_{store}	store current	for writing to the OTP cells	-	-	10	mA
$t_{p(start)}$	start pulse width		8	10	12	ms
$t_{p(stop)}$	pulse width of stop pulse		0.05	-	0.5	ms
t_{mod}	modulation pulse width		25	30	40	μ s
$t_{w(prestore)}$	prestore pulse width		0.05	-	0.5	ms
$t_{w(store)}$	store pulse width	for writing to the OTP cells	95	100	110	ms
t_0	time 0	waiting time after start pulse	20	-	30	ms
t_1	time 1	pulse distance for incrementing the state counter	0.6	0.7	0.8	ms
t_2	time 2	pulse distance for clocking the data register with data = logic 0	1.6	1.7	1.8	ms
t_3	time 3	pulse distance for clocking the data register with data = logic 1	2.6	2.7	2.8	ms
t_4	time 4	waiting time for writing to OTP cells	0.1	0.2	0.3	ms
SR	slew rate	for modulation of the supply voltage	0.5	-	5.0	V/ μ s
R_{mod}	modulation resistance	supply current modulation read-out resistor	18	30	45	k Ω

[1] Program each word once only.

12. Bare die outline

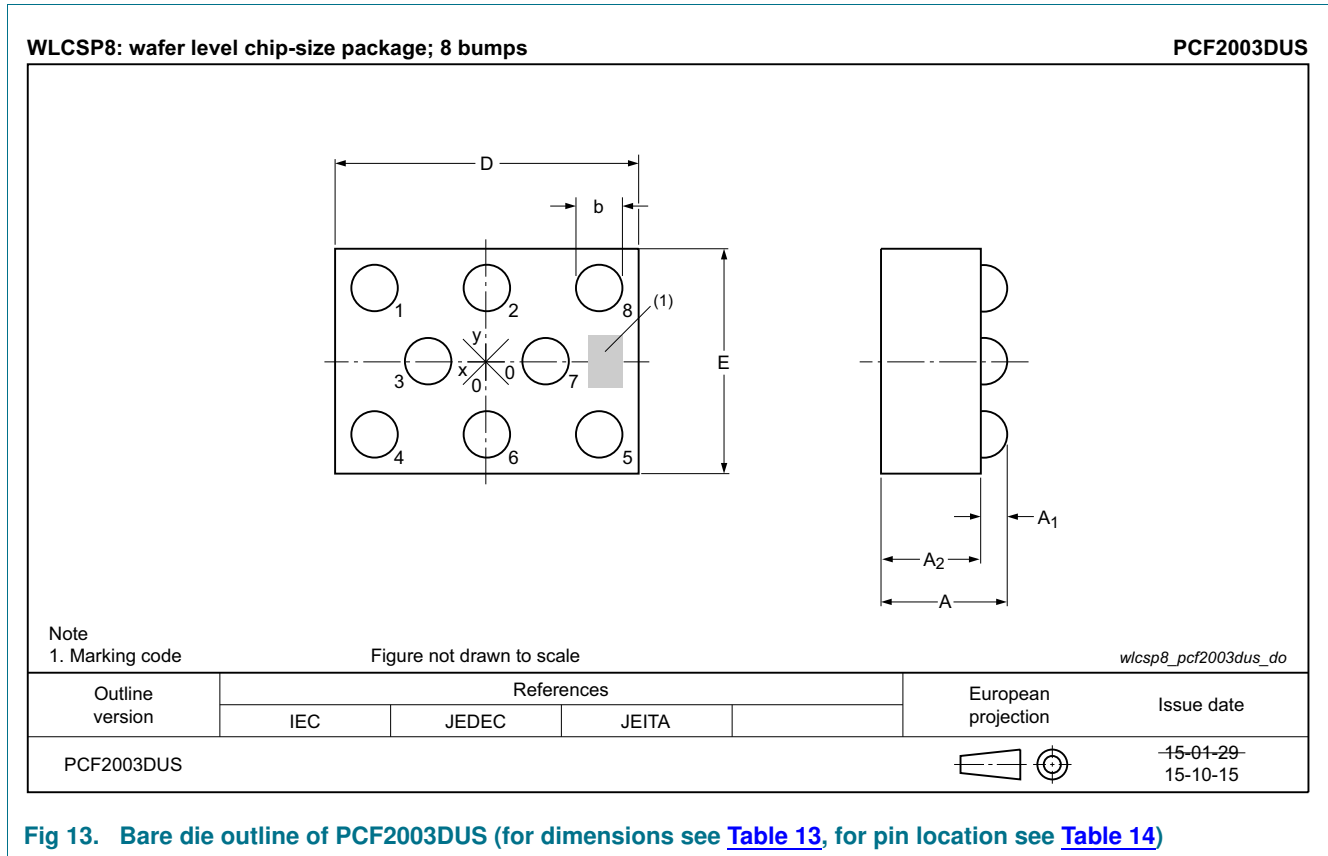

Fig 13. Bare die outline of PCF2003DUS (for dimensions see [Table 13](#), for pin location see [Table 14](#))

Table 13. Dimension of PCF2003US

Original dimensions are in mm.

Unit (mm)	A	A ₁	A ₂	b	D	E
max	-	-	-	-	1.19	0.89
nom	0.53	0.15	0.38	0.20	1.16	0.86
min	-	-	-	-	1.13	0.83

Table 14. Bonding pad description

Symbol	Pin	X ^[1]	Y ^[1]	Type	Description
V _{SS} ^[2]	1	-430	280	supply	ground
i.c. ^[3]	2	0	280	-	internally connected
OSCIN	3	-225	0	input	oscillator input
OSCOU	4	-430	-280	output	oscillator output
V _{DD}	5	430	-280	supply	supply voltage
MOT1	6	0	-280	output	motor 1 output
MOT2	7	225	0	output	motor 2 output
RESET	8	430	280	input	reset input

[1] All coordinates are referenced, in μm , to the center of the die (see [Figure 13](#)).

[2] The substrate (rear side of the chip) is connected to V_{SS}. Therefore the die pad must be either floating or connected to V_{SS}.

[3] Pad i.c. is used for factory tests; in normal operation it should be left open-circuit, and it has an internal pull-down resistance to V_{SS}.

13. Handling information

All input and output pins are protected against ElectroStatic Discharge (ESD) under normal handling. When handling Metal-Oxide Semiconductor (MOS) devices ensure that all normal precautions are taken as described in *JESD625-A*, *IEC 61340-5* or equivalent standards.

14. Packing information

14.1 Tape and reel information

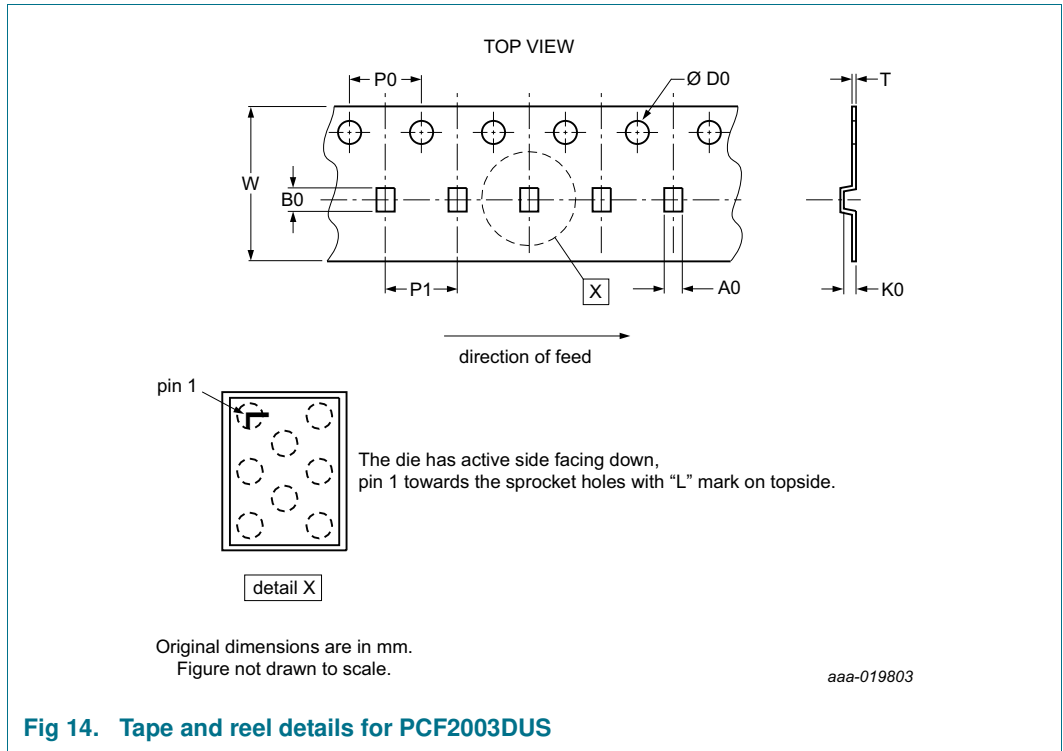

Fig 14. Tape and reel details for PCF2003DUS

Table 15. Carrier tape dimensions of PCF2003DUS

Nominal values with production tolerances.

Symbol	Description	Value	Unit
Compartments			
A0	pocket width in x direction	1.00 ± 0.05	mm
B0	pocket width in y direction	1.30 ± 0.05	mm
K0	pocket depth	0.62 ± 0.05	mm
Overall dimensions			
W	tape width	8	mm
T	tape thickness	0.2 ± 0.02	mm
D0	sprocket hole diameter	1.5	mm
P0	sprocket hole pitch	4 ± 0.1	mm
P1	pocket pitch	4 ± 0.1	mm

15. Soldering of WLCSP packages

15.1 Introduction to soldering WLCSP packages

This text provides a very brief insight into a complex technology. A more in-depth account of soldering WLCSP (Wafer Level Chip-Size Packages) can be found in application note AN10439 "Wafer Level Chip Scale Package" and in application note AN10365 "Surface mount reflow soldering description".

Wave soldering is not suitable for this package.

All NXP WLCSP packages are lead-free.

15.2 Board mounting

Board mounting of a WLCSP requires several steps:

1. Solder paste printing on the PCB
2. Component placement with a pick and place machine
3. The reflow soldering itself

15.3 Reflow soldering

Key characteristics in reflow soldering are:

- Lead-free versus SnPb soldering; note that a lead-free reflow process usually leads to higher minimum peak temperatures (see [Figure 15](#)) than a SnPb process, thus reducing the process window
- Solder paste printing issues, such as smearing, release, and adjusting the process window for a mix of large and small components on one board
- Reflow temperature profile; this profile includes preheat, reflow (in which the board is heated to the peak temperature), and cooling down. It is imperative that the peak temperature is high enough for the solder to make reliable solder joints (a solder paste characteristic) while being low enough that the packages and/or boards are not damaged. The peak temperature of the package depends on package thickness and volume and is classified in accordance with [Table 16](#).

Table 16. Lead-free process (from J-STD-020D)

Package thickness (mm)	Package reflow temperature (°C)		
	Volume (mm ³)		
	< 350	350 to 2000	> 2000
< 1.6	260	260	260
1.6 to 2.5	260	250	245
> 2.5	250	245	245

Moisture sensitivity precautions, as indicated on the packing, must be respected at all times.

Studies have shown that small packages reach higher temperatures during reflow soldering, see [Figure 15](#).

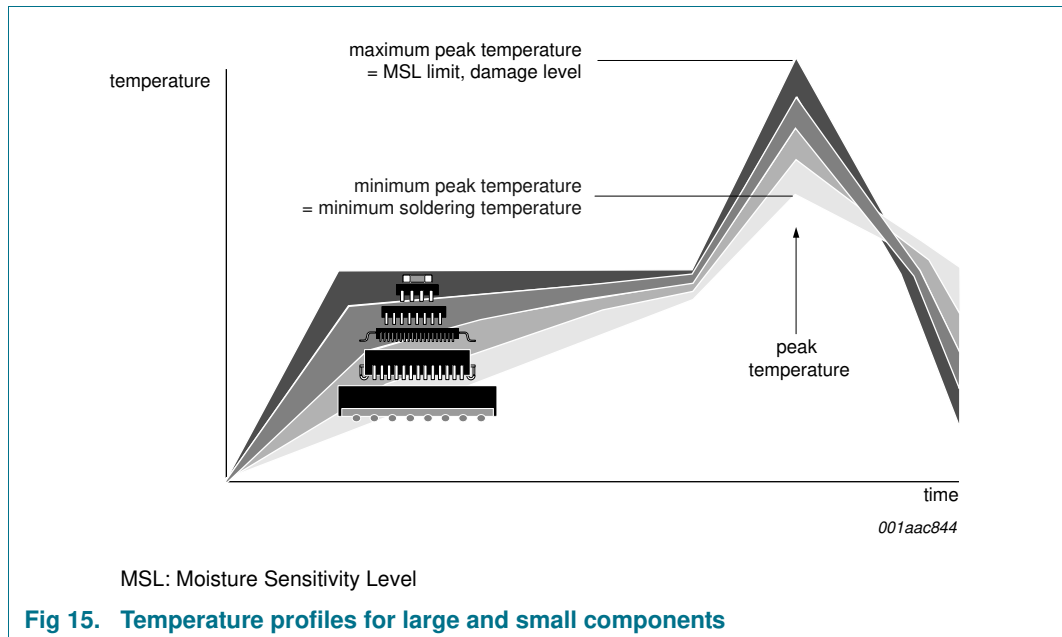

For further information on temperature profiles, refer to application note *AN10365* “Surface mount reflow soldering description”.

15.3.1 Stand off

The stand off between the substrate and the chip is determined by:

- The amount of printed solder on the substrate
- The size of the solder land on the substrate
- The bump height on the chip

The higher the stand off, the better the stresses are released due to TEC (Thermal Expansion Coefficient) differences between substrate and chip.

15.3.2 Quality of solder joint

A flip-chip joint is considered to be a good joint when the entire solder land has been wetted by the solder from the bump. The surface of the joint should be smooth and the shape symmetrical. The soldered joints on a chip should be uniform. Voids in the bumps after reflow can occur during the reflow process in bumps with high ratio of bump diameter to bump height, i.e. low bumps with large diameter. No failures have been found to be related to these voids. Solder joint inspection after reflow can be done with X-ray to monitor defects such as bridging, open circuits and voids.

15.3.3 Rework

In general, rework is not recommended. By rework we mean the process of removing the chip from the substrate and replacing it with a new chip. If a chip is removed from the substrate, most solder balls of the chip will be damaged. In that case it is recommended not to re-use the chip again.

Device removal can be done when the substrate is heated until it is certain that all solder joints are molten. The chip can then be carefully removed from the substrate without damaging the tracks and solder lands on the substrate. Removing the device must be done using plastic tweezers, because metal tweezers can damage the silicon. The surface of the substrate should be carefully cleaned and all solder and flux residues and/or underfill removed. When a new chip is placed on the substrate, use the flux process instead of solder on the solder lands. Apply flux on the bumps at the chip side as well as on the solder pads on the substrate. Place and align the new chip while viewing with a microscope. To reflow the solder, use the solder profile shown in application note AN10365 "Surface mount reflow soldering description".

15.3.4 Cleaning

Cleaning can be done after reflow soldering.

16. Abbreviations

Table 17. Abbreviations

Acronym	Description
CMOS	Complementary Metal Oxide Semiconductor
HBM	Human Body Model
LSB	Least Significant Bit
MM	Machine Model
MSB	Most Significant Bit
OTP	One Time Programmable

17. References

- [1] **AN10365** — Surface mount reflow soldering description
- [2] **AN10439** — Wafer Level Chip Size Package
- [3] **AN10706** — Handling bare die
- [4] **IEC 60134** — Rating systems for electronic tubes and valves and analogous semiconductor devices
- [5] **IEC 61340-5** — Protection of electronic devices from electrostatic phenomena
- [6] **JESD22-A114** — Electrostatic Discharge (ESD) Sensitivity Testing Human Body Model (HBM)
- [7] **JESD22-A115** — Electrostatic Discharge (ESD) Sensitivity Testing Machine Model (MM)
- [8] **JESD78** — IC Latch-Up Test
- [9] **JESD625-A** — Requirements for Handling Electrostatic-Discharge-Sensitive (ESDS) Devices
- [10] **UM10569** — Store and transport requirements

18. Revision history

Table 18. Revision history

Document ID	Release date	Data sheet status	Change notice	Supersedes
PCF2003 v.1	20151020	Product data sheet	-	-