



Chipsmall Limited consists of a professional team with an average of over 10 year of expertise in the distribution of electronic components. Based in Hongkong, we have already established firm and mutual-benefit business relationships with customers from,Europe,America and south Asia,supplying obsolete and hard-to-find components to meet their specific needs.

With the principle of "Quality Parts,Customers Priority,Honest Operation,and Considerate Service",our business mainly focus on the distribution of electronic components. Line cards we deal with include Microchip,ALPS,ROHM,Xilinx,Pulse,ON,Everlight and Freescale. Main products comprise IC,Modules,Potentiometer,IC Socket,Relay,Connector.Our parts cover such applications as commercial,industrial, and automotives areas.

We are looking forward to setting up business relationship with you and hope to provide you with the best service and solution. Let us make a better world for our industry!



## Contact us

Tel: +86-755-8981 8866 Fax: +86-755-8427 6832

Email & Skype: info@chipsmall.com Web: www.chipsmall.com

Address: A1208, Overseas Decoration Building, #122 Zhenhua RD., Futian, Shenzhen, China





# PCF8583

## Clock and calendar with 240 x 8-bit RAM

Rev. 06 — 6 October 2010

Product data sheet

## 1. General description

---

The PCF8583 is a clock and calendar chip, based on a 2048 bit static CMOS<sup>1</sup> RAM organized as 256 words by 8 bits. Addresses and data are transferred serially via the two-line bidirectional I<sup>2</sup>C-bus. The built-in word address register is incremented automatically after each written or read data byte. Address pin A0 is used for programming the hardware address, allowing the connection of two devices to the bus without additional hardware.

The built-in 32.768 kHz oscillator circuit and the first 8 bytes of the RAM are used for the clock, calendar, and counter functions. The next 8 bytes can be programmed as alarm registers or used as free RAM space. The remaining 240 bytes are free RAM locations.

## 2. Features and benefits

---

- I<sup>2</sup>C-bus interface operating supply voltage: 2.5 V to 6 V
- Clock operating supply voltage 1.0 V to 6.0 V at 0 °C to +70 °C
- 240 × 8-bit low-voltage RAM
- Data retention voltage: 1.0 V to 6.0 V
- Operating current (at f<sub>SCL</sub> = 0 Hz): max 50 μA
- Clock function with four year calendar
- Universal timer with alarm and overflow indication
- 24 hour or 12 hour format
- 32.768 kHz or 50 Hz time base
- Serial input and output bus (I<sup>2</sup>C-bus)
- Automatic word address incrementing
- Programmable alarm, timer, and interrupt function
- Slave addresses: A1h or A3h for reading, A0h or A2h for writing

---

1. The definition of the abbreviations and acronyms used in this data sheet can be found in [Section 14](#).



### 3. Ordering information

Table 1. Ordering information

Type number	Package		Version
	Name	Description	
PCF8583P	DIP8	plastic dual in-line package; 8 leads (300 mil)	SOT97-1
PCF8583T	SO8	plastic small outline package; 8 leads; body width 7.5 mm	SOT176-1
PCF8583BS	HVQFN20	plastic thermal enhanced very thin quad flat package; no leads; 20 terminals; body 5 × 5 × 0.85 mm	SOT662-1

### 4. Marking

Table 2. Marking codes

Type number	Marking code
PCF8583P	PCF8583P
PCF8583T	8583T
PCF8583BS	8583S

### 5. Block diagram

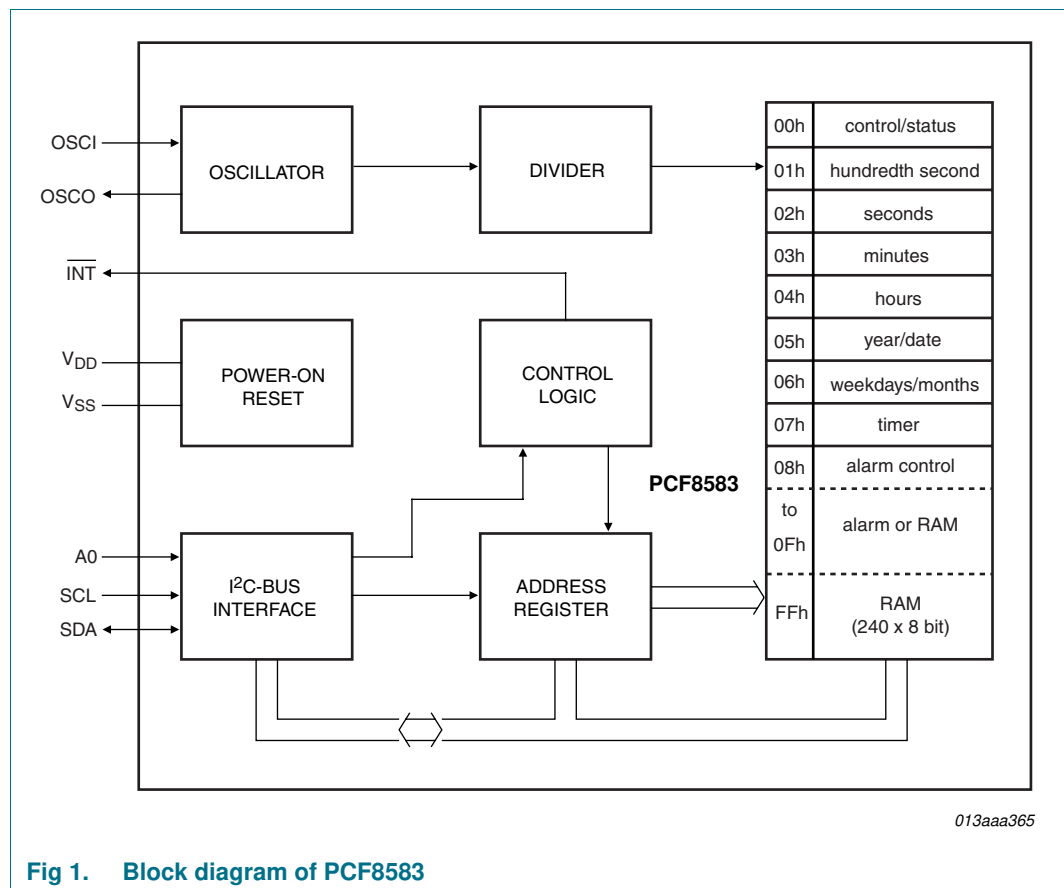
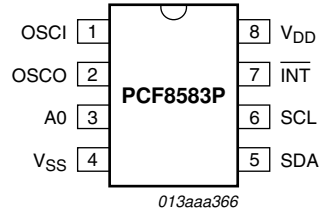


Fig 1. Block diagram of PCF8583

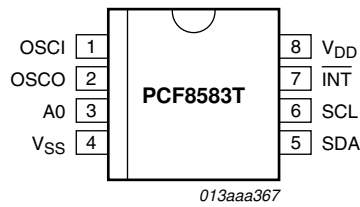
## 6. Pinning information

### 6.1 Pinning



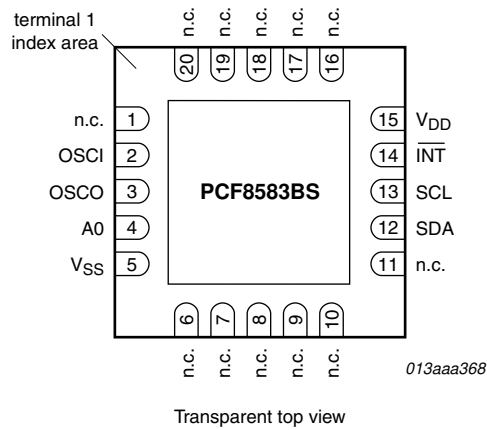
Top view. For mechanical details, see [Figure 24](#).

**Fig 2. Pin configuration for DIP8 (PCF8583P)**



Top view. For mechanical details, see [Figure 25](#).

**Fig 3. Pin configuration for SO8 (PCF8583T)**



For mechanical details, see [Figure 26](#).

**Fig 4. Pin configuration for HVQFN20 (PCF8583BS)**

## 6.2 Pin description

**Table 3.** Pin description

Symbol	Pin			Type	Description
	DIP8 (PCF8583P)	SO8 (PCF8583T)	HVQFN20 (PCF8583BS)		
OSCI	1	1	2	input	oscillator input, 50 Hz or event-pulse input
OSCO	2	2	3	output	oscillator output
A0	3	3	4	input	address input
V <sub>SS</sub>	4	4	5 <sup>[1]</sup>	supply	ground supply voltage
SDA	5	5	12	input/output	serial data line
SCL	6	6	13	input	serial clock line
$\overline{\text{INT}}$	7	7	14	output	open-drain interrupt output (active LOW)
V <sub>DD</sub>	8	8	15	supply	supply voltage
n.c.	-	-	1, 6 to 11, 16 to 20	-	not connected; do not connect and do not use as feed through

[1] The die paddle (exposed pad) is connected to V<sub>SS</sub> and should be electrically isolated.



## 7. Functional description

The PCF8583 contains a 256 by 8 bit RAM with an 8 bit auto-increment address register, an on-chip 32.768 kHz oscillator circuit, a frequency divider, a serial two-line bidirectional I<sup>2</sup>C-bus interface, and a Power-On Reset (POR) circuit.

The first 16 bytes of the RAM (memory addresses 00h to 0Fh) are designed as addressable 8 bit parallel special function registers. The first register (memory address 00h) is used as a control and status register. The memory addresses 01h to 07h are used as counters for the clock function. The memory addresses 08h to 0Fh may be programmed as alarm registers or used as free RAM locations, when the alarm is disabled.

### 7.1 Counter function modes

When the control and status register is programmed, a 32.768 kHz clock mode, a 50 Hz clock mode or an event-counter mode can be selected.

In the clock modes the hundredths of a second, seconds, minutes, hours, date, month (four year calendar) and weekday are stored in a Binary Coded Decimal (BCD) format. The timer register stores up to 99 days. The event counter mode is used to count pulses applied to the oscillator input (OSCO left open-circuit). The event counter stores up to 6 digits of data.

When one of the counters is read (memory locations 01h to 07h), the contents of all counters are strobed into capture latches at the beginning of a read cycle. Therefore, faulty reading of the counter during a carry condition is prevented.

When a counter is written, other counters are not affected.

### 7.2 Alarm function modes

By setting the alarm enable bit of the control and status register the alarm control register (address 08h) is activated.

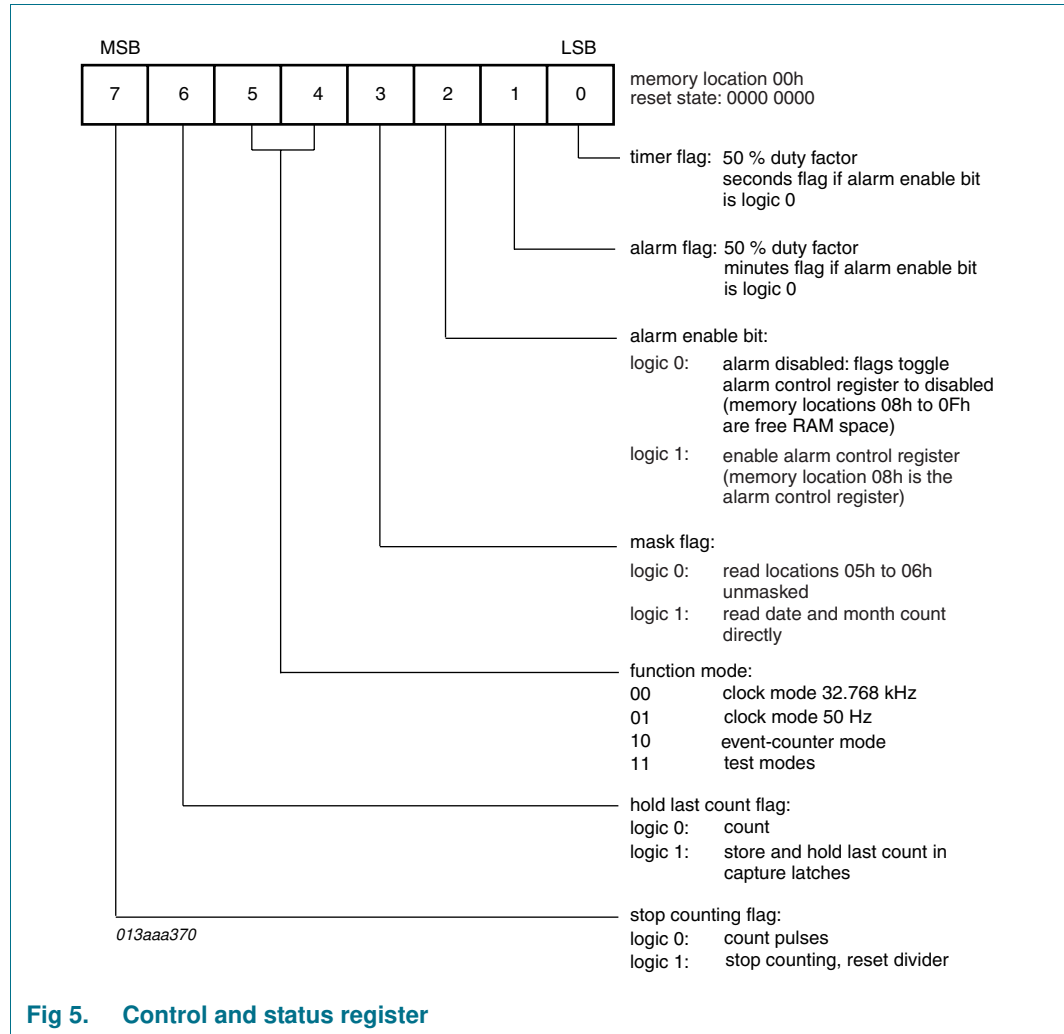
By setting the alarm control register, a dated alarm, a daily alarm, a weekday alarm, or a timer alarm may be programmed. In the clock modes, the timer register (address 07h) may be programmed to count hundredths of a second, seconds, minutes, hours, or days. Days are counted when an alarm is not programmed.

Whenever an alarm event occurs the alarm flag of the control and status register is set. A timer alarm event will set the alarm flag and an overflow condition of the timer will set the timer flag. The open-drain interrupt output is switched on (active LOW) when the alarm or timer flag is set (enabled). The flags remain set until directly reset by a write operation.

When the alarm is disabled (bit 2 of control and status register set logic 0) the alarm registers at addresses 08h to 0Fh may be used as free RAM.

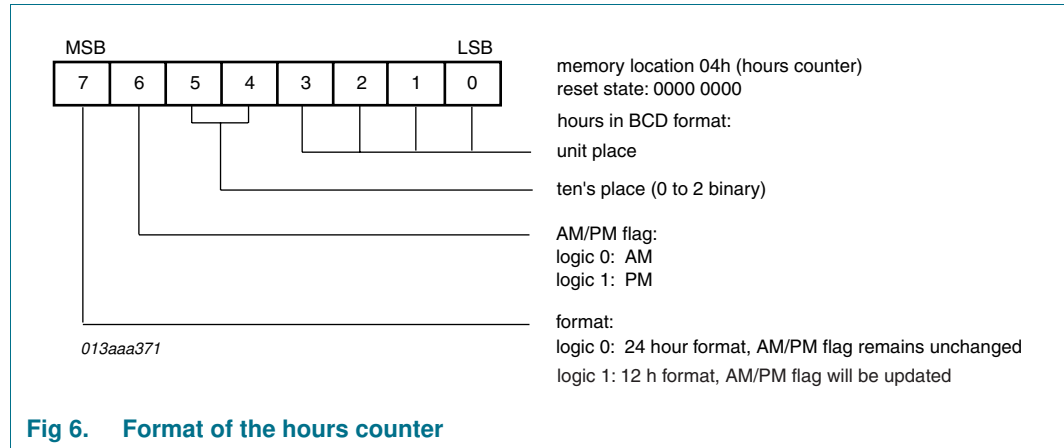
### 7.3 Control and status register

The control and status register is defined as the memory location 00h with free access for reading and writing via the I<sup>2</sup>C-bus. All functions and options are controlled by the contents of the control and status register (see [Figure 5](#)).



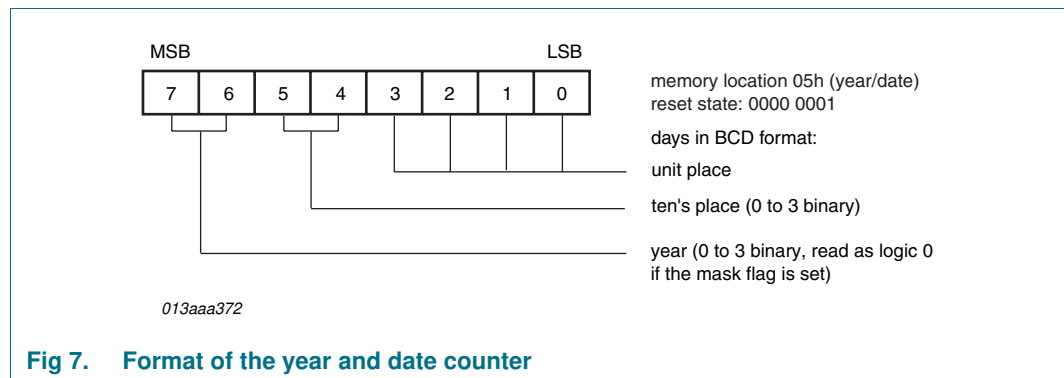
### 7.4 Counter registers

The format for 24 hour or 12 hour clock modes can be selected by setting the most significant bit of the hours counter register. The format of the hours counter is shown in [Figure 6](#).

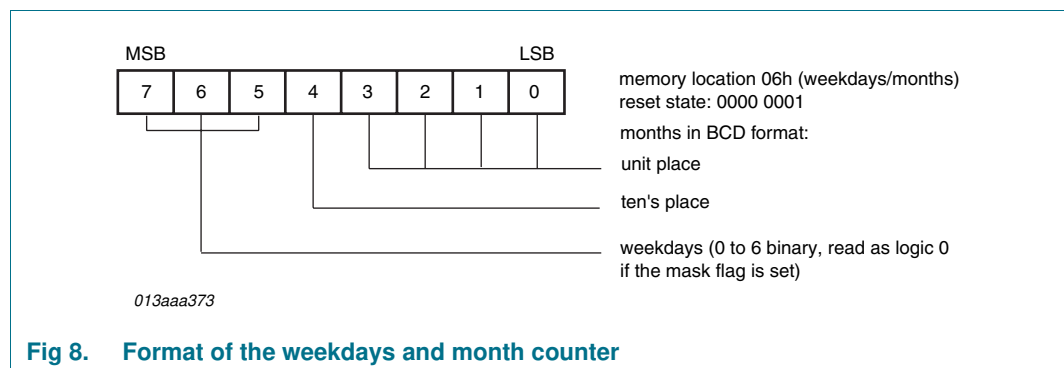


**Fig 6. Format of the hours counter**

The year and date are stored in memory location 05h (see [Figure 7](#)). The weekdays and months are in memory location 06h (see [Figure 8](#)).



**Fig 7. Format of the year and date counter**



**Fig 8. Format of the weekdays and month counter**

When reading these memory locations the year and weekdays are masked out when the mask flag of the control and status register is set. This allows the user to read the date and month count directly. In the event-counter mode, events are stored in BCD format. D5 is the most significant and D0 the least significant digit. The divider is by-passed.



In the different modes the counter registers are programmed and arranged as shown in [Figure 9](#). Counter cycles are listed in [Table 4](#).

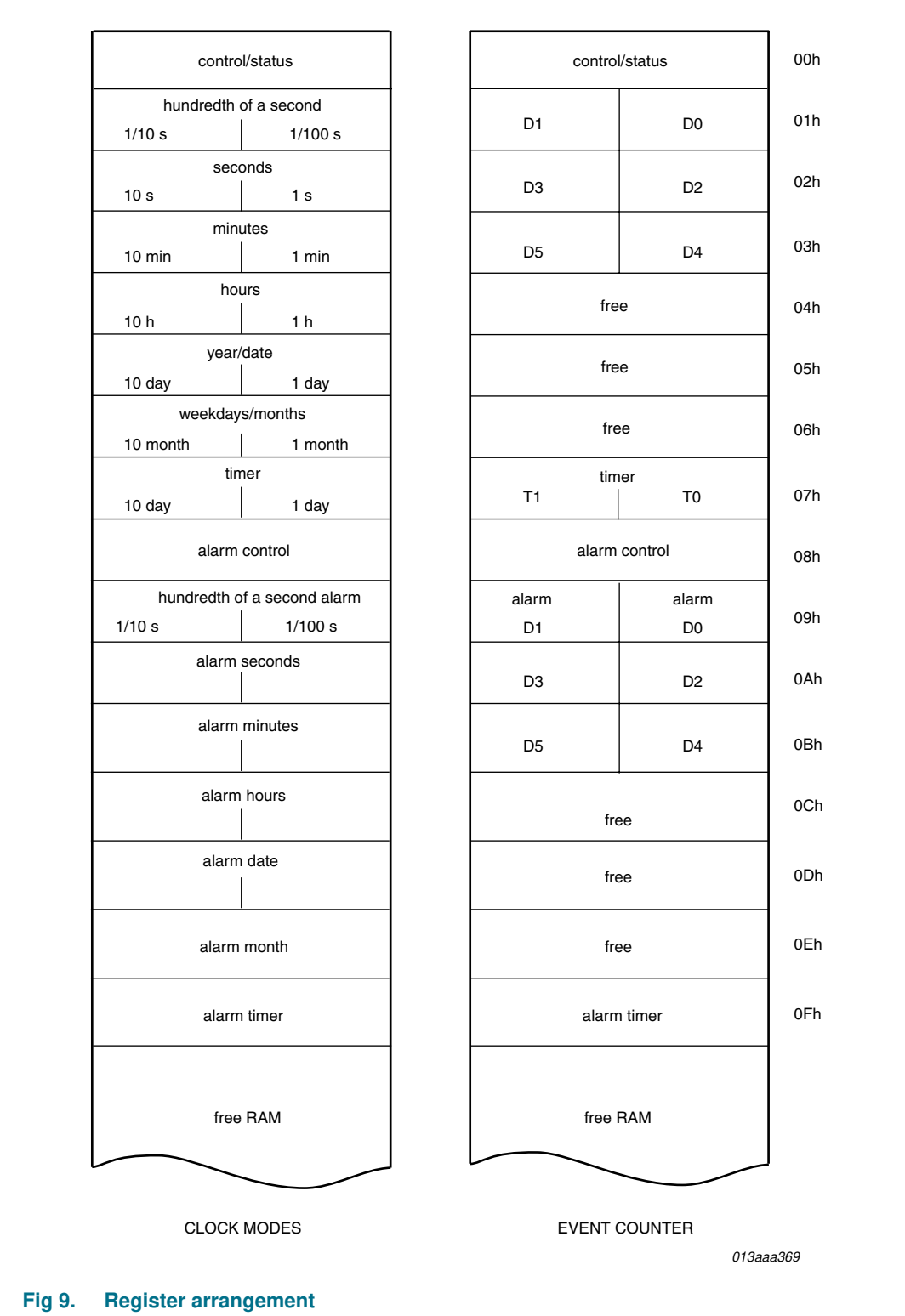


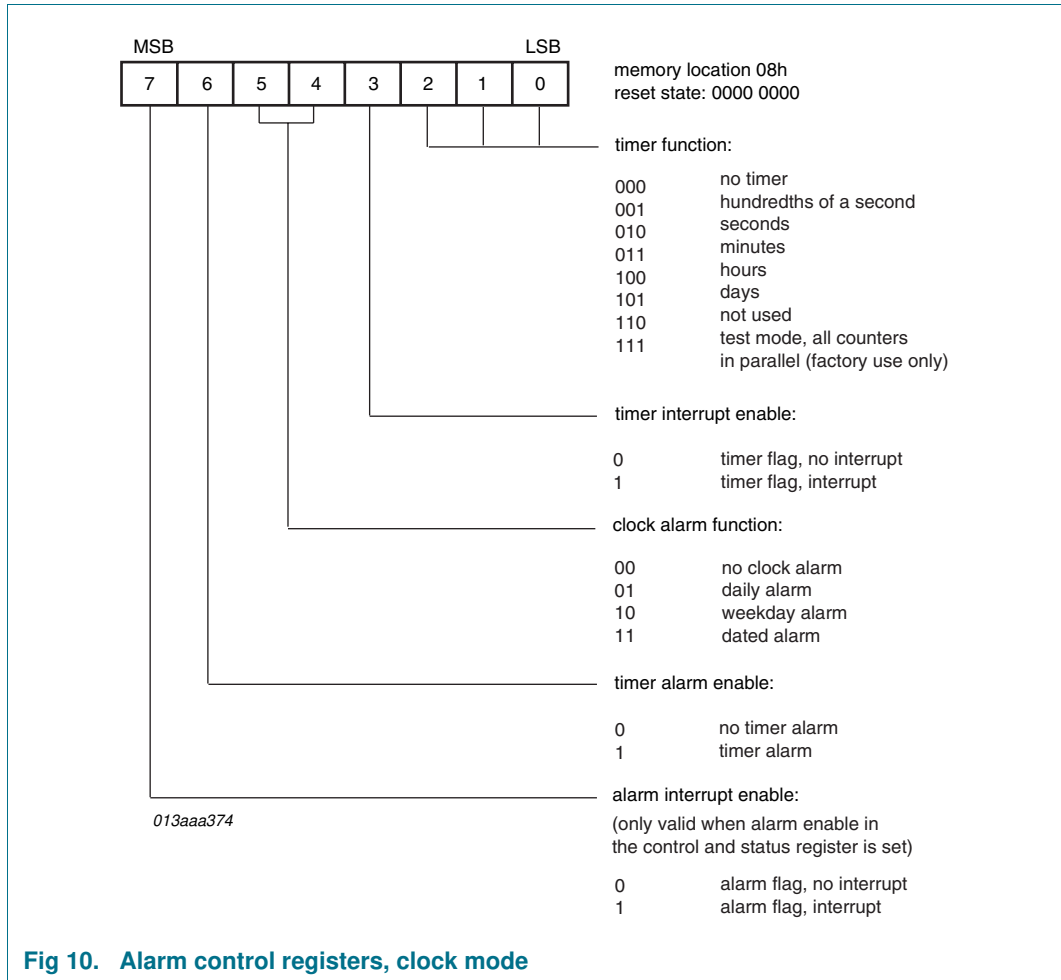
Fig 9. Register arrangement

**Table 4. Cycle length of the time counters, clock modes**

Unit	Counting cycle	Carry to next unit	Contents of month calendar
hundredths of a second	00 to 99	99 to 00	-
seconds	00 to 59	59 to 00	-
minutes	00 to 59	59 to 00	-
hours (24)	00 to 23	23 to 00	-
hours (12)	12 am	-	-
	01 am to 11 am	-	-
	12 pm	-	-
	01 pm to 11 pm	11 pm to 12 am	-
date	01 to 31	31 to 01	1, 3, 5, 7, 8, 10, and 12
	01 to 30	30 to 01	4, 6, 9, and 11
	01 to 29	29 to 01	2, year = 0
	01 to 28	28 to 01	2, year = 1, 2, and 3
months	01 to 12	12 to 01	-
year	0 to 3	-	-
weekdays	0 to 6	6 to 0	-
timer	00 to 99	no carry	-

## 7.5 Alarm control register

When the alarm enable bit of the control and status register is set (address 00h, bit 2) the alarm control register (address 08h) is activated. All alarm, timer, and interrupt output functions are controlled by the contents of the alarm control register (see [Figure 10](#)).

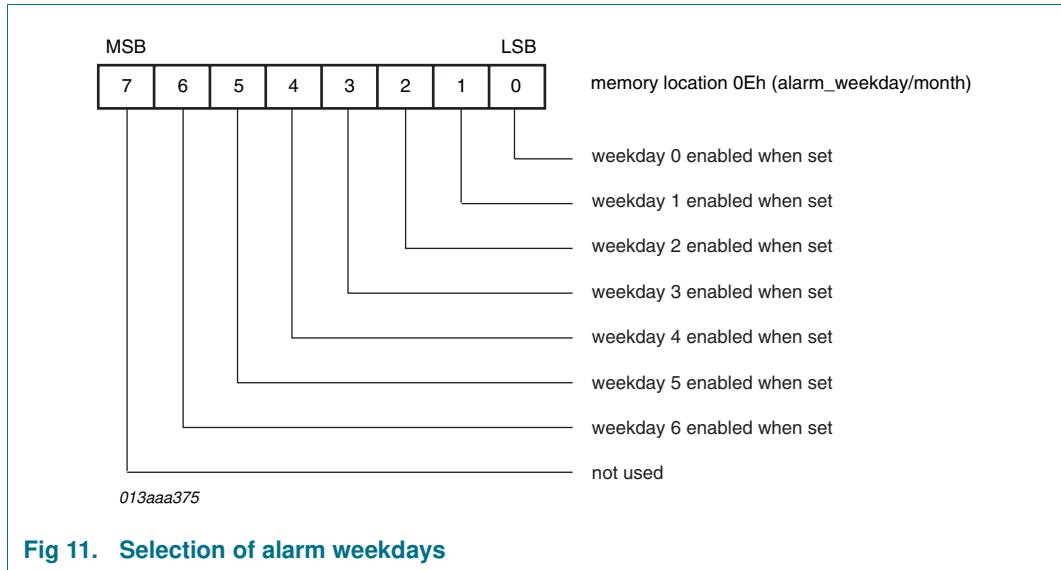


## 7.6 Alarm registers

All alarm registers are allocated with a constant address offset of 08h to the corresponding counter registers (see [Figure 9](#)).

An alarm signal is generated when the contents of the alarm registers match bit-by-bit the contents of the involved counter registers. The year and weekday bits are ignored in a dated alarm. A daily alarm ignores the month and date bits. When a weekday alarm is selected, the contents of the alarm weekday and month register selects the weekdays on which an alarm is activated (see [Figure 11](#)).

**Remark:** In the 12 hour mode, bits 6 and 7 of the alarm hours register must be the same as the hours counter.



### 7.7 Timer

The timer (location 07h) is enabled by setting the control and status register to XX0X X1XX. The timer counts up from 0 (or a programmed value) to 99. On overflow, the timer resets to 0. The timer flag (LSB of control and status register) is set on overflow of the timer. This flag must be reset by software. The inverted value of this flag can be transferred to the external interrupt by setting bit 3 of the alarm control register.

Additionally, a timer alarm can be programmed by setting the timer alarm enable (bit 6 of the alarm control register). When the value of the timer equals a pre-programmed value in the alarm timer register (location 0Fh), the alarm flag is set (bit 1 of the control and status register). The inverted value of the alarm flag can be transferred to the external interrupt by enabling the alarm interrupt (bit 6 of the alarm control register).

Resolution of the timer is programmed via the 3 LSBs of the alarm control register (see [Figure 12](#)).

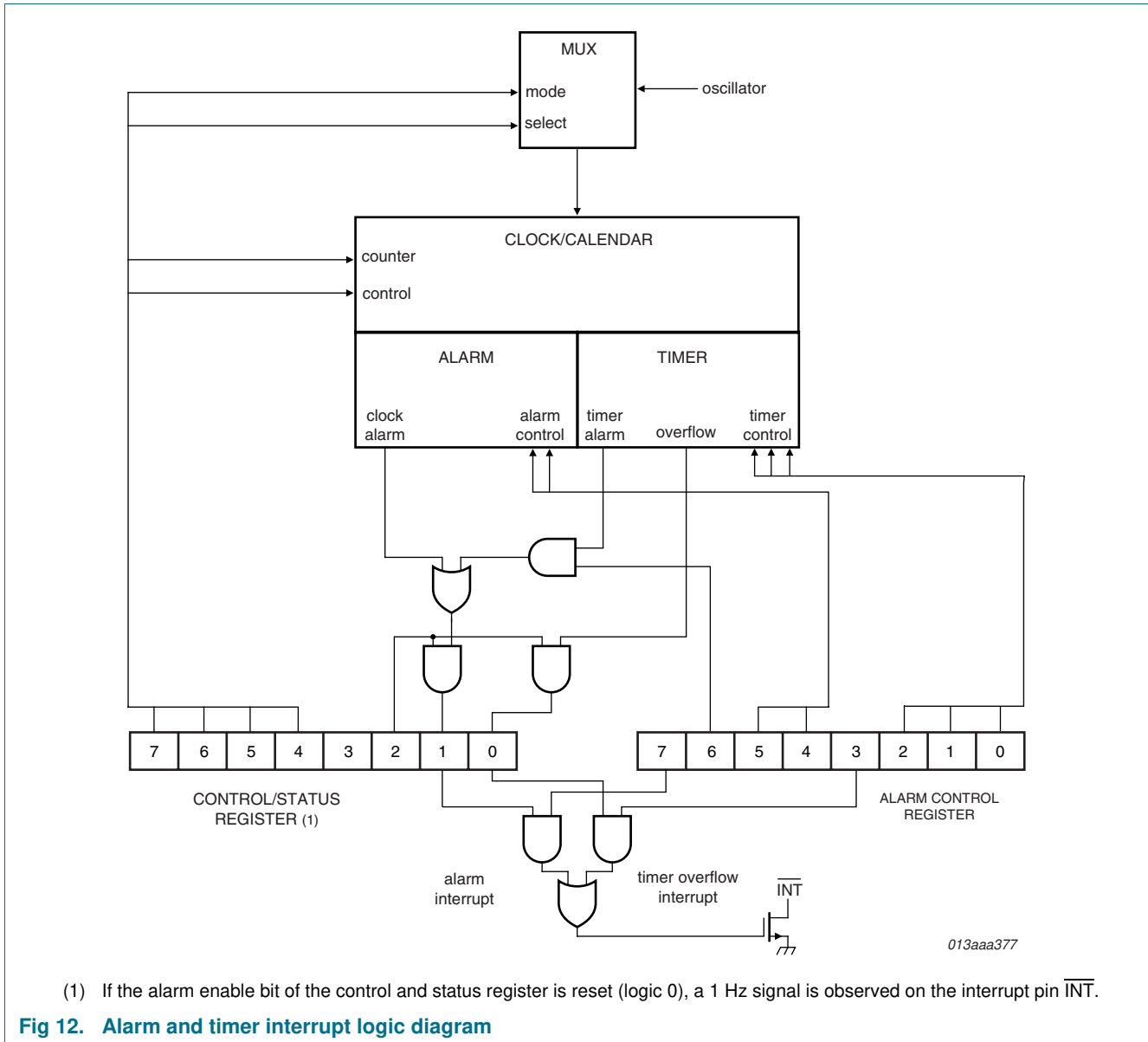


Fig 12. Alarm and timer interrupt logic diagram

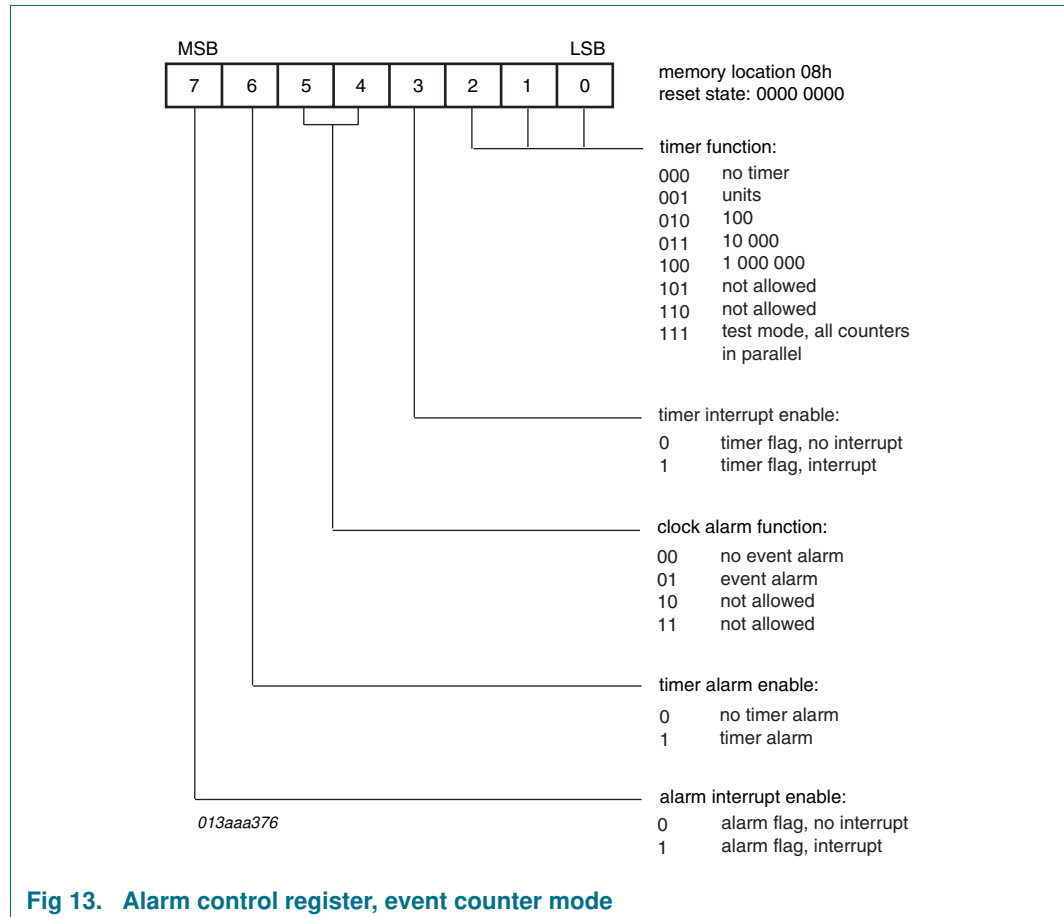
### 7.8 Event counter mode

Event counter mode is selected by bits 4 and 5 which are logic 10 in the control and status register. The event counter mode is used to count pulses externally applied to the oscillator input (OSCO left open-circuit).

The event counter stores up to 6 digits of data, which are stored as 6 hexadecimal values located in the registers 1h, 2h, and 3h. Therefore, up to 1 million events may be recorded.

An event counter alarm occurs when the event counter registers match the value programmed in the registers 9h, Ah, and Bh, and the event alarm is enabled (bits 4 and 5 which are logic 01 in the alarm control register). In this event, the alarm flag (bit 1 of the control and status register) is set. The inverted value of this flag can be transferred to the interrupt pin (pin 7) by setting the alarm interrupt enable in the alarm control register. In

this mode, the timer (location 07h) increments once for every one, one hundred, ten thousand, or 1 million events, depending on the value programmed in bits 0, 1 and 2 of the alarm control register. In all other events, the timer functions are as in the clock mode.



### 7.9 Interrupt output

The conditions for activating the output  $\overline{INT}$  (active LOW) are determined by appropriate programming of the alarm control register. These conditions are clock alarm, timer alarm, timer overflow, and event counter alarm. An interrupt occurs when the alarm flag or the timer flag is set, and the corresponding interrupt is enabled. In all events, the interrupt is cleared only by software resetting of the flag which initiated the interrupt.

In the clock mode, if the alarm enable is not activated (alarm enable bit of the control and status register is logic 0), the interrupt output toggles at 1 Hz with a 50 % duty cycle (may be used for calibration). This is the default power-on state of the device. The OFF voltage of the interrupt output may exceed the supply voltage, up to a maximum of 6.0 V. A logic diagram of the interrupt output is shown in [Figure 12](#).

### 7.10 Oscillator and divider

A 32.768 kHz quartz crystal has to be connected to OSC1 and OSC0. A trimmer capacitor between OSC1 and  $V_{DD}$  is used for tuning the oscillator (see [Section 11.1](#)). A 100 Hz clock signal is derived from the quartz oscillator for the clock counters.



In the 50 Hz clock mode or event-counter mode the oscillator is disabled and the oscillator input is switched to a high-impedance state. This allows the user to feed the 50 Hz reference frequency or an external high speed event signal into the input OSCI.

### 7.11 Initialization

When power-on occurs the I<sup>2</sup>C-bus interface, the control and status register and all clock counters are reset. The device starts time-keeping in the 32.768 kHz clock mode with the 24 hour format on the first of January at 0.00.00:00. A 1 Hz square wave with 50 % duty cycle appears at the interrupt output pin (starts HIGH).

The stop counting flag of the control and status register must be set before loading the actual time into the counters. Loading of illegal states leads to a temporary clock malfunction.

## 8. Characteristics of the I<sup>2</sup>C-bus

### 8.1 Characteristics

The I<sup>2</sup>C-bus is for bidirectional, two-line communication between different ICs or modules. The two lines are a Serial Data line (SDA) and a Serial Clock Line (SCL). Both lines must be connected to a positive supply via a pull-up resistor. Data transfer is initiated only when the bus is not busy.

#### 8.1.1 Bit transfer

One data bit is transferred during each clock pulse (see [Figure 14](#)). The data on the SDA line must remain stable during the HIGH period of the clock pulse as changes in the data line at this time are interpreted as a control signal.

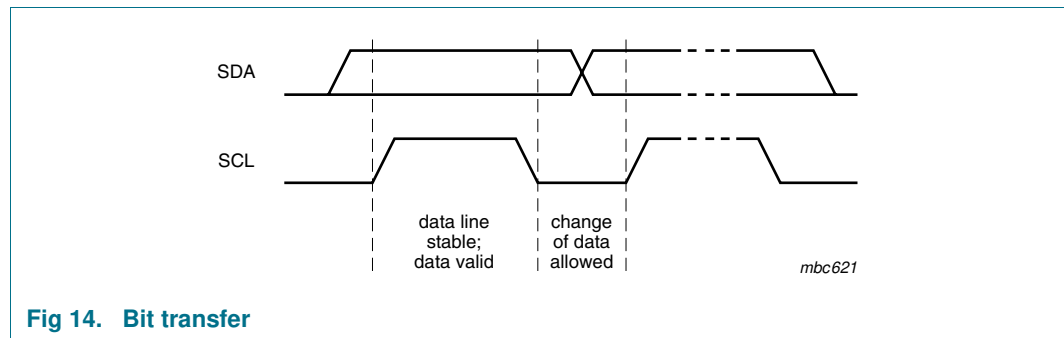


Fig 14. Bit transfer

#### 8.1.2 Start and stop conditions

Both data and clock lines remain HIGH when the bus is not busy.

A HIGH-to-LOW transition of the data line while the clock is HIGH is defined as the START condition - S.

A LOW-to-HIGH transition of the data line while the clock is HIGH is defined as the STOP condition - P (see [Figure 15](#)).

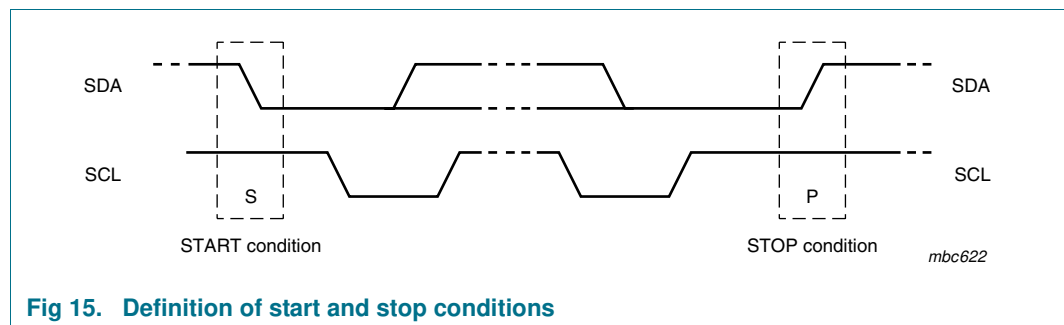


Fig 15. Definition of start and stop conditions

#### 8.1.3 System configuration

A device generating a message is a transmitter; a device receiving a message is the receiver (see [Figure 16](#)). The device that controls the message is the master; and the devices which are controlled by the master are the slaves.

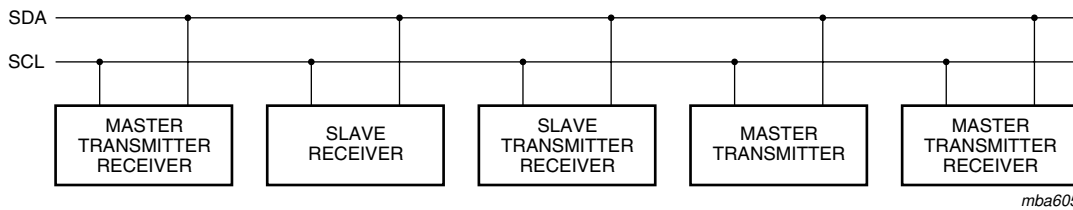


Fig 16. System configuration

8.1.4 Acknowledge

The number of data bytes transferred between the START and STOP conditions from transmitter to receiver is unlimited. Each byte of eight bits is followed by an acknowledge cycle.

- A slave receiver, which is addressed, must generate an acknowledge after the reception of each byte.
- Also a master receiver must generate an acknowledge after the reception of each byte that has been clocked out of the slave transmitter.
- The device that acknowledges must pull-down the SDA line during the acknowledge clock pulse, so that the SDA line is stable LOW during the HIGH period of the acknowledge related clock pulse (set-up and hold times must be taken into consideration).
- A master receiver must signal an end of data to the transmitter by not generating an acknowledge on the last byte that has been clocked out of the slave. In this event, the transmitter must leave the data line HIGH to enable the master to generate a STOP condition.

Acknowledgement on the I<sup>2</sup>C-bus is illustrated in [Figure 17](#).

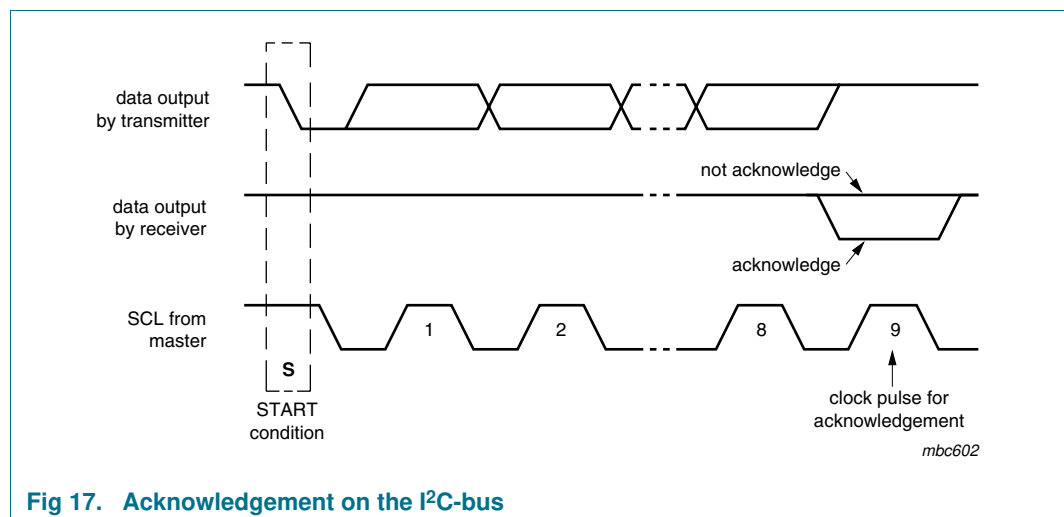


Fig 17. Acknowledgement on the I<sup>2</sup>C-bus

## 8.2 I<sup>2</sup>C-bus protocol

### 8.2.1 Addressing

Before any data is transmitted on the I<sup>2</sup>C-bus, the device which must respond is addressed first. The addressing is always carried out with the first byte transmitted after the start procedure.

The clock and calendar acts as a slave receiver or slave transmitter. The clock signal SCL is only an input signal but the data signal SDA is a bidirectional line.

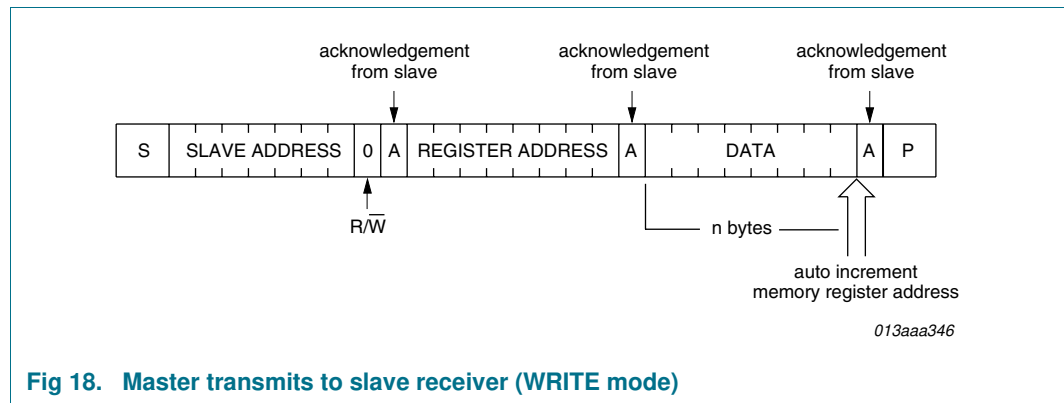
The clock and calendar slave address is shown in [Table 5](#). Bit A0 corresponds to hardware address pin A0. Connecting this pin to V<sub>DD</sub> or V<sub>SS</sub> allows the device to have one of two different addresses.

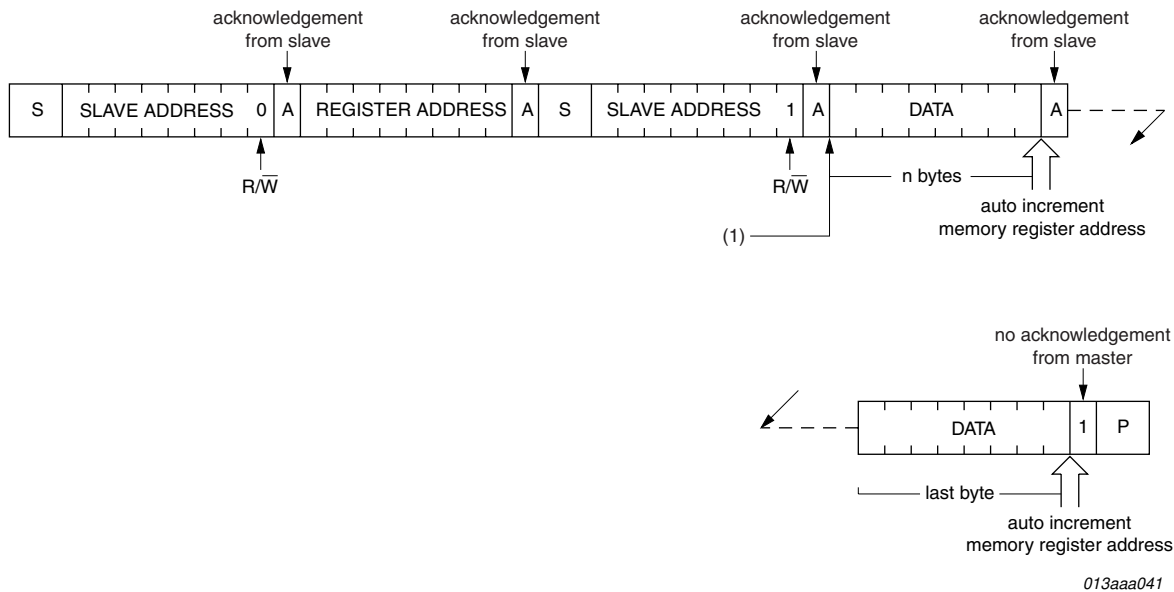
**Table 5. I<sup>2</sup>C slave address byte**

Bit	Slave address							0 LSB
	7 MSB	6	5	4	3	2	1	
	1	0	1	0	0	0	A0	R/ $\bar{W}$

### 8.2.2 Clock and calendar READ or WRITE cycles

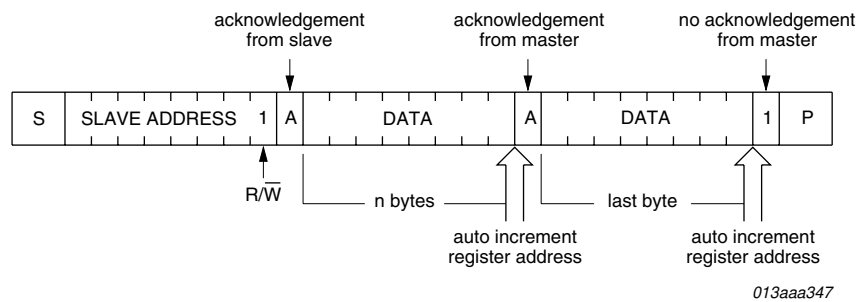
The I<sup>2</sup>C-bus configuration for the different PCF8583 READ and WRITE cycles is shown in [Figure 18](#), [Figure 19](#) and [Figure 20](#).





(1) At this moment master transmitter becomes master receiver and PCF8583 slave receiver becomes slave transmitter.

**Fig 19. Master reads after setting word address (write word address; READ data)**



**Fig 20. Master reads slave immediately after first byte (READ mode)**

## 9. Limiting values

**Table 6. Limiting values**

*In accordance with the Absolute Maximum Rating System (IEC 60134).*

Symbol	Parameter	Conditions	Min	Max	Unit	
V <sub>DD</sub>	supply voltage		-0.8	+7.0	V	
I <sub>DD</sub>	supply current		-	50	mA	
I <sub>SS</sub>	ground supply current		-	50	mA	
V <sub>I</sub>	input voltage		-0.8	V <sub>DD</sub> + 0.8	V	
I <sub>I</sub>	input current		-	10	mA	
I <sub>O</sub>	output current		-	10	mA	
P <sub>tot</sub>	total power dissipation		-	300	mW	
P <sub>o</sub>	output power		-	50	mW	
V <sub>ESD</sub>	electrostatic discharge voltage	HBM	[1]	-	±3000	V
		MM	[2]	-	±200	V
I <sub>lu</sub>	latch-up current		[3]	-	100	mA
T <sub>stg</sub>	storage temperature		[4]	-65	+150	°C
T <sub>amb</sub>	ambient temperature	operating device		-40	+85	°C

[1] Pass level; Human Body Model (HBM), according to [Ref. 5 "JESD22-A114"](#).

[2] Pass level; Machine Model (MM), according to [Ref. 6 "JESD22-A115"](#).

[3] Pass level; latch-up testing according to [Ref. 7 "JESD78"](#) at maximum ambient temperature (T<sub>amb(max)</sub>).

[4] According to the NXP store and transport requirements (see [Ref. 9 "NX3-00092"](#)) the devices have to be stored at a temperature of +8 °C to +45 °C and a humidity of 25 % to 75 %. For long term storage products deviant conditions are described in that document.



## 10. Characteristics

### 10.1 Static characteristics

**Table 7. Static characteristics**

$V_{DD} = 2.5\text{ V to }6.0\text{ V}$ ;  $V_{SS} = 0\text{ V}$ ;  $T_{amb} = -40\text{ °C to }+85\text{ °C}$  unless otherwise specified.

Symbol	Parameter	Conditions	Min	Typ <sup>[1]</sup>	Max	Unit	
$V_{DD}$	supply voltage	operating mode					
		I <sup>2</sup> C-bus active	2.5	-	6.0	V	
		I <sup>2</sup> C-bus inactive	1.0	-	6.0	V	
		quartz oscillator					
		$T_{amb} = 0\text{ °C to }+70\text{ °C}$	[2]	1.0	-	6.0	V
$I_{DD}$	supply current	operating mode					
		$f_{SCL} = 100\text{ kHz}$ clock mode	[3]	-	-	200	$\mu\text{A}$
		clock mode; $f_{SCL} = 0\text{ Hz}$					
		$V_{DD} = 5.0\text{ V}$	[4]	-	10	50	$\mu\text{A}$
		$V_{DD} = 1.0\text{ V}$	[4]	-	2	10	$\mu\text{A}$
		data retention; $f_{OSCI} = 0\text{ Hz}$ ; $V_{DD} = 1.0\text{ V}$					
		$T_{amb} = -40\text{ °C to }+85\text{ °C}$	-	-	-	5	$\mu\text{A}$
$T_{amb} = -25\text{ °C to }+70\text{ °C}$	-	-	-	2	$\mu\text{A}$		
$V_{en}$	enable voltage	I <sup>2</sup> C-bus enable level	[5]	1.5	1.9	2.3	V
<b>Pin SDA</b>							
$V_{IL}$	LOW-level input voltage		[6]	-0.8	-	$0.3V_{DD}$	V
$V_{IH}$	HIGH-level input voltage		[6]	$0.7V_{DD}$	-	$V_{DD} + 0.8$	V
$I_{OL}$	LOW-level output current			3.0	-	-	mA
$I_{LI}$	input leakage current			-1	-	+1	$\mu\text{A}$
$C_I$	input capacitance		[7]	-	-	7	pF
<b>Pins A0 and OSCI</b>							
$I_{LI}$	input leakage current	$V_I = V_{DD}$ or $V_{SS}$		-250	-	+250	nA
<b>Pin INT</b>							
$I_{OL}$	LOW-level output current	$V_{OL} = 0.4\text{ V}$		3	-	-	mA
$I_{LI}$	input leakage current	$V_I = V_{DD}$ or $V_{SS}$		-1	-	+1	$\mu\text{A}$
<b>Pin SCL</b>							
$I_{LI}$	input leakage current	$V_I = V_{DD}$ or $V_{SS}$		-1	-	+1	$\mu\text{A}$
$C_I$	input capacitance		[7]	-	-	7	pF

[1] Typical values measured at  $T_{amb} = 25\text{ °C}$ .

[2] When the device is powered on,  $V_{DD}$  must exceed 1.5 V until the stable operation of the oscillator is established.

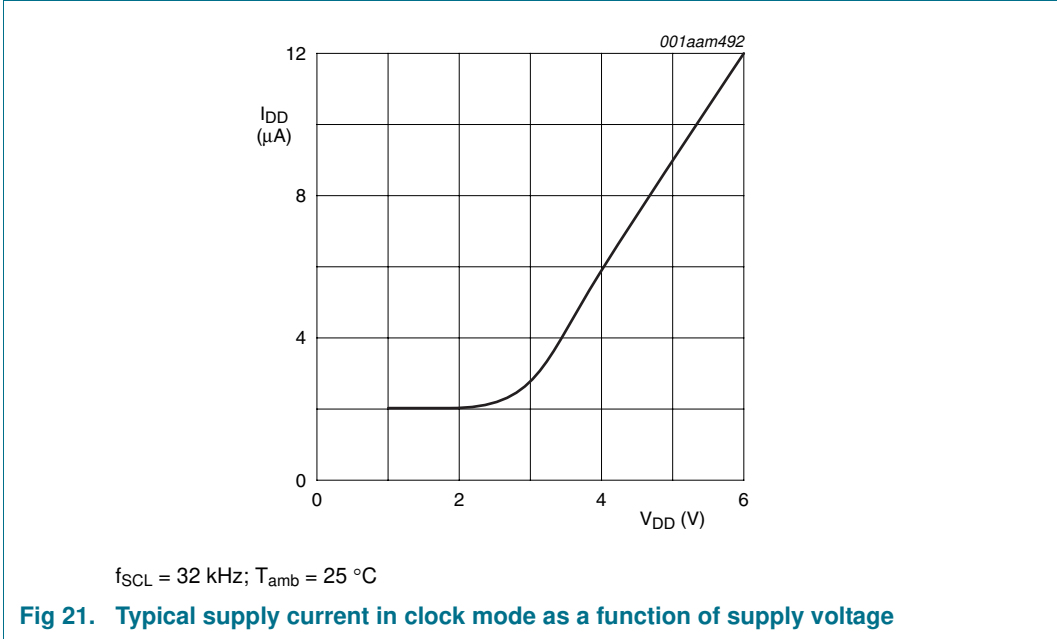
[3] Event counter mode: supply current dependant upon input frequency.

[4] See [Figure 21](#).

[5] The I<sup>2</sup>C-bus logic is disabled if  $V_{DD} < V_{en}$ .

[6] When the voltages are above or below the supply voltages  $V_{DD}$  or  $V_{SS}$ , an input current will flow; this current must not exceed  $\pm 0.5\text{ mA}$ .

[7] Tested on a sample basis.



## 10.2 Dynamic characteristics

**Table 8. Dynamic characteristics**

$V_{DD} = 2.5\text{ V to }6.0\text{ V}$ ;  $V_{SS} = 0\text{ V}$ ;  $T_{amb} = -40\text{ }^{\circ}\text{C to }+85\text{ }^{\circ}\text{C}$  unless otherwise specified.

Symbol	Parameter	Conditions	Min	Typ	Max	Unit
<b>Oscillator</b>						
$C_{OSCO}$	capacitance on pin OSCO		-	40	-	pF
$\Delta f_{osc}/f_{osc}$	relative oscillator frequency variation	for $\Delta V_{DD} = 100\text{ mV}$ ; $T_{amb} = 25\text{ }^{\circ}\text{C}$ ; $V_{DD} = 1.5\text{ V}$	-	0.2	-	ppm
$f_{clk(ext)}$	external clock frequency	on pin OSCI	[1]	-	1	MHz
<b>Quartz crystal parameters (f = 32.768 kHz)</b>						
$R_S$	series resistance		-	-	40	k $\Omega$
$C_L$	parallel load capacitance		-	10	-	pF
$C_{trim}$	trimmer capacitance		5	-	25	pF
<b>I<sup>2</sup>C-bus timing (see Figure 21)[2]</b>						
$f_{SCL}$	SCL clock frequency		-	-	100	kHz
$t_{SP}$	pulse width of spikes that must be suppressed by the input filter		-	-	100	ns
$t_{BUF}$	bus free time between a STOP and START condition		4.7	-	-	$\mu\text{s}$
$t_{SU,STA}$	set-up time for a repeated START condition		4.7	-	-	$\mu\text{s}$
$t_{HD,STA}$	hold time (repeated) START condition		4.0	-	-	$\mu\text{s}$
$t_{LOW}$	LOW period of the SCL clock		4.7	-	-	$\mu\text{s}$
$t_{HIGH}$	HIGH period of the SCL clock		4.0	-	-	$\mu\text{s}$
$t_r$	rise time of both SDA and SCL signals		-	-	1.0	$\mu\text{s}$
$t_f$	fall time of both SDA and SCL signals		-	-	0.3	$\mu\text{s}$
$t_{SU,DAT}$	data set-up time		250	-	-	ns
$t_{HD,DAT}$	data hold time		0	-	-	ns
$t_{VD,DAT}$	data valid time		-	-	3.4	$\mu\text{s}$
$t_{SU,STO}$	set-up time for STOP condition		4.0	-	-	$\mu\text{s}$

[1] Event counter mode only.

[2] All timing values are valid within the operating supply voltage, ambient temperature range, reference to  $V_{IL}$  and  $V_{IH}$  and with an input voltage swing of  $V_{SS}$  to  $V_{DD}$ .

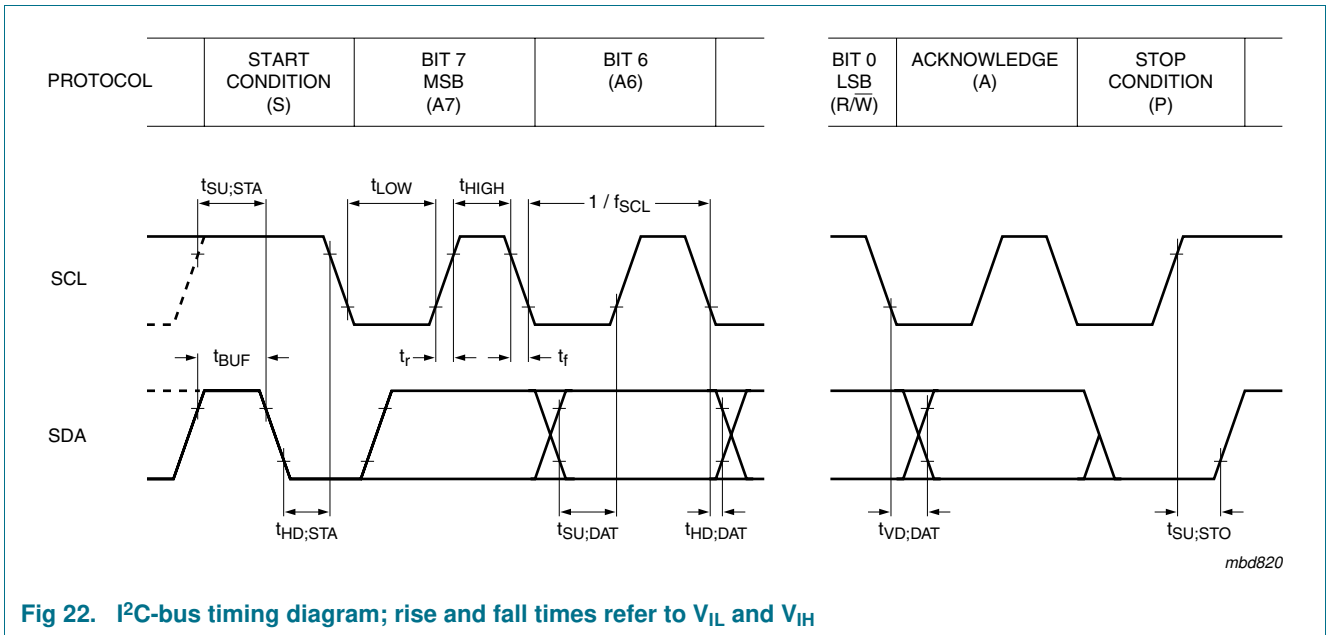


Fig 22. I<sup>2</sup>C-bus timing diagram; rise and fall times refer to V<sub>IL</sub> and V<sub>IH</sub>

## 11. Application information

---

### 11.1 Quartz frequency adjustment

#### 11.1.1 Method 1: Fixed OSCI capacitor

By evaluating the average capacitance necessary for the application layout, a fixed capacitor can be used. The frequency is measured using the 1 Hz signal available after power-on at the interrupt output (pin 7). The frequency tolerance depends on the quartz crystal tolerance, the capacitor tolerance and the device-to-device tolerance. Average deviations of  $\pm 5$  minutes per year are possible.

#### 11.1.2 Method 2: OSCI trimmer

Using the alarm function (via the I<sup>2</sup>C-bus) a signal faster than the 1 Hz is generated at the interrupt output for fast setting of a trimmer.

Procedure:

- Power the device on
- Initialize the device (alarm functions).

Routine:

- Set clock to time  $t$  and set alarm to time  $t + \Delta t$
- at time  $t + \Delta t$  (interrupt) repeat routine.

#### 11.1.3 Method 3: Direct measurement

Direct measurement of oscillator output (allowing for test probe capacitance).

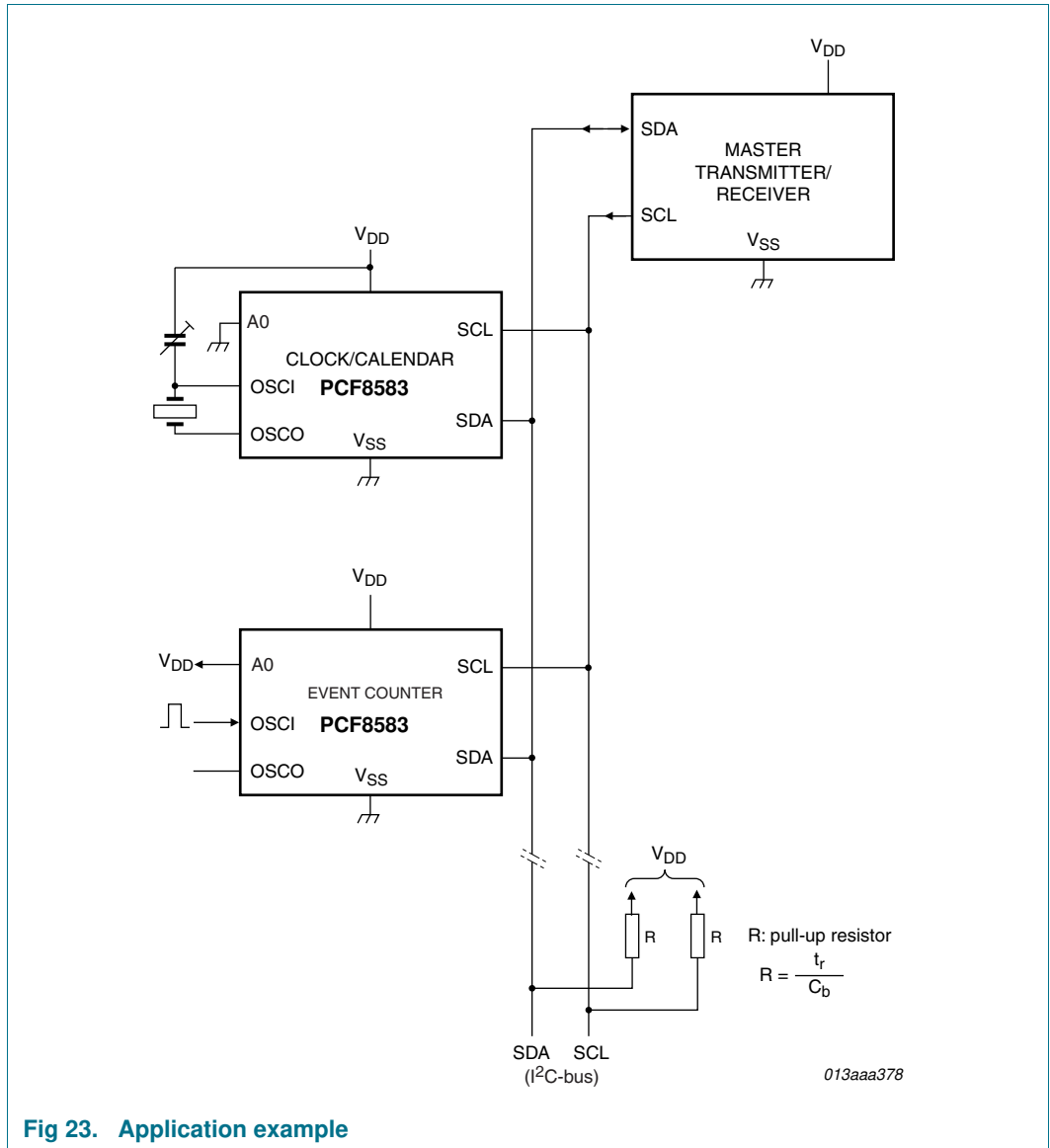


Fig 23. Application example