



Chipsmall Limited consists of a professional team with an average of over 10 year of expertise in the distribution of electronic components. Based in Hongkong, we have already established firm and mutual-benefit business relationships with customers from,Europe,America and south Asia,supplying obsolete and hard-to-find components to meet their specific needs.

With the principle of “Quality Parts,Customers Priority,Honest Operation,and Considerate Service”,our business mainly focus on the distribution of electronic components. Line cards we deal with include Microchip,ALPS,ROHM,Xilinx,Pulse,ON,Everlight and Freescale. Main products comprise IC,Modules,Potentiometer,IC Socket,Relay,Connector.Our parts cover such applications as commercial,industrial, and automotives areas.

We are looking forward to setting up business relationship with you and hope to provide you with the best service and solution. Let us make a better world for our industry!



Contact us

Tel: +86-755-8981 8866 Fax: +86-755-8427 6832

Email & Skype: info@chipsmall.com Web: www.chipsmall.com

Address: A1208, Overseas Decoration Building, #122 Zhenhua RD., Futian, Shenzhen, China



DATA SHEET

PCK2002P

533 MHz PCI-X clock buffer

Product data
Supersedes data of 2001 May 09

2002 Dec 13

533 MHz PCI-X clock buffer

PCK2002P

FEATURES

- General purpose and PCI-X 1:4 clock buffer
- 8-pin TSSOP package
- See PCK2001 for 48-pin 1:18 buffer part
- See PCK2001M for 28-pin 1:10 buffer part
- See PCK2001R for 16-pin 1:6 buffer part
- Operating frequency: 0 - 533 MHz
- Part-to-part skew < 500 ps
- Low output skew: <200 ps
- 3.3 V operation
- ESD classification testing is done to JEDEC Standard JESD22. Protection exceeds 2000 V to HBM per method A114.

DESCRIPTION

The PCK2002PL is a 1-4 fanout buffer used as a high-performance, low skew, general purpose and PCI-X clock buffer. It distributes one input clock (BUF_IN) signal to four output clocks (BUF_OUT_n).

PIN CONFIGURATION

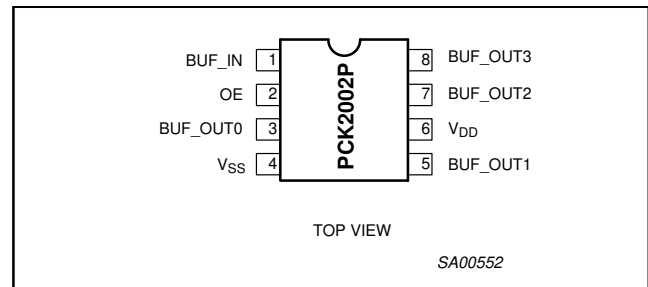

PIN DESCRIPTION

PIN NUMBER	I/O TYPE	SYMBOL	FUNCTION
1	Input	BUF_IN	Buffered clock input
3, 5, 7, 8	Output	BUF_OUT (0-3)	Buffered clock outputs
6	Input	V _{DD}	3.3 V supply
2	Input	OE	Output Enable
4	Input	V _{SS}	Ground

QUICK REFERENCE DATA

SYMBOL	PARAMETER	CONDITIONS	TYPICAL	UNIT
t _{PLH} t _{PHL}	Propagation delay BUF_IN to BUF_OUT _n	V _{CC} = 3.3 V, C _L = 25 pF	2.9 2.8	ns
t _r	Rise time	V _{CC} = 3.3 V, C _L = 25 pF, 0.2V _{DD} to 0.6V _{DD}	800	ps
t _f	Fall time	V _{CC} = 3.3 V, C _L = 25 pF, 0.6V _{DD} to 0.2V _{DD}	600	ps
I _{CC}	Total supply current	V _{CC} = 3.6 V	50	μA

ORDERING INFORMATION

PACKAGES	TEMPERATURE RANGE	ORDER CODE	DRAWING NUMBER
8-Pin Plastic TSSOP	-40 to +85 °C	PCK2002PDP	SOT505-1
8-Pin Plastic SO	-40 to +85 °C	PCK2002PD	SOT96-1

533 MHz PCI-X clock buffer

PCK2002P

FUNCTION TABLE

OE	BUF_IN	BUF_OUTn
L	X	L
H	L	L
H	H	H

ABSOLUTE MAXIMUM RATINGS^{1, 2}

In accordance with the Absolute Maximum Rating System (IEC 134).

Voltages are referenced to V_{SS} ($V_{SS} = 0$ V).

SYMBOL	PARAMETER	CONDITION	LIMITS		UNIT
			MIN	MAX	
V_{DD}	DC 3.3 V supply voltage		-0.5	+4.3	V
I_{IK}	DC input diode current	$V_I < 0$	—	-50	mA
V_I	DC input voltage	Note 2	-0.5	$V_{DD} + 0.5$	V
I_{OK}	DC output diode current	$V_O > V_{DD}$ or $V_O < 0$	—	± 50	mA
V_O	DC output voltage	Note 2	-0.5	$V_{DD} + 0.5$	V
I_O	DC output source or sink current	$V_O \geq 0$ to V_{DD}	—	± 50	mA
T_{stg}	Storage temperature range		-65	+150	°C
P_{tot}	Power dissipation per package plastic medium-shrink SO (SSOP)	For temperature range: 0 to +70 °C above +55 °C derate linearly with 11.3 mW/K	—	850	mW

NOTES:

- Stresses beyond those listed may cause permanent damage to the device. These are stress ratings only and functional operation of the device at these or any other conditions beyond those indicated under "recommended operating conditions" is not implied. Exposure to absolute-maximum-rated conditions for extended periods may affect device reliability.
- The input and output voltage ratings may be exceeded if the input and output current ratings are observed.

RECOMMENDED OPERATING CONDITIONS

SYMBOL	PARAMETER	CONDITIONS	LIMITS		UNIT
			MIN	MAX	
V_{DD}	DC 3.3V supply voltage		3.0	3.6	V
C_L	Capacitive load		20	30	pF
V_I	DC input voltage range		0	V_{DD}	V
V_O	DC output voltage range		0	V_{DD}	V
T_{amb}	Operating ambient temperature range in free air		-40	+85	°C

533 MHz PCI-X clock buffer

PCK2002P

DC CHARACTERISTICS

SYMBOL	PARAMETER	TEST CONDITIONS			LIMITS		UNIT
					$T_{amb} = -40 \text{ to } +85 \text{ } ^\circ\text{C}$		
		V_{DD} (V)	OTHER		MIN	MAX	
V_{IH}	HIGH level input voltage	3.0 to 3.6	—	—	2.0	$V_{DD} + 0.3$	V
V_{IL}	LOW level input voltage	3.0 to 3.6	—	—	$V_{SS} - 0.3$	0.8	V
V_{OH}	Output HIGH voltage	3.0 to 3.6	$I_{OH} = -1 \text{ mA}$	—	$V_{DD} - 0.2$	—	V
		3.0	$I_{OH} = -24 \text{ mA}$	—	2.0	—	V
		3.0	$I_{OH} = -12 \text{ mA}$	—	2.4	—	V
V_{OL}	Output LOW voltage	3.0 to 3.6	$I_{OL} = 1 \text{ mA}$	—	—	0.2	V
		3.0	$I_{OL} = 24 \text{ mA}$	—	—	0.8	V
		3.0	$I_{OL} = 12 \text{ mA}$	—	—	0.55	V
I_{OH}	Output HIGH current	3.0	$V_{OUT} = 1 \text{ V}$	—	-50	—	mA
		3.3	$V_{OUT} = 1.65 \text{ V}$	—	—	-150	mA
I_{OL}	Output LOW current	3.0	$V_{OUT} = 2.0 \text{ V}$	—	60	—	mA
		3.3	$V_{OUT} = 1.65 \text{ V}$	—	—	150	mA
$\pm I_I$	Input leakage current	3.6	$V_I = V_{DD}$ or GND	—	—	± 5	μA
I_{CC}	Quiescent supply current	3.6	$V_I = V_{DD}$ or GND	$I_O = 0$	—	100	μA

533 MHz PCI-X clock buffer

PCK2002P

AC CHARACTERISTICS

SYMBOL	PARAMETER	TEST CONDITIONS	NOTES	LIMITS $T_{amb} = -40 \text{ to } +85 \text{ } ^\circ\text{C}$			UNIT
				MIN	TYP ⁶	MAX	
t_H	CLK HIGH time	66 MHz	2	6.0	—	—	ns
t_L	CLK LOW time		3	6.0	—	—	ns
t_H	CLK HIGH time	140 MHz	2	2.9	—	—	ns
t_L	CLK LOW time		3	3.0	—	—	ns
t_R	Output rise slew rate		4	1.4	1.7	4.0	V/ns
t_F	Output fall slew rate		4	1.5	2.2	4.0	V/ns
t_{PLH}	Buffer LH propagation delay		5	1.8	2.9	3.4	ns
t_{PHL}	Buffer HL propagation delay		5	1.8	2.8	3.4	ns
t_{SKW}	Bus CLK skew		1	—	—	200	ps
t_{DDSKW}	Device to device skew		1	—	—	500	ps

NOTES:

1. CLK skew is only valid for equal loading of all outputs.
2. t_H is measured at 0.5 V_{DD} as shown in Figure 2.
3. t_L is measured at 0.35 V_{DD} as shown in Figure 2.
4. t_R and t_F are measured as a transition through the threshold region 0.2 V_{DD} to 0.6 V_{DD} and 0.6 V_{DD} to 0.2 V_{DD} .
5. Input edge rate for these tests must be faster than 1 V/ns.
6. All typical values are at $V_{CC} = 3.3 \text{ V}$ and $T_{amb} = 25 \text{ } ^\circ\text{C}$.

AC WAVEFORMS

$V_M = 50\% V_{DD}$
 $C_L = 25 \text{ pF}$
 V_{OL} and V_{OH} are the typical output voltage drop that occur with the output load.

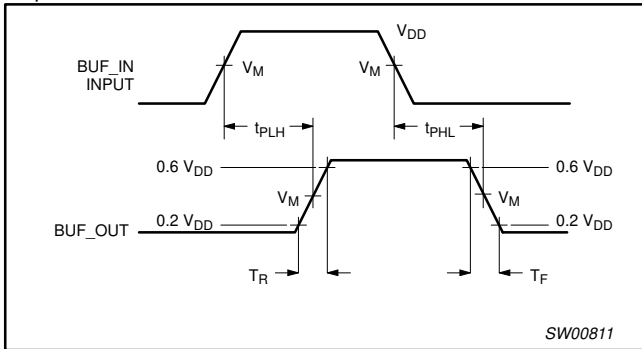

Figure 1. Load circuitry for switching times.

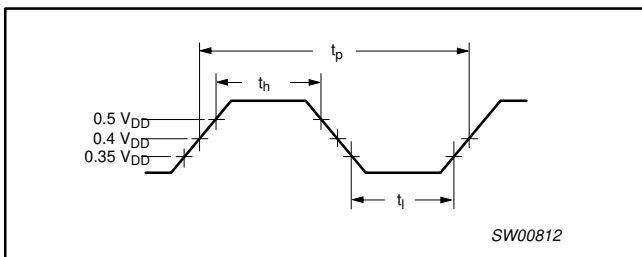

Figure 2. Buffer Output clock

TEST CIRCUIT

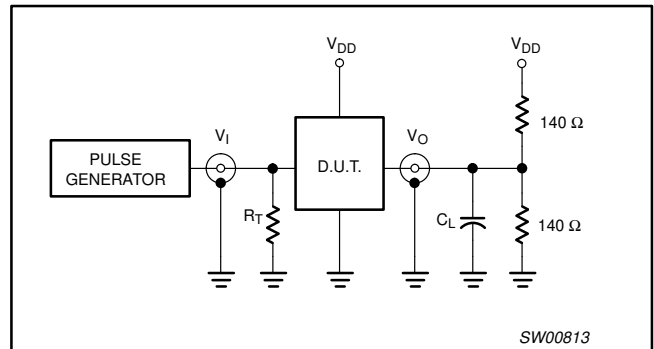

Figure 3. Load circuitry for switching times

533 MHz PCI-X clock buffer

PCK2002P

TSSOP8: plastic thin shrink small outline package; 8 leads; body width 3 mm

SOT505-1

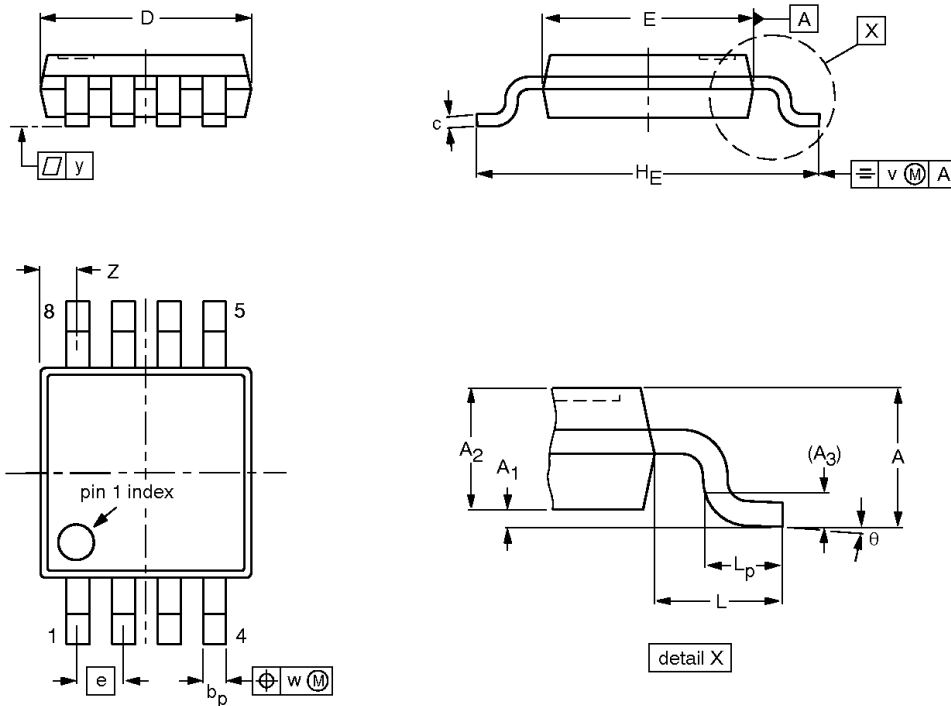

DIMENSIONS (mm are the original dimensions)

UNIT	A _{max.}	A ₁	A ₂	A ₃	b _p	c	D ⁽¹⁾	E ⁽²⁾	e	H _E	L	L _p	v	w	y	Z ⁽¹⁾	θ
mm	1.10	0.15 0.05	0.95 0.80	0.25	0.45 0.25	0.28 0.15	3.10 2.90	3.10 2.90	0.65	5.10 4.70	0.94	0.70 0.40	0.1	0.1	0.1	0.70 0.35	6° 0°

Notes

1. Plastic or metal protrusions of 0.15 mm maximum per side are not included.
2. Plastic or metal protrusions of 0.25 mm maximum per side are not included.

OUTLINE VERSION	REFERENCES				EUROPEAN PROJECTION	ISSUE DATE
	IEC	JEDEC	EIAJ			
SOT505-1						99-04-09

533 MHz PCI-X clock buffer

PCK2002P

SO8: plastic small outline package; 8 leads; body width 3.9 mm

SOT96-1

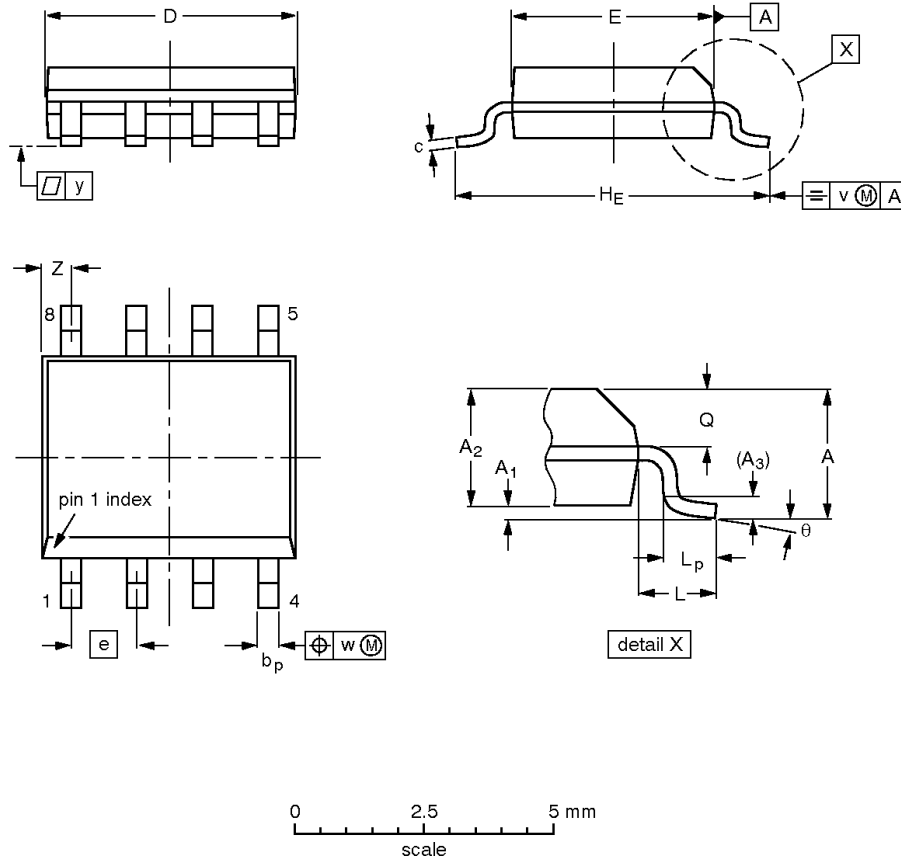

DIMENSIONS (inch dimensions are derived from the original mm dimensions)

UNIT	A max.	A ₁	A ₂	A ₃	b _p	c	D ⁽¹⁾	E ⁽²⁾	e	H _E	L	L _p	Q	v	w	y	Z ⁽¹⁾	θ
mm	1.75	0.25 0.10	1.45 1.25	0.25	0.49 0.36	0.25 0.19	5.0 4.8	4.0 3.8	1.27	6.2 5.8	1.05	1.0 0.4	0.7 0.6	0.25	0.25	0.1	0.7 0.3	8° 0°
inches	0.069	0.010 0.004	0.057 0.049	0.01	0.019 0.014	0.0100 0.0075	0.20 0.19	0.16 0.15	0.050	0.244 0.228	0.041	0.039 0.016	0.028 0.024	0.01	0.01	0.004	0.028 0.012	

Notes

1. Plastic or metal protrusions of 0.15 mm maximum per side are not included.
2. Plastic or metal protrusions of 0.25 mm maximum per side are not included.

OUTLINE VERSION	REFERENCES				EUROPEAN PROJECTION	ISSUE DATE
	IEC	JEDEC	EIAJ			
SOT96-1	076E03	MS-012				97-05-22 99-12-27

533 MHz PCI-X clock buffer

PCK2002P

REVISION HISTORY

Rev	Date	Description
3	20021213	Product data (9397 750 10863); ECN 853-2254 29225 of 22 November 2002 Modifications: <ul style="list-style-type: none">• Increase F{\max} to 533 MHz.
_2	20010509	Product data (9397 750 08348); ECN 853-2254 26252 of 09 May 2001.

533 MHz PCI-X clock buffer

PCK2002P

Data sheet status

Level	Data sheet status ^[1]	Product status ^[2] [3]	Definitions
I	Objective data	Development	This data sheet contains data from the objective specification for product development. Philips Semiconductors reserves the right to change the specification in any manner without notice.
II	Preliminary data	Qualification	This data sheet contains data from the preliminary specification. Supplementary data will be published at a later date. Philips Semiconductors reserves the right to change the specification without notice, in order to improve the design and supply the best possible product.
III	Product data	Production	This data sheet contains data from the product specification. Philips Semiconductors reserves the right to make changes at any time in order to improve the design, manufacturing and supply. Relevant changes will be communicated via a Customer Product/Process Change Notification (CPCN).

[1] Please consult the most recently issued data sheet before initiating or completing a design.

[2] The product status of the device(s) described in this data sheet may have changed since this data sheet was published. The latest information is available on the Internet at URL <http://www.semiconductors.philips.com>.

[3] For data sheets describing multiple type numbers, the highest-level product status determines the data sheet status.

Definitions

Short-form specification — The data in a short-form specification is extracted from a full data sheet with the same type number and title. For detailed information see the relevant data sheet or data handbook.

Limiting values definition — Limiting values given are in accordance with the Absolute Maximum Rating System (IEC 60134). Stress above one or more of the limiting values may cause permanent damage to the device. These are stress ratings only and operation of the device at these or at any other conditions above those given in the Characteristics sections of the specification is not implied. Exposure to limiting values for extended periods may affect device reliability.

Application information — Applications that are described herein for any of these products are for illustrative purposes only. Philips Semiconductors make no representation or warranty that such applications will be suitable for the specified use without further testing or modification.

Disclaimers

Life support — These products are not designed for use in life support appliances, devices, or systems where malfunction of these products can reasonably be expected to result in personal injury. Philips Semiconductors customers using or selling these products for use in such applications do so at their own risk and agree to fully indemnify Philips Semiconductors for any damages resulting from such application.

Right to make changes — Philips Semiconductors reserves the right to make changes in the products—including circuits, standard cells, and/or software—described or contained herein in order to improve design and/or performance. When the product is in full production (status 'Production'), relevant changes will be communicated via a Customer Product/Process Change Notification (CPCN). Philips Semiconductors assumes no responsibility or liability for the use of any of these products, conveys no license or title under any patent, copyright, or mask work right to these products, and makes no representations or warranties that these products are free from patent, copyright, or mask work right infringement, unless otherwise specified.

Contact information

For additional information please visit
<http://www.semiconductors.philips.com>. Fax: +31 40 27 24825

© Koninklijke Philips Electronics N.V. 2002
 All rights reserved. Printed in U.S.A.

Date of release: 12-02

For sales offices addresses send e-mail to:
sales.addresses@www.semiconductors.philips.com.

Document order number:

9397 750 10863

Let's make things better.