



Chipsmall Limited consists of a professional team with an average of over 10 year of expertise in the distribution of electronic components. Based in Hongkong, we have already established firm and mutual-benefit business relationships with customers from,Europe,America and south Asia,supplying obsolete and hard-to-find components to meet their specific needs.

With the principle of "Quality Parts,Customers Priority,Honest Operation,and Considerate Service",our business mainly focus on the distribution of electronic components. Line cards we deal with include Microchip,ALPS,ROHM,Xilinx,Pulse,ON,Everlight and Freescale. Main products comprise IC,Modules,Potentiometer,IC Socket,Relay,Connector.Our parts cover such applications as commercial,industrial, and automotives areas.

We are looking forward to setting up business relationship with you and hope to provide you with the best service and solution. Let us make a better world for our industry!



Contact us

Tel: +86-755-8981 8866 Fax: +86-755-8427 6832

Email & Skype: info@chipsmall.com Web: www.chipsmall.com

Address: A1208, Overseas Decoration Building, #122 Zhenhua RD., Futian, Shenzhen, China



DATA SHEET

PCK857

50-150MHz differential 1:10 SDRAM
clock driver

Product data
Supersedes data of 2000 Jun 15

2003 Jul 31

50-150 MHz differential 1:10 SDRAM clock driver

PCK857

FEATURES

- Optimized for clock distribution in DDR (Double Data Rate) SDRAM applications
- 1-to-10 differential clock distribution
- Very low skew (< 100 ps) and jitter (< 100 ps)
- 3 V AV_{CC} and 2.5 V V_{CC}
- SSTL_2 interface clock inputs and outputs
- CMOS control signal input
- Test mode enables buffers while disabling PLL
- Low current power-down mode
- Tolerant of Spread Spectrum input clock
- Full DDR solution provided when used with SSTL16857 and CBT3857

DESCRIPTION

Zero delay buffer to distribute an SSTL differential clock input pair to 10 SSTL_2 differential output pairs. Outputs are slope controlled. External feedback pin for synchronization of the outputs to the input. A CMOS style Enable/Disable pin is provided for low power disable.

PIN CONFIGURATION

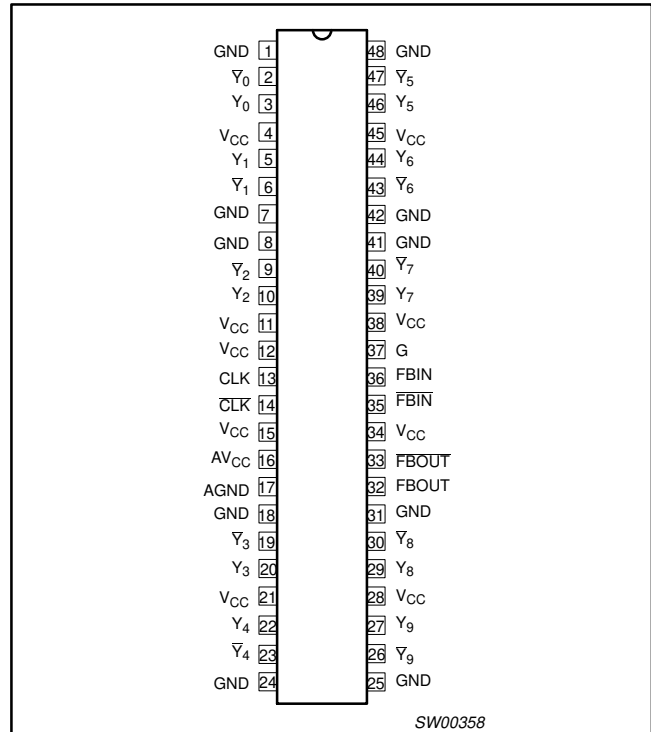

ORDERING INFORMATION

PACKAGES	TEMPERATURE RANGE	ORDER CODE	DRAWING NUMBER
48-Pin Plastic TSSOP	0 to +85 °C	PCK857DGG	SOT362-1

50-150 MHz differential 1:10 SDRAM clock driver

PCK857

PIN DESCRIPTION

PINS	SYMBOL	I/O	DESCRIPTION
17	AGND	Ground	Analog ground. AGND provides the ground reference for the analog circuitry.
16	AV _{CC}	Power	Analog power supply. AV _{CC} provides the power reference for the analog circuitry. In addition, AV _{CC} can be used to bypass the PLL for test purposes. When AV _{CC} is strapped to ground, PLL is bypassed and CLK is buffered directly to the device outputs. During disable (G = 0), the PLL is powered down.
13, 14	CLK, $\overline{\text{CLK}}$	I	Clock input. CLK provides the clock signal to be distributed by the PCK857 clock driver. CLK is used to provide the reference signal to the integrated PLL that generates the clock output signals. CLK must have a fixed frequency and fixed phase for the PLL to obtain phase lock. Once the circuit is powered up and a valid CLK is applied, a stabilization time is required for the PLL to phase lock the feedback signal to its reference signal.
36, 35	FB _{IN} , $\overline{\text{FB}}_{\text{IN}}$	I	Feedback input. FB _{IN} provides the feedback signal to the internal PLL. FB _{IN} must be hard-wired to FB _{OUT} to complete the PLL. The integrated PLL synchronizes CLK and FB _{IN} so that there is nominally zero phase error between CLK and FB _{IN} .
32, 33	FB _{OUT} , $\overline{\text{FB}}_{\text{OUT}}$	O	Feedback output. FB _{OUT} is dedicated for external feedback. It switches at the same frequency as CLK. When externally wired to FB _{IN} , FB _{OUT} completes the feedback loop of the PLL.
37	G	I	Output bank enable. G is the output enable for outputs Y and \overline{Y} . When G is low outputs Y are disabled to a high-impedance state. When G is high, all outputs Y are enabled and switch at the same frequency as CLK.
1, 7, 8, 18, 24, 25, 31, 41, 42, 48	GND	Ground	Ground
4, 11, 12, 15, 21, 28, 34, 38, 45	V _{CC}	Power	Power supply
3, 5, 10, 20, 22, 46, 44, 39, 29, 27	Y ₀ , Y ₁ , Y ₂ , Y ₃ , Y ₄ , Y ₅ , Y ₆ , Y ₇ , Y ₈ , Y ₉	O	Clock outputs. These outputs provide low-skew copies of CLK.
2, 6, 9, 19, 23, 47, 43, 40, 30, 26	\overline{Y}_0 , \overline{Y}_1 , \overline{Y}_2 , \overline{Y}_3 , \overline{Y}_4 , \overline{Y}_5 , \overline{Y}_6 , \overline{Y}_7 , \overline{Y}_8 , \overline{Y}_9	O	Clock outputs. These outputs provide low-skew copies of $\overline{\text{CLK}}$.

FUNCTION TABLE

INPUTS			OUTPUTS				PLL ON/OFF
G	CLK	$\overline{\text{CLK}}$	Y	\overline{Y}	F _{BOUT}	$\overline{\text{F}}_{\text{BOUT}}$	
L	L	H	Z	Z	Z ¹	Z ¹	OFF
L	H	L	Z	Z	Z ¹	Z ¹	OFF
H	L	H	L	H	L	H	ON
H	H	L	H	L	H	L	ON
X ²	< 20 MHz	< 20 MHz	Z	Z	Z ¹	Z ¹	OFF

NOTES:

H = HIGH voltage level

L = LOW voltage level

Z = HIGH impedance OFF-state

X = don't care

1. Subject to change. May cause conflict with FB_{IN} pins.

2. Additional feature that senses when the clock input is less than 20 MHz and places the part in sleep mode.

50-150 MHz differential 1:10 SDRAM clock driver

PCK857

BLOCK DIAGRAM

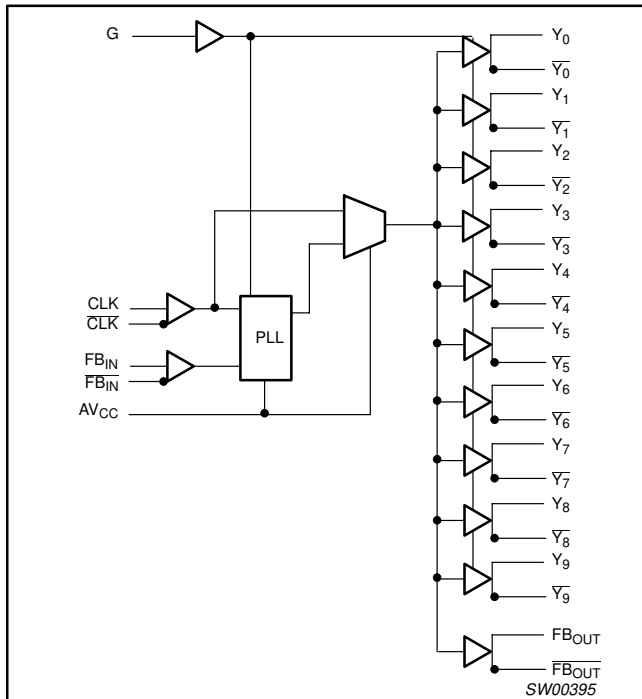

DC ELECTRICAL CHARACTERISTICS

Over recommended operating conditions. Voltages are referenced to GND (ground = 0 V).

SYMBOL	PARAMETER		TEST CONDITIONS	LIMITS			UNIT
				MIN	TYP	MAX	
V _{IK}	Input voltage	All input pins	V _{CC} = 2.3 V; I _I = -18 mA			-1.2	V
V _{OH}	HIGH-level output voltage		V _{CC} = min to max; I _{OH} = -1 mA	V _{CC} - 0.1			V
			V _{CC} = 2.3 V; I _{OH} = -12 mA	1.7			
V _{OL}	LOW-level output voltage		V _{CC} = min to max; I _{OL} = 1 mA			0.1	V
			V _{CC} = 2.3 V; I _{OL} = 12 mA			0.6	
I _{OH}	HIGH-level output current		V _{CC} = 2.3 V; V _O = 1 V	-18	-32		mA
I _{OL}	LOW-level output current		V _{CC} = 2.3 V; V _O = 1.2 V	26	35		mA
I _I	Input current		G	V _{CC} = 2.7 V; V _I = 0 V to 2.7 V			μA
			CLK, FB _{IN}	V _{CC} = 2.7 V; V _I = 0 V to 2.7 V			
I _{OZ}	HIGH-impedance output current		V _{CC} = 2.7 V; V _O = V _{CC} or GND			±10	μA
V _{OC}	Output crossing point voltage			(V _{CC} /2) - 0.1	V _{CC} /2	(V _{CC} /2) + 0.1	V
I _{CCZ}	Supply current, disabled		AV _{CC} and V _{CC} = max, G = L or no input CLK signal		500	800	μA
I _{CC}	Supply current on AV _{CC}		V _{CC} = 2.7 V, All outputs switching environment; f _O = 167 MHz, 16 pF in 60 Ω See Figure 3		235	330	mA
AI _{CC}	Supply current on AV _{CC}		AV _{CC} = 3.6 V; f _O = 167 MHz		9	12	mA
C _I	Input capacitance		V _{CC} = 2.5 V; V _I = V _{CC} or GND		2		pF
C _O	Output capacitance		V _{CC} = 2.5 V; V _O = V _{CC} or GND		3		pF

50-150 MHz differential 1:10 SDRAM clock driver

PCK857

ABSOLUTE MAXIMUM RATINGS^{1,2}

SYMBOL	PARAMETER	CONDITION	LIMITS		UNIT
			MIN	MAX	
V_{CC}/AV_{CC}	Supply voltage range		-0.5	4.6	V
V_I	Input voltage	Note 2	-0.5	$V_{DDQ} + 0.5$	V
V_O	Output voltage	Note 2	-0.5	$V_{DDQ} + 0.5$	V
I_{IK}	Input diode current	$V_I < 0$ or $V_I > V_{CC}$		± 50	mA
I_{OK}	Output diode current	$V_O < 0$ or $V_O > V_{CC}$		± 50	mA
I_O	Output source or sink current	$V_O = 0$ to V_{CC}		± 50	mA
T_{stg}	Storage temperature range		-65	+150	°C
θ_{JA}	Package thermal impedance	Note 3		89	°C/W

NOTES:

- Stresses beyond those listed may cause permanent damage to the device. These are stress ratings only and functional operation of the device at these or any other conditions beyond those indicated under "recommended operating conditions" is not implied. Exposure to absolute-maximum-rated conditions for extended periods may affect device reliability.
- The input and output voltage ratings may be exceeded if the input and output current ratings are observed.
- The package thermal impedance is calculated in accordance with JESD51.

RECOMMENDED OPERATING CONDITIONS

SYMBOL	PARAMETER	CONDITIONS	LIMITS			UNIT
			MIN	TYP	MAX	
V_{CC}	Supply voltage		2.3	2.5	2.7	V
AV_{CC}	Analog supply voltage		3.0	3.3	3.6	V
V_{IL}	G input				$0.3 X V_{CC}$	V
V_{IH}	G input		$0.7 X V_{CC}$			V
V_I	CLK, FB_{IN}		-0.3		$V_{CC} + 0.3$	V
I_{OH}	HIGH-level output current				-12	mA
I_{OL}	LOW-level output current				12	mA

timing requirements over recommended ranges or supply voltage and operating free-air temperature

PARAMETER	CONDITIONS	MIN	MAX	UNIT
f_C Clock frequency		66	167	MHz
Input clock duty cycle		40%	60%	
Stabilization time ¹			100	μ S

NOTE:

- Time required for the integrated PLL circuit to obtain phase lock of its feedback signal to its reference signal. For phase lock to be obtained, a fixed-frequency, fixed-phase reference signal must be present at CLK. Until phase lock is obtained, the specifications for propagation delay, skew, and jitter parameters given in the switching characteristics are not applicable. This parameter does not apply for input modulation under SSC application.

50-150 MHz differential 1:10 SDRAM clock driver

PCK857

AC CHARACTERISTICS

GND = 0 V; $t_r = t_f \leq 2.5$ ns; $C_L = 50$ pF; $R_L = 1$ k Ω

SYMBOL	PARAMETER	WAVEFORM	CONDITION	LIMITS			UNIT
				MIN	TYP	MAX	
t_{PLH}^1	Low to high propagation	Figure 4	CLK to any output	1.5	3.5	6	ns
t_{PHL}^1	High to low propagation	Figure 4	CLK to any output	1.5	3.5	6	ns
$f_{PHASERROR}$	Phase error			-150	0	150	ps
f_{SK}	Output clock skew	Figure 1				100	ps
f_{difSK}	Differential clock skew					100	ps
f_{SL}	Output clock skew rate			1	1.5		V/ns
Jitter _{pp}	Peak-to-Peak jitter (long term)			-100		100	ps
Jitter _{cc}	Cycle-to-cycle jitter (short term)	Figure 3		> -100		< 100	ps
f_{DC}	Duty cycle	Figure 2		45		55	%
C_{in}	Input capacitance			2.5		4	pF
t_r, t_f	Output rise and fall times		20%-80%	650	800	950	ps

NOTE:

1. Refers to transition of reinverting output.

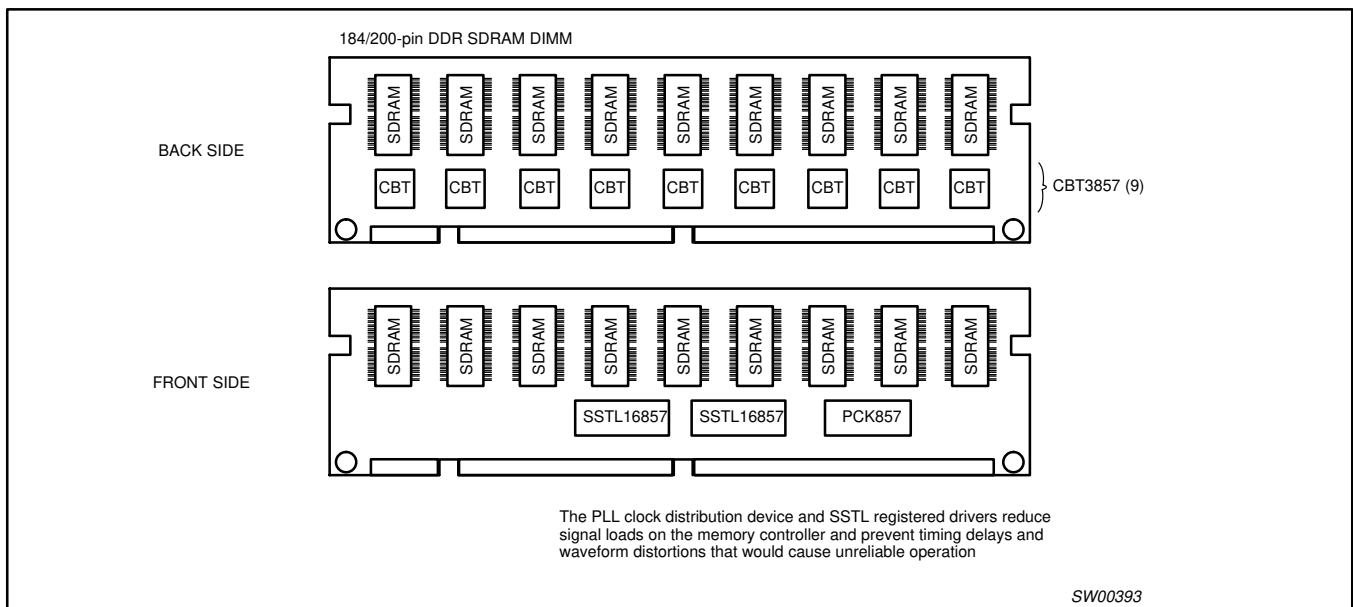

50-150 MHz differential 1:10 SDRAM clock driver

PCK857

AC WAVEFORMS

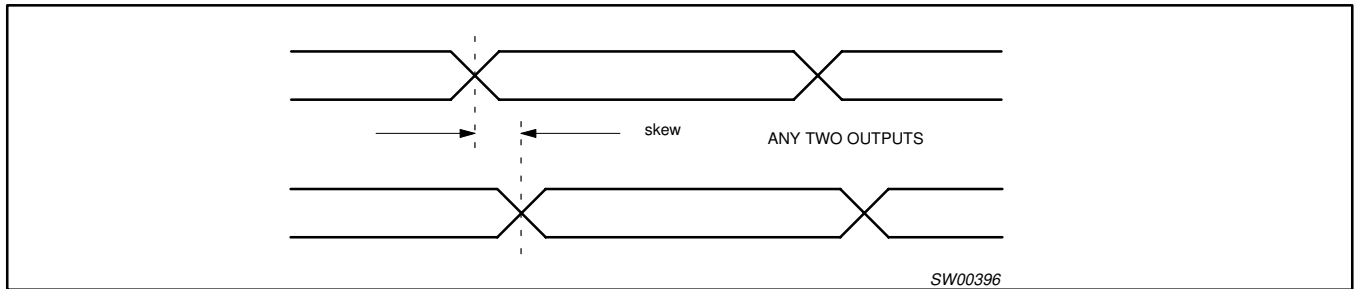

Figure 1. Skew between any two outputs.

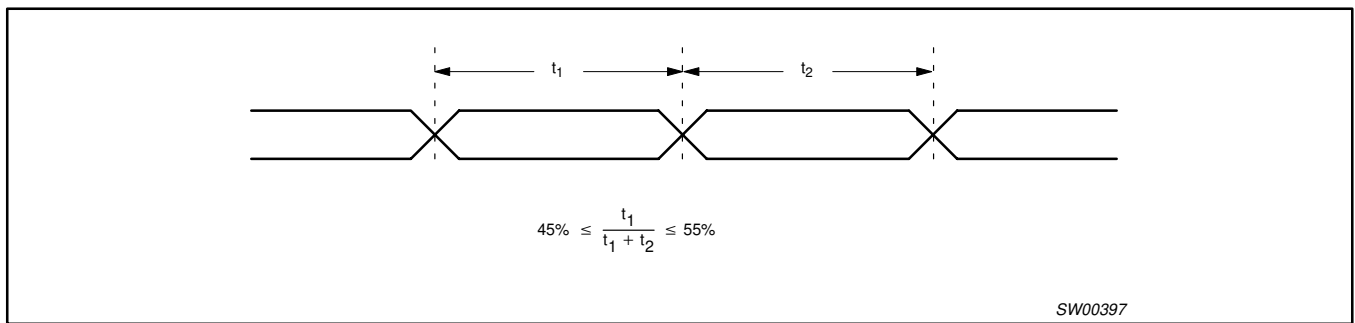

Figure 2. Duty cycle limits and measurement

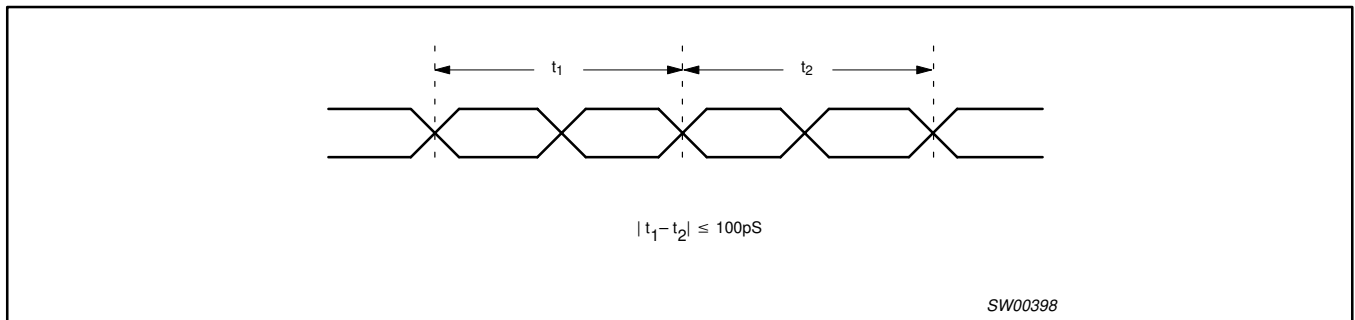

Figure 3. Jitter limit and measurement

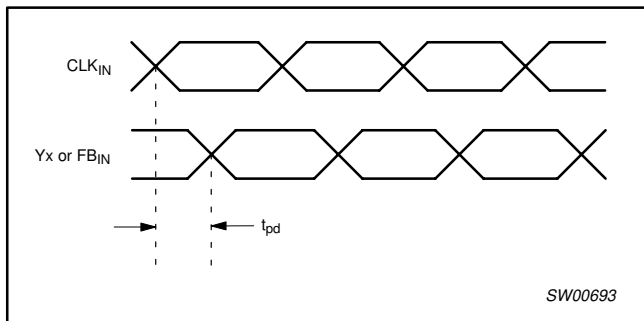
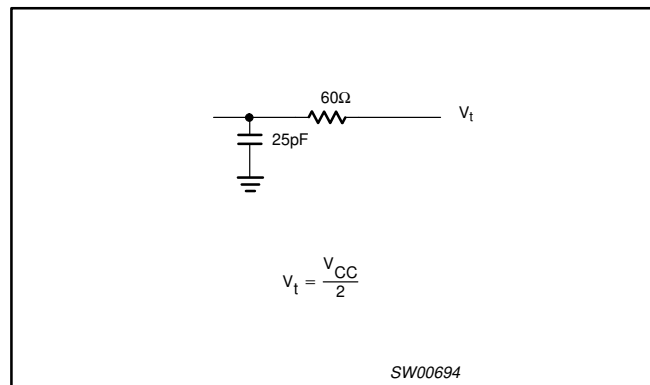

Figure 4. Propagation delay time; t_{PLH} , t_{PHL}

TEST CIRCUIT



50-150 MHz differential 1:10 SDRAM clock driver

PCK857

TSSOP48: plastic thin shrink small outline package; 48 leads; body width 6.1 mm

SOT362-1

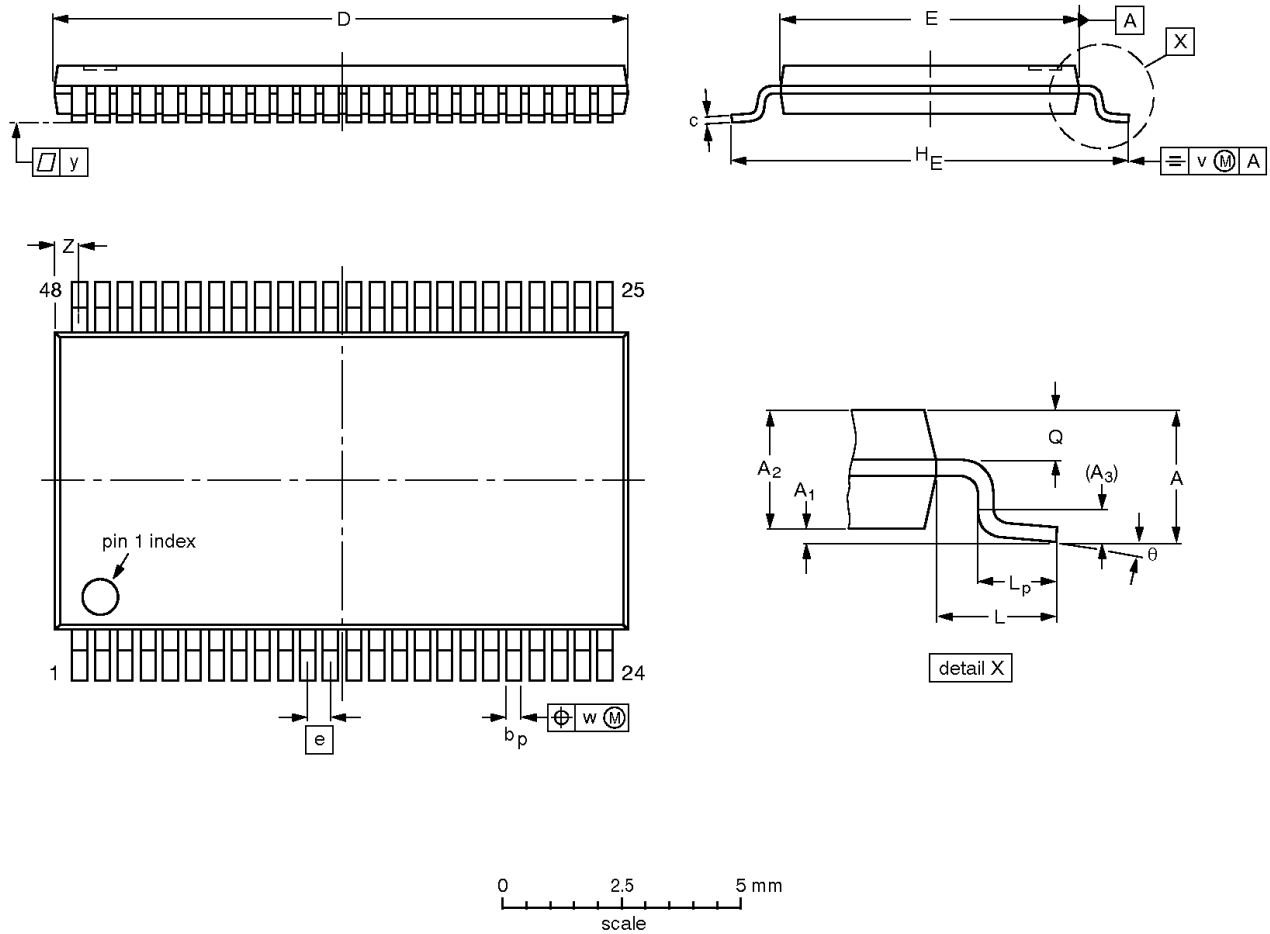

DIMENSIONS (mm are the original dimensions).

UNIT	A max.	A ₁	A ₂	A ₃	b _p	c	D ⁽¹⁾	E ⁽²⁾	e	H _E	L	L _p	Q	v	w	y	Z	θ
mm	1.2	0.15 0.05	1.05 0.85	0.25	0.28 0.17	0.2 0.1	12.6 12.4	6.2 6.0	0.5	8.3 7.9	1	0.8 0.4	0.50 0.35	0.25	0.08	0.1	0.8 0.4	8° 0°

Notes

1. Plastic or metal protrusions of 0.15 mm maximum per side are not included.
2. Plastic interlead protrusions of 0.25 mm maximum per side are not included.

OUTLINE VERSION	REFERENCES				EUROPEAN PROJECTION	ISSUE DATE
	IEC	JEDEC	EIAJ			
SOT362-1		MO-153				-95-02-10 99-12-27

50-150 MHz differential 1:10 SDRAM clock driver

PCK857

REVISION HISTORY

Rev	Date	Description
_3	20030731	Product data (9397 750 11764); ECN 853-2199 30051 of 18 June 2003; supersedes data of 2000 June 15 (9397 750 07193). Modifications: <ul style="list-style-type: none">• Corrections and minor changes to existing product specifications.
_2	20000715	Product data (9397 750 07193); ECN 853-2199 23880 of 2000 June 15.

50-150 MHz differential 1:10 SDRAM clock driver

PCK857

Data sheet status

Level	Data sheet status ^[1]	Product status ^[2] [3]	Definitions
I	Objective data	Development	This data sheet contains data from the objective specification for product development. Philips Semiconductors reserves the right to change the specification in any manner without notice.
II	Preliminary data	Qualification	This data sheet contains data from the preliminary specification. Supplementary data will be published at a later date. Philips Semiconductors reserves the right to change the specification without notice, in order to improve the design and supply the best possible product.
III	Product data	Production	This data sheet contains data from the product specification. Philips Semiconductors reserves the right to make changes at any time in order to improve the design, manufacturing and supply. Relevant changes will be communicated via a Customer Product/Process Change Notification (CPCN).

[1] Please consult the most recently issued data sheet before initiating or completing a design.

[2] The product status of the device(s) described in this data sheet may have changed since this data sheet was published. The latest information is available on the Internet at URL <http://www.semiconductors.philips.com>.

[3] For data sheets describing multiple type numbers, the highest-level product status determines the data sheet status.

Definitions

Short-form specification — The data in a short-form specification is extracted from a full data sheet with the same type number and title. For detailed information see the relevant data sheet or data handbook.

Limiting values definition — Limiting values given are in accordance with the Absolute Maximum Rating System (IEC 60134). Stress above one or more of the limiting values may cause permanent damage to the device. These are stress ratings only and operation of the device at these or at any other conditions above those given in the Characteristics sections of the specification is not implied. Exposure to limiting values for extended periods may affect device reliability.

Application information — Applications that are described herein for any of these products are for illustrative purposes only. Philips Semiconductors make no representation or warranty that such applications will be suitable for the specified use without further testing or modification.

Disclaimers

Life support — These products are not designed for use in life support appliances, devices, or systems where malfunction of these products can reasonably be expected to result in personal injury. Philips Semiconductors customers using or selling these products for use in such applications do so at their own risk and agree to fully indemnify Philips Semiconductors for any damages resulting from such application.

Right to make changes — Philips Semiconductors reserves the right to make changes in the products—including circuits, standard cells, and/or software—described or contained herein in order to improve design and/or performance. When the product is in full production (status 'Production'), relevant changes will be communicated via a Customer Product/Process Change Notification (CPCN). Philips Semiconductors assumes no responsibility or liability for the use of any of these products, conveys no license or title under any patent, copyright, or mask work right to these products, and makes no representations or warranties that these products are free from patent, copyright, or mask work right infringement, unless otherwise specified.

Contact information

For additional information please visit
<http://www.semiconductors.philips.com>. Fax: +31 40 27 24825

For sales offices addresses send e-mail to:
sales.addresses@www.semiconductors.philips.com.

© Koninklijke Philips Electronics N.V. 2003
 All rights reserved. Printed in U.S.A.

p Date of release: 07-03

Document order number: 9397 750 11764

Let's make things better.