



Chipsmall Limited consists of a professional team with an average of over 10 year of expertise in the distribution of electronic components. Based in Hongkong, we have already established firm and mutual-benefit business relationships with customers from,Europe,America and south Asia,supplying obsolete and hard-to-find components to meet their specific needs.

With the principle of “Quality Parts,Customers Priority,Honest Operation,and Considerate Service”,our business mainly focus on the distribution of electronic components. Line cards we deal with include Microchip,ALPS,ROHM,Xilinx,Pulse,ON,Everlight and Freescale. Main products comprise IC,Modules,Potentiometer,IC Socket,Relay,Connector.Our parts cover such applications as commercial,industrial, and automotives areas.

We are looking forward to setting up business relationship with you and hope to provide you with the best service and solution. Let us make a better world for our industry!



Contact us

Tel: +86-755-8981 8866 Fax: +86-755-8427 6832

Email & Skype: info@chipsmall.com Web: www.chipsmall.com

Address: A1208, Overseas Decoration Building, #122 Zhenhua RD., Futian, Shenzhen, China



PCK940L

Low voltage 1 : 18 clock distribution chip

Rev. 01 — 4 April 2006

Product data sheet

1. General description

The PCK940L is a 1 : 18 low voltage clock distribution chip with 2.5 V or 3.3 V LVCMOS output capabilities. The device features the capability to select either a differential LVPECL or an LVCMOS compatible input. The 18 outputs are 2.5 V or 3.3 V LVCMOS compatible and feature the drive strength to drive 50 Ω series or parallel terminated transmission lines. With output-to-output skews of 150 ps, the PCK940L is ideal as a clock distribution chip for the most demanding of synchronous systems. The 2.5 V outputs also make the device ideal for supplying clocks for a high performance microprocessor based design.

With a low output impedance of approximately 20 Ω , in both the HIGH and LOW logic states, the output buffers of the PCK940L are ideal for driving series terminated transmission lines. With an output impedance of 20 Ω , the PCK940L has the capability of driving two series terminated transmission lines from each output. This gives the PCK940L an effective fan-out of 1 : 36. If a lower output impedance is desired, please see the PCK942C data sheet.

The differential LVPECL inputs of the PCK940L allow the device to interface directly with a LVPECL fan-out buffer like the PCKEP111 to build very wide clock fan-out trees or to couple to a high frequency clock source. The LVCMOS input provides a more standard interface for applications requiring only a single clock distribution chip at relatively low frequencies. In addition, the two clock sources can be used to provide for a test clock interface as well as the primary system clock. A logic HIGH on the LVCMOS_CLKSEL pin will select the LVCMOS level clock input. All inputs of the PCK940L have internal pull-up/pull-down resistors so they can be left open if unused.

The PCK940L is a single or dual supply device. The device power supply offers a high degree of flexibility. The device can operate with a 3.3 V core and 3.3 V output, a 3.3 V core and 2.5 V outputs, as well as a 2.5 V core and 2.5 V outputs. The 32-lead LQFP package was chosen to optimize performance, board space and cost of the device. The 32-lead LQFP package has a 7 mm \times 7 mm body size with a conservative 0.8 mm pin spacing.

2. Features

- LVPECL or LVCMOS clock input
- 2.5 V LVCMOS outputs for Pentium II microprocessor support
- 150 ps maximum output-to-output skew
- Maximum output frequency of 250 MHz at 3.3 V V_{CC}
- 32-lead LQFP packaging

PHILIPS

- Dual or single supply voltage:
 - ◆ Dual V_{CC} supply voltage, 3.3 V core and 2.5 V output
 - ◆ Single 3.3 V V_{CC} supply voltage for 3.3 V outputs
 - ◆ Single 2.5 V V_{CC} supply voltage for 2.5 V I/O

3. Ordering information

Table 1. Ordering information

Type number	Package		
	Name	Description	Version
PCK940LBD	LQFP32	plastic low profile quad flat package; 32 leads; body $7 \times 7 \times 1.4$ mm	SOT358-1

4. Functional diagram

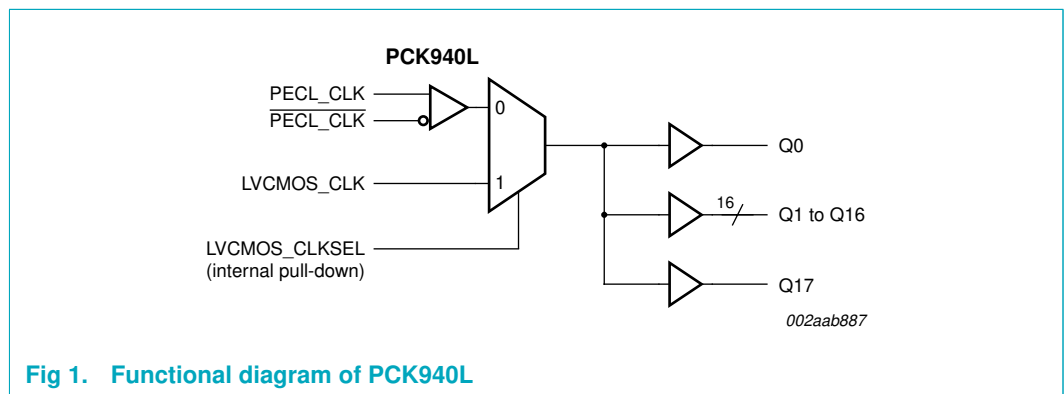

5. Pinning information

5.1 Pinning

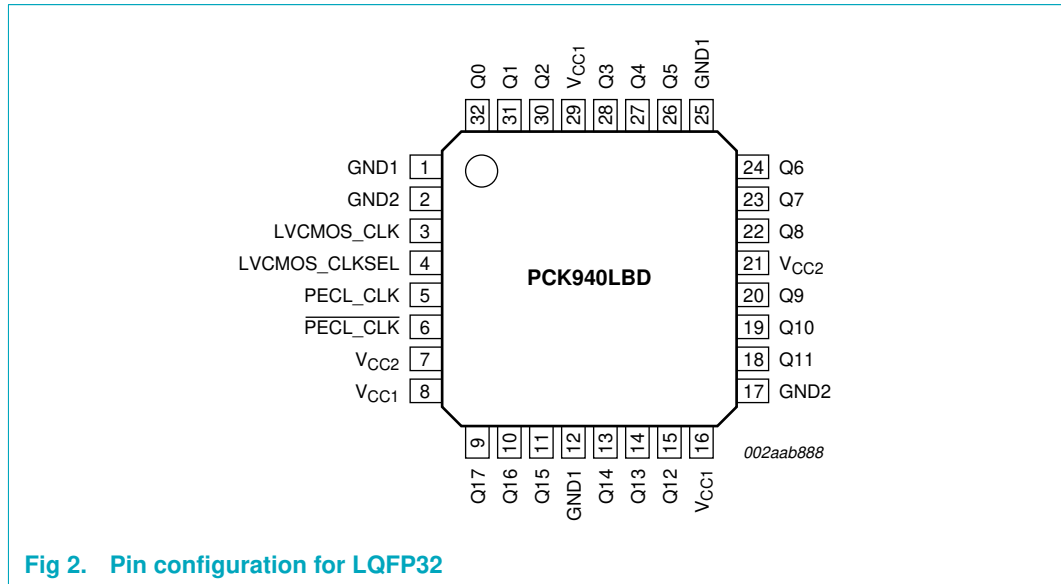

Fig 2. Pin configuration for LQFP32

5.2 Pin description

Table 2. Pin description

Symbol	Pin	I/O	Type	Description
PECL_CLK	5	input	LVPECL	reference clock input
$\overline{\text{PECL_CLK}}$	6	input	LVPECL	reference clock input (active LOW)
LVC MOS_CLK	3	input	LVC MOS	alternative reference clock input
LVC MOS_CLKSEL	4	input	LVC MOS	clock source select
Q0 to Q17	32, 31, 30, 28, 27, 26, 24, 23, 22, 20, 19, 18, 15, 14, 11, 10, 9	output	LVC MOS	clock outputs
GND1	1, 12, 25	-	supply	output negative power supply
GND2	2, 17	-	supply	core negative power supply
V _{CC1}	8, 16, 29	-	supply	output positive power supply
V _{CC2}	7, 21	-	supply	core positive power supply

6. Functional description

Refer to [Figure 1 “Functional diagram of PCK940L”](#).

6.1 Function table

Table 3. Function table

LVC MOS_CLKSEL	Input
0	PECL_CLK
1	LVC MOS_CLK

Table 4. Power supply voltage

Supply pin	Voltage level
V _{CC2}	2.5 V or 3.3 V ± 5 %
V _{CC1}	2.5 V or 3.3 V ± 5 %

7. Limiting values

Table 5. Limiting values

In accordance with the Absolute Maximum Rating System (IEC 60134).

Symbol	Parameter	Conditions	Min	Max	Unit
V _{CC}	supply voltage		-0.3	+3.6	V
V _I	input voltage		-0.3	V _{DD} + 0.3	V
I _I	input current		-	±20	mA
T _{stg}	storage temperature		-40	+125	°C

8. Static characteristics

Table 6. Static characteristics (3.3 V V_{CC}, 3.3 V outputs)

T_{amb} = 0 °C to 70 °C; V_{CC2} = 3.3 V ± 5 %; V_{CC1} = 3.3 V ± 5 %

Symbol	Parameter	Conditions	Min	Typ	Max	Unit
V _{IH}	HIGH-level input voltage	LVC MOS_CLK	2.4	-	V _{CC2}	V
V _{IL}	LOW-level input voltage	LVC MOS_CLK	-	-	0.8	V
V _{i(p-p)}	peak-to-peak input voltage	PECL_CLK	500	-	1000	mV
V _{ICR}	common mode input voltage range	PECL_CLK	V _{CC} - 1.4	-	V _{CC} - 0.6	V
V _{OH}	HIGH-level output voltage	I _{OH} = -20 mA	2.4	-	-	V
V _{OL}	LOW-level output voltage	I _{OH} = 20 mA	-	-	0.5	V
I _I	input current		-	-	±200	µA
C _i	input capacitance		-	4.0	-	pF
C _{PD}	power dissipation capacitance	per output	-	10	-	pF
Z _o	output impedance		18	23	28	Ω
I _{CC(max)}	maximum supply current		-	0.5	1.0	mA

Table 7. Static characteristics (3.3 V V_{CC} , 2.5 V outputs) $T_{amb} = 0\text{ }^{\circ}\text{C to }70\text{ }^{\circ}\text{C}; V_{CC2} = 3.3\text{ V} \pm 5\%; V_{CC1} = 2.5\text{ V} \pm 5\%$

Symbol	Parameter	Conditions	Min	Typ	Max	Unit
V_{IH}	HIGH-level input voltage	LVC MOS_CLK	2.4	-	V_{CC2}	V
V_{IL}	LOW-level input voltage	LVC MOS_CLK	-	-	0.8	V
$V_{i(p-p)}$	peak-to-peak input voltage	PECL_CLK	500	-	1000	mV
V_{ICR}	common mode input voltage range	PECL_CLK	$V_{CC} - 1.4$	-	$V_{CC} - 0.6$	V
V_{OH}	HIGH-level output voltage	$I_{OH} = -20\text{ mA}$	1.8	-	-	V
V_{OL}	LOW-level output voltage	$I_{OH} = 20\text{ mA}$	-	-	0.5	V
I_I	input current		-	-	± 200	μA
C_i	input capacitance		-	4.0	-	pF
C_{PD}	power dissipation capacitance	per output	-	10	-	pF
Z_o	output impedance		-	23	-	Ω
$I_{CC(max)}$	maximum supply current		-	0.5	1.0	mA

Table 8. Static characteristics (2.5 V V_{CC} , 2.5 V output) $T_{amb} = 0\text{ }^{\circ}\text{C to }70\text{ }^{\circ}\text{C}; V_{CC2} = 2.5\text{ V} \pm 5\%; V_{CC1} = 2.5\text{ V} \pm 5\%$

Symbol	Parameter	Conditions	Min	Typ	Max	Unit
V_{IH}	HIGH-level input voltage	LVC MOS_CLK	2.0	-	V_{CC2}	V
V_{IL}	LOW-level input voltage	LVC MOS_CLK	-	-	0.8	V
$V_{i(p-p)}$	peak-to-peak input voltage	PECL_CLK	500	-	1000	mV
V_{ICR}	common mode input voltage range	PECL_CLK	$V_{CC} - 1.0$	-	$V_{CC} - 0.6$	V
V_{OH}	HIGH-level output voltage	$I_{OH} = -20\text{ mA}$	1.8	-	-	V
V_{OL}	LOW-level output voltage	$I_{OH} = 20\text{ mA}$	-	-	0.5	V
I_I	input current		-	-	± 200	μA
C_i	input capacitance		-	4.0	-	pF
C_{PD}	power dissipation capacitance	per output	-	10	-	pF
Z_o	output impedance		18	23	28	Ω
$I_{CC(max)}$	maximum supply current		-	0.5	1.0	mA

9. Dynamic characteristics

Table 9. Dynamic characteristics (3.3 V V_{CC} , 3.3 V output)

$T_{amb} = 0\text{ }^{\circ}\text{C}$ to $70\text{ }^{\circ}\text{C}$; $V_{CC2} = 3.3\text{ V} \pm 5\%$; $V_{CC1} = 3.3\text{ V} \pm 5\%$

Symbol	Parameter	Conditions	Min	Typ	Max	Unit
$f_{oper(max)}$	maximum operating frequency		-	-	250	MHz
t_{PLH}	LOW-to-HIGH propagation delay	PECL_CLK \leq 150 MHz	[1] 2.0	2.7	3.8	ns
		LVCOSMOS_CLK \leq 150 MHz	[1] 1.8	2.5	3.0	ns
		PECL_CLK $>$ 150 MHz	2.0	2.9	3.7	ns
		LVCOSMOS_CLK $>$ 150 MHz	1.8	2.4	3.2	ns
$t_{sk(o)}$	output skew time	output-to-output				
		PECL_CLK	[1] -	-	200	ps
		LVCOSMOS_CLK	[1] -	-	150	ps
$t_{sk(pr)}$	process skew time	part-to-part				
		PECL_CLK $<$ 150 MHz	[1][2] -	-	1.4	ns
		LVCOSMOS_CLK $<$ 150 MHz	[1][2] -	-	1.2	ns
		PECL_CLK $>$ 150 MHz	[1][2] -	-	1.7	ns
		LVCOSMOS_CLK $>$ 150 MHz	[1][2] -	-	1.4	ns
		PECL_CLK	[1][3] -	-	850	ps
		LVCOSMOS_CLK	[1][3] -	-	750	ps
δ_o	output duty cycle	LVCOSMOS_CLK; input $\delta = 50\%$				
		$f_{clk} < 134\text{ MHz}$	45	50	55	%
		$f_{clk} \leq 250\text{ MHz}$	40	50	60	%
		PECL_CLK; input $\delta = 50\%$				
		$f_{clk} < 134\text{ MHz}$	35	50	65	%
		$f_{clk} \leq 250\text{ MHz}$	40	50	60	%
t_r	rise time	output; from 0.5 V to 2.4 V	0.3	-	1.1	ns
t_f	fall time	output; from 2.4 V to 0.5 V	0.3	-	1.1	ns

[1] Tested using standard input levels, production tested at 150 MHz.

[2] Across temperature and voltage ranges, includes output skew.

[3] For a specific temperature and voltage, includes output skew.

Table 10. Dynamic characteristics (3.3 V V_{CC} , 2.5 V output) $T_{amb} = 0\text{ }^{\circ}\text{C to }70\text{ }^{\circ}\text{C}; V_{CC2} = 3.3\text{ V} \pm 5\%; V_{CC1} = 2.5\text{ V} \pm 5\%$

Symbol	Parameter	Conditions	Min	Typ	Max	Unit
$f_{oper(max)}$	maximum operating frequency		-	-	250	MHz
t_{PLH}	LOW-to-HIGH propagation delay	PECL_CLK \leq 150 MHz	[1] 2.0	2.8	4.0	ns
		LVC MOS_CLK \leq 150 MHz	[1] 1.7	2.5	3.0	ns
		PECL_CLK $>$ 150 MHz	2.0	2.9	4.0	ns
		LVC MOS_CLK $>$ 150 MHz	1.8	2.5	3.3	ns
$t_{sk(o)}$	output skew time	output-to-output				
		PECL_CLK	[1] -	-	300	ps
		LVC MOS_CLK	[1] -	-	150	ps
$t_{sk(pr)}$	process skew time	part-to-part				
		PECL_CLK $<$ 150 MHz	[1][2] -	-	1.5	ns
		LVC MOS_CLK $<$ 150 MHz	[1][2] -	-	1.3	ns
		PECL_CLK $>$ 150 MHz	[1][2] -	-	1.8	ns
		LVC MOS_CLK $>$ 150 MHz	[1][2] -	-	1.5	ns
		PECL_CLK	[1][3] -	-	850	ps
δ_o	output duty cycle	LVC MOS_CLK; input $\delta = 50\%$				
		$f_{clk} < 134\text{ MHz}$	45	50	55	%
		$f_{clk} \leq 250\text{ MHz}$	40	50	60	%
		PECL_CLK; input $\delta = 50\%$				
		$f_{clk} < 134\text{ MHz}$	35	50	65	%
		$f_{clk} \leq 250\text{ MHz}$	40	50	60	%
t_r	rise time	output; from 0.5 V to 1.8 V	0.3	-	1.2	ns
t_f	fall time	output; from 1.8 V to 0.5 V	0.3	-	1.2	ns

[1] Tested using standard input levels, production tested at 150 MHz.

[2] Across temperature and voltage ranges, includes output skew.

[3] For a specific temperature and voltage, includes output skew.

Table 11. Dynamic characteristics (2.5 V V_{CC} , 2.5 V output) $T_{amb} = 0\text{ }^{\circ}\text{C to }70\text{ }^{\circ}\text{C}; V_{CC2} = 2.5\text{ V} \pm 5\%; V_{CC1} = 2.5\text{ V} \pm 5\%$

Symbol	Parameter	Conditions	Min	Typ	Max	Unit
$f_{oper(max)}$	maximum operating frequency		-	-	200	MHz
t_{PLH}	LOW-to-HIGH propagation delay	PECL_CLK \leq 150 MHz	[1] 2.6	4.0	5.2	ns
		LVC MOS_CLK \leq 150 MHz	[1] 2.3	3.1	4.0	ns
		PECL_CLK $>$ 150 MHz	2.8	3.8	5.0	ns
		LVC MOS_CLK $>$ 150 MHz	2.3	3.1	4.0	ns
$t_{sk(o)}$	output skew time	output-to-output				
		PECL_CLK	[1] -	-	300	ps
		LVC MOS_CLK	[1] -	-	200	ps
$t_{sk(pr)}$	process skew time	part-to-part				
		PECL_CLK $<$ 150 MHz	[1][2] -	-	2.6	ns
		LVC MOS_CLK $<$ 150 MHz	[1][2] -	-	1.7	ns
		PECL_CLK $>$ 150 MHz	[1][2] -	-	2.2	ns
		LVC MOS_CLK $>$ 150 MHz	[1][2] -	-	1.7	ns
		PECL_CLK	[1][3] -	-	1.2	ns
δ_o	output duty cycle	LVC MOS_CLK; input $\delta = 50\%$				
		$f_{clk} < 134\text{ MHz}$	45	50	55	%
		$f_{clk} \leq 250\text{ MHz}$	40	50	60	%
		PECL_CLK; input $\delta = 50\%$				
		$f_{clk} < 134\text{ MHz}$	35	50	65	%
		$f_{clk} \leq 250\text{ MHz}$	40	50	60	%
t_r	rise time	output; from 0.5 V to 1.8 V	0.3	-	1.2	ns
t_f	fall time	output; from 1.8 V to 0.5 V	0.3	-	1.2	ns

[1] Tested using standard input levels, production tested at 150 MHz.

[2] Across temperature and voltage ranges, includes output skew.

[3] For a specific temperature and voltage, includes output skew.

9.1 Timing diagrams

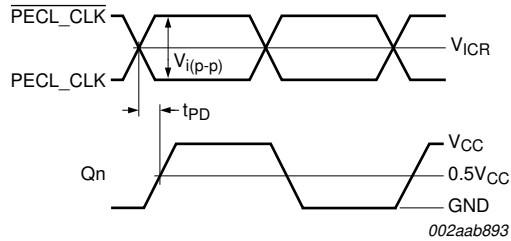

Fig 3. Propagation delay (t_{PD}) test reference

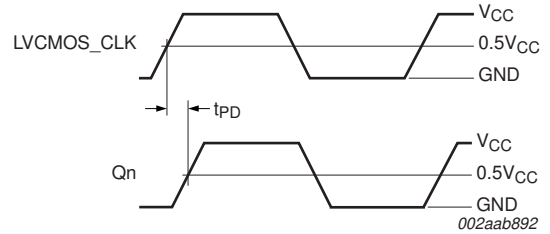
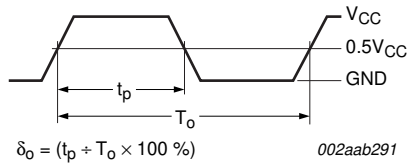
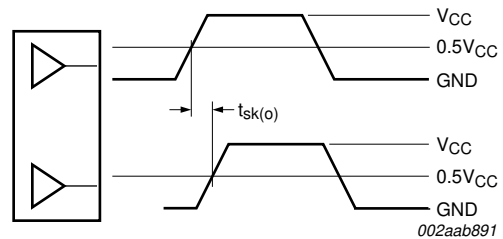

Fig 4. LVC MOS_CLK propagation delay (t_{PD}) test reference



The time from the PLL controlled edge to the non-controlled edge, divided by the time between PLL controlled edges, expressed as a percentage.

Fig 5. Output duty cycle



The pin-to-pin skew is defined as the worst-case difference in propagation delay between any two similar delay paths within a single device.

Fig 6. Output-to-output skew

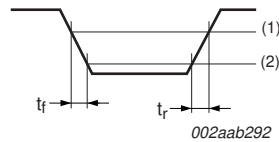

- (1) output 2.4 V; input 2.0 V ($V_{CC} = 3.3$ V)
output 1.8 V; input 1.7 V ($V_{CC} = 2.5$ V)
- (2) output 0.55 V; input 0.8 V ($V_{CC} = 3.3$ V)
output 0.6 V; input 0.7 V ($V_{CC} = 2.5$ V)

Fig 7. Transition time test reference

10. Test information

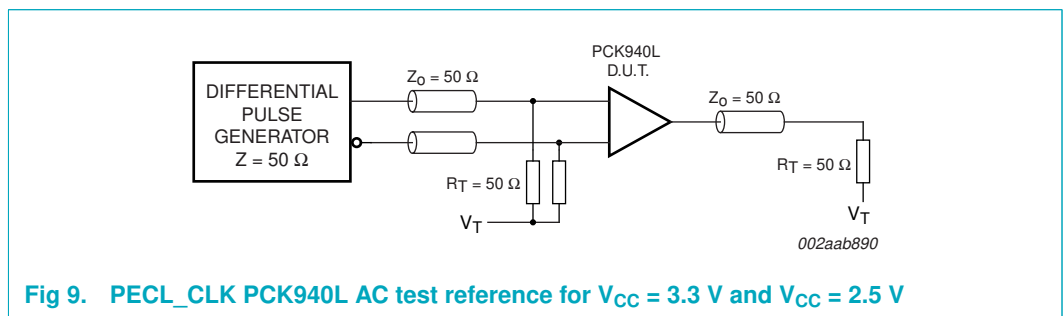
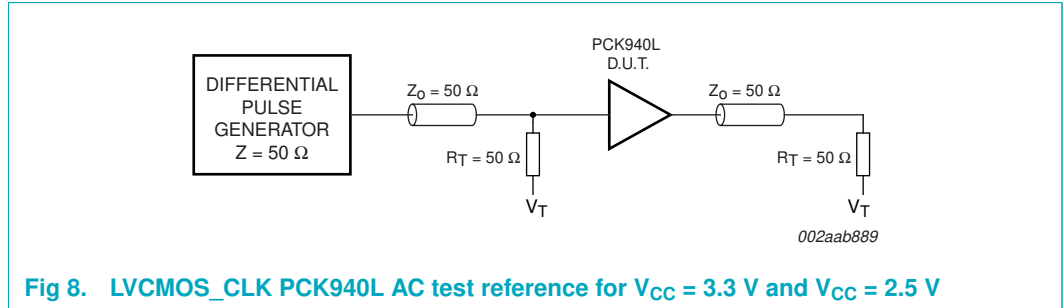

11. Package outline

LQFP32: plastic low profile quad flat package; 32 leads; body 7 x 7 x 1.4 mm

SOT358-1

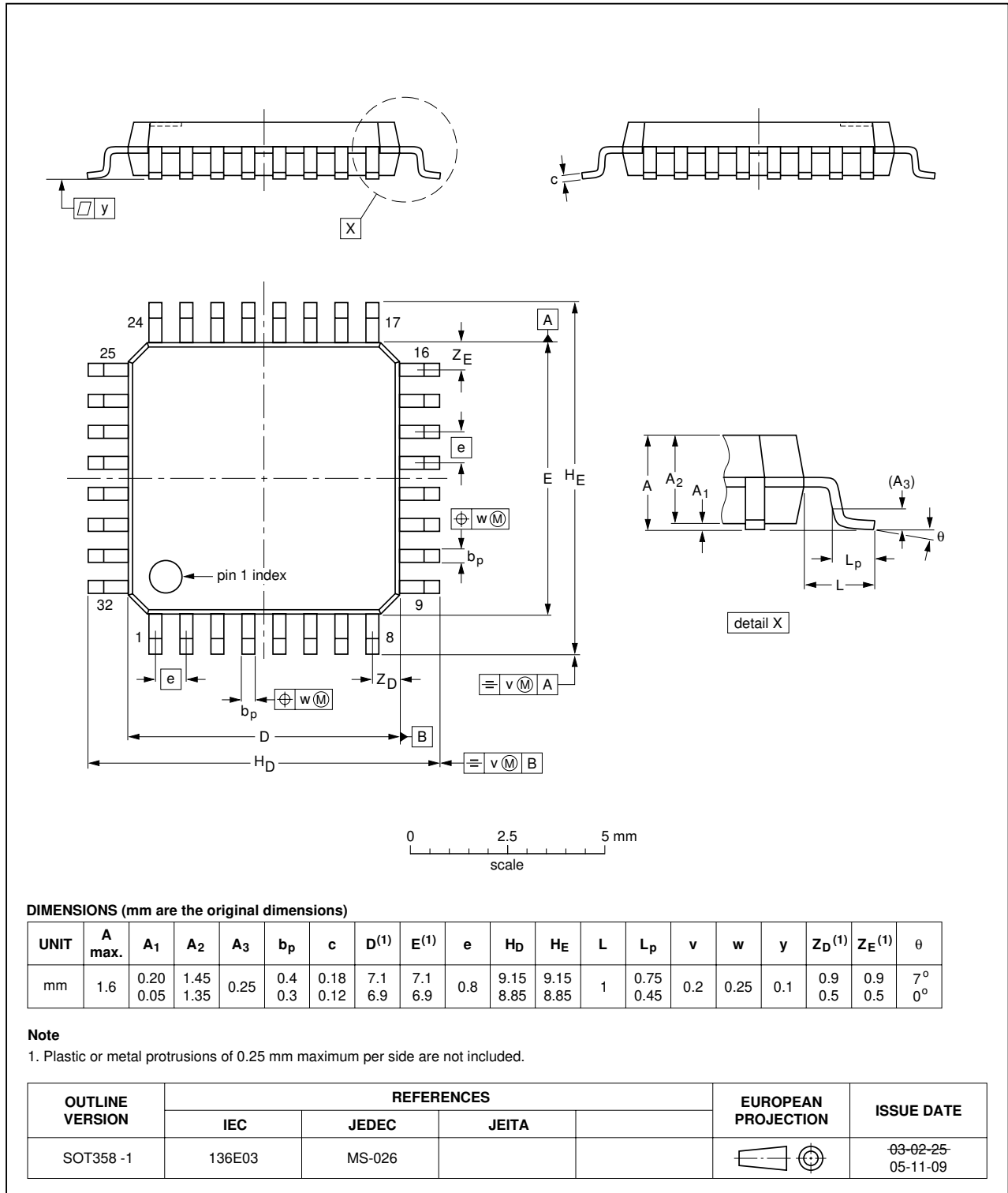

Fig 10. Package outline SOT358-1 (LQFP32)

12. Soldering

12.1 Introduction to soldering surface mount packages

This text gives a very brief insight to a complex technology. A more in-depth account of soldering ICs can be found in our *Data Handbook IC26; Integrated Circuit Packages* (document order number 9398 652 90011).

There is no soldering method that is ideal for all surface mount IC packages. Wave soldering can still be used for certain surface mount ICs, but it is not suitable for fine pitch SMDs. In these situations reflow soldering is recommended.

12.2 Reflow soldering

Reflow soldering requires solder paste (a suspension of fine solder particles, flux and binding agent) to be applied to the printed-circuit board by screen printing, stencilling or pressure-syringe dispensing before package placement. Driven by legislation and environmental forces the worldwide use of lead-free solder pastes is increasing.

Several methods exist for reflowing; for example, convection or convection/infrared heating in a conveyor type oven. Throughput times (preheating, soldering and cooling) vary between 100 seconds and 200 seconds depending on heating method.

Typical reflow peak temperatures range from 215 °C to 260 °C depending on solder paste material. The top-surface temperature of the packages should preferably be kept:

- below 225 °C (SnPb process) or below 245 °C (Pb-free process)
 - for all BGA, HTSSON..T and SSOP..T packages
 - for packages with a thickness ≥ 2.5 mm
 - for packages with a thickness < 2.5 mm and a volume ≥ 350 mm³ so called thick/large packages.
- below 240 °C (SnPb process) or below 260 °C (Pb-free process) for packages with a thickness < 2.5 mm and a volume < 350 mm³ so called small/thin packages.

Moisture sensitivity precautions, as indicated on packing, must be respected at all times.

12.3 Wave soldering

Conventional single wave soldering is not recommended for surface mount devices (SMDs) or printed-circuit boards with a high component density, as solder bridging and non-wetting can present major problems.

To overcome these problems the double-wave soldering method was specifically developed.

If wave soldering is used the following conditions must be observed for optimal results:

- Use a double-wave soldering method comprising a turbulent wave with high upward pressure followed by a smooth laminar wave.
- For packages with leads on two sides and a pitch (e):
 - larger than or equal to 1.27 mm, the footprint longitudinal axis is **preferred** to be parallel to the transport direction of the printed-circuit board;

- smaller than 1.27 mm, the footprint longitudinal axis **must** be parallel to the transport direction of the printed-circuit board.

The footprint must incorporate solder thieves at the downstream end.

- For packages with leads on four sides, the footprint must be placed at a 45° angle to the transport direction of the printed-circuit board. The footprint must incorporate solder thieves downstream and at the side corners.

During placement and before soldering, the package must be fixed with a droplet of adhesive. The adhesive can be applied by screen printing, pin transfer or syringe dispensing. The package can be soldered after the adhesive is cured.

Typical dwell time of the leads in the wave ranges from 3 seconds to 4 seconds at 250 °C or 265 °C, depending on solder material applied, SnPb or Pb-free respectively.

A mildly-activated flux will eliminate the need for removal of corrosive residues in most applications.

12.4 Manual soldering

Fix the component by first soldering two diagonally-opposite end leads. Use a low voltage (24 V or less) soldering iron applied to the flat part of the lead. Contact time must be limited to 10 seconds at up to 300 °C.

When using a dedicated tool, all other leads can be soldered in one operation within 2 seconds to 5 seconds between 270 °C and 320 °C.

12.5 Package related soldering information

Table 12. Suitability of surface mount IC packages for wave and reflow soldering methods

Package ^[1]	Soldering method	
	Wave	Reflow ^[2]
BGA, HTSSON..T ^[3] , LBGA, LFBGA, SQFP, SSOP..T ^[3] , TFBGA, VFBGA, XSON	not suitable	suitable
DHVQFN, HBCC, HBGA, HLQFP, HSO, HSOP, HSQFP, HSSON, HTQFP, HTSSOP, HVQFN, HVSON, SMS	not suitable ^[4]	suitable
PLCC ^[5] , SO, SOJ	suitable	suitable
LQFP, QFP, TQFP	not recommended ^{[5][6]}	suitable
SSOP, TSSOP, VSO, VSSOP	not recommended ^[7]	suitable
CWQCCN..L ^[8] , PMFP ^[9] , WQCCN..L ^[8]	not suitable	not suitable

[1] For more detailed information on the BGA packages refer to the (LF)BGA Application Note (AN01026); order a copy from your Philips Semiconductors sales office.

[2] All surface mount (SMD) packages are moisture sensitive. Depending upon the moisture content, the maximum temperature (with respect to time) and body size of the package, there is a risk that internal or external package cracks may occur due to vaporization of the moisture in them (the so called popcorn effect). For details, refer to the Drypack information in the *Data Handbook IC26; Integrated Circuit Packages; Section: Packing Methods*.

[3] These transparent plastic packages are extremely sensitive to reflow soldering conditions and must on no account be processed through more than one soldering cycle or subjected to infrared reflow soldering with peak temperature exceeding 217 °C ± 10 °C measured in the atmosphere of the reflow oven. The package body peak temperature must be kept as low as possible.

- [4] These packages are not suitable for wave soldering. On versions with the heatsink on the bottom side, the solder cannot penetrate between the printed-circuit board and the heatsink. On versions with the heatsink on the top side, the solder might be deposited on the heatsink surface.
- [5] If wave soldering is considered, then the package must be placed at a 45° angle to the solder wave direction. The package footprint must incorporate solder thieves downstream and at the side corners.
- [6] Wave soldering is suitable for LQFP, QFP and TQFP packages with a pitch (e) larger than 0.8 mm; it is definitely not suitable for packages with a pitch (e) equal to or smaller than 0.65 mm.
- [7] Wave soldering is suitable for SSOP, TSSOP, VSO and VSSOP packages with a pitch (e) equal to or larger than 0.65 mm; it is definitely not suitable for packages with a pitch (e) equal to or smaller than 0.5 mm.
- [8] Image sensor packages in principle should not be soldered. They are mounted in sockets or delivered pre-mounted on flex foil. However, the image sensor package can be mounted by the client on a flex foil by using a hot bar soldering process. The appropriate soldering profile can be provided on request.
- [9] Hot bar soldering or manual soldering is suitable for PMFP packages.

13. Abbreviations

Table 13. Abbreviations

Acronym	Description
LVMOS	Low Voltage Complementary Metal Oxide Semiconductor
LVPECL	Low Voltage Positive Emitter Coupled Logic
PLL	Phase-Locked Loop

14. Revision history

Table 14. Revision history

Document ID	Release date	Data sheet status	Change notice	Supersedes
PCK940L_1	20060404	Product data sheet	-	-

15. Legal information

15.1 Data sheet status

Document status ^{[1][2]}	Product status ^[3]	Definition
Objective [short] data sheet	Development	This document contains data from the objective specification for product development.
Preliminary [short] data sheet	Qualification	This document contains data from the preliminary specification.
Product [short] data sheet	Production	This document contains the product specification.

[1] Please consult the most recently issued document before initiating or completing a design.

[2] The term 'short data sheet' is explained in section "Definitions".

[3] The product status of device(s) described in this document may have changed since this document was published and may differ in case of multiple devices. The latest product status information is available on the Internet at URL <http://www.semiconductors.philips.com>.

15.2 Definitions

Draft — The document is a draft version only. The content is still under internal review and subject to formal approval, which may result in modifications or additions. Philips Semiconductors does not give any representations or warranties as to the accuracy or completeness of information included herein and shall have no liability for the consequences of use of such information.

Short data sheet — A short data sheet is an extract from a full data sheet with the same product type number(s) and title. A short data sheet is intended for quick reference only and should not be relied upon to contain detailed and full information. For detailed and full information see the relevant full data sheet, which is available on request via the local Philips Semiconductors sales office. In case of any inconsistency or conflict with the short data sheet, the full data sheet shall prevail.

15.3 Disclaimers

General — Information in this document is believed to be accurate and reliable. However, Philips Semiconductors does not give any representations or warranties, expressed or implied, as to the accuracy or completeness of such information and shall have no liability for the consequences of use of such information.

Right to make changes — Philips Semiconductors reserves the right to make changes to information published in this document, including without limitation specifications and product descriptions, at any time and without notice. This document supersedes and replaces all information supplied prior to the publication hereof.

Suitability for use — Philips Semiconductors products are not designed, authorized or warranted to be suitable for use in medical, military, aircraft, space or life support equipment, nor in applications where failure or

malfunction of a Philips Semiconductors product can reasonably be expected to result in personal injury, death or severe property or environmental damage. Philips Semiconductors accepts no liability for inclusion and/or use of Philips Semiconductors products in such equipment or applications and therefore such inclusion and/or use is for the customer's own risk.

Applications — Applications that are described herein for any of these products are for illustrative purposes only. Philips Semiconductors makes no representation or warranty that such applications will be suitable for the specified use without further testing or modification.

Limiting values — Stress above one or more limiting values (as defined in the Absolute Maximum Ratings System of IEC 60134) may cause permanent damage to the device. Limiting values are stress ratings only and operation of the device at these or any other conditions above those given in the Characteristics sections of this document is not implied. Exposure to limiting values for extended periods may affect device reliability.

Terms and conditions of sale — Philips Semiconductors products are sold subject to the general terms and conditions of commercial sale, as published at <http://www.semiconductors.philips.com/profile/terms>, including those pertaining to warranty, intellectual property rights infringement and limitation of liability, unless explicitly otherwise agreed to in writing by Philips Semiconductors. In case of any inconsistency or conflict between information in this document and such terms and conditions, the latter will prevail.

No offer to sell or license — Nothing in this document may be interpreted or construed as an offer to sell products that is open for acceptance or the grant, conveyance or implication of any license under any copyrights, patents or other industrial or intellectual property rights.

15.4 Trademarks

Notice: All referenced brands, product names, service names and trademarks are the property of their respective owners.

16. Contact information

For additional information, please visit: <http://www.semiconductors.philips.com>

For sales office addresses, send an email to: sales.addresses@www.semiconductors.philips.com

17. Contents

1	General description	1
2	Features	1
3	Ordering information	2
4	Functional diagram	2
5	Pinning information	3
5.1	Pinning	3
5.2	Pin description	3
6	Functional description	4
6.1	Function table	4
7	Limiting values	4
8	Static characteristics	4
9	Dynamic characteristics	6
9.1	Timing diagrams	9
10	Test information	10
11	Package outline	11
12	Soldering	12
12.1	Introduction to soldering surface mount packages	12
12.2	Reflow soldering	12
12.3	Wave soldering	12
12.4	Manual soldering	13
12.5	Package related soldering information	13
13	Abbreviations	14
14	Revision history	14
15	Legal information	15
15.1	Data sheet status	15
15.2	Definitions	15
15.3	Disclaimers	15
15.4	Trademarks	15
16	Contact information	15
17	Contents	16



Please be aware that important notices concerning this document and the product(s) described herein, have been included in section 'Legal information'.

© Koninklijke Philips Electronics N.V. 2006. All rights reserved.

For more information, please visit: <http://www.semiconductors.philips.com>.

For sales office addresses, email to: sales.addresses@www.semiconductors.philips.com.

Date of release: 4 April 2006

Document identifier: PCK940L_1