



Chipsmall Limited consists of a professional team with an average of over 10 year of expertise in the distribution of electronic components. Based in Hongkong, we have already established firm and mutual-benefit business relationships with customers from,Europe,America and south Asia,supplying obsolete and hard-to-find components to meet their specific needs.

With the principle of "Quality Parts,Customers Priority,Honest Operation,and Considerate Service",our business mainly focus on the distribution of electronic components. Line cards we deal with include Microchip,ALPS,ROHM,Xilinx,Pulse,ON,Everlight and Freescale. Main products comprise IC,Modules,Potentiometer,IC Socket,Relay,Connector.Our parts cover such applications as commercial,industrial, and automotives areas.

We are looking forward to setting up business relationship with you and hope to provide you with the best service and solution. Let us make a better world for our industry!



Contact us

Tel: +86-755-8981 8866 Fax: +86-755-8427 6832

Email & Skype: info@chipsmall.com Web: www.chipsmall.com

Address: A1208, Overseas Decoration Building, #122 Zhenhua RD., Futian, Shenzhen, China



PCM Series Ultraminiature Surface Mount Slide Switches

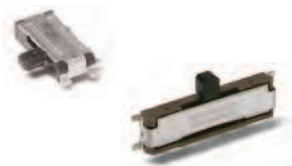

Features/Benefits

- Ultraminiature surface mount
- Low profile
- SPDT & SP3T models
- RoHS compliant

Typical Applications

- Computer peripherals & network products
- Telecommunication products
- Test & measurement equipment

Specifications

CONTACT RATING: 0.3A @ 6 VDC.
 MECHANICAL LIFE: 10,000 cycles.
 CONTACT RESISTANCE: 70 m Ω max.
 INSULATION RESISTANCE: 100 M Ω min. @ 500V.
 DIELECTRIC STRENGTH: 500 VAC min.
 OPERATING TEMPERATURE: -20°C to +85°C.
 SOLDERABILITY: 255C max. solder temperature.
 PACKAGING: Tape & reel.

Materials

CASE: PA6T
 COVER: Stainless steel.
 SLIDER: Nylon 4/6
 BRUSH: Copper alloy silver clad.
 TERMINALS: Copper alloy, silver plated.

NOTE: All models RoHS compliant and compatible with all options.

NOTE: Specifications and materials listed above are for switches with standard options. For information on specific and custom switches, consult Customer Service Center.

How To Order

Complete part numbers for PCM Series Ultraminiature Surface Mount Slide Switches are shown below and on page I-45.

PC MOUNTING

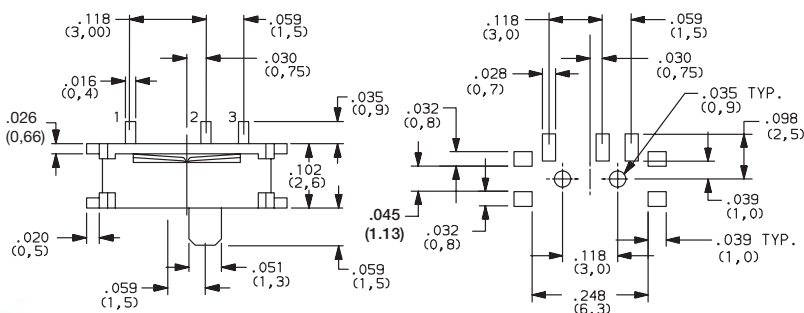

PCM12SMTR
SPDT

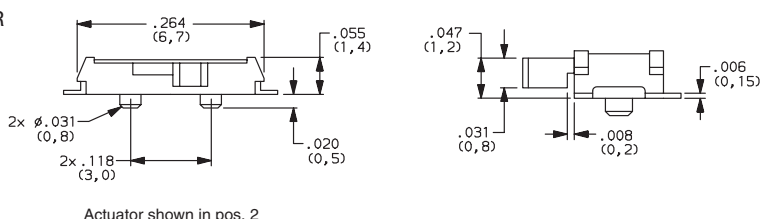

PART NUMBER	SWITCH FUNCTION	
	POS. 1	POS. 2
PCM12SMTR	ON	ON
CONN. TERMINALS	1-2	2-3
SCHEMATIC		
SPDT		

TAPE & REEL

For part number PCM12SMTR

Quantity per reel 3500

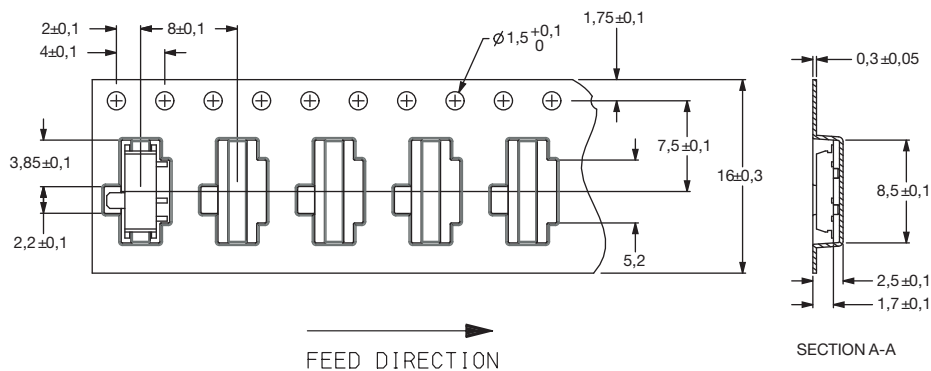

Dimensions are shown: Inch (mm)
 Specifications and dimensions subject to change

PCM Series Ultraminiature Surface Mount Slide Switches

PART NUMBER	SWITCH FUNCTION		
	POS. 1	POS. 2	POS. 3
PCM13SMTR	ON	ON	ON
CONN. TERMINALS	1-3	2-3	3-4
SCHEMATIC			
SP3T			

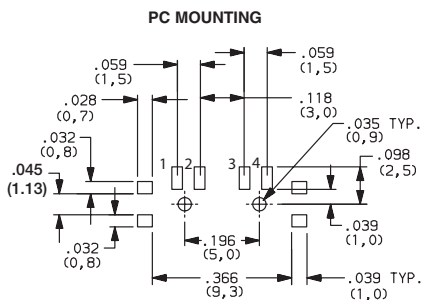
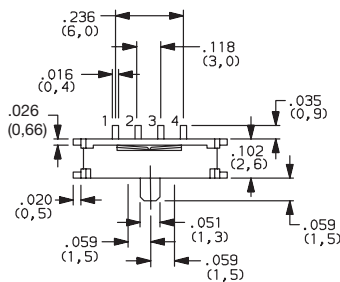

PCM13SMTR
SP3T

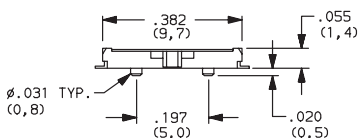

Actuator shown in pos. 2

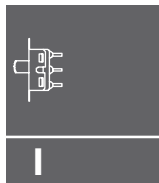
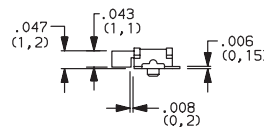

Slide

TAPE & REEL

For part number PCM13SMTR

Quantity per reel 3500

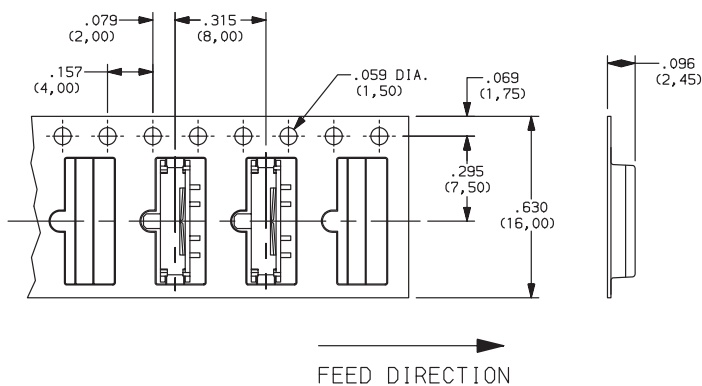

Third Angle Projection
Dimensions are shown: Inches (mm)
Specifications and dimensions subject to change