



Chipsmall Limited consists of a professional team with an average of over 10 year of expertise in the distribution of electronic components. Based in Hongkong, we have already established firm and mutual-benefit business relationships with customers from,Europe,America and south Asia,supplying obsolete and hard-to-find components to meet their specific needs.

With the principle of “Quality Parts,Customers Priority,Honest Operation,and Considerate Service”,our business mainly focus on the distribution of electronic components. Line cards we deal with include Microchip,ALPS,ROHM,Xilinx,Pulse,ON,Everlight and Freescale. Main products comprise IC,Modules,Potentiometer,IC Socket,Relay,Connector.Our parts cover such applications as commercial,industrial, and automotives areas.

We are looking forward to setting up business relationship with you and hope to provide you with the best service and solution. Let us make a better world for our industry!



## Contact us

Tel: +86-755-8981 8866 Fax: +86-755-8427 6832

Email & Skype: info@chipsmall.com Web: www.chipsmall.com

Address: A1208, Overseas Decoration Building, #122 Zhenhua RD., Futian, Shenzhen, China





## Multi-Output Clock Synthesizer

### Features

- Generates multiple clock outputs from an inexpensive 25MHz crystal or external reference clock
- Frequency outputs:
  - 25MHz Reference clock
  - 125MHz
  - 127MHz
- Zero ppm frequency synthesis error for all CLK outputs
- 3.3V ± 5%V Supply Voltage
- Low jitter design
- Packaged in 16-pin TSSOP
- Compatible with CY22393XC-MZ2
- Advanced CMOS process

### Product Description

The PCS1P2860A is a Precision multi-PLL based frequency synthesizer. Six Clock outputs are generated using an inexpensive 25MHz Crystal or external reference clock. The outputs consist of 25MHz Refout, 127MHz and four 125MHz clocks. SHUTDOWNB signal tri-states all the clocks when enabled. The device operates from a Supply Voltage of 3.3V ± 5%. The device is available in a 16-pin TSSOP JEDEC package.

### Application

PCS1P2860A is targeted for use in high-end multimedia, communications and consumer applications.

### Block Diagram

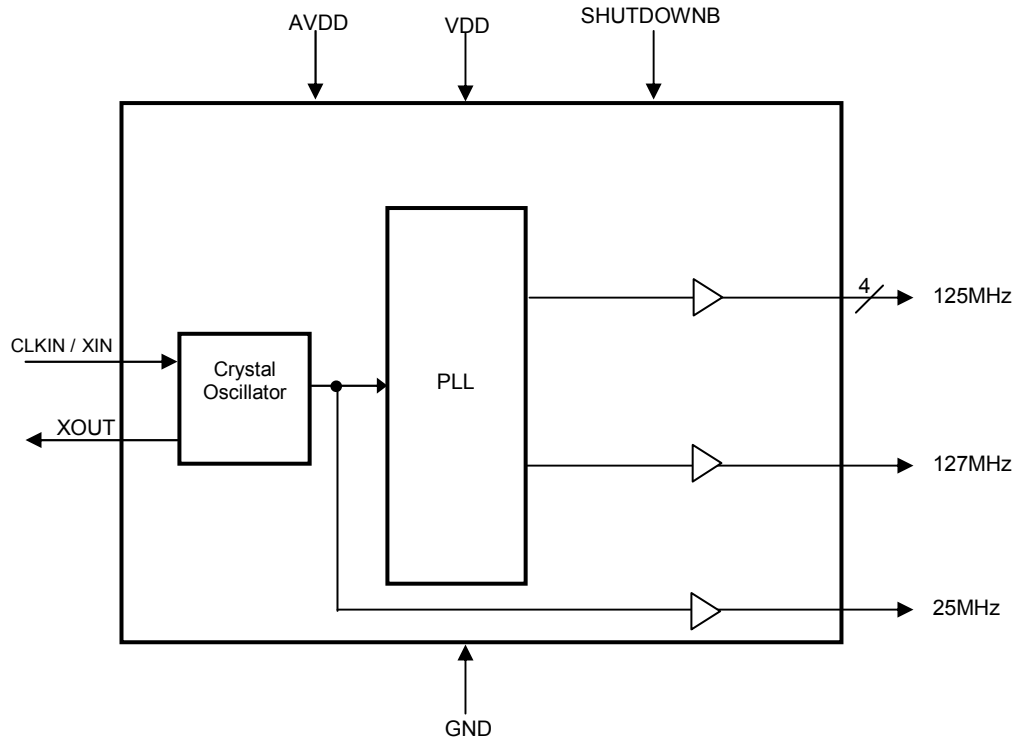

## Pin Diagram

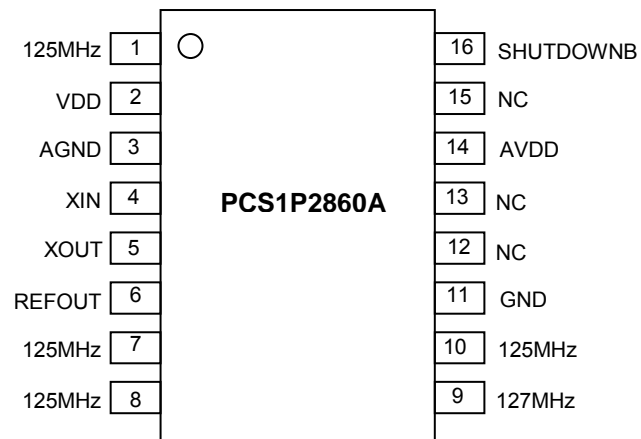

## Pin Description

Pin #	Pin Name	Pin Type	Pin Description
1	125MHz	Output	125MHz Clock Output.
2	VDD	Power	Connect to +3.3V.
3	AGND	Power	Connect to ground.
4	XIN	Input	Crystal connection or external reference frequency input. It can be connected to a 25MHz Fundamental mode crystal.
5	XOUT	Output	Connection to crystal. If using an external reference clock, this pin must be left unconnected.
6	REFOUT	Output	25MHz Reference Clock output.
7	125MHz	Output	125MHz Clock Output.
8	125MHz	Output	125MHz Clock Output.
9	127MHz	Output	127MHz Clock Output.
10	125MHz	Output	125MHz Clock Output.
11	GND	Power	Connect to ground.
12	NC		No connection.
13	NC		No connection.
14	AVDD	Power	Connect to +3.3V.
15	NC		No connection.
16	SHUTDOWNB	Input	Output Enable bit. When this pin is made HIGH, all clocks are enabled. Tri-states all clocks when this pin is LOW.

## Absolute Maximum Ratings

Symbol	Parameter	Rating	Unit
VDD	Power Supply Voltage relative to Ground	-0.5 to +4.6	V
V <sub>IN</sub>	Input Voltage relative to Ground (Input Pins)	-0.5 to VDD+0.3	
T <sub>STG</sub>	Storage temperature	-65 to +150	°C
T <sub>s</sub>	Max. Soldering Temperature (10 sec)	260	°C
T <sub>J</sub>	Junction Temperature	125	°C
T <sub>DV</sub>	Static Discharge Voltage (As per JEDEC STD22- A114-B)	2	KV

Note: These are stress ratings only and are not implied for functional use. Exposure to absolute maximum ratings for prolonged periods of time may affect device reliability.

## Operating Conditions

Parameter	Description	Min	Typ	Max	Unit
VDD / AVDD	Operating Voltage	3.135	3.3	3.465	V
T <sub>A</sub>	Operating Temperature (Ambient Temperature)	0		70	°C
C <sub>L</sub>	Load Capacitance			15	pF
C <sub>IN</sub>	Input Capacitance		5		pF

## DC Electrical Characteristics

Symbol	Parameter	Conditions	Min	Typ	Max	Units
VDD / AVDD	Operating Voltage		3.135	3.3	3.465	V
V <sub>IH</sub>	Input High Voltage		2.2		VDD+0.3	V
V <sub>IL</sub>	Input Low Voltage		GND-0.3		1.0	V
I <sub>IH</sub>	Input HIGH current	V <sub>IN</sub> = VDD			30	μA
I <sub>IL</sub>	Input LOW current	V <sub>IN</sub> = GND			50	μA
V <sub>OH</sub>	Output High Voltage	VDD = 3.135, I <sub>OH</sub> = -12mA	2.4			V
V <sub>OL</sub>	Output Low Voltage	VDD = 3.135, I <sub>OL</sub> = 12mA			0.4	V
I <sub>OZ</sub>	Output Leakage Current	Three-state outputs			10	μA
I <sub>CC</sub>	Static Current	CLKIN and SHUTDOWNB Pins pulled low			5.5	mA
I <sub>DD</sub>	Dynamic Current	No Load, All Clocks on		35		mA
Z <sub>OUT</sub>	Nominal output impedance			30		Ω

**AC Electrical Characteristics**

Symbol	Parameter	Min	Typ	Max	Unit
CLKIN / XIN	Input Frequency		25		MHz
CLK OUT	Output Frequency	Pin 6	25		MHz
		Pin 1,7,8,10	125		
		Pin 9	127		
$t_{LH}^1$	Rising edge slew rate (Measured from 20% to 80%)	1.1	1.7		V/nS
$t_{HL}^1$	Falling edge slew rate (Measured from 80% to 20%)	1.3	2		V/nS
$T_{PJ}^1$	Peak-to-peak Period Jitter @ VDD/2		300		pS
	Synthesis Error (Output Frequency)		0		ppm
$t_D^1$	Output Duty Cycle @ VDD/2	45	50	55	%
$t_{LOCK}$	PLL Lock Time from Power-Up			3	mS

NOTE: 1. CL= 15pF for outputs < 100MHz; CL = 10pF for outputs > 100MHz;

**Typical Crystal Specifications**

Fundamental AT cut parallel resonant crystal	
Nominal frequency	25MHz
Frequency tolerance	± 50 ppm or better at 25°C
Operating temperature range	-25°C to +85°C
Storage temperature	-40°C to +85°C
Load capacitance( $C_P$ )	18pF
Shunt capacitance	7pF maximum
ESR	25 Ω

Note: Note:  $C_L$  is Load Capacitance and  $R_x$  is used to prevent oscillations at overtone frequency of the Fundamental frequency.

**Typical Crystal Interface Circuit**

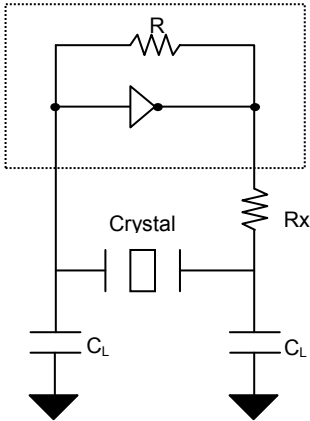

$C_L = 2 * (C_P - C_S)$ ,  
 Where  $C_P$  = Load capacitance of crystal  
 $C_S$  = Stray capacitance due to  $C_{IN}$ , PCB, Trace etc.

Package Information

16-lead Thin Shrunk Small Outline Package (4.40-MM Body)

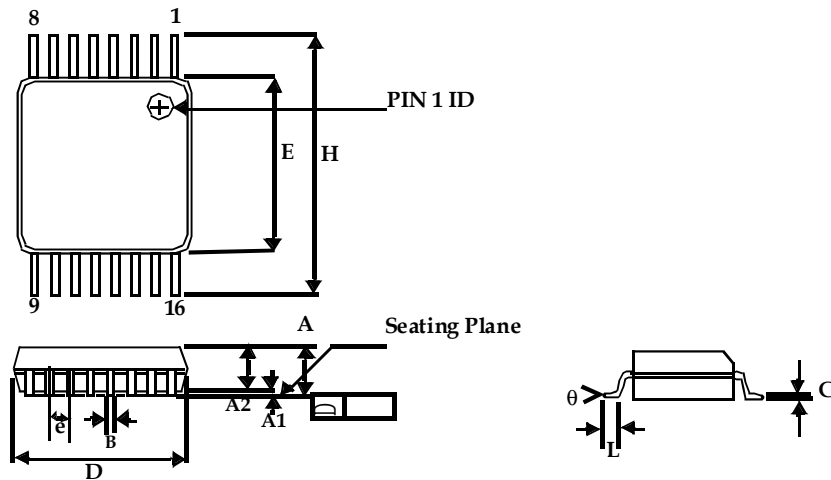

Symbol	Dimensions			
	Inches		Millimeters	
	Min	Max	Min	Max
A		0.043		1.20
A1	0.002	0.006	0.05	0.15
A2	0.031	0.041	0.80	1.05
B	0.007	0.012	0.19	0.30
C	0.004	0.008	0.09	0.20
D	0.193	0.201	4.90	5.10
E	0.169	0.177	4.30	4.50
e	0.026 BSC		0.65 BSC	
H	0.252 BSC		6.40 BSC	
L	0.020	0.030	0.50	0.75
θ	0°	8°	0°	8°

# PCS1P2860A

## Ordering Information

Part Number	Marking	Package	Temperature
PCS1P2860AG-16TR	1P28 60A	16-Pin TSSOP, TAPE & REEL, Green	0°C to +70°C

A "microdot" placed at the end of last row of marking or just below the last row toward the center of package indicates Pb-free.

**ON Semiconductor** and  are registered trademarks of Semiconductor Components Industries, LLC (SCILLC). SCILLC reserves the right to make changes without further notice to any products herein. SCILLC makes no warranty, representation or guarantee regarding the suitability of its products for any particular purpose, nor does SCILLC assume any liability arising out of the application or use of any product or circuit, and specifically disclaims any and all liability, including without limitation special, consequential or incidental damages. "Typical" parameters which may be provided in SCILLC data sheets and/or specifications can and do vary in different applications and actual performance may vary over time. All operating parameters, including "Typicals" must be validated for each customer application by customer's technical experts. SCILLC does not convey any license under its patent rights nor the rights of others. SCILLC products are not designed, intended, or authorized for use as components in systems intended for surgical implant into the body, or other applications intended to support or sustain life, or for any other application in which the failure of the SCILLC product could create a situation where personal injury or death may occur. Should Buyer purchase or use SCILLC products for any such unintended or unauthorized application, Buyer shall indemnify and hold SCILLC and its officers, employees, subsidiaries, affiliates, and distributors harmless against all claims, costs, damages, and expenses, and reasonable attorney fees arising out of, directly or indirectly, any claim of personal injury or death associated with such unintended or unauthorized use, even if such claim alleges that SCILLC was negligent regarding the design or manufacture of the part. SCILLC is an Equal Opportunity/Affirmative Action Employer. U.S. Patent Pending; Timing-Safe and Active Bead are trademarks of PulseCore Semiconductor, a wholly owned subsidiary of ON Semiconductor. This literature is subject to all applicable copyright laws and is not for resale in any manner.

## PUBLICATION ORDERING INFORMATION

### LITERATURE FULFILLMENT:

Literature Distribution Center for ON Semiconductor  
P.O. Box 5163, Denver, Colorado 80217 USA  
**Phone:** 303-675-2175 or 800-344-3860 Toll Free  
USA/Canada  
**Fax:** 303-675-2176 or 800-344-3867 Toll Free  
USA/Canada  
**Email:** [orderlit@onsemi.com](mailto:orderlit@onsemi.com)

**N. American Technical Support:** 800-282-9855  
Toll Free USA/Canada  
**Europe, Middle East and Africa Technical Support:**  
Phone: 421 33 790 2910  
**Japan Customer Focus Center**  
Phone: 81-3-5773-3850

**ON Semiconductor Website:**  
[www.onsemi.com](http://www.onsemi.com)

**Order Literature:** <http://www.onsemi.com/orderlit>

For additional information, please contact your local Sales Representative