



Chipsmall Limited consists of a professional team with an average of over 10 year of expertise in the distribution of electronic components. Based in Hongkong, we have already established firm and mutual-benefit business relationships with customers from,Europe,America and south Asia,supplying obsolete and hard-to-find components to meet their specific needs.

With the principle of "Quality Parts,Customers Priority,Honest Operation,and Considerate Service",our business mainly focus on the distribution of electronic components. Line cards we deal with include Microchip,ALPS,ROHM,Xilinx,Pulse,ON,Everlight and Freescale. Main products comprise IC,Modules,Potentiometer,IC Socket,Relay,Connector.Our parts cover such applications as commercial,industrial, and automotives areas.

We are looking forward to setting up business relationship with you and hope to provide you with the best service and solution. Let us make a better world for our industry!



Contact us

Tel: +86-755-8981 8866 Fax: +86-755-8427 6832

Email & Skype: info@chipsmall.com Web: www.chipsmall.com

Address: A1208, Overseas Decoration Building, #122 Zhenhua RD., Futian, Shenzhen, China





PD55008L-E

RF POWER transistor, LDMOST plastic family
N-Channel enhancement-mode lateral MOSFETs

General features

- Excellent thermal stability
- Common source configuration
- $P_{OUT} = 8W$ with 17dB gain @ 500MHz / 12.5V
- Integrated ESD protection
- New leadless plastic package
- Supplied in tape and reel of 3K units
- In compliance with 2002/95/EC european directive

Description

The PD55008L-E is a common source N-channel, enhancement-mode lateral Field-Effect RF power transistor. It is designed for high gain, broad band commercial and industrial applications. It operates at 12V in common source mode at frequencies up to 1GHz.

PD55008L-E boasts the excellent gain, linearity and reliability of STH1LV latest LDMOS technology mounted in the innovative leadless SMD plastic package, PowerFLAT™. PD55008L-E's superior linearity performance makes it an ideal solution for car mobile radio.

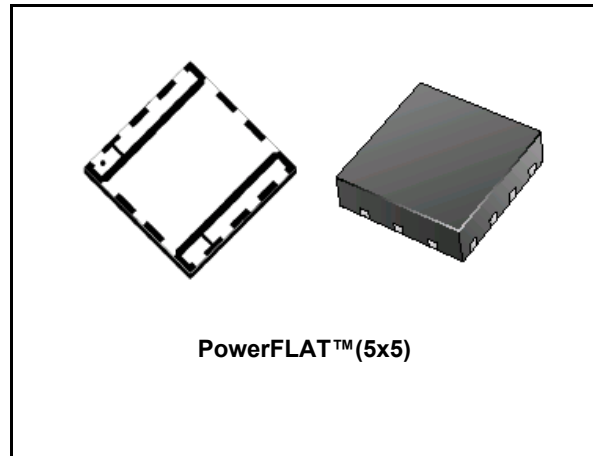

Pin connection

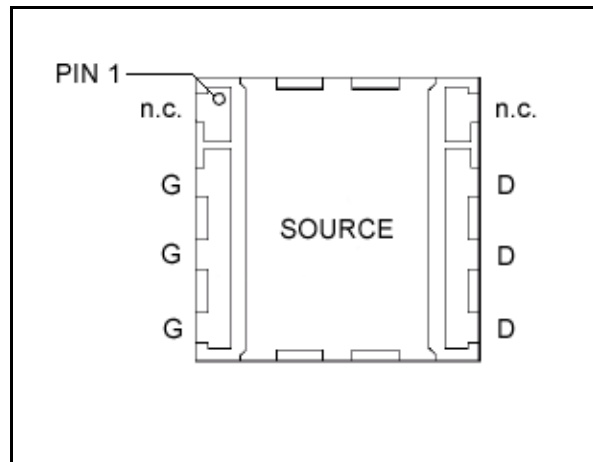

Order codes

Part number	Marking	Package	Packaging
PD55008L-E	55008	PowerFLAT™(5x5)	Tape and reel

Contents

- 1 Electrical data 3**
 - 1.1 Maximum ratings 3
 - 1.2 Thermal data 3

- 2 Electrical characteristics 4**
 - 2.1 Static 4
 - 2.2 Dynamic 4
 - 2.3 Esd protection characteristics 4
 - 2.4 Moisture sensitivity level 4

- 3 Typical performance 5**

- 4 Common source s-parameter 7**
 - 4.1 PD55008L (VDS = 12.5V IDS = 0.15A) 7
 - 4.2 PD55008L (VDS = 12.5V IDS = 0.8A) 8
 - 4.3 PD55008L (VDS = 12.5V IDS = 1.5A) 9

- 5 Mechanical Data 10**

- 6 Revision history 14**

1 Electrical data

1.1 Maximum ratings

Table 1. Absolute maximum ratings ($T_{CASE} = 25^{\circ}C$)

Symbol	Parameter	Value	Unit
$V_{(BR)DSS}$	Drain-source voltage	40	V
V_{GS}	Gate-source voltage	-0.5 to +15	V
I_D	Drain current	5	A
P_{DISS}	Power dissipation (@ $T_C = 70^{\circ}C$)	19.5	W
T_J	Max. operating junction temperature	150	$^{\circ}C$
T_{STG}	Storage temperature	-65 to +150	$^{\circ}C$

1.2 Thermal data

Table 2. Thermal data

Symbol	Parameter	Value	Unit
R_{thJC}	Junction - case thermal resistance	4.1	$^{\circ}C/W$

2 Electrical characteristics

(T_{CASE} = +25 °C)

2.1 Static

Table 3. Static

Symbol	Test conditions	Min.	Typ.	Max.	Unit
I _{DSS}	V _{GS} = 0 V V _{DS} = 28 V			1	μA
I _{GSS}	V _{GS} = 5V V _{DS} = 0 V			1	μA
V _{GS(Q)}	V _{DS} = 10 V I _D = 150 mA	2.0		5.0	V
V _{DS(ON)}	V _{GS} = 10 V I _D = 0.5 A		0.13	0.14	V
G _{FS}	V _{DS} = 10 V I _D = 1.5 A		1.6		mho
C _{ISS}	V _{GS} = 0 V V _{DS} = 12.5 V f = 1 MHz		53		pF
C _{OSS}	V _{GS} = 0 V V _{DS} = 12.5 V f = 1 MHz		38		pF
C _{RSS}	V _{GS} = 0 V V _{DS} = 12.5 V f = 1 MHz		3.2		pF

2.2 Dynamic

Table 4. Dynamic

Symbol	Test conditions	Min.	Typ.	Max.	Unit
P _{OUT}	V _{DD} = 12.5V, I _{DQ} = 150mA f = 500MHz	8			W
G _P	V _{DD} = 12.5V, I _{DQ} = 150mA, P _{OUT} = 8W, f = 500MHz	17	19		dB
h _D	V _{DD} = 12.5V, I _{DQ} = 150mA, P _{OUT} = 8W, f = 500MHz	55	63		%
Load mismatch	V _{DD} = 15.5V, I _{DQ} = 150mA, P _{OUT} = 8W, f = 500MHz All phase angles	20:1			VSWR

2.3 ESD protection characteristics

Table 5. ESD protection

Test conditions	Class
Human Body Model	2
Machine Model	M3

2.4 Moisture sensitivity level

Table 6. Moisture sensitivity level

Test methodology	Rating
J-STD-020B	MSL 3

3 Typical performance

Figure 1. Capacitance vs. supply voltage

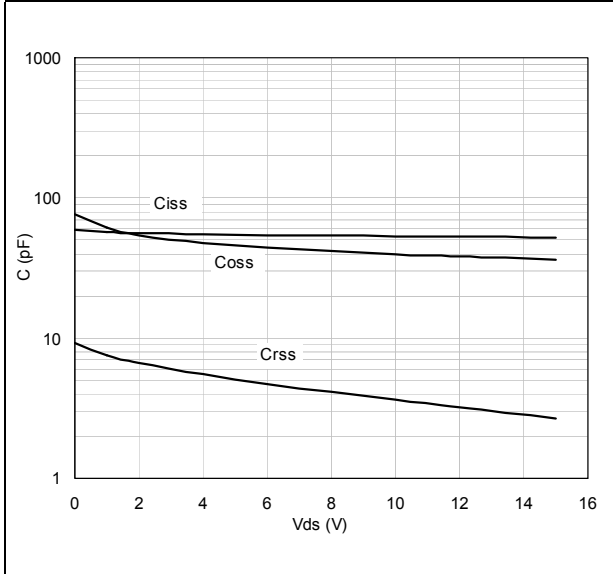

Figure 2. Output power vs. input power

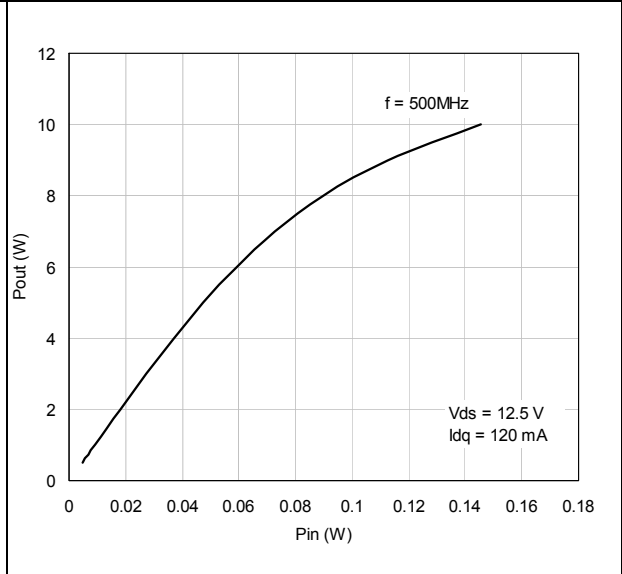

Figure 3. Power gain vs output power

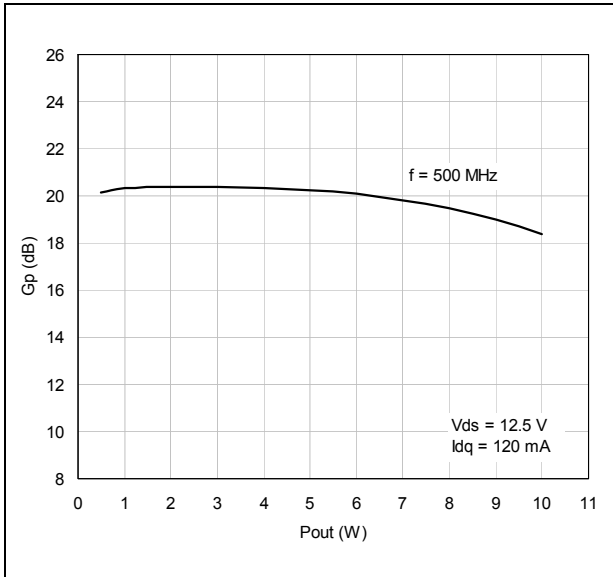

Figure 4. Efficiency vs. output power

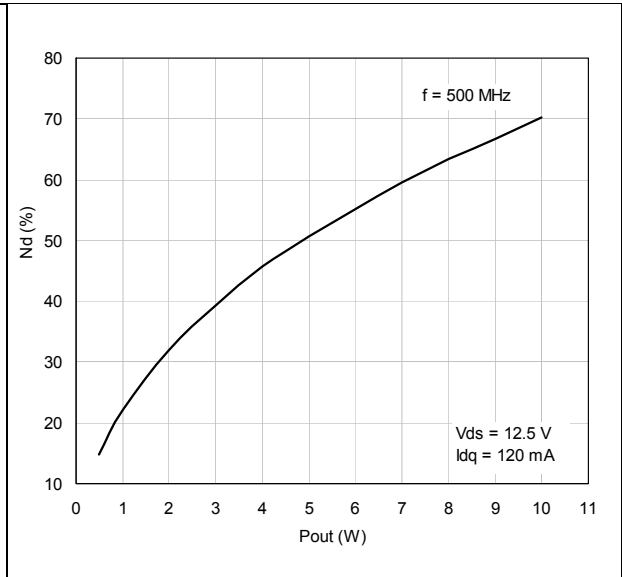
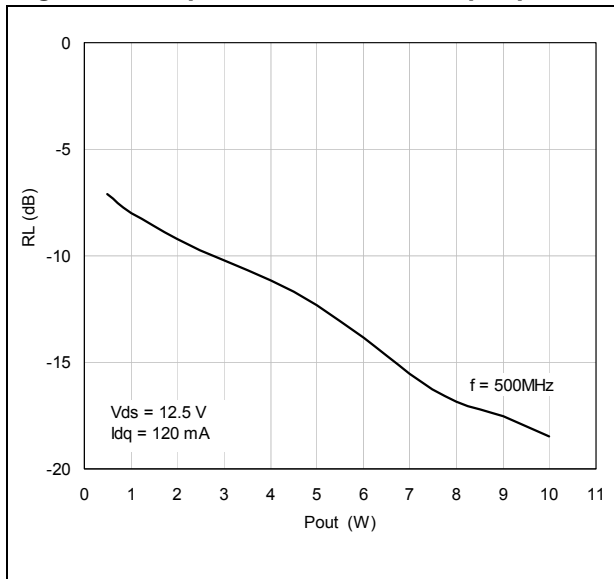

Figure 5. Input return loss vs. output power



4 Common source s-parameter

4.1 PD55008L ($V_{DS} = 12.5V$ $I_{DS} = 0.15A$)

Table 7. S-parameter

Freq (MHz)	$ S_{11} $	$S_{11}\angle\Phi$	$ S_{21} $	$S_{21}\angle\Phi$	$ S_{12} $	$S_{12}\angle\Phi$	$ S_{22} $	$S_{22}\angle\Phi$
50	0.783	-134	16.75	100	0.034	11	0.654	-135
100	0.774	-153	8.73	82	0.034	-6	0.667	-150
150	0.791	-159	5.61	70	0.033	-15	0.698	-155
200	0.814	-163	4.00	61	0.029	-22	0.737	-157
250	0.838	-165	3.00	54	0.027	-28	0.775	-159
300	0.862	-166	2.34	47	0.023	-32	0.806	-161
350	0.879	-168	1.87	41	0.021	-35	0.837	-163
400	0.894	-169	1.52	37	0.018	-37	0.861	-164
450	0.908	-171	1.26	32	0.015	-37	0.881	-166
500	0.919	-172	1.06	28	0.013	-37	0.900	-167
550	0.927	-173	0.91	25	0.010	-36	0.911	-168
600	0.937	-174	0.78	22	0.009	-33	0.917	-169
650	0.942	-175	0.68	19	0.007	-20	0.931	-170
700	0.945	-176	0.60	16	0.005	-7	0.938	-171
750	0.948	-177	0.53	14	0.005	14	0.940	-172
800	0.953	-178	0.47	12	0.006	36	0.950	-173
850	0.956	-179	0.42	10	0.007	48	0.954	-173
900	0.956	-179	0.38	9	0.007	60	0.957	-174
950	0.957	180	0.34	7	0.009	66	0.960	-175
1000	0.957	179	0.31	6	0.010	71	0.960	-176
1050	0.958	178	0.28	4	0.012	73	0.960	-176
1100	0.959	177	0.26	3	0.013	75	0.967	-177
1150	0.960	177	0.24	2	0.014	73	0.967	-177
1200	0.959	176	0.22	1	0.015	79	0.966	-178
1250	0.958	176	0.20	0	0.017	78	0.970	-178
1300	0.957	175	0.19	-1	0.019	78	0.970	-179
1350	0.956	174	0.18	-2	0.020	78	0.971	-180
1400	0.954	174	0.16	-3	0.020	80	0.971	-180
1450	0.952	173	0.15	-4	0.022	80	0.968	180
1500	0.951	173	0.14	-5	0.023	81	0.970	179

4.2 PD55008L ($V_{DS} = 12.5V$ $I_{DS} = 0.8A$)

Table 8. S-parameter

Freq (MHz)	$ S_{11} $	$\angle S_{11}$	$ S_{21} $	$\angle S_{21}$	$ S_{12} $	$\angle S_{12}$	$ S_{22} $	$\angle S_{22}$
50	0.828	-147	19.60	97	0.023	11	0.691	-154
100	0.822	-162	10.11	84	0.023	-1	0.714	-164
150	0.829	-167	6.61	75	0.022	-7	0.729	-166
200	0.839	-169	4.82	68	0.021	-11	0.749	-167
250	0.852	-170	3.71	62	0.019	-16	0.772	-167
300	0.866	-171	2.97	56	0.017	-17	0.793	-168
350	0.877	-172	2.43	51	0.015	-18	0.815	-168
400	0.887	-173	2.02	46	0.014	-18	0.833	-169
450	0.898	-174	1.71	42	0.012	-16	0.852	-169
500	0.907	-175	1.47	38	0.010	-12	0.871	-170
550	0.916	-175	1.27	34	0.009	-10	0.879	-170
600	0.923	-176	1.10	31	0.008	1	0.887	-172
650	0.929	-177	0.98	27	0.007	12	0.904	-172
700	0.931	-178	0.86	25	0.007	23	0.911	-173
750	0.937	-179	0.77	22	0.008	37	0.916	-173
800	0.942	-179	0.69	20	0.008	44	0.928	-174
850	0.948	-180	0.62	17	0.009	53	0.933	-174
900	0.946	180	0.56	15	0.010	61	0.936	-175
950	0.948	179	0.51	13	0.011	65	0.940	-176
1000	0.950	178	0.47	12	0.012	67	0.943	-176
1050	0.950	178	0.43	10	0.013	71	0.945	-177
1100	0.953	177	0.39	8	0.016	71	0.951	-177
1150	0.953	176	0.36	7	0.016	72	0.951	-178
1200	0.953	176	0.34	5	0.017	75	0.953	-178
1250	0.952	175	0.31	4	0.019	75	0.958	-179
1300	0.952	175	0.29	3	0.021	75	0.958	-179
1350	0.951	174	0.27	1	0.022	75	0.960	-180
1400	0.951	174	0.25	0	0.023	76	0.960	180
1450	0.949	173	0.23	0	0.024	76	0.959	180
1500	0.950	173	0.21	0	0.025	75	0.960	179

4.3 PD55008L ($V_{DS} = 12.5V$ $I_{DS} = 1.5A$)

Table 9. S-parameter

Freq (MHz)	$ S_{11} $	$S_{11}\angle\Phi$	$ S_{21} $	$S_{21}\angle\Phi$	$ S_{12} $	$S_{12}\angle\Phi$	$ S_{22} $	$S_{22}\angle\Phi$
50	0.835	-145	18.15	98	0.023	11	0.681	-156
100	0.831	-161	9.38	84	0.023	-1	0.711	-164
150	0.837	-166	6.14	75	0.022	-7	0.729	-166
200	0.847	-169	4.47	68	0.020	-11	0.751	-167
250	0.858	-170	3.44	61	0.019	-15	0.773	-168
300	0.872	-171	2.74	55	0.017	-17	0.794	-168
350	0.882	-172	2.24	50	0.015	-17	0.819	-168
400	0.893	-173	1.87	46	0.014	-18	0.837	-169
450	0.904	-174	1.58	41	0.012	-16	0.855	-170
500	0.913	-175	1.35	37	0.010	-13	0.875	-170
550	0.920	-176	1.17	33	0.009	-5	0.881	-170
600	0.927	-177	1.02	30	0.008	1	0.890	-172
650	0.931	-177	0.89	27	0.007	13	0.905	-172
700	0.935	-178	0.79	24	0.007	28	0.914	-173
750	0.940	-179	0.70	22	0.008	41	0.919	-173
800	0.944	-180	0.63	19	0.008	48	0.930	-174
850	0.948	180	0.57	17	0.009	55	0.934	-175
900	0.948	179	0.51	15	0.010	61	0.936	-175
950	0.947	179	0.47	13	0.011	65	0.943	-176
1000	0.949	178	0.43	11	0.013	66	0.943	-176
1050	0.949	177	0.39	10	0.014	70	0.947	-177
1100	0.951	177	0.36	8	0.015	72	0.953	-177
1150	0.951	176	0.33	7	0.016	72	0.955	-178
1200	0.952	176	0.30	5	0.018	74	0.957	-178
1250	0.951	175	0.28	4	0.019	73	0.960	-179
1300	0.950	174	0.26	3	0.021	75	0.959	-179
1350	0.951	174	0.24	2	0.021	75	0.961	-180
1400	0.950	173	0.22	1	0.023	76	0.962	-180
1450	0.948	173	0.21	1	0.024	76	0.960	180
1500	0.949	172	0.20	1	0.025	75	0.963	179

5 Mechanical data

In order to meet environmental requirements, ST offers these devices in ECOPACK® packages. These packages have a Lead-free second level interconnect . The category of second level interconnect is marked on the package and on the inner box label, in compliance with JEDEC Standard JESD97. The maximum ratings related to soldering conditions are also marked on the inner box label. ECOPACK is an ST trademark. ECOPACK specifications are available at: www.st.com

Table 10. PowerFLAT™ Mechanical data

Dim.	mm.			Inch		
	Min.	Typ.	Max.	Min.	Typ.	Max.
A		0.90	1.00		0.035	0.039
A1		0.02	0.05		0.001	0.002
A3		0.24			0.009	
AA	0.15	0.25	0.35	0.006	0.01	0.014
b	0.43	0.51	0.58	0.017	0.020	0.023
c	0.64	0.71	0.79	0.025	0.028	0.031
D		5.00			0.197	
d		0.30			0.011	
E		5.00			0.197	
E2	2.49	2.57	2.64	0.098	0.101	0.104
e		1.27			0.050	
f		3.37			0.132	
g		0.74			0.03	
h		0.21			0.008	

Figure 6. Package dimensions

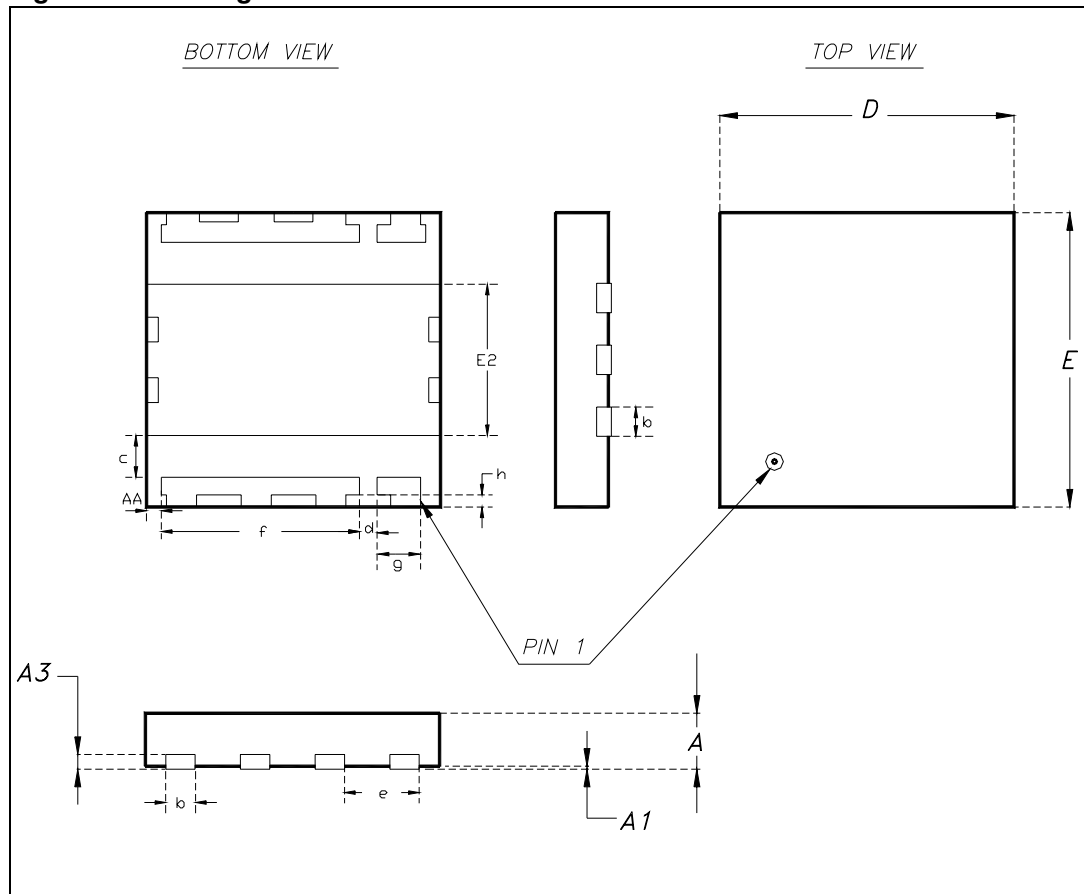

Figure 7. Recommended footprint

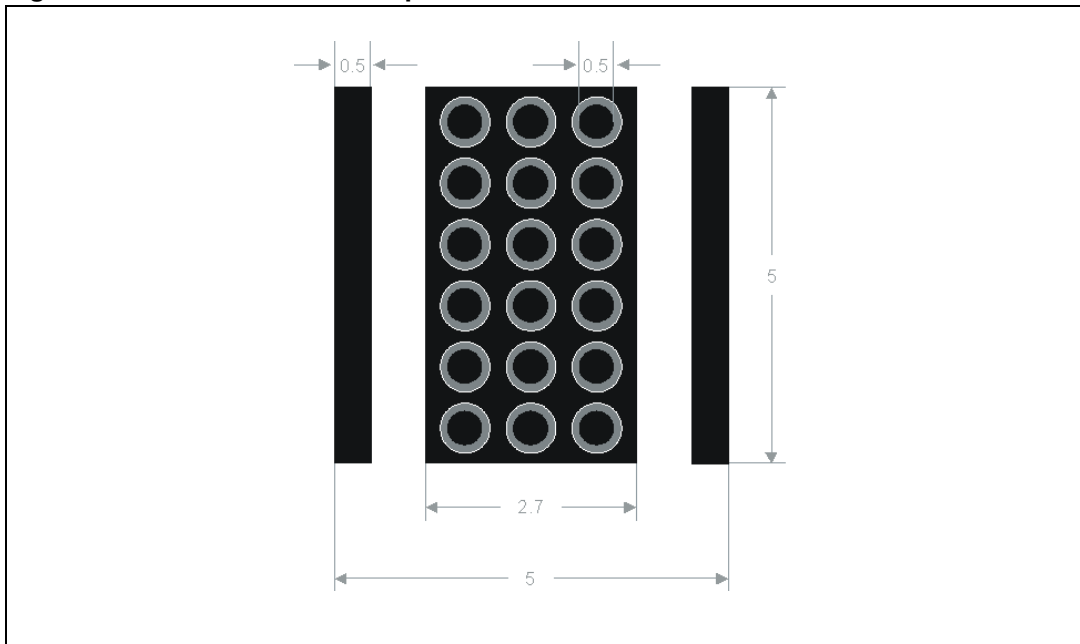
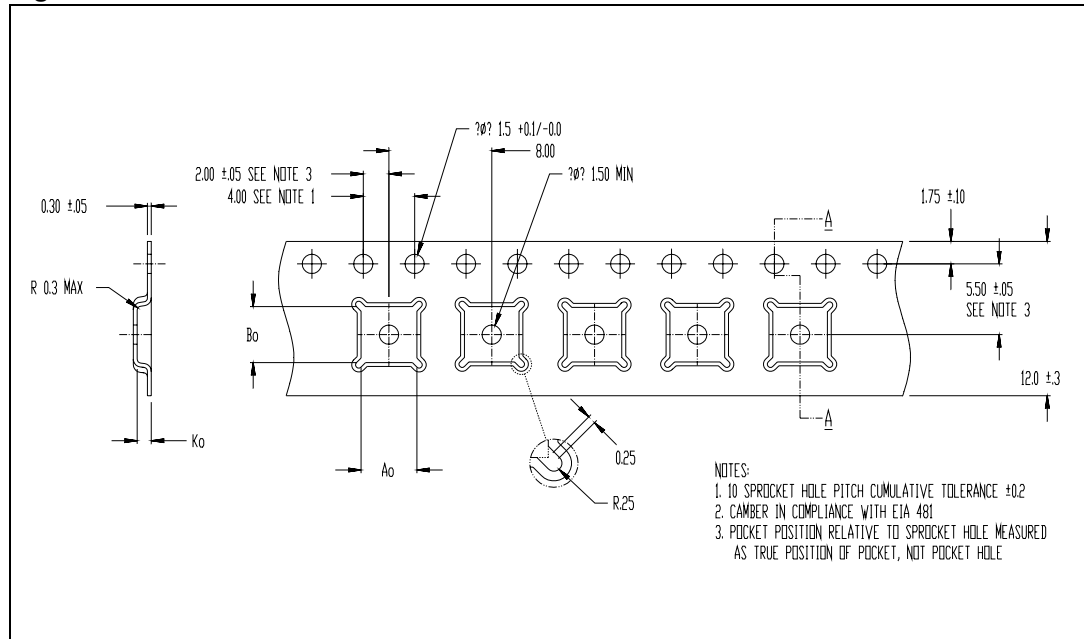

Table 11. Tape and reel dimensions

Dim.	mm		
	Min.	Typ.	Max
Ao	5.15	5.25	5.35
Bo	5.15	5.25	5.35
Ko	1.0	1.1	1.2

Figure 8. Reel information



6 Revision history

Table 12. Revision history

Date	Revision	Changes
12-Apr-2006	1	Initial release.
16-Jan-2007	2	Typo in S paramiters

Please Read Carefully:

Information in this document is provided solely in connection with ST products. STMicroelectronics NV and its subsidiaries ("ST") reserve the right to make changes, corrections, modifications or improvements, to this document, and the products and services described herein at any time, without notice.

All ST products are sold pursuant to ST's terms and conditions of sale.

Purchasers are solely responsible for the choice, selection and use of the ST products and services described herein, and ST assumes no liability whatsoever relating to the choice, selection or use of the ST products and services described herein.

No license, express or implied, by estoppel or otherwise, to any intellectual property rights is granted under this document. If any part of this document refers to any third party products or services it shall not be deemed a license grant by ST for the use of such third party products or services, or any intellectual property contained therein or considered as a warranty covering the use in any manner whatsoever of such third party products or services or any intellectual property contained therein.

UNLESS OTHERWISE SET FORTH IN ST'S TERMS AND CONDITIONS OF SALE ST DISCLAIMS ANY EXPRESS OR IMPLIED WARRANTY WITH RESPECT TO THE USE AND/OR SALE OF ST PRODUCTS INCLUDING WITHOUT LIMITATION IMPLIED WARRANTIES OF MERCHANTABILITY, FITNESS FOR A PARTICULAR PURPOSE (AND THEIR EQUIVALENTS UNDER THE LAWS OF ANY JURISDICTION), OR INFRINGEMENT OF ANY PATENT, COPYRIGHT OR OTHER INTELLECTUAL PROPERTY RIGHT.

UNLESS EXPRESSLY APPROVED IN WRITING BY AN AUTHORIZED ST REPRESENTATIVE, ST PRODUCTS ARE NOT RECOMMENDED, AUTHORIZED OR WARRANTED FOR USE IN MILITARY, AIR CRAFT, SPACE, LIFE SAVING, OR LIFE SUSTAINING APPLICATIONS, NOR IN PRODUCTS OR SYSTEMS WHERE FAILURE OR MALFUNCTION MAY RESULT IN PERSONAL INJURY, DEATH, OR SEVERE PROPERTY OR ENVIRONMENTAL DAMAGE. ST PRODUCTS WHICH ARE NOT SPECIFIED AS "AUTOMOTIVE GRADE" MAY ONLY BE USED IN AUTOMOTIVE APPLICATIONS AT USER'S OWN RISK.

Resale of ST products with provisions different from the statements and/or technical features set forth in this document shall immediately void any warranty granted by ST for the ST product or service described herein and shall not create or extend in any manner whatsoever, any liability of ST.

ST and the ST logo are trademarks or registered trademarks of ST in various countries.

Information in this document supersedes and replaces all information previously supplied.

The ST logo is a registered trademark of STMicroelectronics. All other names are the property of their respective owners.

© 2007 STMicroelectronics - All rights reserved

STMicroelectronics group of companies

Australia - Belgium - Brazil - Canada - China - Czech Republic - Finland - France - Germany - Hong Kong - India - Israel - Italy - Japan - Malaysia - Malta - Morocco - Singapore - Spain - Sweden - Switzerland - United Kingdom - United States of America

www.st.com

