



Chipsmall Limited consists of a professional team with an average of over 10 year of expertise in the distribution of electronic components. Based in Hongkong, we have already established firm and mutual-benefit business relationships with customers from,Europe,America and south Asia,supplying obsolete and hard-to-find components to meet their specific needs.

With the principle of “Quality Parts,Customers Priority,Honest Operation,and Considerate Service”,our business mainly focus on the distribution of electronic components. Line cards we deal with include Microchip,ALPS,ROHM,Xilinx,Pulse,ON,Everlight and Freescale. Main products comprise IC,Modules,Potentiometer,IC Socket,Relay,Connector.Our parts cover such applications as commercial,industrial, and automotives areas.

We are looking forward to setting up business relationship with you and hope to provide you with the best service and solution. Let us make a better world for our industry!



Contact us

Tel: +86-755-8981 8866 Fax: +86-755-8427 6832

Email & Skype: info@chipsmall.com Web: www.chipsmall.com

Address: A1208, Overseas Decoration Building, #122 Zhenhua RD., Futian, Shenzhen, China





PD57002 PD57002S

RF POWER TRANSISTORS The *LdmoST* Plastic FAMILY

N-CHANNEL ENHANCEMENT-MODE LATERAL MOSFETs

- EXCELLENT THERMAL STABILITY
- COMMON SOURCE CONFIGURATION
- $P_{OUT} = 2\text{ W}$ with 15 dB gain @ 960 MHz / 28 V
- NEW RF PLASTIC PACKAGE

DESCRIPTION

The PD57002 is a common source N-Channel, enhancement-mode lateral Field-Effect RF power transistor designed for broadband commercial and industrial applications at frequencies up to 1000 MHz. The PD57002 is designed for high gain and broadband performance operating in common source mode at 28 V. It is ideal for digital cellular BTS applications requiring high linearity.

The PowerSO-10 plastic package, designed to offer high reliability, is the first ST JEDEC approved, high power SMD package. It has been specially optimized for RF needs and offers excellent RF performances and ease of assembly.

Mounting recommendations are available in www.st.com/rfl (look for application note AN1294)

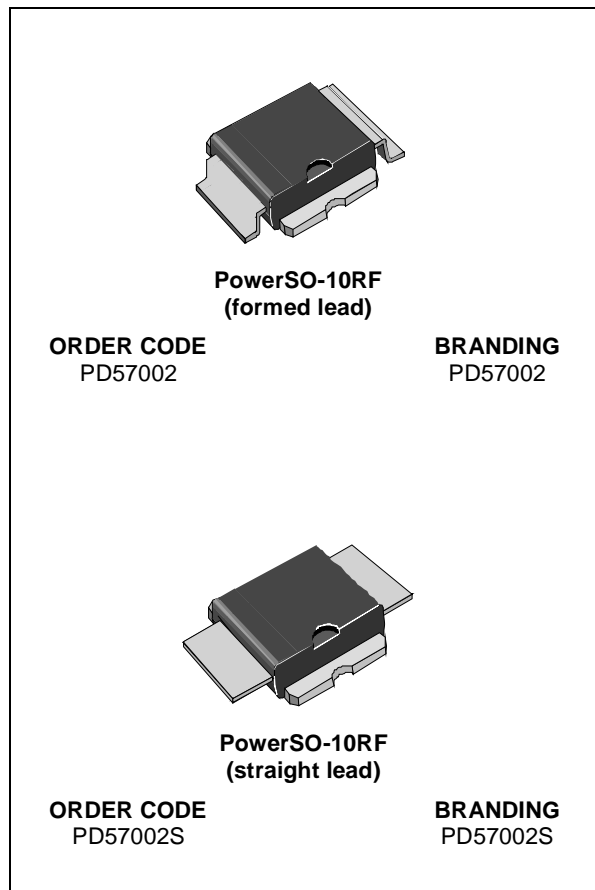

ABSOLUTE MAXIMUM RATINGS ($T_{CASE} = 25^{\circ}\text{C}$)

Symbol	Parameter	Value	Unit
$V_{(BR)DSS}$	Drain-Source Voltage	65	V
V_{GS}	Gate-Source Voltage	± 20	V
I_D	Drain Current	0.25	A
P_{DISS}	Power Dissipation (@ $T_c = 70^{\circ}\text{C}$)	4.75	W
T_j	Max. Operating Junction Temperature	165	$^{\circ}\text{C}$
T_{STG}	Storage Temperature	-65 to +150	$^{\circ}\text{C}$

THERMAL DATA

$R_{th(j-c)}$	Junction -Case Thermal Resistance	20	$^{\circ}\text{C}/\text{W}$
---------------	-----------------------------------	----	-----------------------------

PD57002 - PD57002S

ELECTRICAL SPECIFICATION (T_{CASE} = 25°C)

STATIC

Symbol	Test Conditions		Min.	Typ.	Max.	Unit
I _{DSS}	V _{GS} = 0 V	V _{DS} = 28 V			1	μA
I _{GSS}	V _{GS} = 20 V	V _{DS} = 0 V			1	μA
V _{GS(Q)}	V _{DS} = 28 V	I _D = 10 mA	2.0		5.0	V
V _{DS(ON)}	V _{GS} = 10 V	I _D = 125 mA		0.7	0.9	V
g _{FS}	V _{DS} = 10 V	I _D = 200 mA		--		mho
C _{ISS}	V _{GS} = 0 V	V _{DS} = 28 V		7.1		pF
C _{OSS}	V _{GS} = 0 V	V _{DS} = 28 V		5.8		pF
C _{RSS}	V _{GS} = 0 V	V _{DS} = 28 V		0.1		pF

DYNAMIC

Symbol	Test Conditions				Min.	Typ.	Max.	Unit
P _{1dB}	V _{DD} = 28 V	I _{DQ} = 10 mA		f = 960 MHz	2			W
G _P	V _{DD} = 28 V	I _{DQ} = 10 mA	P _{OUT} = 2 W	f = 960 MHz	15			dB
η _D	V _{DD} = 28 V	I _{DQ} = 10 mA	P _{OUT} = 2 W	f = 960 MHz	45			%
Load mismatch	V _{DD} = 28 V	I _{DQ} = 10 mA	P _{OUT} = 2 W	f = 960 MHz	10:1			VSWR
	ALL PHASE ANGLES							

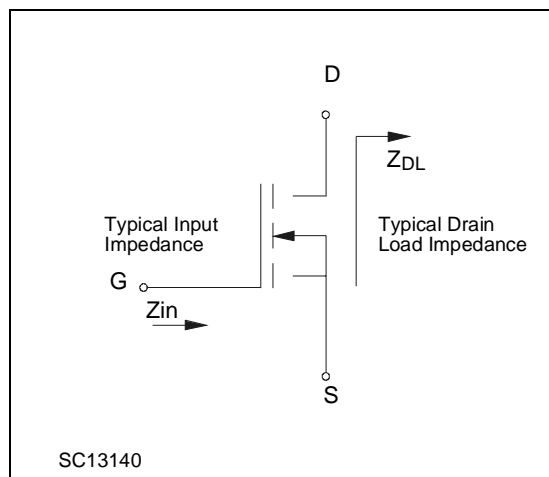
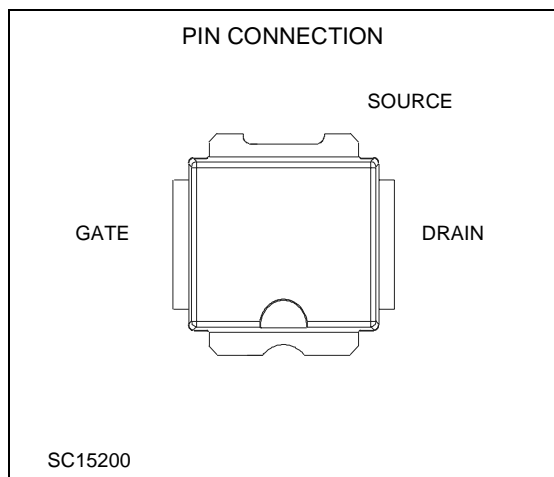

IMPEDANCE DATA

PD57002S

FREQ. MHz	Z _{IN} (Ω)	Z _{DL} (Ω)
925	1.894 - j 13.43	6.445 + j 23.60
945	2.440 - j 12.53	7.245 + j 25.09
960	2.760 - j 12.13	7.715 + j 25.69

TYPICAL PERFORMANCE

Capacitances vs. Drain Voltage

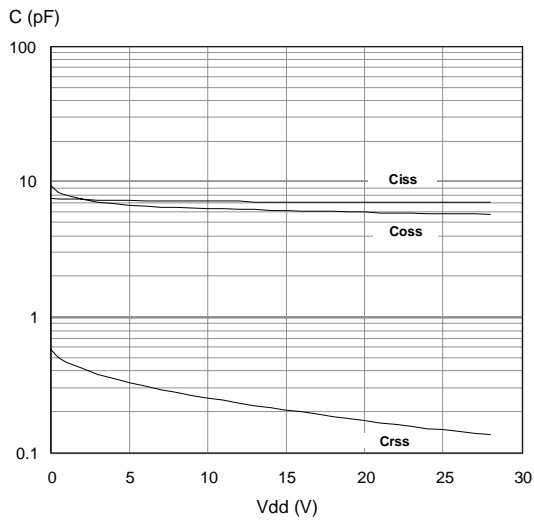

Drain Current vs Gate-Source Voltage

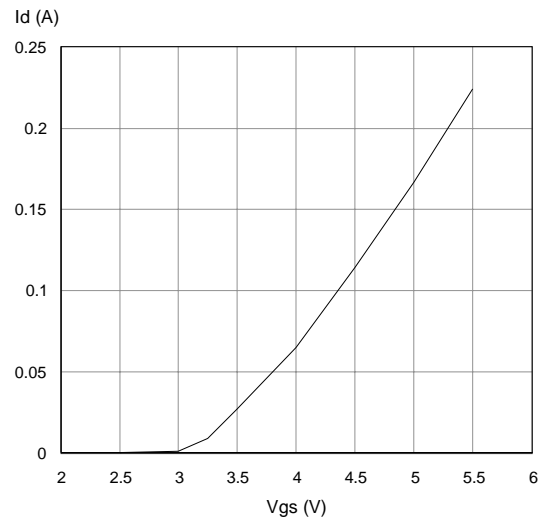

Gate-Source Voltage vs Case Temperature

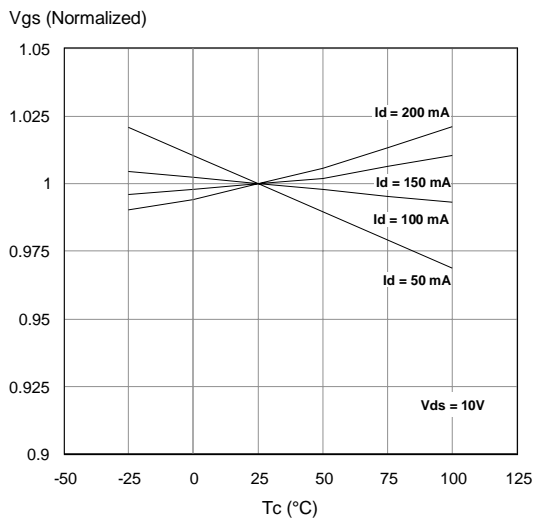

PD57002 - PD57002S

TYPICAL PERFORMANCE (PD57002S)

Output Power vs Input Power

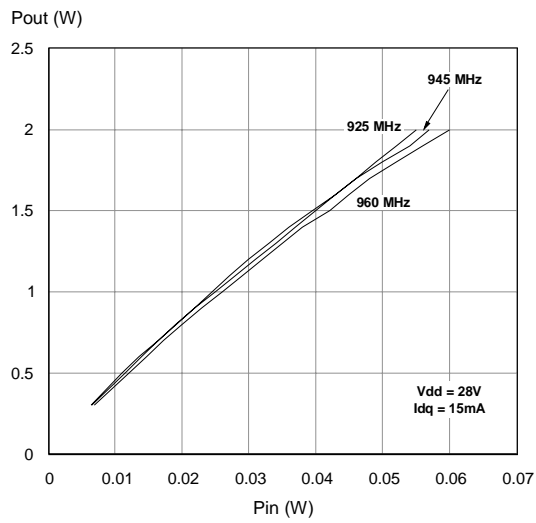

Input Return Loss vs Output Power

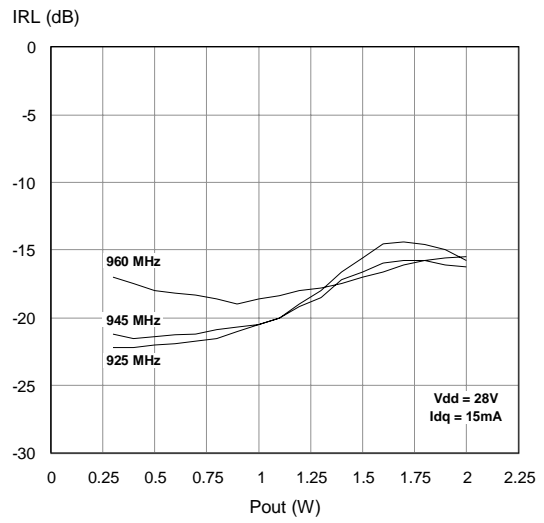

Power Gain vs Output Power

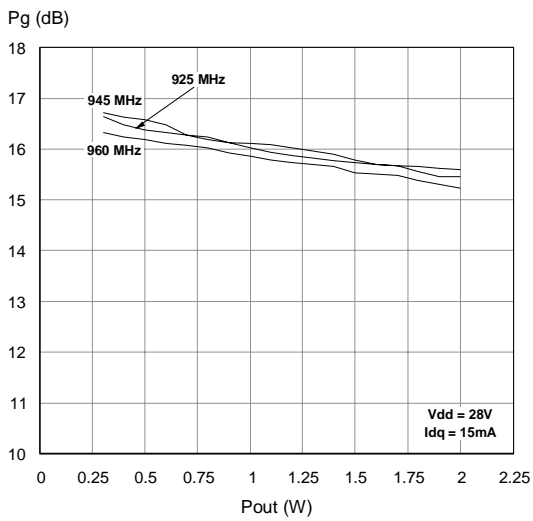

Efficiency vs. Output Power

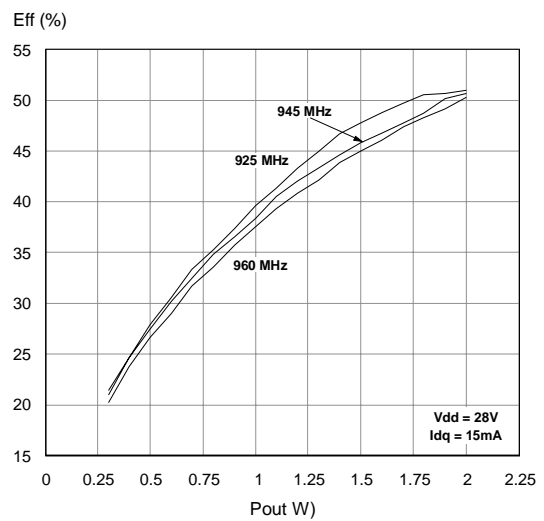

Output Power vs Drain Current

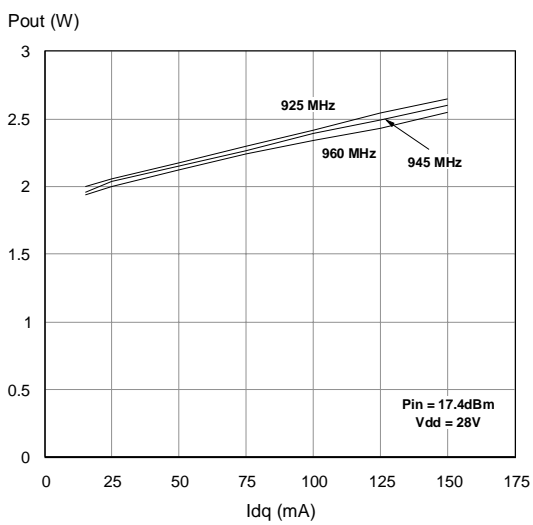

Efficiency vs Drain Current

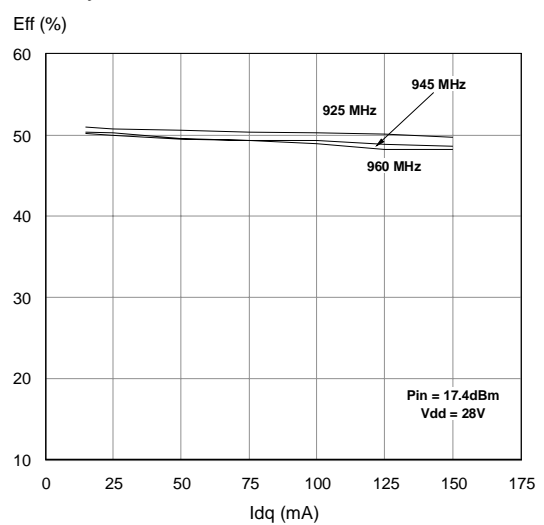

TYPICAL PERFORMANCE (PD57002S)

Output Power vs Drain Voltage

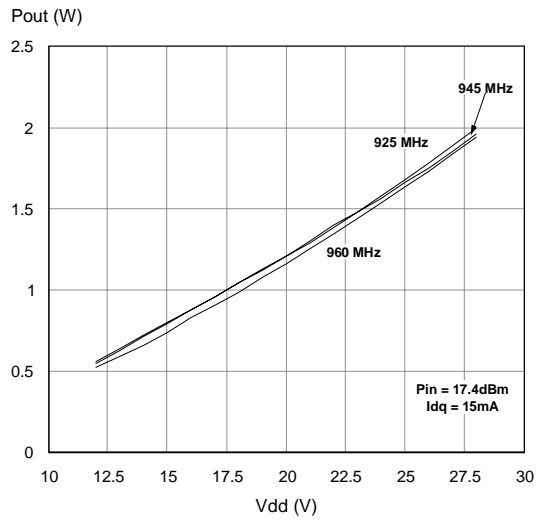

Efficiency vs Drain Voltage

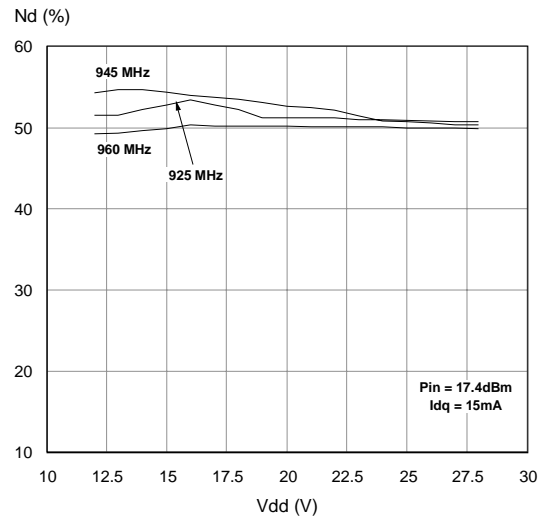

Output Power vs Gate-Source Voltage

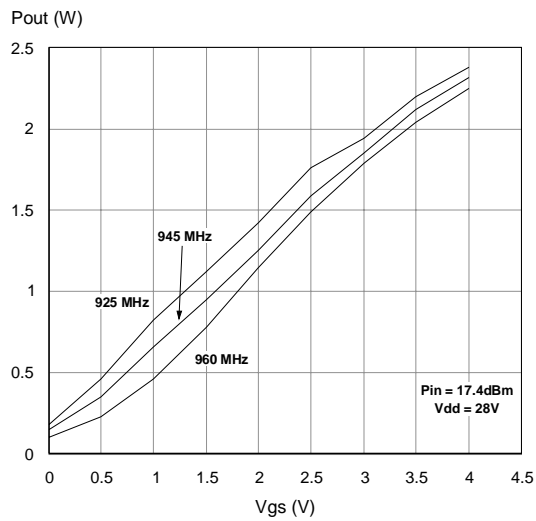

PD57002 - PD57002S**COMMON SOURCE S-PARAMETER (PD57002)** $(V_{DS} = 28V \quad I_{DS} = 75mA)$

FREQ (MHz)	$ S_{11} $	$\angle S_{11}$	$ S_{21} $	$\angle S_{21}$	$ S_{12} $	$\angle S_{12}$	$ S_{22} $	$\angle S_{22}$
50	0.980	-16	10.01	166	0.006	75	0.963	-12
100	0.972	-31	9.63	153	0.012	64	0.949	-23
150	0.966	-46	9.04	141	0.017	53	0.942	-35
200	0.951	-59	8.46	129	0.020	42	0.918	-45
250	0.944	-70	7.78	119	0.023	32	0.911	-54
300	0.936	-80	7.09	110	0.025	23	0.896	-63
350	0.925	-90	6.50	101	0.026	16	0.885	-70
400	0.926	-98	5.93	93	0.026	8	0.888	-77
450	0.924	-105	5.43	85	0.026	2	0.886	-83
500	0.919	-112	4.96	78	0.027	-2	0.897	-89
550	0.921	-117	4.52	72	0.027	-9	0.894	-95
600	0.915	-122	4.17	66	0.026	-15	0.896	-99
650	0.920	-127	3.84	61	0.026	-20	0.904	-104
700	0.922	-131	3.55	56	0.024	-25	0.914	-108
750	0.921	-135	3.31	51	0.024	-29	0.920	-112
800	0.922	-138	3.07	46	0.023	-33	0.929	-116
850	0.924	-141	2.87	42	0.022	-38	0.937	-119
900	0.922	-145	2.69	38	0.021	-39	0.934	-123
950	0.926	-147	2.52	34	0.020	-43	0.931	-125
1000	0.919	-150	2.38	30	0.019	-45	0.938	-128
1050	0.920	-153	2.24	27	0.018	-49	0.941	-131
1100	0.918	-155	2.13	23	0.018	-51	0.941	-134
1150	0.916	-158	2.02	19	0.017	-56	0.943	-136
1200	0.921	-160	1.92	16	0.016	-60	0.940	-138
1250	0.912	-162	1.84	12	0.015	-62	0.943	-141
1300	0.914	-164	1.76	9	0.014	-70	0.944	-143
1350	0.914	-166	1.68	6	0.013	-71	0.942	-144
1400	0.908	-168	1.61	3	0.013	-75	0.947	-146
1450	0.909	-170	1.54	0	0.012	-88	0.940	-148
1500	0.900	-172	1.45	-3	0.011	-108	0.934	-149

COMMON SOURCE S-PARAMETER (PD57002)

($V_{DS} = 28V$ $I_{DS} = 150mA$)

FREQ (MHz)	$ S_{11} $	$\angle S_{11}$	$ S_{21} $	$\angle S_{21}$	$ S_{12} $	$\angle S_{12}$	$ S_{22} $	$\angle S_{22}$
50	0.998	-17	10.95	166	0.006	77	0.960	-12
100	0.989	-32	10.50	153	0.011	63	0.946	-24
150	0.975	-47	9.83	140	0.016	52	0.937	-35
200	0.965	-61	9.15	128	0.020	41	0.912	-45
250	0.954	-72	8.40	118	0.022	31	0.904	-54
300	0.943	-82	7.63	108	0.024	22	0.885	-63
350	0.939	-92	6.98	100	0.025	15	0.876	-70
400	0.934	-100	6.35	92	0.025	7	0.880	-77
450	0.931	-107	5.81	84	0.026	2	0.877	-83
500	0.930	-113	5.30	77	0.026	-3	0.885	-89
550	0.927	-119	4.82	71	0.025	-9	0.886	-95
600	0.925	-124	4.45	65	0.025	-15	0.886	-99
650	0.927	-128	4.09	60	0.025	-21	0.896	-104
700	0.926	-133	3.78	55	0.023	-25	0.906	-108
750	0.930	-136	3.52	50	0.022	-29	0.912	-112
800	0.930	-140	3.27	45	0.021	-33	0.923	-115
850	0.931	-143	3.06	41	0.021	-36	0.929	-119
900	0.930	-146	2.87	36	0.200	-40	0.930	-122
950	0.929	-149	2.68	33	0.019	-42	0.928	-125
1000	0.931	-152	2.53	29	0.018	-46	0.933	-128
1050	0.926	-154	2.38	25	0.017	-48	0.932	-130
1100	0.927	-157	2.27	21	0.016	-54	0.935	-133
1150	0.926	-159	2.15	18	0.016	-57	0.938	-136
1200	0.925	-161	2.04	14	0.015	-58	0.940	-138
1250	0.923	-164	1.95	11	0.014	-62	0.941	-140
1300	0.918	-165	1.87	8	0.013	-68	0.939	-142
1350	0.917	-167	1.79	4	0.012	-71	0.936	-144
1400	0.916	-169	1.72	1	0.012	-74	0.939	-146
1450	0.911	-171	1.63	-2	0.011	-89	0.934	-147
1500	0.904	-172	1.54	-5	0.011	-109	0.933	-148

PD57002 - PD57002S**COMMON SOURCE S-PARAMETER (PD57002)** $(V_{DS} = 13.5V \quad I_{DS} = 75mA)$

FREQ (MHz)	$ S_{11} $	$\angle S_{11}$	$ S_{21} $	$\angle S_{21}$	$ S_{12} $	$\angle S_{12}$	$ S_{22} $	$\angle S_{22}$
50	0.969	-17	10.14	166	0.009	74	0.973	-14
100	0.959	-33	9.72	152	0.017	63	0.954	-27
150	0.949	-48	9.06	139	0.243	50	0.944	-40
200	0.925	-61	8.31	127	0.030	39	0.910	-51
250	0.915	-73	7.57	117	0.033	28	0.901	-61
300	0.906	-83	6.82	108	0.035	20	0.875	-70
350	0.890	-92	6.23	99	0.038	13	0.862	-77
400	0.892	-100	5.65	91	0.039	5	0.866	-85
450	0.888	-106	5.19	84	0.038	-2	0.858	-90
500	0.881	-113	4.72	77	0.039	-6	0.870	-96
550	0.888	-119	4.30	71	0.039	-13	0.873	-102
600	0.882	-123	3.95	65	0.038	-18	0.872	-106
650	0.888	-128	3.62	60	0.038	-24	0.880	-111
700	0.893	-132	3.36	55	0.036	-28	0.890	-116
750	0.890	-135	3.12	51	0.036	-32	0.895	-119
800	0.895	-139	2.92	46	0.034	-36	0.904	-122
850	0.895	-142	2.73	42	0.033	-41	0.911	-126
900	0.893	-145	2.56	37	0.032	-44	0.914	-129
950	0.898	-148	2.40	34	0.030	-47	0.911	-132
1000	0.892	-150	2.25	30	0.030	-50	0.918	-134
1050	0.895	-153	2.13	26	0.029	-54	0.921	-137
1100	0.896	-155	2.20	23	0.028	-58	0.922	-140
1150	0.894	-158	1.92	19	0.027	-60	0.926	-142
1200	0.900	-160	1.83	16	0.026	-64	0.924	-144
1250	0.890	-162	1.74	12	0.025	-67	0.923	-147
1300	0.895	-164	1.67	9	0.024	-72	0.922	-149
1350	0.898	-166	1.58	6	0.023	-73	0.919	-150
1400	0.893	-169	1.51	3	0.023	-79	0.920	-152
1450	0.895	-170	1.43	0	0.021	-86	0.916	-153
1500	0.885	-172	1.35	-1	0.020	-95	0.912	-154

COMMON SOURCE S-PARAMETER (PD57002)(V_{DS} = 13.5V I_{DS} = 150mA)

FREQ (MHz)	S ₁₁	∠S ₁₁	S ₂₁	∠S ₂₁	S ₁₂	∠S ₁₂	S ₂₂	∠S ₂₂
50	0.986	-18	11.58	165	0.009	75	0.964	-14
100	0.972	-34	11.04	151	0.017	62	0.940	-28
150	0.955	-50	10.25	138	0.024	49	0.931	-41
200	0.934	-63	9.35	126	0.029	38	0.891	-52
250	0.921	-75	8.48	115	0.032	28	0.883	-62
300	0.909	-85	7.59	106	0.034	19	0.856	-71
350	0.897	-94	6.93	98	0.036	12	0.841	-78
400	0.895	-102	6.27	90	0.037	4	0.847	-86
450	0.892	-109	5.76	83	0.037	-2	0.840	-91
500	0.889	-115	5.23	76	0.037	-7	0.852	-97
550	0.889	-121	4.75	70	0.037	-13	0.852	-103
600	0.886	-125	4.37	65	0.037	-19	0.853	-107
650	0.891	-130	4.00	59	0.036	-23	0.863	-111
700	0.892	-134	3.72	55	0.035	-29	0.871	-116
750	0.895	-137	3.45	50	0.034	-32	0.878	-119
800	0.897	-141	3.23	46	0.033	-36	0.885	-123
850	0.898	-144	3.02	41	0.032	-40	0.897	-126
900	0.898	-147	2.84	37	0.031	-43	0.895	-129
950	0.902	-149	2.66	33	0.029	-47	0.896	-132
1000	0.90058	-152	2.50	29	0.028	-49	0.904	-134
1050	0.897	-155	2.36	26	0.028	-53	0.906	-137
1100	0.900	-157	2.24	22	0.027	-56	0.909	-140
1150	0.898	-159	2.13	19	0.026	-59	0.912	-142
1200	0.901	-162	2.03	15	0.025	-63	0.910	-144
1250	0.898	-164	1.92	12	0.024	-65	0.913	-147
1300	0.897	-166	1.84	8	0.023	-71	0.912	-149
1350	0.897	-167	1.75	5	0.022	-74	0.909	-150
1400	0.896	-170	1.67	2	0.021	-76	0.912	-152
1450	0.895	-171	1.58	-1	0.021	-85	0.905	-153
1500	0.888	-173	1.50	-2	0.020	-97	0.900	-154

PD57002 - PD57002S**COMMON SOURCE S-PARAMETER (PD57002S)** $(V_{DS} = 28V \quad I_{DS} = 75mA)$

FREQ (MHz)	$ S_{11} $	$\angle S_{11}$	$ S_{21} $	$\angle S_{21}$	$ S_{12} $	$\angle S_{12}$	$ S_{22} $	$\angle S_{22}$
50	0.993	-16	9.99	166	0.007	77	0.929	-12
100	0.987	-31	9.60	153	0.013	64	0.916	-24
150	0.979	-46	9.03	141	0.018	53	0.911	-36
200	0.961	-59	8.36	130	0.022	42	0.889	-46
250	0.950	-71	7.66	119	0.025	32	0.883	-56
300	0.933	-80	6.95	111	0.027	24	0.864	-64
350	0.928	-89	6.39	102	0.029	17	0.860	-71
400	0.924	-97	5.84	94	0.030	8	0.866	-79
450	0.922	-103	5.36	87	0.029	2	0.862	-85
500	0.924	-110	4.90	80	0.030	-2	0.872	-90
550	0.922	-115	4.48	74	0.030	-9	0.877	-96
600	0.923	-120	4.12	69	0.030	-14	0.877	-101
650	0.922	-125	3.78	63	0.029	-19	0.890	-105
700	0.923	-128	3.51	58	0.028	-24	0.892	-110
750	0.925	-132	3.26	54	0.027	-27	0.893	-113
800	0.925	-135	3.04	49	0.026	-31	0.900	-117
850	0.931	-138	2.85	45	0.027	-35	0.907	-120
900	0.933	-141	2.66	41	0.026	-38	0.912	-123
950	0.934	-144	2.49	37	0.024	-41	0.914	-125
1000	0.936	-147	2.35	33	0.023	-45	0.918	-128
1050	0.937	-149	2.21	30	0.023	-47	0.927	-130
1100	0.938	-151	2.10	26	0.022	-50	0.929	-133
1150	0.936	-154	1.99	23	0.022	-53	0.935	-135
1200	0.936	-156	1.91	20	0.021	-56	0.941	-137
1250	0.934	-158	1.81	17	0.020	-60	0.945	-139
1300	0.933	-160	1.75	14	0.019	-65	0.945	-140
1350	0.930	-162	1.67	10	0.018	-67	0.940	-142
1400	0.920	-164	1.58	8	0.018	-69	0.938	-143
1450	0.916	-166	1.51	5	0.017	-78	0.935	-144
1500	0.907	-167	1.43	3	0.017	-88	0.932	-145

COMMON SOURCE S-PARAMETER (PD57002S)

($V_{DS} = 28V$ $I_{DS} = 150mA$)

FREQ (MHz)	$ S_{11} $	$\angle S_{11}$	$ S_{21} $	$\angle S_{21}$	$ S_{12} $	$\angle S_{12}$	$ S_{22} $	$\angle S_{22}$
50	0.997	-17	10.84	166	0.007	77	0.924	-12
100	0.988	-32	10.39	153	0.012	62	0.909	-24
150	0.972	-47	9.73	140	0.017	51	0.904	-36
200	0.962	-60	8.98	129	0.021	42	0.880	-47
250	0.950	-72	8.21	118	0.024	31	0.874	-56
300	0.942	-82	7.43	110	0.026	22	0.856	-64
350	0.934	-91	6.82	101	0.027	15	0.852	-71
400	0.932	-99	6.22	93	0.028	8	0.857	-79
450	0.928	-106	5.70	86	0.028	3	0.853	-84
500	0.924	-112	5.20	79	0.028	-3	0.863	-90
550	0.923	-117	4.74	73	0.029	-9	0.871	-96
600	0.922	-122	4.37	98	0.028	-14	0.869	-100
650	0.922	-126	4.00	62	0.028	-19	0.885	-105
700	0.923	-130	3.71	57	0.027	-25	0.885	-109
750	0.927	-134	3.46	53	0.026	-27	0.888	-113
800	0.926	-137	3.22	48	0.025	-30	0.896	-116
850	0.926	-140	3.01	44	0.024	-35	0.905	-119
900	0.927	-143	2.82	40	0.023	-37	0.908	-122
950	0.927	-146	2.64	36	0.024	-41	0.908	-125
1000	0.928	-148	2.48	32	0.022	-43	0.915	-128
1050	0.927	-151	2.34	29	0.022	-48	0.923	-130
1100	0.928	-153	2.22	25	0.021	-50	0.923	-133
1150	0.927	-155	2.11	22	0.020	-54	0.932	-135
1200	0.925	-157	2.01	18	0.019	-57	0.936	-137
1250	0.926	-159	1.91	15	0.019	-60	0.936	-138
1300	0.921	-161	1.84	12	0.018	-64	0.940	-140
1350	0.919	-163	1.76	9	0.017	-67	0.936	-141
1400	0.915	-164	1.67	7	0.017	-69	0.935	-143
1450	0.912	-166	1.59	4	0.016	-77	0.933	-144
1500	0.907	-168	1.51	2	0.015	-89	0.927	-144

PD57002 - PD57002S

COMMON SOURCE S-PARAMETER (PD57002S)

($V_{DS} = 13.5V$ $I_{DS} = 75mA$)

FREQ (MHz)	$ S_{11} $	$\angle S_{11}$	$ S_{21} $	$\angle S_{21}$	$ S_{12} $	$\angle S_{12}$	$ S_{22} $	$\angle S_{22}$
50	0.996	-17	10.21	165	0.010	73	0.966	-14
100	0.982	-33	9.74	152	0.019	63	0.946	-28
150	0.962	-48	9.07	139	0.027	50	0.938	-41
200	0.946	-61	8.29	127	0.033	39	0.901	-53
250	0.931	-73	7.52	117	0.037	29	0.891	-63
300	0.919	-83	6.73	108	0.040	20	0.863	-72
350	0.911	-92	6.16	100	0.042	13	0.854	-78
400	0.906	-99	5.59	92	0.043	5	0.859	-86
450	0.903	-106	5.11	85	0.043	-1	0.851	-92
500	0.901	-112	4.65	78	0.044	-6	0.860	-97
550	0.900	-117	4.23	73	0.044	-12	0.865	-103
600	0.900	-122	3.89	67	0.044	-17	0.863	-107
650	0.902	-126	3.56	62	0.042	-22	0.879	-112
700	0.902	-130	3.30	57	0.041	-27	0.881	-117
750	0.910	-133	3.07	53	0.040	-30	0.881	-119
800	0.908	-136	2.86	49	0.040	-34	0.891	-123
850	0.910	-139	2.68	44	0.039	-38	0.894	-126
900	0.914	-142	2.51	40	0.038	-42	0.899	-128
950	0.914	-145	2.35	37	0.037	-45	0.902	-131
1000	0.917	-147	2.21	33	0.036	-49	0.907	-133
1050	0.919	-150	2.09	30	0.035	-51	0.918	-136
1100	0.921	-152	1.98	26	0.034	-53	0.914	-138
1150	0.921	-154	1.89	24	0.034	-58	0.928	-140
1200	0.920	-156	1.81	20	0.032	-61	0.927	-142
1250	0.920	-158	1.72	17	0.032	-64	0.930	-144
1300	0.919	-160	1.65	14	0.032	-68	0.928	-146
1350	0.917	-162	1.58	10	0.029	-71	0.921	-147
1400	0.913	-163	1.50	8	0.029	-73	0.923	-149
1450	0.909	-165	1.43	5	0.029	-77	0.921	-149
1500	0.905	-167	1.35	4	0.028	-84	0.913	-150

COMMON SOURCE S-PARAMETER (PD57002S) $(V_{DS} = 13.5V \ I_{DS} = 150mA)$

FREQ (MHz)	$ S_{11} $	$S_{11}\angle\Phi$	$ S_{21} $	$S_{21}\angle\Phi$	$ S_{12} $	$S_{12}\angle\Phi$	$ S_{22} $	$S_{22}\angle\Phi$
50	0.990	-18	11.68	165	0.010	74	0.953	-15
100	0.976	-35	11.11	151	0.019	63	0.932	-28
150	0.952	-50	10.31	138	0.027	49	0.924	-42
200	0.933	-64	9.36	126	0.032	38	0.882	-54
250	0.917	-75	8.44	115	0.036	28	0.872	-64
300	0.905	-85	7.53	107	0.038	19	0.841	-73
350	0.895	-94	6.87	99	0.040	12	0.832	-79
400	0.891	-102	6.22	91	0.041	4	0.838	-87
450	0.886	-108	5.69	84	0.042	-1	0.829	-93
500	0.884	-114	5.17	77	0.042	-7	0.840	-98
550	0.884	-119	4.70	72	0.042	-13	0.847	-104
600	0.883	-124	4.33	66	0.041	-17	0.844	-108
650	0.886	-128	3.95	61	0.041	-22	0.859	-112
700	0.889	-132	3.67	57	0.039	-28	0.860	-117
750	0.892	-135	3.41	52	0.039	-30	0.862	-119
800	0.893	-138	3.18	48	0.038	-35	0.873	-123
850	0.894	-141	2.99	44	0.037	-38	0.876	-126
900	0.894	-144	2.79	40	0.036	-41	0.883	-128
950	0.898	-146	2.62	36	0.035	-45	0.883	-131
1000	0.9	-149	2.46	33	0.035	-47	0.893	-133
1050	0.902	-151	2.32	29	0.034	-51	0.903	-136
1100	0.903	-153	2.21	26	0.033	-54	0.903	-139
1150	0.902	-155	2.10	23	0.032	-58	0.914	-140
1200	0.903	-157	2.01	19	0.031	-61	0.916	-142
1250	0.904	-159	1.91	16	0.031	-63	0.919	-144
1300	0.901	-161	1.85	13	0.029	-68	0.921	-146
1350	0.901	-163	1.76	10	0.028	-71	0.911	-147
1400	0.896	-165	1.67	8	0.028	-73	0.912	-149
1450	0.894	-166	1.59	5	0.028	-78	0.904	-149
1500	0.891	-168	1.51	3	0.026	-85	0.901	-150

PowerSO-10RF Formed Lead (Gull Wing) MECHANICAL DATA

DIM.	mm			Inch		
	MIN.	TYP.	MAX	MIN.	TYP.	MAX
A1	0	0.05	0.1	0.	0.0019	0.0038
A2	3.4	3.5	3.6	0.134	0.137	0.142
A3	1.2	1.3	1.4	0.046	0.05	0.054
A4	0.15	0.2	0.25	0.005	0.007	0.009
a		0.2			0.007	
b	5.4	5.53	5.65	0.212	0.217	0.221
c	0.23	0.27	0.32	0.008	0.01	0.012
D	9.4	9.5	9.6	0.370	0.374	0.377
D1	7.4	7.5	7.6	0.290	0.295	0.298
E	13.85	14.1	14.35	0.544	0.555	0.565
E1	9.3	9.4	9.5	0.365	0.37	0.375
E2	7.3	7.4	7.5	0.286	0.292	0.294
E3	5.9	6.1	6.3	0.231	0.24	0.247
F		0.5			0.019	
G		1.2			0.047	
L	0.8	1	1.1	0.030	0.039	0.042
R1			0.25			0.01
R2		0.8			0.031	
T	2 deg	5 deg	8 deg	2 deg	5 deg	8 deg
T1		6 deg			6 deg	
T2		10 deg			10 deg	

Note (1): Resin protrusions not included (max value: 0.15 mm per side)

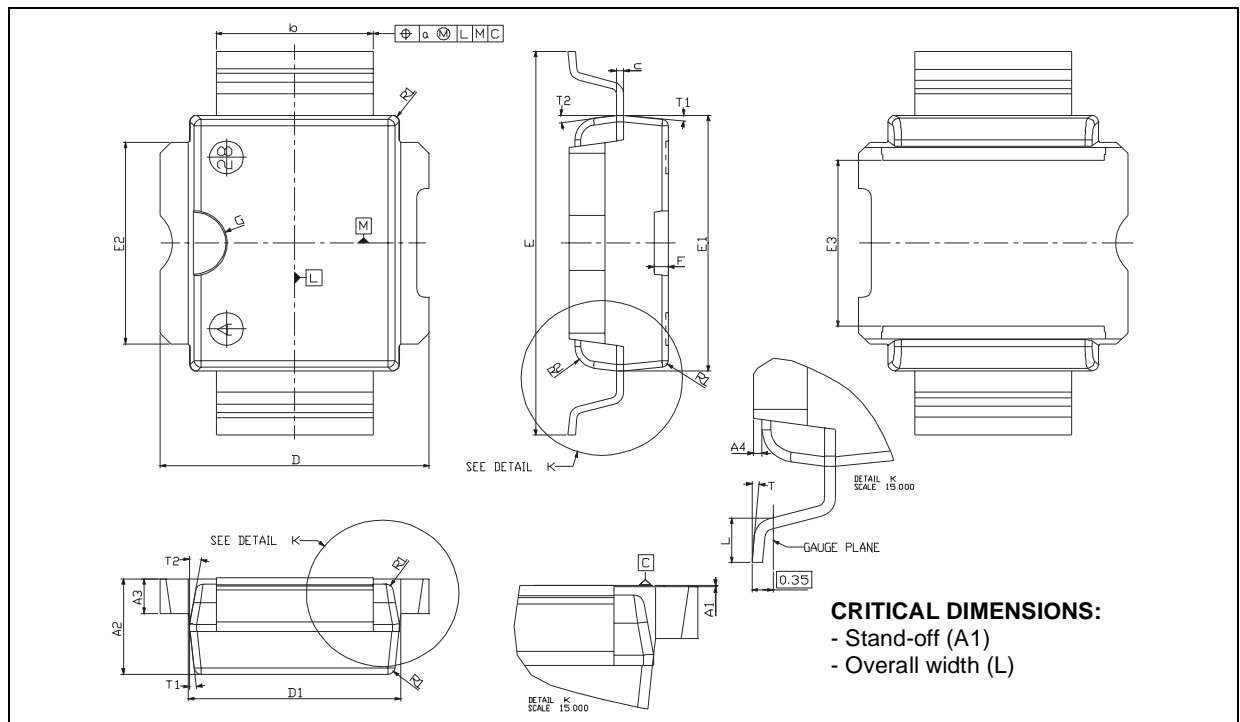

PowerSO-10RF Straight Lead MECHANICAL DATA

DIM.	mm			Inch		
	MIN.	TYP.	MAX	MIN.	TYP.	MAX
A1	1.62	1.67	1.72	0.064	0.065	0.068
A2	3.4	3.5	3.6	0.134	0.137	0.142
A3	1.2	1.3	1.4	0.046	0.05	0.054
A4	0.15	0.2	0.25	0.005	0.007	0.009
a		0.2			0.007	
b	5.4	5.53	5.65	0.212	0.217	0.221
c	0.23	0.27	0.32	0.008	0.01	0.012
D	9.4	9.5	9.6	0.370	0.374	0.377
D1	7.4	7.5	7.6	0.290	0.295	0.298
E	15.15	15.4	15.65	0.595	0.606	0.615
E1	9.3	9.4	9.5	0.365	0.37	0.375
E2	7.3	7.4	7.5	0.286	0.292	0.294
E3	5.9	6.1	6.3	0.231	0.24	0.247
F		0.5			0.019	
G		1.2			0.047	
R1			0.25			0.01
R2		0.8			0.031	
T1		6 deg			6 deg	
T2		10 deg			10 deg	

Note (1): Resin protrusions not included (max value: 0.15 mm per side)

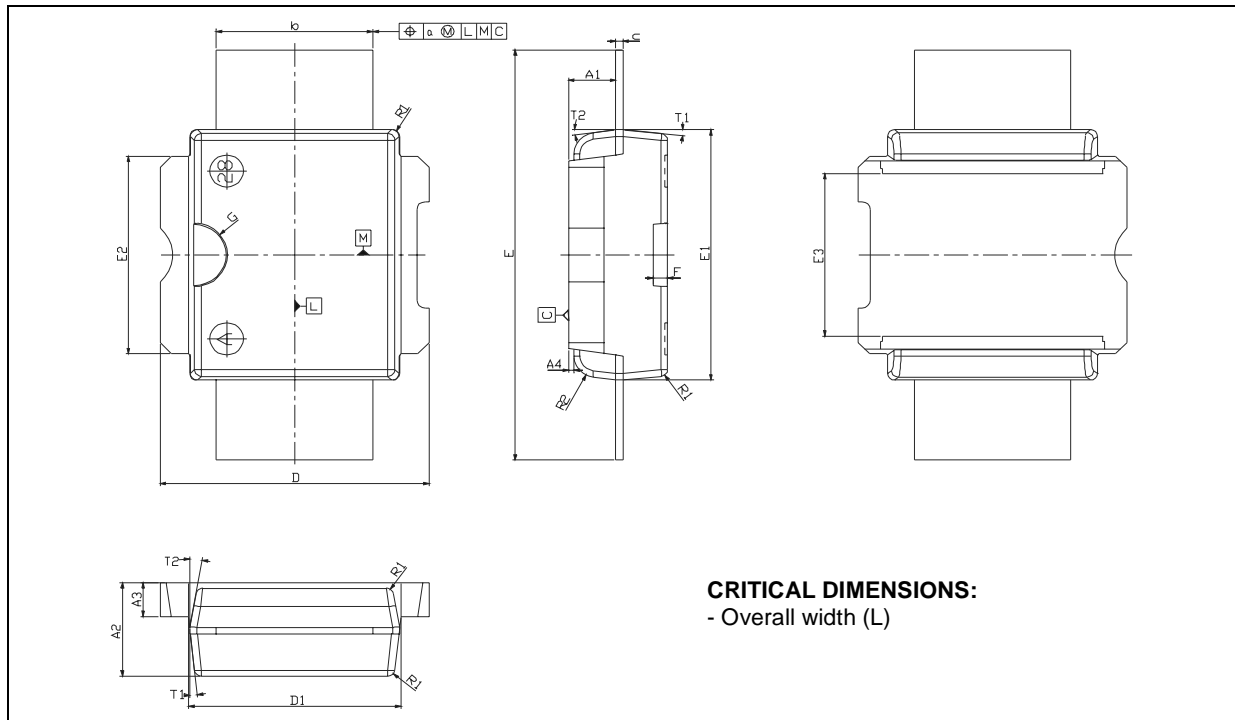

Information furnished is believed to be accurate and reliable. However, STMicroelectronics assumes no responsibility for the consequences of use of such information nor for any infringement of patents or other rights of third parties which may result from its use. No license is granted by implication or otherwise under any patent or patent rights of STMicroelectronics. Specifications mentioned in this publication are subject to change without notice. This publication supersedes and replaces all information previously supplied. STMicroelectronics products are not authorized for use as critical components in life support devices or systems without express written approval of STMicroelectronics.

The ST logo is registered trademark of STMicroelectronics
© 2003 STMicroelectronics - All Rights Reserved

All other names are the property of their respective owners.

STMicroelectronics GROUP OF COMPANIES
Australia - Brazil - China - Finland - France - Germany - Hong Kong - India - Italy - Japan - Malaysia - Malta - Morocco -
Singapore - Spain - Sweden - Switzerland - United Kingdom - U.S.A.

<http://www.st.com>