



Chipsmall Limited consists of a professional team with an average of over 10 year of expertise in the distribution of electronic components. Based in Hongkong, we have already established firm and mutual-benefit business relationships with customers from,Europe,America and south Asia,supplying obsolete and hard-to-find components to meet their specific needs.

With the principle of “Quality Parts,Customers Priority,Honest Operation,and Considerate Service”,our business mainly focus on the distribution of electronic components. Line cards we deal with include Microchip,ALPS,ROHM,Xilinx,Pulse,ON,Everlight and Freescale. Main products comprise IC,Modules,Potentiometer,IC Socket,Relay,Connector.Our parts cover such applications as commercial,industrial, and automotives areas.

We are looking forward to setting up business relationship with you and hope to provide you with the best service and solution. Let us make a better world for our industry!



Contact us

Tel: +86-755-8981 8866 Fax: +86-755-8427 6832

Email & Skype: info@chipsmall.com Web: www.chipsmall.com

Address: A1208, Overseas Decoration Building, #122 Zhenhua RD., Futian, Shenzhen, China



RF power transistor - LdmoST family

Preliminary Data

Features

- Excellent thermal stability
- Common source configuration
- $P_{OUT} = 25\text{ W}$ with 16 dB gain @ 945 MHz / 13.6 V
- BeO free package
- ESD protection
- In compliance with the 2002/95/EC european directive

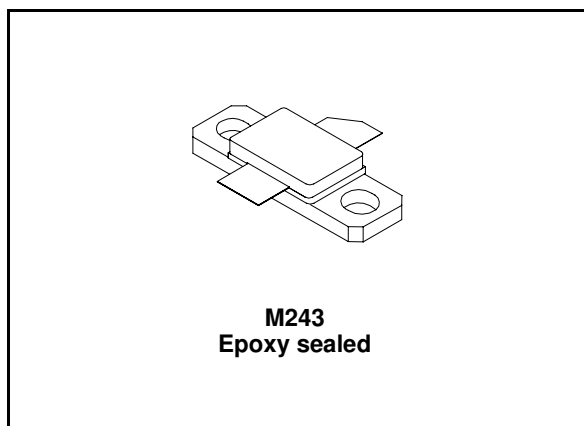

Description

The PD85025C is a common source N-channel, enhancement-mode lateral Field-Effect RF power transistor. It is designed for high gain, broadband commercial and industrial applications. It operates at 13.6 V in common source mode at frequencies of up to 1 GHz. PD85025C boasts the excellent gain, linearity and reliability of ST's latest LDMOS technology.

PD85025C's superior linearity performance makes it an ideal solution for mobile application.

Figure 1. Pin connection

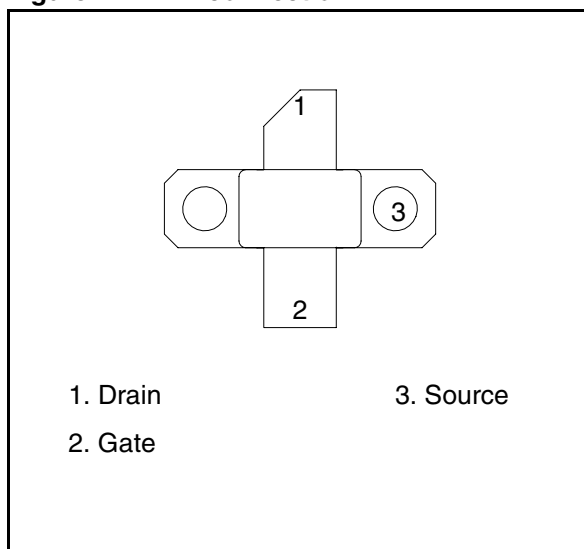

Table 1. Device summary

Order code	Package	Packing
PD85025C	M243	Box

Contents

1	Electrical data	3
1.1	Maximum ratings	3
1.2	Thermal data	3
2	Electrical characteristics	4
2.1	Static	4
2.2	Dynamic	4
2.3	ESD protection characteristics	4
3	Impedance	5
4	Typical performance	6
5	Package mechanical data	8
6	Revision history	9

1 Electrical data

1.1 Maximum ratings

Table 2. Absolute maximum ratings ($T_{CASE} = 25^{\circ}C$)

Symbol	Parameter	Value	Unit
$V_{(BR)DSS}$	Drain-source voltage	40	V
V_{GS}	Gate-source voltage	± 20	V
I_D	Drain current	7	A
P_{DISS}	Power dissipation (@ $T_C = 70^{\circ}C$)	93	W
T_J	Max. operating junction temperature	200	$^{\circ}C$
T_{STG}	Storage temperature	-65 to +150	$^{\circ}C$

1.2 Thermal data

Table 3. Thermal data

Symbol	Parameter	Value	Unit
R_{thJC}	Junction - case thermal resistance	1.4	$^{\circ}C/W$

2 Electrical characteristics

$$T_{CASE} = +25\text{ }^{\circ}\text{C}$$

2.1 Static

Table 4. Static

Symbol	Test conditions		Min	Typ	Max	Unit
I_{DSS}	$V_{GS} = 0\text{ V}$	$V_{DS} = 25\text{ V}$			1	μA
I_{GSS}	$V_{GS} = 20\text{ V}$	$V_{DS} = 0\text{ V}$			1	μA
$V_{GS(Q)}$	$V_{DS} = 10\text{ V}$	$I_D = \text{TBD mA}$		TBD		V
$V_{DS(ON)}$	$V_{GS} = 10\text{ V}$	$I_D = 1\text{ A}$		270	310	mV
C_{ISS}	$V_{GS} = 0\text{ V}$	$V_{DS} = 12.5\text{ V}$		49		pF
C_{OSS}	$V_{GS} = 0\text{ V}$	$V_{DS} = 12.5\text{ V}$		35		pF
C_{RSS}	$V_{GS} = 0\text{ V}$	$V_{DS} = 12.5\text{ V}$		1.0		pF

2.2 Dynamic

Table 5. Dynamic

Symbol	Test conditions	Min.	Typ.	Max.	Unit
P3dB	$V_{DD} = 13.6\text{ V}$, $I_{DQ} = 300\text{ mA}$ $f = 945\text{ MHz}$	25	30		W
G_P	$V_{DD} = 13.6\text{ V}$, $I_{DQ} = 300\text{ mA}$, $P_{OUT} = 10\text{ W}$, $f = 945\text{ MHz}$	15	17.5		dB
h_D	$V_{DD} = 13.6\text{ V}$, $I_{DQ} = 300\text{ mA}$, $P_{OUT} = \text{P3dB}$, $f = 945\text{ MHz}$	60	73		%
Load mismatch	$V_{DD} = 17\text{ V}$, $I_{DQ} = 300\text{ mA}$, $P_{OUT} = 45\text{ W}$, $f = 945\text{ MHz}$ All phase angles	20:1			VSWR

2.3 ESD protection characteristics

Table 6. ESD protection characteristics

Test conditions	Class
Human body model	2
Machine model	M3

3 Impedance

Figure 2. Current conventions

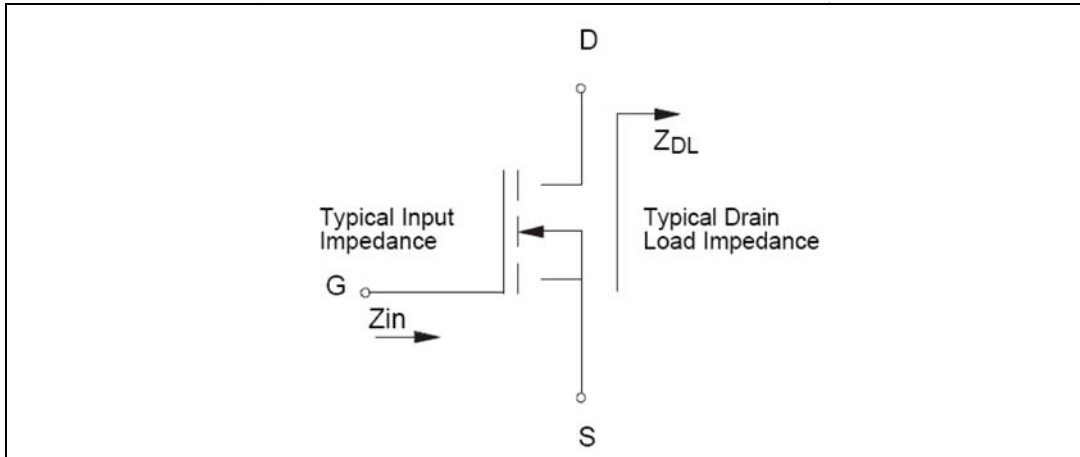

Table 7. Impedance data

Freq. (MHz)	$Z_{IN} (\Omega)$	$Z_{DL}(\Omega)$
945 MHz	$1.01 + j 2.03$	$1.75 + j 2.20$

4 Typical performance

Figure 3. Capacitances vs drain voltage

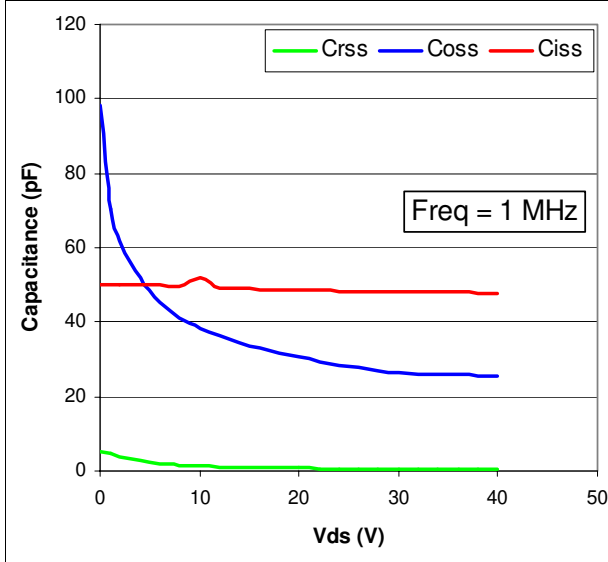

Figure 4. DC output characteristics

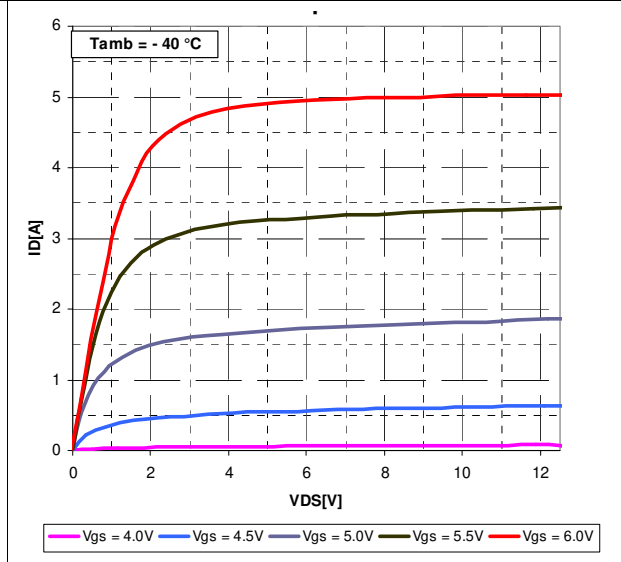

Figure 5. DC output characteristics

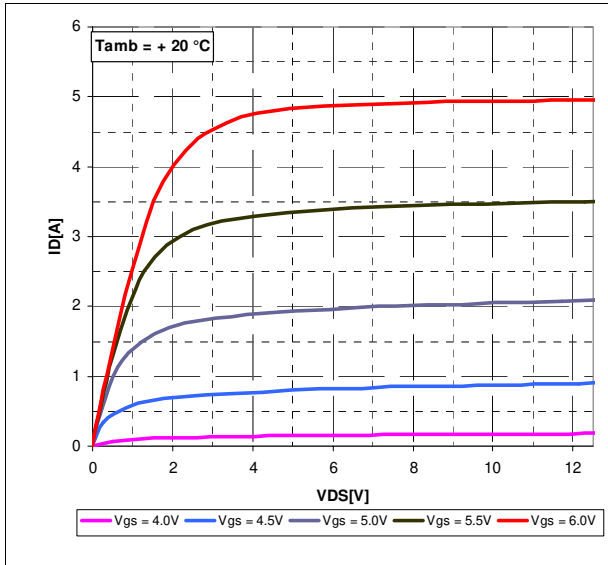

Figure 6. DC output characteristic

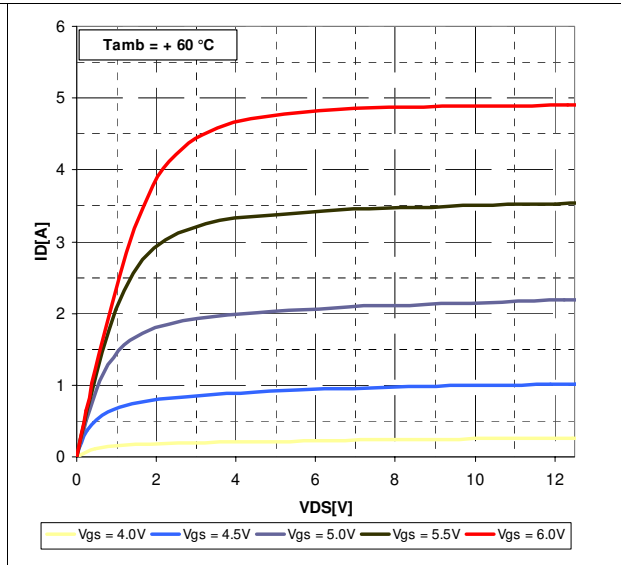

Figure 7. Output power and efficiency vs input power

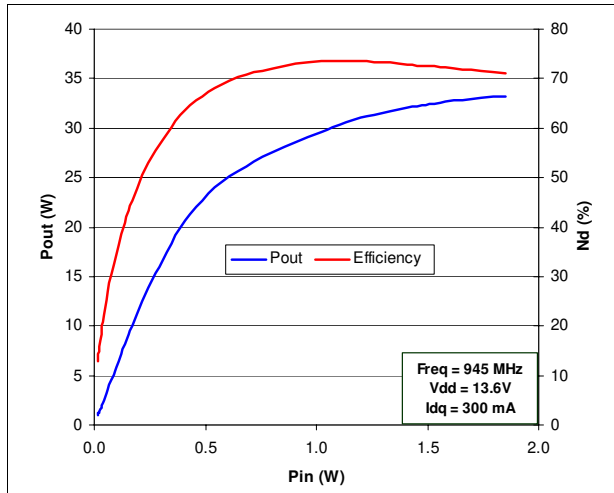

Figure 8. Gain vs output power and bias current

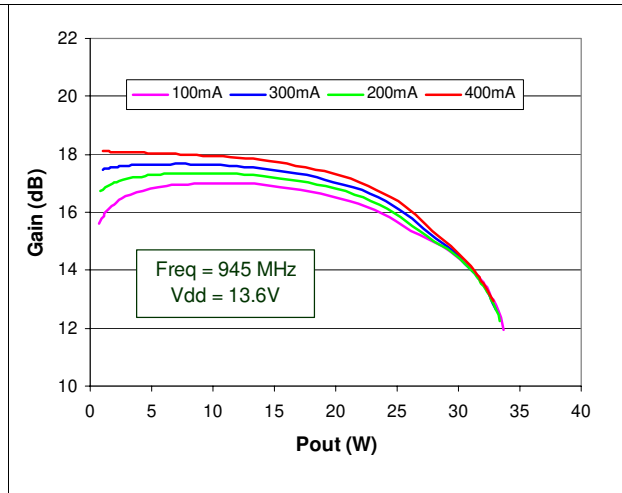

Figure 9. Pout and drain current vs gate voltage

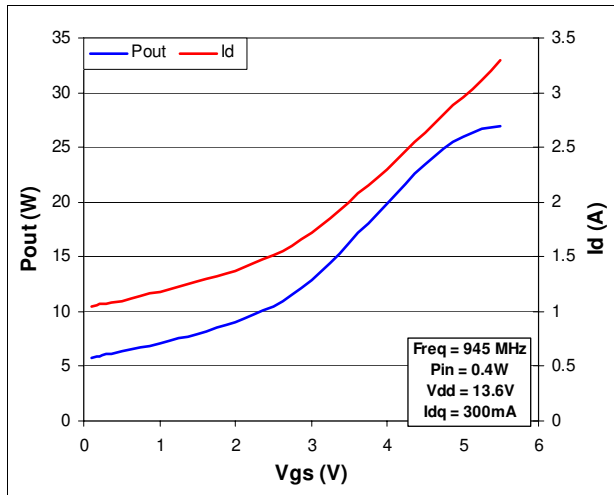

Figure 10. Pout and drain current vs supply voltage

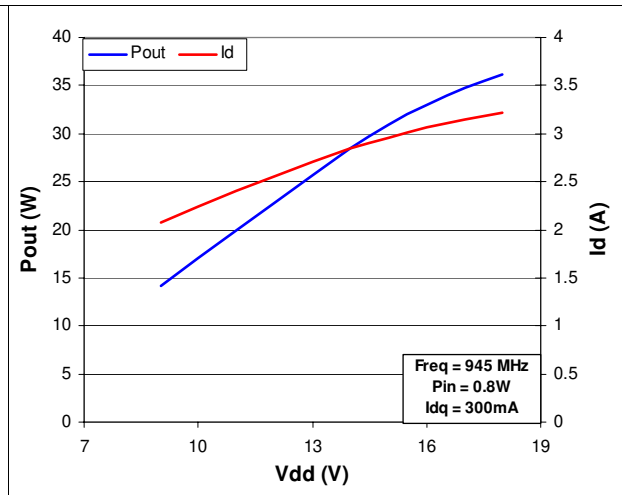
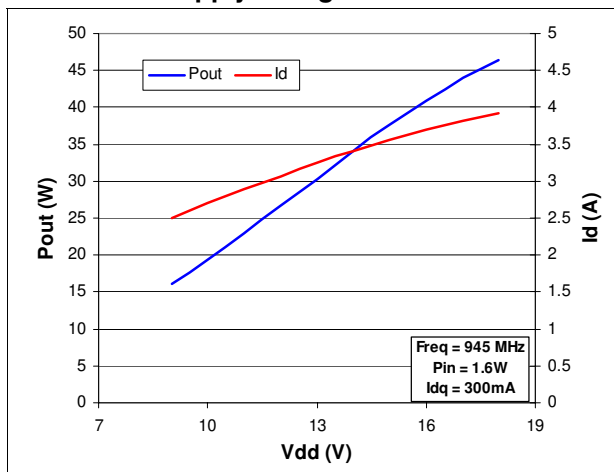

Figure 11. Pout and drain current vs supply voltage



5 Package mechanical data

In order to meet environmental requirements, ST offers these devices in ECOPACK® packages. These packages have a Lead-free second level interconnect . The category of second level interconnect is marked on the package and on the inner box label, in compliance with JEDEC Standard JESD97. The maximum ratings related to soldering conditions are also marked on the inner box label. ECOPACK is an ST trademark. ECOPACK specifications are available at: www.st.com

Table 8. M243 (.230 x .360 2L N/HERM W/FLG) mechanical data

Dim.	mm.			Inch		
	Min	Typ	Max	Min	Typ	Max
A	5.21		5.72	0.205		0.225
B	5.46		6.48	0.215		0.255
C	5.59		6.10	0.220		0.240
D		14.27			0.562	
E	20.07		20.57	0.790		0.810
F	8.89		9.40	0.350		0.370
G	0.10		0.15	0.004		0.006
H	3.18		4.45	0.125		0.175
I	1.83		2.24	0.072		0.088
J	1.27		1.78	0.050		0.070

Figure 12. Package dimensions

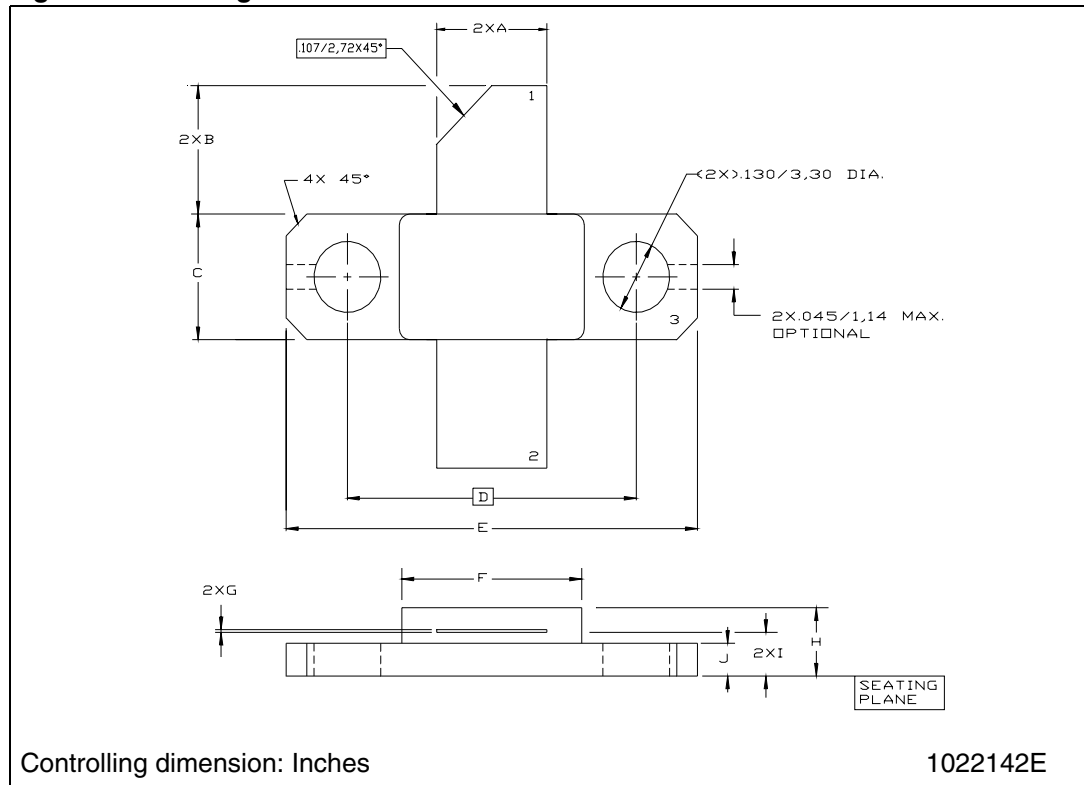

6 Revision history

Table 9. Document revision history

Date	Revision	Changes
10-Dec-2007	1	Initial release.

Please Read Carefully:

Information in this document is provided solely in connection with ST products. STMicroelectronics NV and its subsidiaries ("ST") reserve the right to make changes, corrections, modifications or improvements, to this document, and the products and services described herein at any time, without notice.

All ST products are sold pursuant to ST's terms and conditions of sale.

Purchasers are solely responsible for the choice, selection and use of the ST products and services described herein, and ST assumes no liability whatsoever relating to the choice, selection or use of the ST products and services described herein.

No license, express or implied, by estoppel or otherwise, to any intellectual property rights is granted under this document. If any part of this document refers to any third party products or services it shall not be deemed a license grant by ST for the use of such third party products or services, or any intellectual property contained therein or considered as a warranty covering the use in any manner whatsoever of such third party products or services or any intellectual property contained therein.

UNLESS OTHERWISE SET FORTH IN ST'S TERMS AND CONDITIONS OF SALE ST DISCLAIMS ANY EXPRESS OR IMPLIED WARRANTY WITH RESPECT TO THE USE AND/OR SALE OF ST PRODUCTS INCLUDING WITHOUT LIMITATION IMPLIED WARRANTIES OF MERCHANTABILITY, FITNESS FOR A PARTICULAR PURPOSE (AND THEIR EQUIVALENTS UNDER THE LAWS OF ANY JURISDICTION), OR INFRINGEMENT OF ANY PATENT, COPYRIGHT OR OTHER INTELLECTUAL PROPERTY RIGHT.

UNLESS EXPRESSLY APPROVED IN WRITING BY AN AUTHORIZED ST REPRESENTATIVE, ST PRODUCTS ARE NOT RECOMMENDED, AUTHORIZED OR WARRANTED FOR USE IN MILITARY, AIR CRAFT, SPACE, LIFE SAVING, OR LIFE SUSTAINING APPLICATIONS, NOR IN PRODUCTS OR SYSTEMS WHERE FAILURE OR MALFUNCTION MAY RESULT IN PERSONAL INJURY, DEATH, OR SEVERE PROPERTY OR ENVIRONMENTAL DAMAGE. ST PRODUCTS WHICH ARE NOT SPECIFIED AS "AUTOMOTIVE GRADE" MAY ONLY BE USED IN AUTOMOTIVE APPLICATIONS AT USER'S OWN RISK.

Resale of ST products with provisions different from the statements and/or technical features set forth in this document shall immediately void any warranty granted by ST for the ST product or service described herein and shall not create or extend in any manner whatsoever, any liability of ST.

ST and the ST logo are trademarks or registered trademarks of ST in various countries.

Information in this document supersedes and replaces all information previously supplied.

The ST logo is a registered trademark of STMicroelectronics. All other names are the property of their respective owners.

© 2007 STMicroelectronics - All rights reserved

STMicroelectronics group of companies

Australia - Belgium - Brazil - Canada - China - Czech Republic - Finland - France - Germany - Hong Kong - India - Israel - Italy - Japan - Malaysia - Malta - Morocco - Singapore - Spain - Sweden - Switzerland - United Kingdom - United States of America

www.st.com