



Chipsmall Limited consists of a professional team with an average of over 10 year of expertise in the distribution of electronic components. Based in Hongkong, we have already established firm and mutual-benefit business relationships with customers from,Europe,America and south Asia,supplying obsolete and hard-to-find components to meet their specific needs.

With the principle of "Quality Parts,Customers Priority,Honest Operation,and Considerate Service",our business mainly focus on the distribution of electronic components. Line cards we deal with include Microchip,ALPS,ROHM,Xilinx,Pulse,ON,Everlight and Freescale. Main products comprise IC,Modules,Potentiometer,IC Socket,Relay,Connector.Our parts cover such applications as commercial,industrial, and automotives areas.

We are looking forward to setting up business relationship with you and hope to provide you with the best service and solution. Let us make a better world for our industry!



## Contact us

Tel: +86-755-8981 8866 Fax: +86-755-8427 6832

Email & Skype: info@chipsmall.com Web: www.chipsmall.com

Address: A1208, Overseas Decoration Building, #122 Zhenhua RD., Futian, Shenzhen, China



# PHOTONIC DETECTORS INC.

## Silicon Photodiode, Blue Enhanced Photoconductive Type PDB-C106

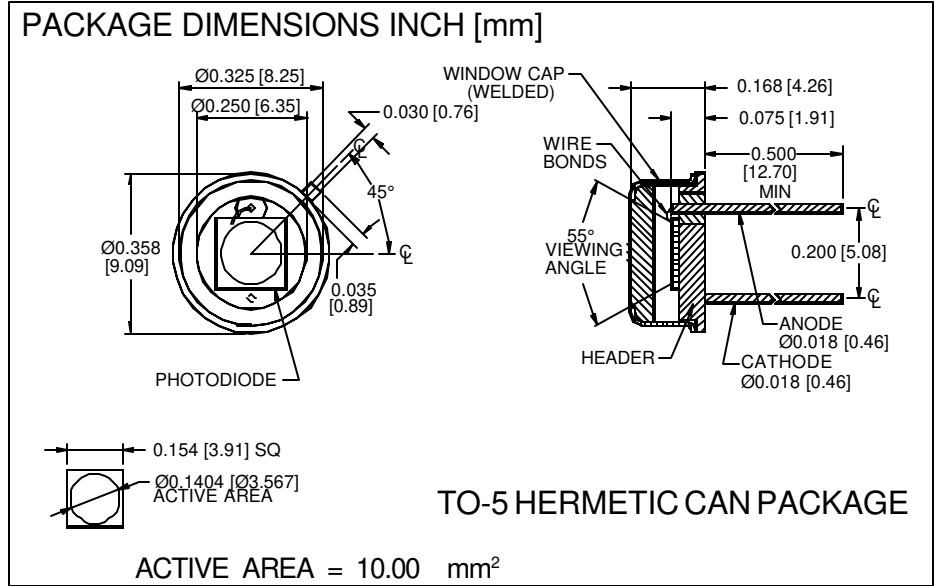

### FEATURES

- High speed
- Low capacitance
- Blue enhanced
- Low dark current

### DESCRIPTION

The **PDB-C106** is a silicon, PIN planar diffused, blue enhanced photodiode. Ideal for high speed photoconductive applications. Packaged in a hermetic TO-5 metal can with a flat window.

### APPLICATIONS

- Instrumentation
- Analytical measurements
- Laser sensor
- Industrial sensor

### ABSOLUTE MAXIMUM RATING (TA=25°C unless otherwise noted)

SYMBOL	PARAMETER	MIN	MAX	UNITS
V <sub>BR</sub>	Reverse Voltage		100	V
T <sub>STG</sub>	Storage Temperature	-55	+150	°C
To	Operating Temperature Range	-40	+125	°C
T <sub>s</sub>	Soldering Temperature*		+240	°C
I <sub>L</sub>	Light Current		500	mA

\*1/16 inch from case for 3 secs max

### SPECTRAL RESPONSE

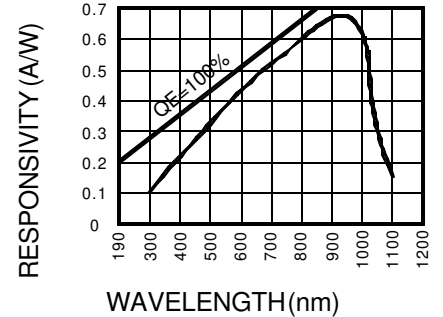

### ELECTRO-OPTICAL CHARACTERISTICS (TA=25°C unless otherwise noted)

SYMBOL	CHARACTERISTIC	TEST CONDITIONS	MIN	TYP	MAX	UNITS
I <sub>SC</sub>	Short Circuit Current	H = 100 fc, 2850 K	100	130		μA
I <sub>D</sub>	Dark Current	H = 0, V <sub>R</sub> = 10 V		2	10	nA
R <sub>SH</sub>	Shunt Resistance	H = 0, V <sub>R</sub> = 10 mV	200	650		MΩ
TC R <sub>SH</sub>	RSH Temp. Coefficient	H = 0, V <sub>R</sub> = 10 mV		-8		% / °C
C <sub>J</sub>	Junction Capacitance	H = 0, V <sub>R</sub> = 10 V**		70		pF
λ <sub>range</sub>	Spectral Application Range	Spot Scan	350		1100	nm
λ <sub>p</sub>	Spectral Response - Peak	Spot Scan		950		nm
V <sub>BR</sub>	Breakdown Voltage	I = 10 μA	75	100		V
NEP	Noise Equivalent Power	V <sub>R</sub> = 10 V @ Peak		3x10 <sup>-14</sup>		W/√Hz
tr	Response Time	RL = 1 KΩ V <sub>R</sub> = 50 V		18		nS

Information in this technical data sheet is believed to be correct and reliable. However, no responsibility is assumed for possible inaccuracies or omission. Specifications are subject to change without notice. \*\*f = 1 MHz

[FORM NO. 100-PDB-C106 REV C]