



Chipsmall Limited consists of a professional team with an average of over 10 year of expertise in the distribution of electronic components. Based in Hongkong, we have already established firm and mutual-benefit business relationships with customers from,Europe,America and south Asia,supplying obsolete and hard-to-find components to meet their specific needs.

With the principle of “Quality Parts,Customers Priority,Honest Operation,and Considerate Service”,our business mainly focus on the distribution of electronic components. Line cards we deal with include Microchip,ALPS,ROHM,Xilinx,Pulse,ON,Everlight and Freescale. Main products comprise IC,Modules,Potentiometer,IC Socket,Relay,Connector.Our parts cover such applications as commercial,industrial, and automotives areas.

We are looking forward to setting up business relationship with you and hope to provide you with the best service and solution. Let us make a better world for our industry!



## Contact us

Tel: +86-755-8981 8866 Fax: +86-755-8427 6832

Email & Skype: info@chipsmall.com Web: www.chipsmall.com

Address: A1208, Overseas Decoration Building, #122 Zhenhua RD., Futian, Shenzhen, China



# PHOTONIC DETECTORS INC.

## Silicon Photodiode, Blue Enhanced Photovoltaic Isolated Type PDB-V101-I

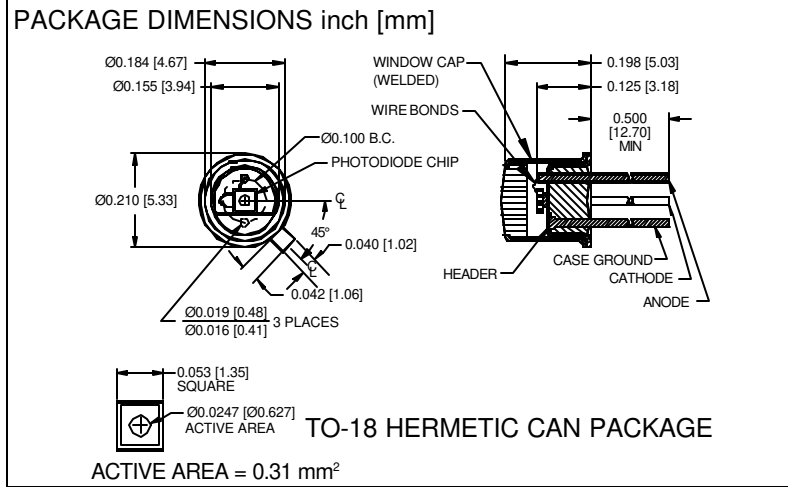

### FEATURES

- Low noise
- Blue enhanced
- High shunt resistance
- High response

### DESCRIPTION

The **PDB-V101-I** is a silicon, PIN planar diffused, blue enhanced photodiode. Ideal for low noise photovoltaic applications. Packaged in a hermetic TO-18 metal can with a flat window and isolated ground lead.

### APPLICATIONS

- Instrumentation
- Industrial controls
- Laser detection
- Particle detection

### ABSOLUTE MAXIMUM RATING (TA=25°C unless otherwise noted)

SYMBOL	PARAMETER	MIN	MAX	UNITS
V <sub>BR</sub>	Reverse Voltage		75	V
T <sub>STG</sub>	Storage Temperature	-55	+150	°C
T <sub>O</sub>	Operating Temperature Range	-40	+125	°C
T <sub>S</sub>	Soldering Temperature*		+240	°C
I <sub>L</sub>	Light Current		.5	mA

\*1/16 inch from case for 3 secs max

### SPECTRAL RESPONSE

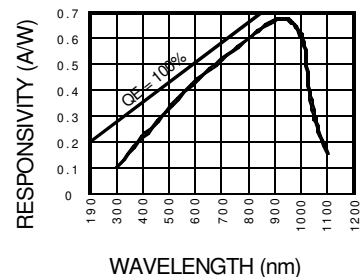

### ELECTRO-OPTICAL CHARACTERISTICS (TA=25°C unless otherwise noted)

SYMBOL	CHARACTERISTIC	TEST CONDITIONS	MIN	TYP	MAX	UNITS
I <sub>SC</sub>	Short Circuit Current	H = 100 fc, 2850 K	4	4.5		mA
I <sub>D</sub>	Dark Current	H = 0, V <sub>R</sub> = 10 V		20	45	pA
R <sub>SH</sub>	Shunt Resistance	H = 0, V <sub>R</sub> = 10 mV	1	1.6		GW
TC R <sub>SH</sub>	RSH Temp. Coefficient	H = 0, V <sub>R</sub> = 10 mV		-8		% / °C
C <sub>J</sub>	Junction Capacitance	H = 0, V <sub>R</sub> = 0 V**		115		pF
λ range	Spectral Application Range	Spot Scan	350		1100	nm
λ p	Spectral Response - Peak	Spot Scan		950		nm
V <sub>BR</sub>	Breakdown Voltage	I = 10 mA	30	50		V
NEP	Noise Equivalent Power	V <sub>R</sub> = 10 mV @ Peak		2.5x10 <sup>-15</sup>		W/√Hz
tr	Response Time	RL = 1 KΩ V <sub>R</sub> = 0 V		450		nS

Information in this technical data sheet is believed to be correct and reliable. However, no responsibility is assumed for possible inaccuracies or omission. Specifications are subject to change without notice. \*\*f = 1 MHz