



Chipsmall Limited consists of a professional team with an average of over 10 year of expertise in the distribution of electronic components. Based in Hongkong, we have already established firm and mutual-benefit business relationships with customers from,Europe,America and south Asia,supplying obsolete and hard-to-find components to meet their specific needs.

With the principle of “Quality Parts,Customers Priority,Honest Operation,and Considerate Service”,our business mainly focus on the distribution of electronic components. Line cards we deal with include Microchip,ALPS,ROHM,Xilinx,Pulse,ON,Everlight and Freescale. Main products comprise IC,Modules,Potentiometer,IC Socket,Relay,Connector.Our parts cover such applications as commercial,industrial, and automotives areas.

We are looking forward to setting up business relationship with you and hope to provide you with the best service and solution. Let us make a better world for our industry!



Contact us

Tel: +86-755-8981 8866 Fax: +86-755-8427 6832

Email & Skype: info@chipsmall.com Web: www.chipsmall.com

Address: A1208, Overseas Decoration Building, #122 Zhenhua RD., Futian, Shenzhen, China



PHOTONIC DETECTORS INC.

High-Power & Current GaAs Infrared Emitters Peak Wavelength 940 nm, Type PDI-E911

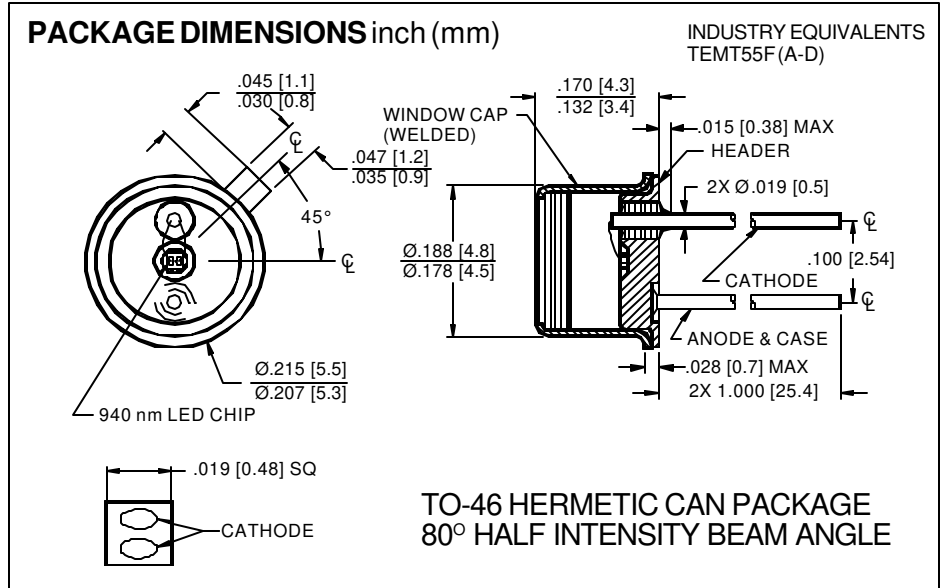
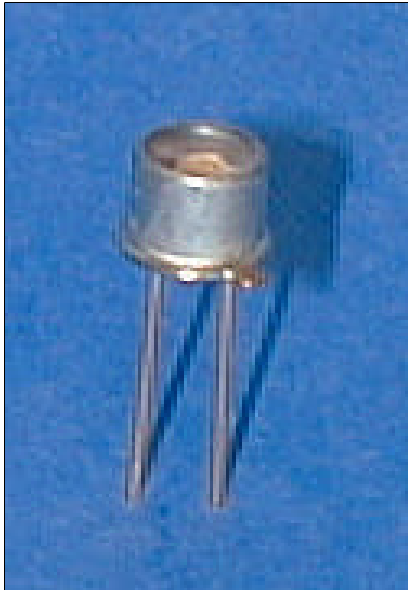

FEATURES

- Dual cathode
- High current
- Medium- high emission angle

DESCRIPTION: The PDI-E911 infrared emitting diode uses dual cathode, high current reliability liquid phase epitaxially grown GaAs. Optimized for high power, high current at 940 nm. Packaged in a TO-46 can with a flat glass window cap.

APPLICATIONS

- Photoelectric switches
- Reflective switches
- Smoke detectors

ABSOLUTE MAXIMUM RATING (TA=25°C unless otherwise noted)

SYMBOL	PARAMETER	MIN	MAX	UNITS
Pd	Power Dissipation		360	mW
I _{FP}	Continuous Forward Current		180	mA
I _{FP}	Peak Forward Current (100µs pulse, 10pps)		3.0	A
V _R	Reverse voltage		3.0	V
To & Ts	Storage & Operating Temperature	-65	+125	°C
TS	Soldering Temperature*		+260	°C

*1/16 inch from case for 3 secs max

TYPICAL RADIATION PATTERN

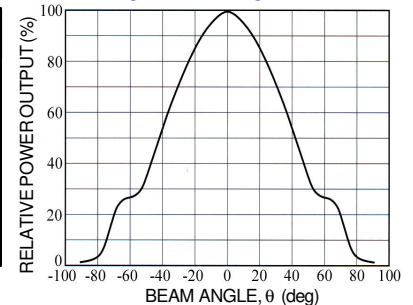

ELECTRO-OPTICAL CHARACTERISTICS (TA=25°C unless otherwise noted)

SYMBOL	CHARACTERISTIC	TEST CONDITIONS	MIN	TYP	MAX	UNITS
P _o	Output Power	I _F = 100 mA	1.0	5.0		mW
V _F	Forward Voltage	I _F = 100 mA		1.35	1.75	V
I _R	Reverse Current	V _r = -3.0 V			10	µA
λ _p	Peak Wavelength	I _F = 50 mA	925	940	955	nm
Δλ	Spectral Halfwidth	I _F = 50 mA		50		nm
R _d	Dynamic Resistance	I _F = 100 mA		0.6		Ohms
t _r	Rise Time	I _F = 100 mA		1.1		µs
t _f	Fall Time	I _F = 100 mA		1.5		µs

POWER OUTPUT vs FORWARD CURRENT

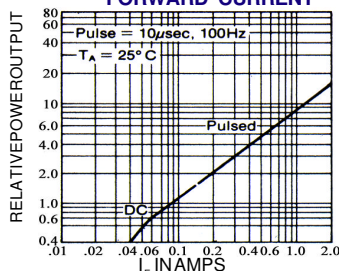

TYPICAL POWER OUTPUT DEGRADATION CURVE

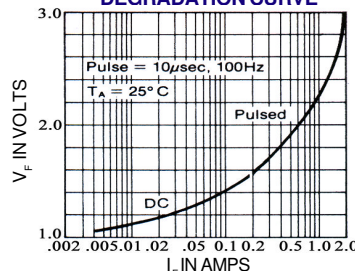

SPECTRAL OUTPUT

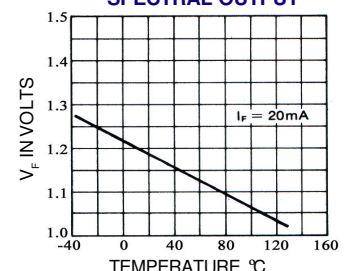

Information in this technical data sheet is believed to be correct and reliable. However, no responsibility is assumed for possible inaccuracies or omission. Specifications are subject to change without notice. Optical power and radiant intensity measured using uncapped dimpled TO-46 into integrating sphere. [FORM NO. 100-PDI-E911 REV C]