



Chipsmall Limited consists of a professional team with an average of over 10 year of expertise in the distribution of electronic components. Based in Hongkong, we have already established firm and mutual-benefit business relationships with customers from,Europe,America and south Asia,supplying obsolete and hard-to-find components to meet their specific needs.

With the principle of “Quality Parts,Customers Priority,Honest Operation,and Considerate Service”,our business mainly focus on the distribution of electronic components. Line cards we deal with include Microchip,ALPS,ROHM,Xilinx,Pulse,ON,Everlight and Freescale. Main products comprise IC,Modules,Potentiometer,IC Socket,Relay,Connector.Our parts cover such applications as commercial,industrial, and automotives areas.

We are looking forward to setting up business relationship with you and hope to provide you with the best service and solution. Let us make a better world for our industry!



Contact us

Tel: +86-755-8981 8866 Fax: +86-755-8427 6832

Email & Skype: info@chipsmall.com Web: www.chipsmall.com

Address: A1208, Overseas Decoration Building, #122 Zhenhua RD., Futian, Shenzhen, China



PHOTONIC DETECTORS INC.

Silicon Photodiode, Filter Combination Photovoltaic (center wavelength 800 nm) Type PDI-V480

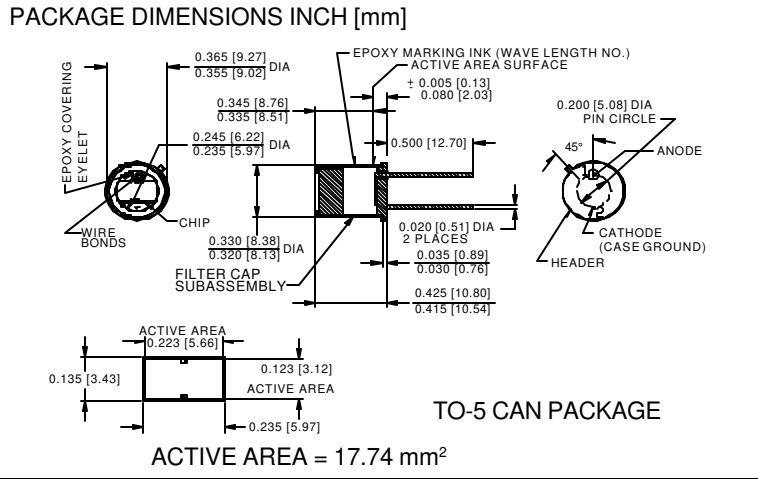

FEATURES

- High transmission
- 10⁻⁴ rejection
- +/- 2nm CWL

DESCRIPTION

The **PDI-V480** is a silicon, PIN planar diffused, photodiode with a narrow band interference filter. The detector filter combination has a narrow 10 nm half bandwidth designed for low noise photovoltaic applications. Packaged in a TO-5 metal can.

APPLICATIONS

- Spectrophotometry
- Chemistry instrumentation
- Liquid chromatography

ABSOLUTE MAXIMUM RATING (TA=25°C unless otherwise noted)

SYMBOL	PARAMETER	MIN	MAX	UNITS
V _{BR}	Reverse Voltage		100	V
T _{STG}	Storage Temperature	-20	+85	°C
T _O	Operating Temperature Range	-15	+70	°C
T _S	Soldering Temperature*		+240	°C
I _L	Light Current		0.5	mA

*1/16 inch from case for 3 secs max

SPECTRAL RESPONSE

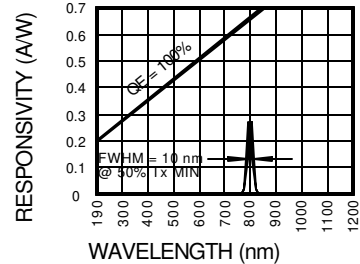

ELECTRO-OPTICAL CHARACTERISTICS (TA=25°C unless otherwise noted)

SYMBOL	CHARACTERISTIC	TEST CONDITIONS	MIN	TYP	MAX	UNITS
I _{SC}	Short Circuit Current***	H = 100 fc, 2850 K	150	200		μA
I _D	Dark Current	H = 0, V _R = 10 mV		10	50	pA
R _{SH}	Shunt Resistance	H = 0, V _R = 10 mV	.20	2		Ω
TC R _{SH}	R _{SH} Temp. Coefficient	H = 0, V _R = 10 mV		-8		% / °C
C _J	Junction Capacitance	H = 0, V _R = 10 V**		1700		pF
CWL	Center Wavelength	(CWL, λ ₀) +/- 2 nm		800		nm
HBW	Half Bandwidth	(FWHM)		10		nm
V _{BR}	Breakdown Voltage	I = 10 μA	50	75		V
NEP	Noise Equivalent Power	V _R = 10 mV @ Peak		9x10 ⁻¹⁵		W/√Hz
tr	Response Time	RL = 1 KΩ V _R = 10 V		1.0		μS

Information in this technical data sheet is believed to be correct and reliable. However, no responsibility is assumed for possible inaccuracies or omission. Specifications are subject to change without notice.**f = 1 MHz, ***without filter

[FORM NO. 100-PDI-V480 REV B]