



Chipsmall Limited consists of a professional team with an average of over 10 year of expertise in the distribution of electronic components. Based in Hongkong, we have already established firm and mutual-benefit business relationships with customers from,Europe,America and south Asia,supplying obsolete and hard-to-find components to meet their specific needs.

With the principle of “Quality Parts,Customers Priority,Honest Operation,and Considerate Service”,our business mainly focus on the distribution of electronic components. Line cards we deal with include Microchip,ALPS,ROHM,Xilinx,Pulse,ON,Everlight and Freescale. Main products comprise IC,Modules,Potentiometer,IC Socket,Relay,Connector.Our parts cover such applications as commercial,industrial, and automotives areas.

We are looking forward to setting up business relationship with you and hope to provide you with the best service and solution. Let us make a better world for our industry!



Contact us

Tel: +86-755-8981 8866 Fax: +86-755-8427 6832

Email & Skype: info@chipsmall.com Web: www.chipsmall.com

Address: A1208, Overseas Decoration Building, #122 Zhenhua RD., Futian, Shenzhen, China



HWB12 SEALED POWER DISTRIBUTION MODULE

Compact Hard-Wired PDM for 280 Style Components

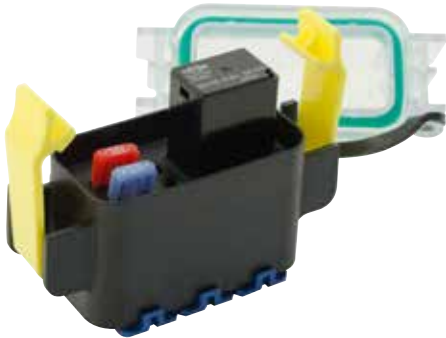

Description

The HWB12 Compact Hard-Wired Box features 12 cavities that accept 2.8mm fuse and relay components and is the perfect fit for accessory circuits and overflow circuits from your main Power Distribution module. The HWB12 can hold plug-in components including MINI fuses, MINI format circuit breakers, 4-pin single throw relays, and 5-pin double throw relays. The HWB12 features durable construction, an IP67/IP69K rating, and a compact size. The user can customize their own circuitry utilizing direct wire-to-component connections which are crimped to the wire harness with grommets to seal the bottom of the module.

Features and Benefits

- AssureLatch™ yellow positive-sealing latches keep the cover securely in place while allowing for fast service.
- Accepts any MINI (280 style) fuses, circuit breakers or relays.
- Compact size allows the unit to be installed in vehicles with limited space.
- Ideal for accessory circuits, overflow circuits from main
- IP67/IP69K sealed units can be installed virtually anywhere on the vehicle and stands up to road splash and salt spray.
- TPAs (terminal position assurance locks) give secondary locking protection of the wire leads, which help keeps leads securely in place.
- Wires plug into the back of the unit using industry-standard TE Connectivity MCP terminals.
- Tethers available to prevent loss of cover during service.
- Optional foam on inside cover available; functions as relay retention insert
- HWB18, HWB12 & HWB6 share the same mounting bracket so electrical system modification can be performed without bracket or sheet metal alterations.
- A UL certification for this fuseholder means it can be used as a component in material handling and electric-battery-powered industrial truck applications with confidence that it meets the requirements of UL 583 standards.

Specifications Overview

Max Fuse Rating:	30A per circuit
Max Continuous Current:	130A
Number of Cavities	12
Operating Temp:	-40 °C to +105 °C
Ingress Protection:	IP67/IP69K

Applications

- Accessory circuits
- Overflow circuits
- Main unit on small vehicles
- Upfitting vehicle electrical systems

Web Resources

Download 2D print and technical resources at: littelfuse.com/hwb12

Ordering Information

PART NUMBER	COVER		AssureLatch™		MOUNTING BRACKET
	BLACK	CLEAR			
PDM33001ZXM		•	•		
PDM33002ZXM	•		•	•	
PDM33003ZXM		•	•		Straight
PDM33004ZXM	•		•	•	Straight

UR file number: AU6325

TPA: Terminal Position Assurance secondary locks for wire terminals

Accessories and Service Parts

PART NUMBER	DESCRIPTION
868-094	Base
873-021-001	Cover in clear
873-021-002	Cover in black (UR)
901-326	Silicone seal
883-088	1 pcs. AssureLatch™ with thumb release
883-087	TPA
890009470	Tether
901-327	Foam insert
868-964	90° angle mounting bracket
868-068	30° angle mounting bracket

HWB12 SEALED POWER DISTRIBUTION MODULE

Specifications

Max Fuse Rating	30A per circuit
Max Continuous Current	130A
Number of Cavities	12
Recommended Mounting	M6 bolt and lock washer
Mounting Bracket Torque	5.5-6.5 Nm
Temperature Range	-40 °C to +105 °C
Ingress Protection Rating	IP67/IP69K
Dimensions	83.2x69.6x43.6 mm
Wire Sizes	0.35-2.50 mm ²
Mating Terminals & Seals	TE Connectivity MCP Series. Sold separately.
Accessories	Optional: Cover tether, 30° angle bracket, 90° angle bracket

Mating Terminals and Seals Compatibility

Wire Size Range (mm ²)	Insulation Diameter (mm) FLR	Materials and Finish	Part Number Strip Form	TE Cable Seal Part Number	Cable Seal Color
0.35-0.50	1.2-1.4	1-xxx-1/1-xxx-3	968882	828904-1	Blue
0.5-1.0	1.4-2.1	1-xxx-1/1-xxx-2/1-xxx-3	968855	828904-2	Blue
1.0-2.5	2.2-3.0	1-xxx-1/1-xxx-3	968857	828905-1	White
Empty Cavity	—	—	Cable Seal Plug	828922-1	Natural

Sold separately. Available from TE Connectivity.

Dimensions in millimeters

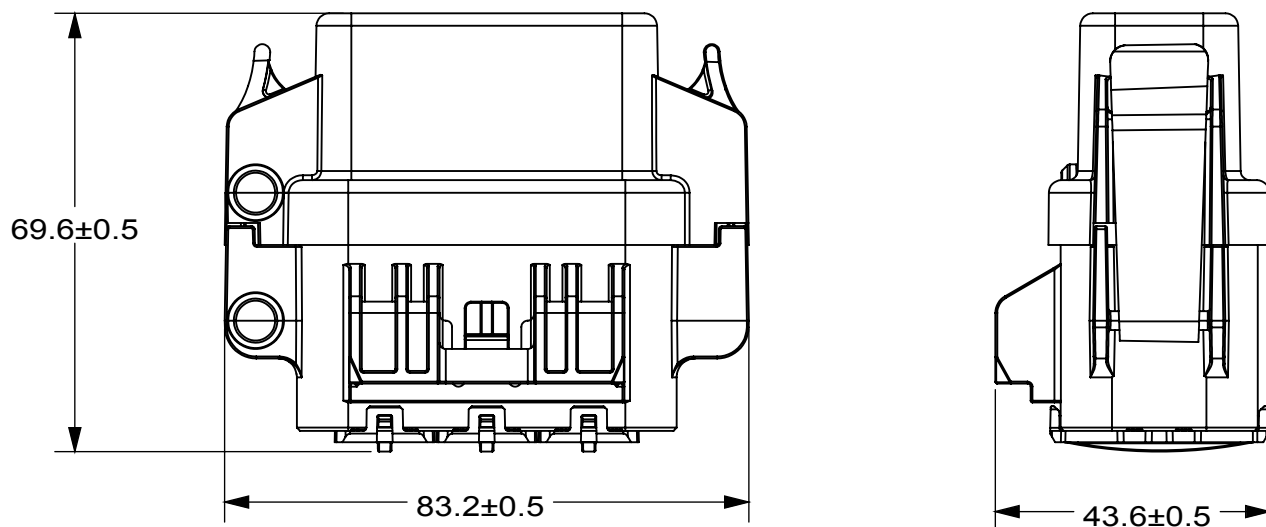

Visit Littelfuse.com for the most up-to-date product information. Littelfuse reserves the right to make product changes, without notice. Material in this document is as accurate as known at the time of publication.