



Chipsmall Limited consists of a professional team with an average of over 10 year of expertise in the distribution of electronic components. Based in Hongkong, we have already established firm and mutual-benefit business relationships with customers from,Europe,America and south Asia,supplying obsolete and hard-to-find components to meet their specific needs.

With the principle of “Quality Parts,Customers Priority,Honest Operation,and Considerate Service”,our business mainly focus on the distribution of electronic components. Line cards we deal with include Microchip,ALPS,ROHM,Xilinx,Pulse,ON,Everlight and Freescale. Main products comprise IC,Modules,Potentiometer,IC Socket,Relay,Connector.Our parts cover such applications as commercial,industrial, and automotives areas.

We are looking forward to setting up business relationship with you and hope to provide you with the best service and solution. Let us make a better world for our industry!



Contact us

Tel: +86-755-8981 8866 Fax: +86-755-8427 6832

Email & Skype: info@chipsmall.com Web: www.chipsmall.com

Address: A1208, Overseas Decoration Building, #122 Zhenhua RD., Futian, Shenzhen, China



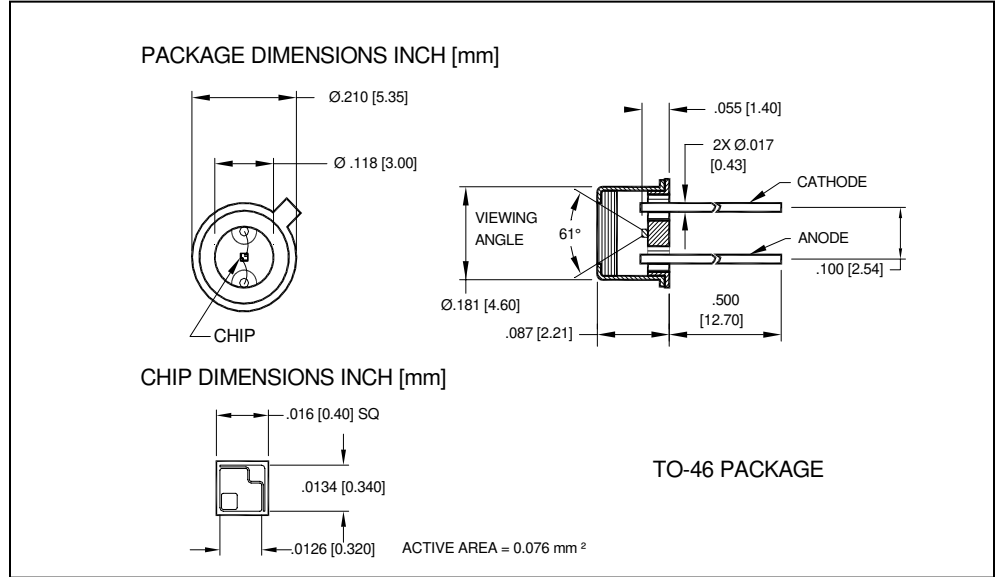

FEATURES

- 320nm UVB response
- Visible & NIR blind
- Photovoltaic operation
- High shunt resistance

DESCRIPTION

The **PDU-G102B** is a GaN UV photodiode with a spectral range from 200nm to 320nm and is ideal for UVB sensing applications available in a TO-46 can package.

APPLICATIONS

- UVB power meters
- Sun dosimeters
- UV epoxy curing
- UV instrumentation

ABSOLUTE MAXIMUM RATING (TA)= 23°C UNLESS OTHERWISE NOTED

SYMBOL	PARAMETER	MIN	MAX	UNITS
V _{BR}	Reverse Voltage		5	V
T _{STG}	Storage Temperature	-40	+90	°C
T _O	Operating Temperature	-30	+85	°C
T _S	Soldering Temperature*		+260	°C

* 1/16 inch from case for 3 seconds max.

SPECTRAL RESPONSE

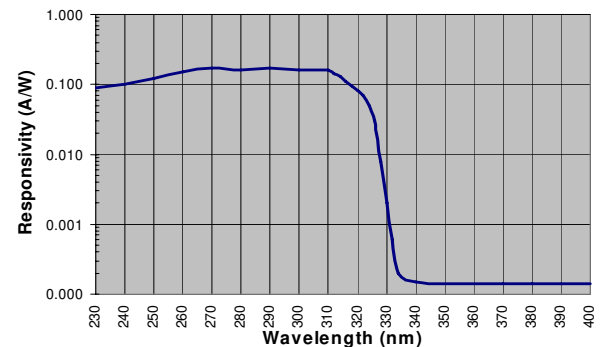

ELECTRO-OPTICAL CHARACTERISTICS RATING (TA)= 23°C UNLESS OTHERWISE NOTED

SYMBOL	CHARACTERISTIC	TEST CONDITIONS	MIN	TYP	MAX	UNITS
I _{SC}	Short Circuit Current	UVI = 1		1		nA
I _D	Dark Current	V _R = 1V		0.05	1	nA
R _{SH}	Shunt Resistance	V _R = 10 mV	0.45	1		GΩ
C _J	Junction Capacitance	V _R = 0V, f = 1 MHz		24		pF
λ _{range}	Spectral Application Range	Spot Scan	200		320	nm
R	Responsivity	λ = 350nm V, V _R = 0 V		0.10		A/W
V _{BR}	Breakdown Voltage	I = 1 μA		10		V
t _r	Response Time	RL = 1KΩ, V _R = 1V		10	15	nS

© 2007 Advanced Photonix, Inc. All rights reserved. Specifications and output data subject to change without notice.