



Chipsmall Limited consists of a professional team with an average of over 10 year of expertise in the distribution of electronic components. Based in Hongkong, we have already established firm and mutual-benefit business relationships with customers from,Europe,America and south Asia,supplying obsolete and hard-to-find components to meet their specific needs.

With the principle of “Quality Parts,Customers Priority,Honest Operation,and Considerate Service”,our business mainly focus on the distribution of electronic components. Line cards we deal with include Microchip,ALPS,ROHM,Xilinx,Pulse,ON,Everlight and Freescale. Main products comprise IC,Modules,Potentiometer,IC Socket,Relay,Connector.Our parts cover such applications as commercial,industrial, and automotives areas.

We are looking forward to setting up business relationship with you and hope to provide you with the best service and solution. Let us make a better world for our industry!



Contact us

Tel: +86-755-8981 8866 Fax: +86-755-8427 6832

Email & Skype: info@chipsmall.com Web: www.chipsmall.com

Address: A1208, Overseas Decoration Building, #122 Zhenhua RD., Futian, Shenzhen, China



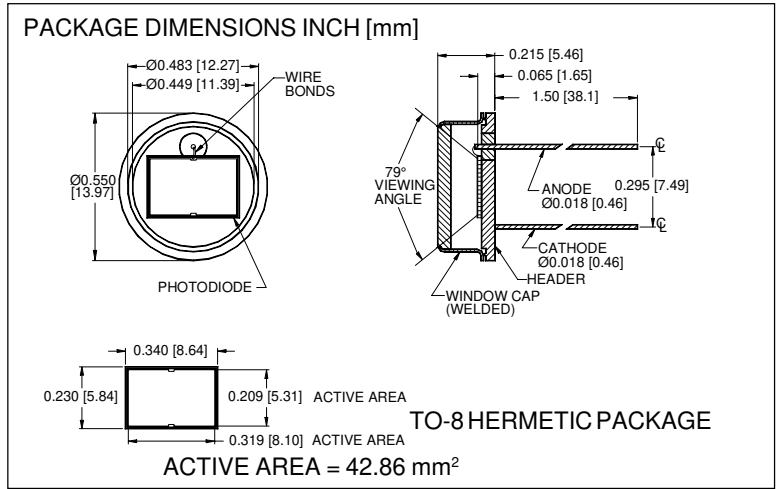

FEATURES

- Low noise
- U.V. enhanced
- High shunt resistance
- Quartz windows

DESCRIPTION

The **PDU-V109** is a silicon, PIN planar diffused, U.V. enhanced photodiode. Ideal for low noise photovoltaic applications. Packaged in a hermetic TO-8 metal can with a flat quartz window.

APPLICATIONS

- Spectrometers
- Fluorescent analysers
- U.V. meters
- Colorimeters

ABSOLUTE MAXIMUM RATING (TA=25°C unless otherwise noted)

SYMBOL	PARAMETER	MIN	MAX	UNITS
V _{BR}	Reverse Voltage		75	V
T _{STG}	Storage Temperature	-55	+150	°C
T _O	Operating Temperature Range	-40	+125	°C
T _S	Soldering Temperature*		+240	°C
I _L	Light Current		0.5	mA

*1/16 inch from case for 3 secs max

SPECTRAL RESPONSE

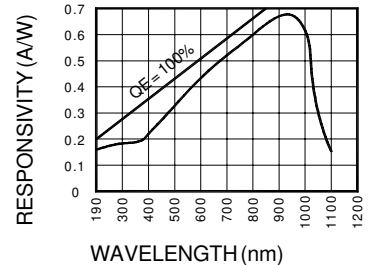

ELECTRO-OPTICAL CHARACTERISTICS (TA=25°C unless otherwise noted)

SYMBOL	CHARACTERISTIC	TEST CONDITIONS	MIN	TYP	MAX	UNITS
I _{SC}	Short Circuit Current	H = 100 fc, 2850 K	405	500		μA
I _D	Dark Current	H = 0, V _R = 10 mV		66	200	pA
R _{SH}	Shunt Resistance	H = 0, V _R = 10 mV	50	150		MΩ
TC R _{SH}	R _{SH} Temp. Coefficient	H = 0, V _R = 10 mV		-8		% / °C
C _J	Junction Capacitance	H = 0, V _R = 0 V**		4,500		pF
λ _{range}	Spectral Application Range	Spot Scan	190		1100	nm
R	Responsivity	V _R = 0 V, λ = 254 nm	.12	.18		A/W
V _{BR}	Breakdown Voltage	I = 10 μA	5	10		V
NEP	Noise Equivalent Power	V _R = 10 mV @ Peak		1.0x10 ⁻¹⁴		W/√Hz
tr	Response Time	RL = 1 KΩ V _R = 0 V		1,000		nS