



Chipsmall Limited consists of a professional team with an average of over 10 year of expertise in the distribution of electronic components. Based in Hongkong, we have already established firm and mutual-benefit business relationships with customers from,Europe,America and south Asia,supplying obsolete and hard-to-find components to meet their specific needs.

With the principle of “Quality Parts,Customers Priority,Honest Operation,and Considerate Service”,our business mainly focus on the distribution of electronic components. Line cards we deal with include Microchip,ALPS,ROHM,Xilinx,Pulse,ON,Everlight and Freescale. Main products comprise IC,Modules,Potentiometer,IC Socket,Relay,Connector.Our parts cover such applications as commercial,industrial, and automotives areas.

We are looking forward to setting up business relationship with you and hope to provide you with the best service and solution. Let us make a better world for our industry!



## Contact us

Tel: +86-755-8981 8866 Fax: +86-755-8427 6832

Email & Skype: info@chipsmall.com Web: www.chipsmall.com

Address: A1208, Overseas Decoration Building, #122 Zhenhua RD., Futian, Shenzhen, China



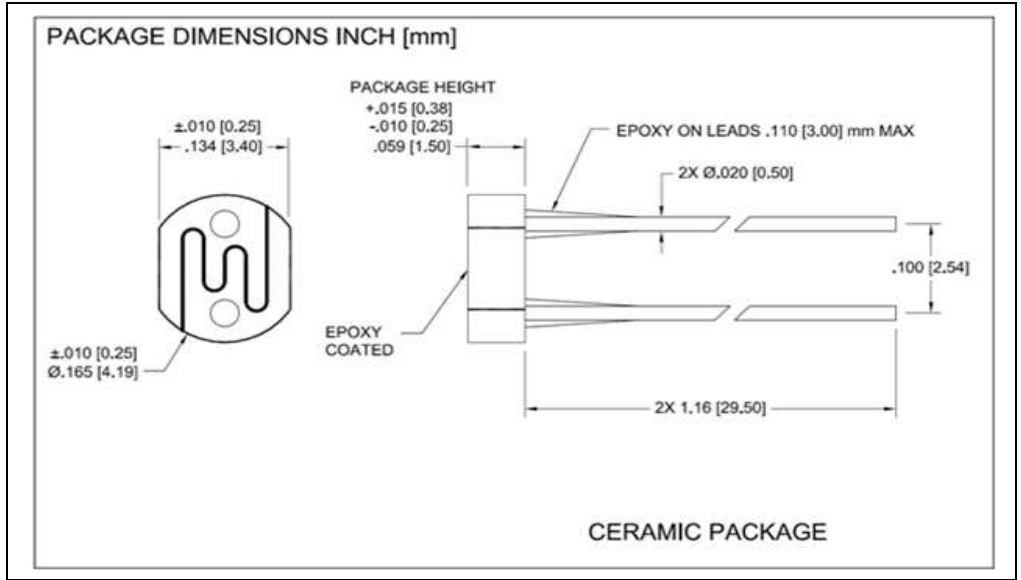

**DESCRIPTION**

The **PDV-P9103** are (CdS), Photoconductive photocells designed to sense light from 400 to 700 nm. These light dependent resistors are available in a wide range of resistance values. They're packaged in a two leaded plastic-coated ceramic header.

**FEATURES**

- Visible light response
- Sintered construction
- Low cost

**RELIABILITY**

This Luna high-reliability device is in principle able to meet military test requirements (Mil-STD-750, Mil-STD-883) after proper screening and group test. Contact Luna for recommendations on specific test conditions and procedures.

**APPLICATIONS**

- Camera exposure
- Shutter controls
- Night light controls

**ABSOLUTE MAXIMUM RATINGS**

SYMBOL	MIN		MAX	UNITS	(TA)= 23°C UNLESS OTHERWISE NOTED
Applied Voltage	-	-	150	V	-
Continuous Power Dissipation	-	-	90	mW/°C	-
Operation and Storage Temperature	-30	to	+75	V	-
Soldering Temperature*	-	-	+260	°C	-

\* 0.200 inch from base for 3 seconds with heat sink.

**OPTO-ELECTRICAL PARAMETERS**

T<sub>a</sub> = 23°C UNLESS NOTED OTHERWISE

PARAMETER	TEST CONDITIONS	MIN	TYP	MAX	UNITS
Dark Resistance	After 10 sec. @10 Lux @ 2856°K	1	-	-	MΩ
Illuminated Resistance	10 Lux @ 2856°K	20	-	45	KΩ
Sensitivity	$\frac{\text{Log}(R100) - \text{Log}(R10)}{\text{Log}(E100) - \text{Log}(E10)}$ ** ***	-	0.80	-	Ω/Lux
Spectral Application Range	Flooded	400	-	700	nm
Spectral Application Range	Flooded	-	570	-	nm
Rise Time	10 Lux @ 2856 °K	-	60	-	ms
Fall Time	After 10 Lux @ 2856 °K	-	25	-	ms

\*\*R100, R10: cell resistances at 100 Lux and 10 Lux at 2856 °K respectively .

\*\*\*E100, E10: luminances at 100 Lux and 10 Lux 2856 °K respectively.