



Chipsmall Limited consists of a professional team with an average of over 10 year of expertise in the distribution of electronic components. Based in Hongkong, we have already established firm and mutual-benefit business relationships with customers from,Europe,America and south Asia,supplying obsolete and hard-to-find components to meet their specific needs.

With the principle of “Quality Parts,Customers Priority,Honest Operation,and Considerate Service”,our business mainly focus on the distribution of electronic components. Line cards we deal with include Microchip,ALPS,ROHM,Xilinx,Pulse,ON,Everlight and Freescale. Main products comprise IC,Modules,Potentiometer,IC Socket,Relay,Connector.Our parts cover such applications as commercial,industrial, and automotives areas.

We are looking forward to setting up business relationship with you and hope to provide you with the best service and solution. Let us make a better world for our industry!



Contact us

Tel: +86-755-8981 8866 Fax: +86-755-8427 6832

Email & Skype: info@chipsmall.com Web: www.chipsmall.com

Address: A1208, Overseas Decoration Building, #122 Zhenhua RD., Futian, Shenzhen, China



This document contains confidential and proprietary information of Excelitas Technologies. The contents shall not be disclosed, reproduced, duplicated, disseminated or used for purposes other than authorized in writing by Excelitas Technologies

REVISIONS				
ZONE	REV.	DESCRIPTION	DATE	APPROVED
	A	REL/ECN 170504	12/03/09	K.TONG
	B	REV/ECN 172206	05/19/11	H.VOUNG

NOTES:

1. THIS DRAWING APPLIES TO MODEL NUMBER: PE300B-10FM
2. NOMINAL FOCAL DISTANCE FROM THE OUTER SURFACE OF WINDOW. WILL DECREASE OVER LIFE.
3. DIMENSIONS IN BRACKETS ARE IN MILLIMETERS.

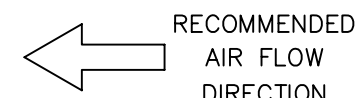
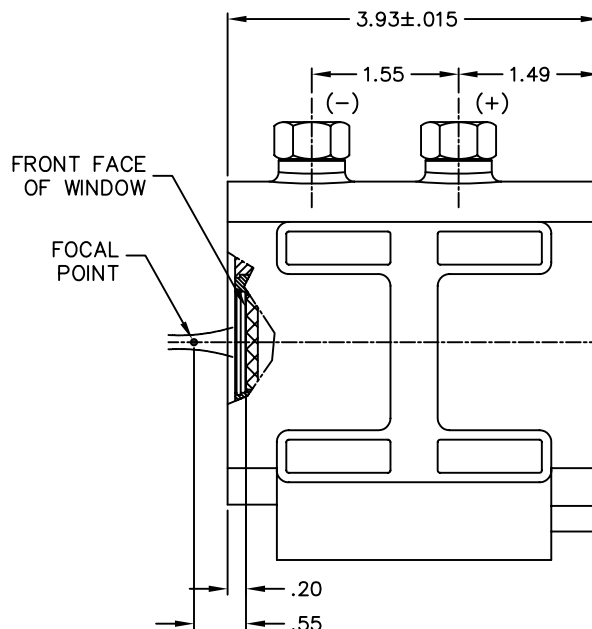
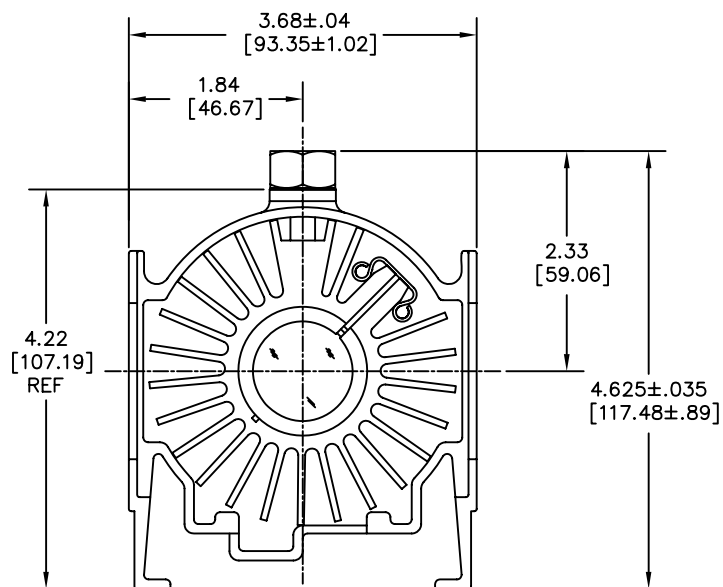
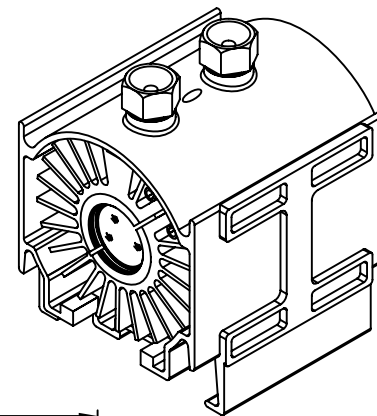

INTERFACE CONTROL DRAWING

UNLESS OTHERWISE SPECIFIED DIMENSIONS ARE IN INCHES TOLERANCES ARE: FRACTIONS ± 1/32 DECIMALS .006 ± .005 SURFACE ROUGHNESS: 125		CUSTOMER DOC NO.	APPROVALS	DATE	EXCELITAS TECHNOLOGIES 44370 Christy Street Fremont, CA 94538
MATERIAL:		ENGR. K.TONG	08/28/09	TITLE PE300B-10FM CERMAX LAMP MODULE	
FINISH:	GA	PROL. ENGR.			SIZE C
M & P		QA			CAGE CODE 31573
					DWG. NO. 231148
					SCALE NONE
					DO NOT SCALE DRAWING
					SHEET 1 OF 2

UNCONTROLLED COPY

PE300B-10FM
300 Watt Cermax® f/ 1.0 Module



Min Nominal Max Comments

1. Ignition Requirements

1.1	Peak Ignition Voltage at Lamp Terminals (kV)	23	-	35	Not to exceed 36kV for electrical safety
1.2	Ignition Pulse Width FWHM at Lamp Terminals (ns)	75	100	150	
1.3	Recommended Boost Voltage at Lamp Terminals (Volts)	180	210	240	
1.4	Boost Current at Lamp Terminals (Amps)	-	-	66	
1.5	Boost Circuit RC discharge time (ms)	0.75	1.0	1.5	
1.6	Boost Energy (Joules)	1.5	2.0	2.5	
1.7	Recommended discharge energy in ignition transformer 0.1 to 0.2 Joules.				
1.8	Main DC power supply to deliver operating current within RC discharge time of boost circuit.				
1.9	Ignition requirements applicable throughout lamp life.				

2. Electrical

2.1	Operating Power (Watts)	175	300	305	
2.2	Operating Current (Amps)	13.0	22.0	23.0	
2.3	Initial Lamp Voltage (Volts)	11.5	13.5	15.0	Voltage may change over lamp life
2.4	Ripple Current 0 - 1kHz (pk-pk %)	-	-	2	

3. Light Output / Performance at Nominal Power (initial only unless otherwise specified)

3.1	Spot Size at Focus - FWHM (inches)	-	.09	-	
3.2	Radiant Output (Watts)	-	65	-	
3.3	UV Output < 390nm (Watts)	-	3.3	-	
3.4	IR Output > 770nm (Watts)	-	32	-	
3.5	Total Visible Output 390 - 770nm when new (Lumens)	-	6900	-	
3.6	Total Visible Output 390 - 770nm @ 500 hours (Lumens)	-	3450	-	
3.7	Color Temperature (Kelvin)	-	5900	-	May decrease 5-10% over lamp life
3.8	Initial Focused Output into 6mm aperture (Lumens)	2400	3500	-	
3.9	Initial Focused Output into 3mm aperture (Lumens)	-	2000	-	
3.10	Peak instabilities 0 - 100Hz, integrated light when new (%)	-	4	6	As per Excelitas test method and equipment
3.11	Peak instabilities 0 - 100Hz, integrated light @ 1000 hours (%)	-	-	8	As per Excelitas test method and equipment

4. Mechanical & Environmental

4.1	Window Diameter (millimeters)	-	25.4	-	
4.2	Recommended Exit Air Flow (CFM)	35	45	-	
4.3	Operating Temperature at top center of ceramic (Celsius)	90	120	150	Max is at end of life
4.4	Storage Temperature (Celsius)	-40	-	70	
4.5	Ambient Starting Temperature (Celsius)	0	-	-	
4.6	Operating Humidity (% non-condensing)	-	-	85	
4.7	Weight (Grams)	-	750	-	
4.8	Recommended Environmental Operating Pressure (hPa)	300	1010	1050	hPa = hectopascals (Pascals x 100) = millibar
4.9	Operating Orientation (Degrees from horizontal)	-45	0	45	
4.10	Material composition for lamp module housing 20% glass filled nylon (UL94VO). Maximum recommended temperature is 100°C.				
4.11	Optical components used with lamp module should not impede air flow, nor should they reflect radiated energy back towards the lamp.				
4.12	Air flow and air inlet temperature should always ensure lamp temperature is kept within specification throughout lamp life.				
4.13	EMI characteristics may vary with operating hours and power. Adequate system precautions should be taken.				
4.14	Additional EMI may result when operated outside the recommended power range.				
4.15	Non-operating Shock and Vibration per ISTA1A.				

5. Warranty & Limitation of Excelitas Technologies Liability

5.1	Warranty Period : 12 months				
5.2	Warranty : 50% of initial 6mm lumens output minimum specification at 500 hours of continuous operation with no more than 1000 ignition cycles conditional on operation within specification limits & warranty period.				
5.3	Where no minimum or maximum value is specified, the value is nominal only and may vary.				
5.4	Excelitas assumes no responsibility for the suitability of this product for any particular application or any consequential damages associated with the use of this product.				
5.5	Specifications subject to change without notice.				