



Chipsmall Limited consists of a professional team with an average of over 10 year of expertise in the distribution of electronic components. Based in Hongkong, we have already established firm and mutual-benefit business relationships with customers from,Europe,America and south Asia,supplying obsolete and hard-to-find components to meet their specific needs.

With the principle of “Quality Parts,Customers Priority,Honest Operation,and Considerate Service”,our business mainly focus on the distribution of electronic components. Line cards we deal with include Microchip,ALPS,ROHM,Xilinx,Pulse,ON,Everlight and Freescale. Main products comprise IC,Modules,Potentiometer,IC Socket,Relay,Connector.Our parts cover such applications as commercial,industrial, and automotives areas.

We are looking forward to setting up business relationship with you and hope to provide you with the best service and solution. Let us make a better world for our industry!



## Contact us

Tel: +86-755-8981 8866 Fax: +86-755-8427 6832

Email & Skype: info@chipsmall.com Web: www.chipsmall.com

Address: A1208, Overseas Decoration Building, #122 Zhenhua RD., Futian, Shenzhen, China



# SEROCCO-H

## 2 Channel Serial Optimized Communication Controller for HDLC/PPP

PEB 20525 Version 1.2

PEF 20525 Version 1.2

Datacom



Never stop thinking.

**Edition 2000-09-14**

**Published by Infineon Technologies AG,  
St.-Martin-Strasse 53,  
D-81541 München, Germany**

**© Infineon Technologies AG 9/14/00.  
All Rights Reserved.**

### **Attention please!**

The information herein is given to describe certain components and shall not be considered as warranted characteristics.

Terms of delivery and rights to technical change reserved.

We hereby disclaim any and all warranties, including but not limited to warranties of non-infringement, regarding circuits, descriptions and charts stated herein.

Infineon Technologies is an approved CECC manufacturer.

### **Information**

For further information on technology, delivery terms and conditions and prices please contact your nearest Infineon Technologies Office in Germany or our Infineon Technologies Representatives worldwide (see address list).

### **Warnings**

Due to technical requirements components may contain dangerous substances. For information on the types in question please contact your nearest Infineon Technologies Office.

Infineon Technologies Components may only be used in life-support devices or systems with the express written approval of Infineon Technologies, if a failure of such components can reasonably be expected to cause the failure of that life-support device or system, or to affect the safety or effectiveness of that device or system. Life support devices or systems are intended to be implanted in the human body, or to support and/or maintain and sustain and/or protect human life. If they fail, it is reasonable to assume that the health of the user or other persons may be endangered.

# SEROCCO-H

2 Channel Serial Optimized  
Communication Controller for  
HDLC/PPP

PEB 20525 Version 1.2

PEF 20525 Version 1.2

Datacom



Never stop thinking.

**Revision History:**           **2000-09-14**

DS 1

Previous Version:           PASSAT V1.1 Preliminary Data Sheet, 09.99, DS2

---

Page (previous Version)	Page (current Version)	Subjects (major changes since last revision)
33-35	36-38	Correction: signal 'OSR' is multiplexed with signal 'CD', signal 'OST' is multiplexed with 'CTS' (was vice versa)
81	84	corrected HDLC receive address recognition table
n.a.	232, 235	Added timing diagram for external DMA support signals
n.a.	232	Added address timing diagram for Intel multiplexed mode (signal ALE)
222	226	Chapter "Electrical Characteristics" updated with final characterization results.

For questions on technology, delivery and prices please contact the Infineon Technologies Offices in Germany or the Infineon Technologies Companies and Representatives worldwide: see our webpage at <http://www.infineon.com>

<b>Table of Contents</b>		<b>Page</b>
<b>1</b>	<b>Introduction</b> .....	16
1.1	Features .....	17
1.2	Logic Symbol .....	20
1.3	Typical Applications .....	21
1.3.1	System Integration Example .....	21
1.3.2	Serial Configuration Examples .....	23
1.4	Differences between SEROCCO-H and the HSCX/ESCC Family .....	25
1.4.1	Enhancements to the HSCX Serial Core .....	25
1.4.2	Simplifications to the HSCX Serial Core .....	25
<b>2</b>	<b>Pin Descriptions</b> .....	26
2.1	Pin Diagram P-LFBGA-80-2 .....	26
2.2	Pin Diagram P-TQFP-100-3 .....	27
2.3	Pin Definitions and Functions .....	28
<b>3</b>	<b>Functional Overview</b> .....	42
3.1	Block Diagram .....	42
3.2	Serial Communication Controller (SCC) .....	43
3.2.1	Protocol Modes Overview .....	43
3.2.2	SCC FIFOs .....	43
3.2.2.1	SCC Transmit FIFO .....	43
3.2.2.2	SCC Receive FIFO .....	44
3.2.2.3	SCC FIFO Access .....	46
3.2.3	Clocking System .....	47
3.2.3.1	Clock Mode 0 (0a/0b) .....	51
3.2.3.2	Clock Mode 1 .....	52
3.2.3.3	Clock Mode 2 (2a/2b) .....	53
3.2.3.4	Clock Mode 3 (3a/3b) .....	54
3.2.3.5	Clock Mode 4 .....	55
3.2.3.6	Clock Mode 5a (Time Slot Mode) .....	56
3.2.3.7	Clock Mode 5b (Octet Sync Mode) .....	63
3.2.3.8	Clock Mode 6 (6a/6b) .....	66
3.2.3.9	Clock Mode 7 (7a/7b) .....	67
3.2.4	Baud Rate Generator (BRG) .....	68
3.2.5	Clock Recovery (DPLL) .....	68
3.2.6	SCC Timer Operation .....	71
3.2.7	SCC Serial Bus Configuration Mode .....	72
3.2.8	Serial Bus Access Procedure .....	72
3.2.9	Serial Bus Collisions and Recovery .....	72
3.2.10	Serial Bus Access Priority Scheme .....	73
3.2.11	Serial Bus Configuration Timing Modes .....	74
3.2.12	Functions Of Signal RTS in HDLC Mode .....	74
3.2.13	Data Encoding .....	74



<b>Table of Contents</b>		<b>Page</b>
3.2.13.1	NRZ and NRZI Encoding .....	75
3.2.13.2	FM0 and FM1 Encoding .....	75
3.2.13.3	Manchester Encoding .....	76
3.2.14	Modem Control Signals (RTS, CTS, CD) .....	77
3.2.14.1	RTS/CTS Handshaking .....	77
3.2.14.2	Carrier Detect (CD) Receiver Control .....	78
3.2.15	Local Loop Test Mode .....	78
3.3	Microprocessor Interface .....	79
3.4	External DMA Controller Support .....	80
3.5	Interrupt Architecture .....	81
3.6	General Purpose Port Pins .....	82
3.6.1	GPP Functional Description .....	82
3.6.2	GPP Interrupt Indication .....	82
<b>4</b>	<b>Detailed Protocol Description</b> .....	<b>83</b>
4.1	HDLC/SDLC Protocol Modes .....	83
4.1.0.1	Automode .....	84
4.1.0.2	Address Mode 2 .....	85
4.1.0.3	Address Mode 1 .....	85
4.1.0.4	Address Mode 0 .....	85
4.1.1	HDLC Receive Data Processing .....	85
4.1.2	Receive Address Handling .....	88
4.1.3	HDLC Transmit Data Processing .....	88
4.1.4	Shared Flags .....	90
4.1.5	One Bit Insertion .....	90
4.1.6	Preamble Transmission .....	90
4.1.7	CRC Generation and Checking .....	90
4.1.8	Receive Length Check Feature .....	91
4.2	Point-to-Point Protocol (PPP) Modes .....	92
4.2.1	Bit Synchronous PPP .....	92
4.2.2	Octet Synchronous PPP .....	92
4.2.3	Data Transparency in PPP Mode .....	93
4.3	Extended Transparent Mode .....	95
4.4	Procedural Support (Layer-2 Functions) .....	95
4.4.1	Full-Duplex LAPB/LAPD Operation .....	96
4.4.2	Half-Duplex SDLC-NRM Operation .....	101
4.4.3	Signaling System #7 (SS7) Operation .....	103
<b>5</b>	<b>Register Description</b> .....	<b>106</b>
5.1	Register Overview .....	106
5.2	Detailed Register Description .....	111
5.2.1	Global Registers .....	111
5.2.2	Channel Specific SCC Registers .....	128

<b>Table of Contents</b>		<b>Page</b>
5.2.3	Channel Specific DMA Registers .....	205
5.2.4	Miscellaneous Registers .....	212
<b>6</b>	<b>Programming</b> .....	<b>215</b>
6.1	Initialization .....	215
6.2	Interrupt Mode .....	215
6.2.1	Data Transmission (Interrupt Driven) .....	215
6.2.2	Data Reception (Interrupt Driven) .....	217
6.3	External DMA Supported Mode .....	219
6.3.1	Data Transmission (With External DMA Support) .....	219
6.3.2	Data Reception (With External DMA Support) .....	222
<b>7</b>	<b>Electrical Characteristics</b> .....	<b>226</b>
7.1	Absolute Maximum Ratings .....	226
7.2	Operating Range .....	226
7.3	DC Characteristics .....	227
7.4	AC Characteristics .....	228
7.5	Capacitances .....	228
7.6	Thermal Package Characteristics .....	229
7.7	Timing Diagrams .....	230
7.7.1	Microprocessor Interface Timing .....	230
7.7.1.1	Microprocessor Interface Clock Timing .....	230
7.7.1.2	Infineon/Intel Bus Interface Timing .....	231
7.7.1.3	Motorola Bus Interface Timing .....	234
7.7.2	PCM Serial Interface Timing .....	237
7.7.2.1	Clock Input Timing .....	237
7.7.2.2	Receive Cycle Timing .....	238
7.7.2.3	Transmit Cycle Timing .....	239
7.7.2.4	Clock Mode 1 Strobe Timing .....	241
7.7.2.5	Clock Mode 4 Gating Timing .....	242
7.7.2.6	Clock Mode 5 Frame Synchronisation Timing .....	243
7.7.3	Reset Timing .....	244
7.7.4	JTAG-Boundary Scan Timing .....	245
<b>8</b>	<b>Test Modes</b> .....	<b>246</b>
8.1	JTAG Boundary Scan Interface .....	246
<b>9</b>	<b>Package Outlines</b> .....	<b>251</b>



<b>List of Figures</b>		<b>Page</b>
Figure 1	Logic Symbol . . . . .	20
Figure 2	System Integration . . . . .	21
Figure 3	System Integration With External DMA Controller . . . . .	22
Figure 4	Point-to-Point Configuration . . . . .	23
Figure 5	Point-to-Multipoint Bus Configuration . . . . .	24
Figure 6	Multimaster Bus Configuration . . . . .	24
Figure 7	Pin Configuration P-LFBGA-80-2 Package . . . . .	26
Figure 8	Pin Configuration P-TQFP-100-3 Package . . . . .	27
Figure 9	Block Diagram . . . . .	42
Figure 10	SCC Transmit FIFO . . . . .	44
Figure 11	SCC Receive FIFO . . . . .	45
Figure 12	XFIFO/RFIFO Word Access (Intel Mode) . . . . .	46
Figure 13	XFIFO/RFIFO Word Access (Motorola Mode) . . . . .	46
Figure 14	Clock Supply Overview . . . . .	50
Figure 15	Clock Mode 0a/0b Configuration . . . . .	51
Figure 16	Clock Mode 1 Configuration . . . . .	52
Figure 17	Clock Mode 2a/2b Configuration . . . . .	53
Figure 18	Clock Mode 3a/3b Configuration . . . . .	54
Figure 19	Clock Mode 4 Configuration . . . . .	55
Figure 20	Selecting one time-slot of programmable delay and width . . . . .	57
Figure 21	Selecting one or more time-slots of 8-bit width . . . . .	59
Figure 22	Clock Mode 5a Configuration . . . . .	60
Figure 23	Clock Mode 5a "Continuous Mode" . . . . .	61
Figure 24	Clock Mode 5a "Non Continuous Mode" . . . . .	62
Figure 25	Selecting one or more octet wide time-slots . . . . .	64
Figure 26	Clock Mode 5b Configuration . . . . .	65
Figure 27	Clock Mode 6a/6b Configuration . . . . .	66
Figure 28	Clock Mode 7a/7b Configuration . . . . .	67
Figure 29	DPLL Algorithm (NRZ and NRZI Encoding, Phase Shift Enabled) . . . . .	70
Figure 30	DPLL Algorithm (NRZ and NRZI Encoding, Phase Shift Disabled) . . . . .	70
Figure 31	DPLL Algorithm for FM0, FM1 and Manchester Encoding . . . . .	71
Figure 32	Request-to-Send in Bus Operation . . . . .	74
Figure 33	NRZ and NRZI Data Encoding . . . . .	75
Figure 34	FM0 and FM1 Data Encoding . . . . .	76
Figure 35	Manchester Data Encoding . . . . .	76
Figure 36	RTS/CTS Handshaking . . . . .	78
Figure 37	SCC Test Loop . . . . .	79
Figure 38	Interrupt Status Registers . . . . .	81
Figure 39	HDLC Receive Data Processing in 16 bit Automode . . . . .	86
Figure 40	HDLC Receive Data Processing in 8 bit Automode . . . . .	86
Figure 41	HDLC Receive Data Processing in Address Mode 2 (16 bit) . . . . .	86
Figure 42	HDLC Receive Data Processing in Address Mode 2 (8 bit) . . . . .	87

<b>List of Figures</b>	<b>Page</b>
Figure 43	HDLC Receive Data Processing in Address Mode 1 . . . . . 87
Figure 44	HDLC Receive Data Processing in Address Mode 0 . . . . . 87
Figure 45	SCC Transmit Data Flow (HDLC Modes) . . . . . 89
Figure 46	PPP Mapping/Unmapping Example. . . . . 94
Figure 47	Processing of Received Frames in Auto Mode . . . . . 97
Figure 48	Timer Procedure/Poll Cycle . . . . . 99
Figure 49	Transmission/Reception of I-Frames and Flow Control. . . . . 100
Figure 50	Flow Control: Reception of S-Commands and Protocol Errors . . . . . 100
Figure 51	No Data to Send: Data Reception/Transmission . . . . . 103
Figure 52	Data Transmission (without error), Data Transmission (with error) . . 103
Figure 53	Interrupt Driven Data Transmission (Flow Diagram) . . . . . 216
Figure 54	Interrupt Driven Data Reception (Flow Diagram) . . . . . 218
Figure 55	DMA Transmit (Single Buffer per Packet) . . . . . 220
Figure 56	Fragmented DMA Transmission (Multiple Buffers per Packet) . . . . . 221
Figure 57	DMA Receive (Single Buffer per Packet) . . . . . 223
Figure 58	Fragmented Reception per DMA (Example) . . . . . 224
Figure 59	Fragmented Reception Sequence (Example) . . . . . 225
Figure 60	Input/Output Waveform for AC Tests . . . . . 228
Figure 61	Microprocessor Interface Clock Timing . . . . . 230
Figure 62	Infineon/Intel Read Cycle Timing . . . . . 231
Figure 63	Infineon/Intel Write Cycle Timing . . . . . 231
Figure 64	Infineon/Intel DMA Read Cycle Timing . . . . . 232
Figure 65	Infineon/Intel DMA Write Cycle Timing . . . . . 232
Figure 66	Infineon/Intel Multiplexed Address Timing . . . . . 232
Figure 67	Motorola Read Cycle Timing . . . . . 234
Figure 68	Motorola Write Cycle Timing . . . . . 234
Figure 69	Motorola DMA Read Cycle Timing . . . . . 235
Figure 70	Motorola DMA Write Cycle Timing . . . . . 235
Figure 71	Clock Input Timing . . . . . 237
Figure 72	Receive Cycle Timing . . . . . 238
Figure 73	Transmit Cycle Timing . . . . . 239
Figure 74	Clock Mode 1 Strobe Timing . . . . . 241
Figure 75	Clock Mode 4 Receive Gating Timing . . . . . 242
Figure 76	Clock Mode 4 Transmit Gating Timing . . . . . 242
Figure 77	Clock Mode 5 Frame Synchronisation Timing . . . . . 243
Figure 78	Reset Timing . . . . . 244
Figure 79	JTAG-Boundary Scan Timing . . . . . 245
Figure 80	Block Diagram of Test Access Port and Boundary Scan Unit . . . . . 246

<b>List of Tables</b>		<b>Page</b>
Table 1	Microprocessor Bus Interface .....	28
Table 2	External DMA Interface .....	33
Table 3	Serial Port Pins .....	35
Table 4	General Purpose Pins .....	39
Table 5	Test Interface Pins .....	40
Table 6	Power Pins .....	41
Table 7	Overview of Clock Modes .....	47
Table 8	Clock Modes of the SCCs .....	48
Table 9	BRRL/BRRH Register and Bit-Fields .....	68
Table 10	Data Bus Access 16-bit Intel Mode .....	80
Table 11	Data Bus Access 16-bit Motorola Mode .....	80
Table 12	Protocol Mode Overview .....	83
Table 13	Address Comparison Overview .....	84
Table 14	Error Handling .....	101
Table 15	Register Overview .....	106
Table 16	Status Information after RME interrupt .....	217
Table 17	DMA Terminology .....	219
Table 18	Capacitances TA = 25 °C; VDD3 = 3.3 V ± 0.3 V, VSS = 0 V .....	228
Table 19	Thermal Package Characteristics P-TQFP-100-3 .....	229
Table 20	Thermal Package Characteristics P-LFBGA-80-2 .....	229
Table 21	Microprocessor Interface Clock Timing .....	230
Table 22	Infineon/Intel Bus Interface Timing .....	233
Table 23	Motorola Bus Interface Timing .....	235
Table 24	Clock Input Timing .....	237
Table 25	Receive Cycle Timing .....	238
Table 26	Transmit Cycle Timing .....	240
Table 27	Clock Mode 1 Strobe Timing .....	241
Table 28	Clock Mode 4 Gating Timing .....	242
Table 29	Clock Mode 5 Frame Synchronisation Timing .....	243
Table 30	Reset Timing .....	244
Table 31	JTAG-Boundary Scan Timing .....	245
Table 32	Boundary Scan Sequence of SEROCCO-H .....	247
Table 33	Boundary Scan Test Modes .....	250

<b>List of Registers</b>		<b>Page</b>
Register 1	GCMDR .....	111
Register 2	GMODE .....	112
Register 3	GSTAR .....	114
Register 4	GPDIRL .....	116
Register 5	GPDIRH .....	116
Register 6	GPDATL .....	118
Register 7	GPDATA .....	118
Register 8	GPIML .....	120
Register 9	GPIMH .....	120
Register 10	GPISL .....	122
Register 11	GPISH .....	122
Register 12	DCMDR .....	124
Register 13	DISR .....	125
Register 14	DIMR .....	127
Register 15	FIFOL .....	128
Register 16	FIFOH .....	128
Register 17	STARL .....	131
Register 18	STARH .....	131
Register 19	CMDRL .....	135
Register 20	CMDRH .....	135
Register 21	CCR0L .....	139
Register 22	CCR0H .....	139
Register 23	CCR1L .....	143
Register 24	CCR1H .....	143
Register 25	CCR2L .....	148
Register 26	CCR2H .....	148
Register 27	CCR3L .....	153
Register 28	CCR3H .....	153
Register 29	PREAMB .....	157
Register 30	ACCM0 .....	158
Register 31	ACCM1 .....	158
Register 32	ACCM2 .....	159
Register 33	ACCM3 .....	159
Register 34	UDAC0 .....	161
Register 35	UDAC1 .....	161
Register 36	UDAC2 .....	162
Register 37	UDAC3 .....	162
Register 38	T TSA0 .....	164
Register 39	T TSA1 .....	164
Register 40	T TSA2 .....	165
Register 41	T TSA3 .....	165
Register 42	RTSA0 .....	167

<b>List of Registers</b>		<b>Page</b>
Register 43	RTSA1 .....	167
Register 44	RTSA2 .....	168
Register 45	RTSA3 .....	168
Register 46	PCMTX0 .....	170
Register 47	PCMTX1 .....	170
Register 48	PCMTX2 .....	171
Register 49	PCMTX3 .....	171
Register 50	PCMRX0 .....	173
Register 51	PCMRX1 .....	173
Register 52	PCMRX2 .....	174
Register 53	PCMRX3 .....	174
Register 54	BRRL .....	176
Register 55	BRRH .....	176
Register 56	TIMR0 .....	178
Register 57	TIMR1 .....	178
Register 58	TIMR2 .....	179
Register 59	TIMR3 .....	179
Register 60	XAD1 .....	182
Register 61	XAD2 .....	182
Register 62	RAL1 .....	184
Register 63	RAH1 .....	184
Register 64	RAL2 .....	185
Register 65	RAH2 .....	185
Register 66	AMRAL1 .....	187
Register 67	AMRAH1 .....	187
Register 68	AMRAL2 .....	188
Register 69	AMRAH2 .....	188
Register 70	RLCRL .....	190
Register 71	RLCRH .....	190
Register 72	ISR0 .....	192
Register 73	ISR1 .....	192
Register 74	ISR2 .....	193
Register 75	IMR0 .....	198
Register 76	IMR1 .....	198
Register 77	IMR2 .....	199
Register 78	RSTA .....	201
Register 79	XBCL .....	206
Register 80	XBCH .....	206
Register 81	RMBSL .....	208
Register 82	RMBSH .....	208
Register 83	RBCL .....	210
Register 84	RBCH .....	210

**List of Registers**

**Page**

Register 85	VER0 .....	212
Register 86	VER1 .....	212
Register 87	VER2 .....	213
Register 88	VER3 .....	213



## Preface

The 2 Channel Serial Optimized Communication Controller for HDLC/PPP PEB 20525 (SEROCCO-H) is a Protocol Controller for a wide range of data communication and telecommunication applications. This document provides complete reference information on hardware and software related issues as well as on general operation.

### Organization of this Document

This Data Sheet is divided into 9 chapters. It is organized as follows:

- **Chapter 1, Introduction**  
Gives a general description of the product, lists the key features, and presents some typical applications.
- **Chapter 2, Pin Descriptions**  
Lists pin locations with associated signals, categorizes signals according to function, and describes signals.
- **Chapter 3, Functional Overview**  
This chapter provides detailed descriptions of all SEROCCO-H internal functional blocks.
- **Chapter 4, Detailed Protocol Description**  
Gives a detailed description of all protocols supported by the serial communication controllers SCCs.
- **Chapter 5, Register Description**  
Gives a detailed description of all SEROCCO-H on chip registers.
- **Chapter 6, Programming**  
Provides programming help for SEROCCO-H initialization procedure and operation.
- **Chapter 7, Electrical Characteristics**  
Gives a detailed description of all electrical DC and AC characteristics and provides timing diagrams and values for all interfaces.
- **Chapter 8, Test Modes**  
Gives a detailed description of the JTAG boundary scan unit.
- **Chapter 9, Package Outlines**

## **Your Comments**

We welcome your comments on this document. We are continuously trying improving our documentation. Please send your remarks and suggestions by e-mail to

sc.docu\_comments@infineon.com

Please provide in the *subject* of your e-mail:

device name (SEROCCO-H), device number (PEB 20525, PEF 20525), device version (Version 1.2),

and in the *body* of your e-mail:

document type (Data Sheet), issue date (2000-09-14) and document revision number (DS 1).

## **1 Introduction**

The SEROCCO-H is a Serial Communication Controller with two independent serial channels<sup>1)</sup>. The serial channels are derived from updated protocol logic of the ESCC and DSCC4 device family providing a large set of protocol support and variety in serial interface configuration. This allows easy integration to different environments and applications.

A generic 8- or 16-bit multiplexed/demultiplexed slave interface provides fast device access with low bus utilization and easy software handshaking (in the P-LFBGA-80-2 package only an 8-bit data bus is provided). DMA handshake control signals allow connection to an external DMA controller.

Large on-chip FIFOs of 64 byte capacity per port and direction in combination with enhanced threshold control mechanisms allow decoupling of traffic requirements on host bus and serial interfaces with little exception probabilities such as data underruns or overflows.

Each of the two Serial Communication Controllers (SCC) contains an independent Baud Rate Generator, DPLL and programmable protocol processing (HDLC, PPP). Data rates of up to 12.5 Mbit/s (2 Mbit/s in DPLL assisted modes) are supported. The channels can also handle a large set of layer-2 protocol functions (LAPD, SS7) reducing bus and host CPU load. Two channel specific timers are provided to support protocol functions.

---

<sup>1)</sup> The serial channels are also called 'ports' or 'cores' depending on the context.

# 2 Channel Serial Optimized Communication Controller for HDLC/PPP SEROCCO-H

PEB 20525  
PEF 20525

Version 1.2

CMOS

## 1.1 Features

### Serial communication controllers (SCCs)

- Two independent channels
- Full duplex data rates on each channel of up to 12.5 Mbit/s sync - 2 Mbit/s with DPLL
- 64 Bytes deep receive FIFO per SCC
- 64 Bytes deep transmit FIFO per SCC

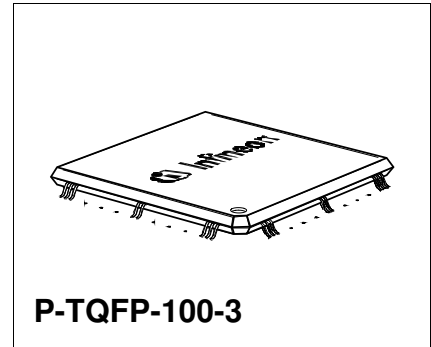

### Serial Interface

- On-chip clock generation or external clock sources
- On-chip DPLLs for clock recovery
- Baud rate generator
- Clock gating signals
- Clock gapping capability
- Programmable time-slot capability for connection to TDM interfaces (e.g. T1, E1)
- NRZ, NRZI, FM and Manchester data encoding
- Optional data flow control using modem control lines ( $\overline{RTS}$ ,  $\overline{CTS}$ , CD)
- Support of bus configuration by collision detection and resolution

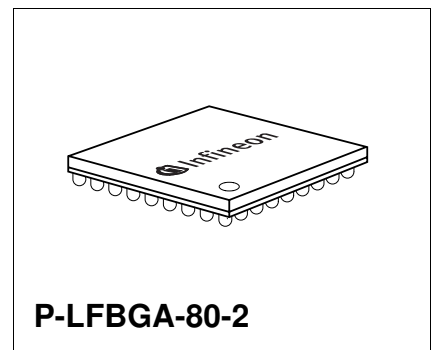

### Bit Processor Functions

- HDLC/SDLC Protocol Modes
  - Automatic flag detection and transmission
  - Shared opening and closing flag
  - Generation of interframe-time fill '1's or flags
  - Detection of receive line status
  - Zero bit insertion and deletion

Type	Package
PEB 20525, PEF 20525	P-TQFP-100-3
	P-LFBGA-80-2

- CRC generation and checking (CRC-CCITT or CRC-32)
- Transparent CRC option per channel and/or per frame
- Programmable Preamble (8 bit) with selectable repetition rate
- Error detection (abort, long frame, CRC error, short frames)
- Bit Synchronous PPP Mode
  - Bit oriented transmission of HDLC frame (flag, data, CRC, flag)
  - Zero bit insertion/deletion
  - 15 consecutive '1' bits abort sequence
- Octet Synchronous PPP Mode
  - Octet oriented transmission of HDLC frame (flag, data, CRC, flag)
  - Programmable character map of 32 hard-wired characters (00<sub>H</sub>-1F<sub>H</sub>)
  - Four programmable characters for additional mapping
  - Insertion/deletion of control-escape character (7D<sub>H</sub>) for mapped characters
- Extended Transparent Mode
  - Fully bit transparent (no framing, no bit manipulation)
  - Octet-aligned transmission and reception
- Protocol and Mode Independent
  - Data bit inversion
  - Data overflow and underrun detection
  - Timer

## Protocol Support

- Address Recognition Modes
  - No address recognition (Address Mode 0)
  - 8-bit (high byte) address recognition (Address Mode 1)
  - 8-bit (low byte) or 16-bit (high and low byte) address recognition (Address Mode 2)
- HDLC Automode
  - 8-bit or 16-bit address generation/recognition
  - Support of LAPB/LAPD
  - Automatic handling of S- and I-frames
  - Automatic processing of control byte(s)
  - Modulo-8 or modulo-128 operation
  - Programmable time-out and retry conditions
  - SDLC Normal Response Mode (NRM) operation for slave
- Signaling System #7 (SS7) support
  - Detection of FISUs, MSUs and LSSUs
  - Unchanged Fill-In Signaling Units (FISUs) not forwarded
  - Automatic generation of FISUs in transmit direction (incl. sequence number)
  - Counting of errored signaling units
- Optional  $\overline{DTACK}/\overline{READY}$  controlled cycles

### Microprocessor Interface

- 8-bit bus interface (P-LFBGA-80-2 package)
- 8/16-bit bus interface (P-TQFP-100-3 package)
- Multiplexed and De-multiplexed address/data bus
- Intel/Motorola style
- Asynchronous interface
- Maskable interrupts for each channel

### General Purpose Port (GPP) Pins (up to 3 in P-LFBGA-80-2, up to 7 in P-TQFP-100-3 package)

#### General

- 3.3V power supply with 5V tolerant inputs
- Low power consumption
- Power safe features
- P-TQFP-100-3 Package (Thermal Resistance:  $R_{JA} = 42 \text{ K/W}$ )
- Small P-LFBGA-80-2 Package (Thermal Resistance:  $R_{JA} = 51 \text{ K/W}$ )



## 1.2 Logic Symbol

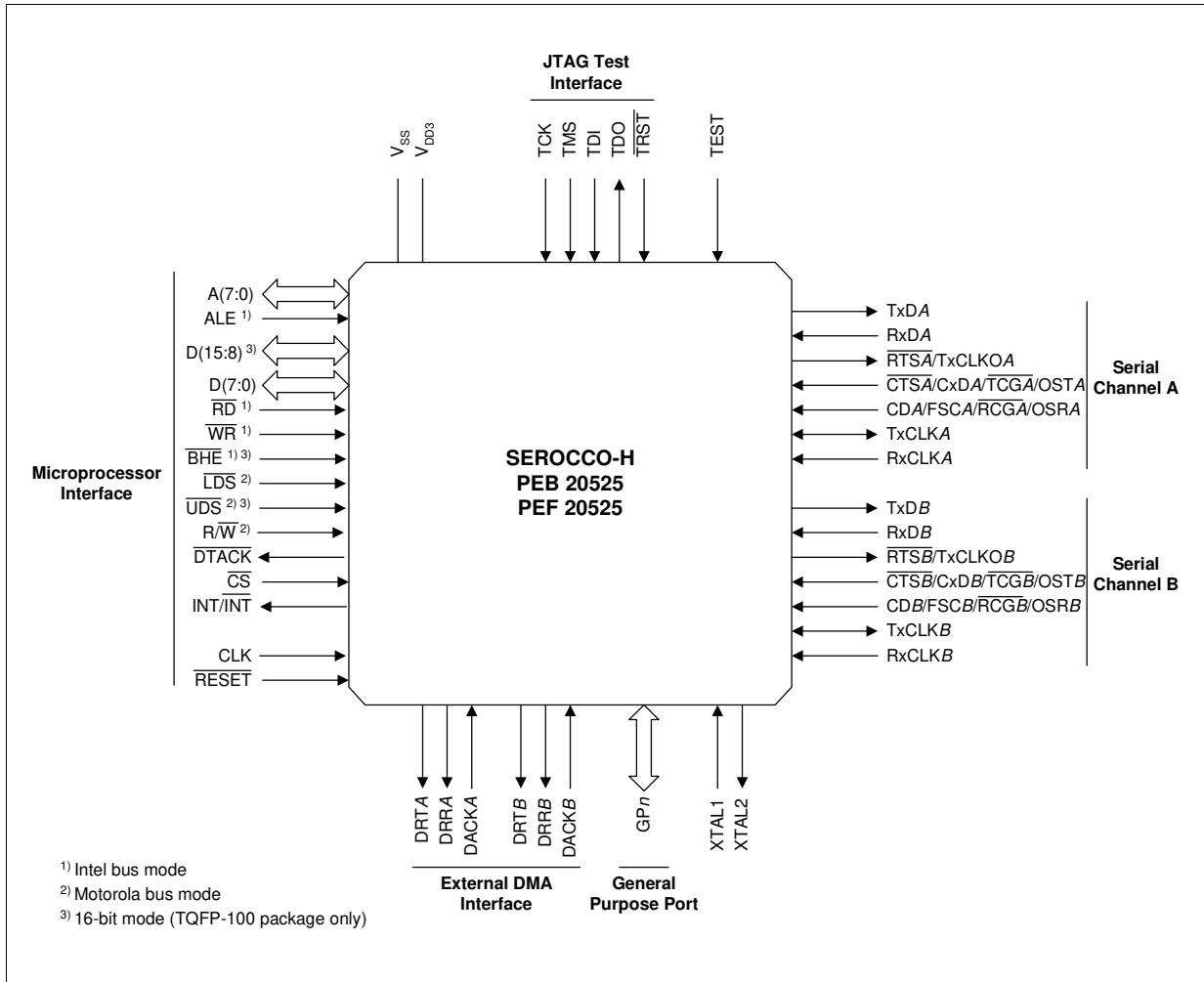

Figure 1 Logic Symbol

### 1.3 Typical Applications

SEROCCO-H devices can be used in LAN-WAN inter-networking applications such as Routers, Switches and Trunk cards and support the common V.35, ISDN BRI (S/T) and RFC1662 standards. Its new features provide powerful hardware and software interfaces to develop high performance systems.

#### 1.3.1 System Integration Example

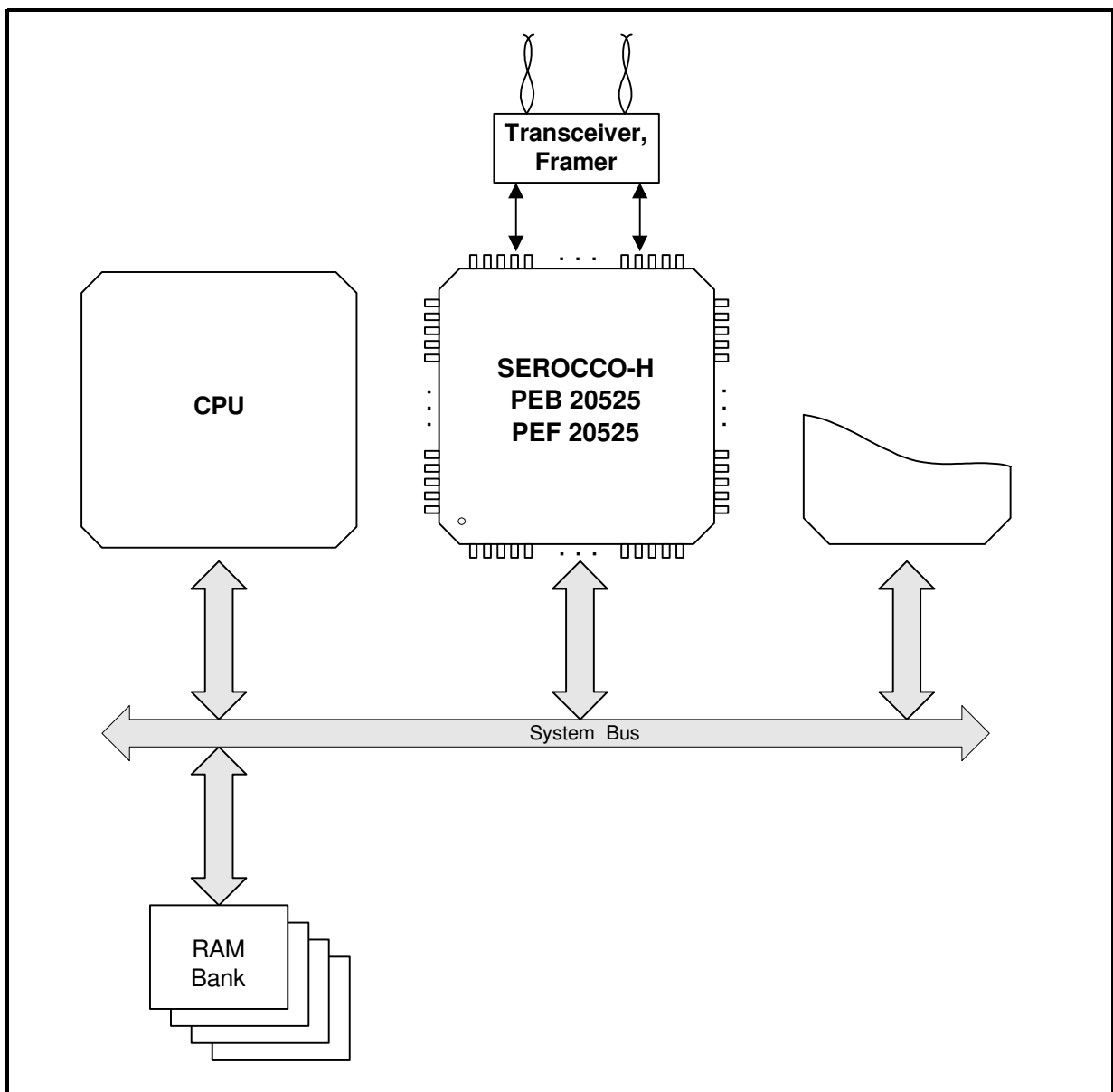
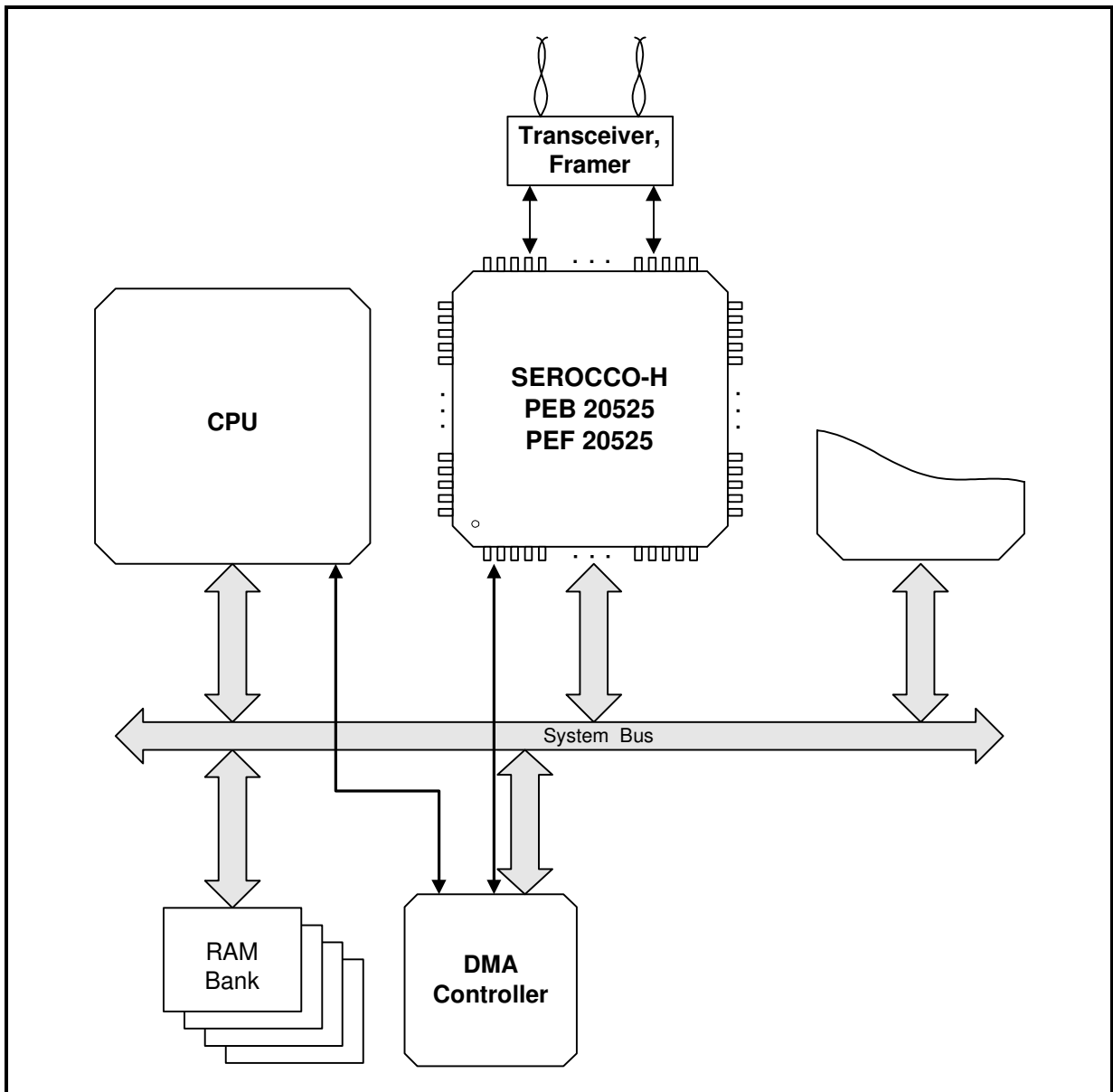

Figure 2 System Integration



**Figure 3 System Integration With External DMA Controller**

### 1.3.2 Serial Configuration Examples

SEROCCO-H supports a variety of serial configurations at Layer-1 and Layer-2 level. The outstanding variety of clock modes supporting a large number of combinations of external and internal clock sources allows easy integration in application environments.

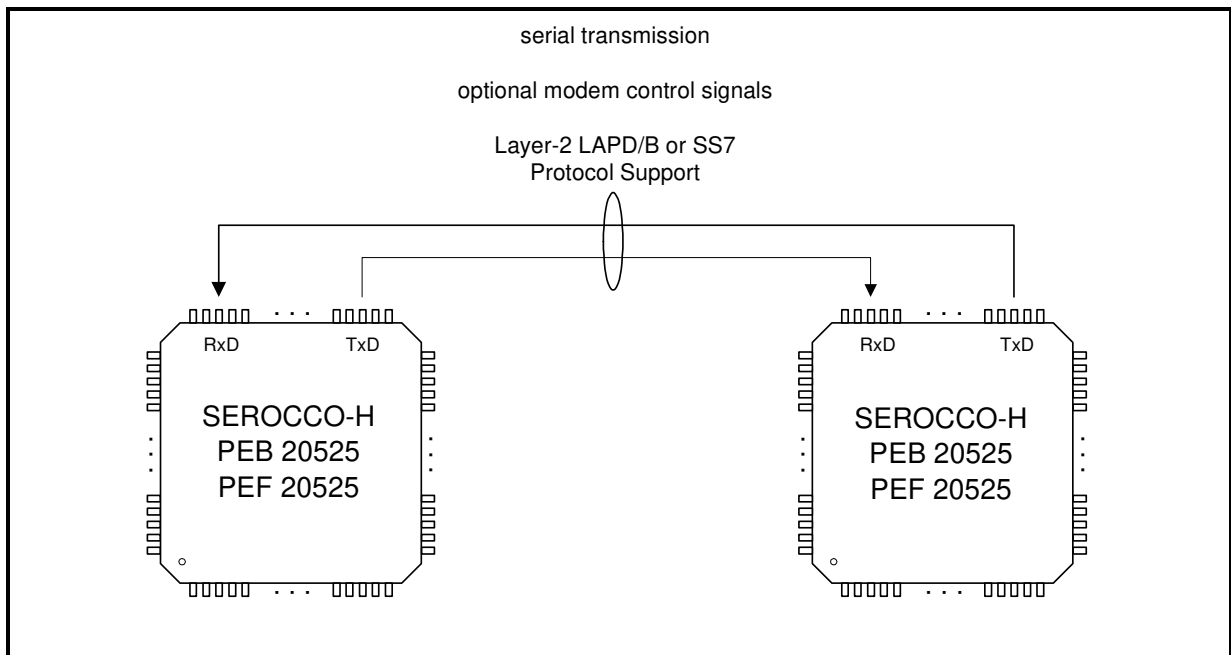

Figure 4 Point-to-Point Configuration

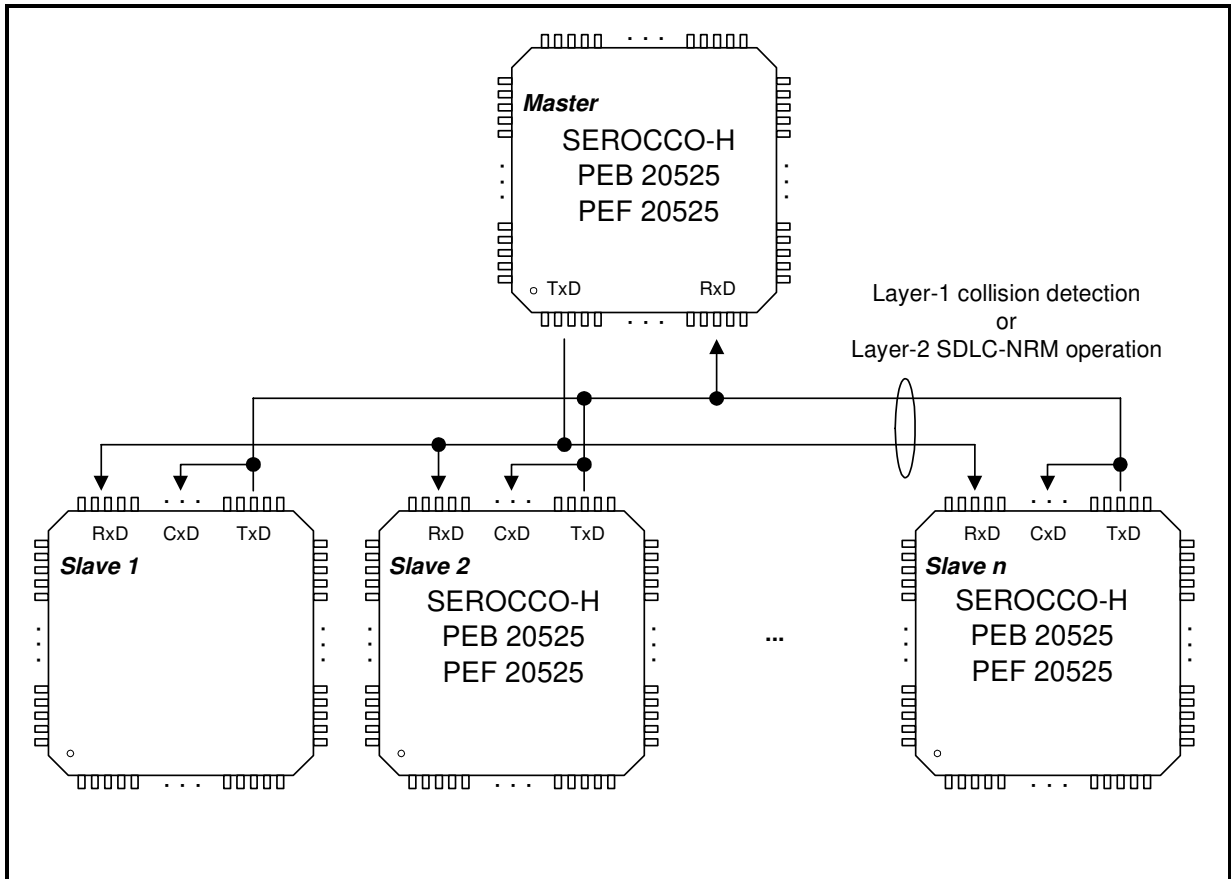

Figure 5 Point-to-Multipoint Bus Configuration

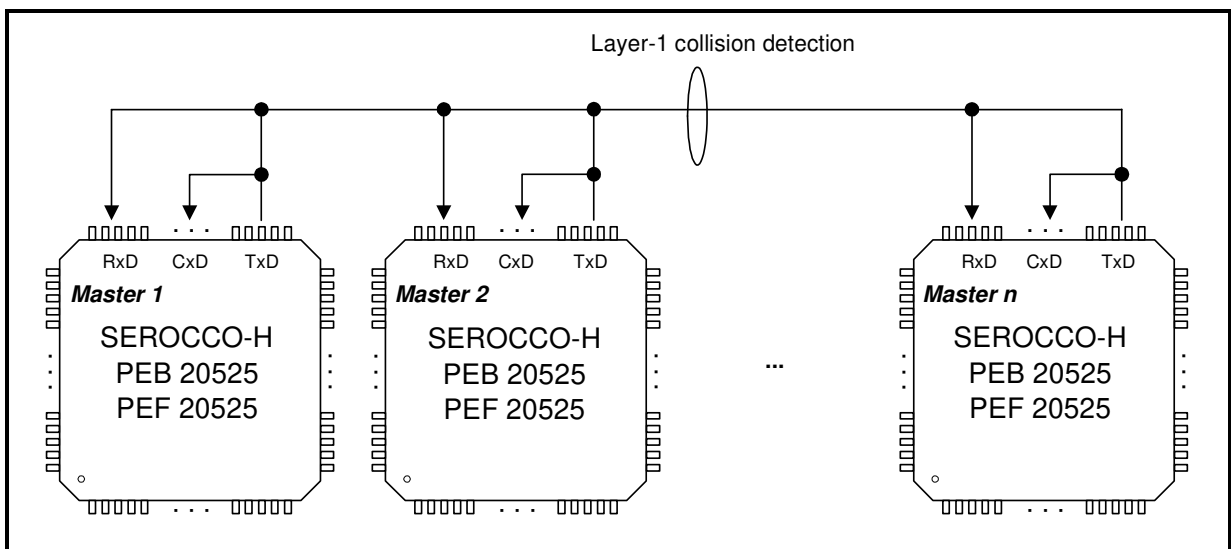

Figure 6 Multimaster Bus Configuration

## 1.4 Differences between SEROCCO-H and the HSCX/ESCC Family

This chapter is useful for all being familiar with the HSCX/ESCC family.

### 1.4.1 Enhancements to the HSCX Serial Core

The SEROCCO-H SCC cores contain the core logic of the HSCX as the heart of the device. Some enhancements are incorporated in the SCCs. These are:

- Octet-and Bit Synchronous PPP protocol support as in RFC-1662
- Signaling System #7 (SS7) support
- 4-kByte packet length byte counter
- Enhanced address filtering (16-bit maskable)
- Enhanced time slot assigner
- Support of high data rates (12.5 Mbit/s)

### 1.4.2 Simplifications to the HSCX Serial Core

The following features of the HSCX core have been removed:

- Extended transparent mode 0  
(this mode provided octet buffered data reception without usage of FIFOs; SEROCCO-H supports octet buffered reception via appropriate threshold configurations for the SCC receive FIFOs)
- Master clock mode