



Chipsmall Limited consists of a professional team with an average of over 10 year of expertise in the distribution of electronic components. Based in Hongkong, we have already established firm and mutual-benefit business relationships with customers from,Europe,America and south Asia,supplying obsolete and hard-to-find components to meet their specific needs.

With the principle of “Quality Parts,Customers Priority,Honest Operation,and Considerate Service”,our business mainly focus on the distribution of electronic components. Line cards we deal with include Microchip,ALPS,ROHM,Xilinx,Pulse,ON,Everlight and Freescale. Main products comprise IC,Modules,Potentiometer,IC Socket,Relay,Connector.Our parts cover such applications as commercial,industrial, and automotives areas.

We are looking forward to setting up business relationship with you and hope to provide you with the best service and solution. Let us make a better world for our industry!



## Contact us

Tel: +86-755-8981 8866 Fax: +86-755-8427 6832

Email & Skype: info@chipsmall.com Web: www.chipsmall.com

Address: A1208, Overseas Decoration Building, #122 Zhenhua RD., Futian, Shenzhen, China



# SEROCCO-D

2 Channel Serial Optimized  
Communication Controller with  
DMA

PEB 20542 Version 1.2

PEF 20542 Version 1.2

Datacom



Never stop thinking.

**Edition 2000-09-14**

**Published by Infineon Technologies AG,  
St.-Martin-Strasse 53,  
D-81541 München, Germany**

**© Infineon Technologies AG 9/14/00.  
All Rights Reserved.**

**Attention please!**

The information herein is given to describe certain components and shall not be considered as warranted characteristics.

Terms of delivery and rights to technical change reserved.

We hereby disclaim any and all warranties, including but not limited to warranties of non-infringement, regarding circuits, descriptions and charts stated herein.

Infineon Technologies is an approved CECC manufacturer.

**Information**

For further information on technology, delivery terms and conditions and prices please contact your nearest Infineon Technologies Office in Germany or our Infineon Technologies Representatives worldwide (see address list).

**Warnings**

Due to technical requirements components may contain dangerous substances. For information on the types in question please contact your nearest Infineon Technologies Office.

Infineon Technologies Components may only be used in life-support devices or systems with the express written approval of Infineon Technologies, if a failure of such components can reasonably be expected to cause the failure of that life-support device or system, or to affect the safety or effectiveness of that device or system. Life support devices or systems are intended to be implanted in the human body, or to support and/or maintain and sustain and/or protect human life. If they fail, it is reasonable to assume that the health of the user or other persons may be endangered.

# SEROCCO-D

2 Channel Serial Optimized  
Communication Controller with  
DMA

PEB 20542 Version 1.2

PEF 20542 Version 1.2

Datacom



Never stop thinking.

**Revision History:****2000-09-14**DS 1

---

Previous Version: MISTRAL V1.1 Preliminary Data Sheet, 08.99, DS1

---

Page (previous Version)	Page (current Version)	Subjects (major changes since last revision)
34-36	36-38	Correction: signal 'OSR' is multiplexed with signal 'CD', signal 'OST' is multiplexed with 'CTS' (was vice versa)
85	87	corrected HDLC receive address recognition table
218, 226	222, 230	Corrected location of TCD interrupt (async/bisync modes only) in registers <b>ISRO</b> and <b>IMRO</b> from bit 7 to bit 2.
-	-	removed referneces to Intel Multiplexed Mode
268	272	Chapter "Electrical Characteristics" updated with final characterization results.

For questions on technology, delivery and prices please contact the Infineon Technologies Offices in Germany or the Infineon Technologies Companies and Representatives worldwide: see our webpage at <http://www.infineon.com>

<b>Table of Contents</b>		<b>Page</b>
<b>1</b>	<b>Introduction</b> .....	18
1.1	Features .....	19
1.2	Logic Symbol .....	23
1.3	Typical Applications .....	24
1.3.1	System Integration Example .....	24
1.3.2	Serial Configuration Examples .....	25
1.4	Differences between SEROCCO-D and the ESCC Family .....	27
1.4.1	Enhancements to the ESCC Serial Core .....	27
1.4.2	Simplifications to the ESCC Serial Core .....	27
<b>2</b>	<b>Pin Descriptions</b> .....	28
2.1	Pin Diagram P-TQFP-144-10 .....	28
2.2	Pin Definitions and Functions .....	29
<b>3</b>	<b>Functional Overview</b> .....	43
3.1	Block Diagram .....	43
3.2	Serial Communication Controller (SCC) .....	44
3.2.1	Protocol Modes Overview .....	44
3.2.2	SCC FIFOs .....	44
3.2.2.1	SCC Transmit FIFO .....	45
3.2.2.2	SCC Receive FIFO .....	45
3.2.2.3	SCC FIFO Access .....	47
3.2.3	Clocking System .....	48
3.2.3.1	Clock Mode 0 (0a/0b) .....	52
3.2.3.2	Clock Mode 1 .....	53
3.2.3.3	Clock Mode 2 (2a/2b) .....	54
3.2.3.4	Clock Mode 3 (3a/3b) .....	55
3.2.3.5	Clock Mode 4 .....	56
3.2.3.6	Clock Mode 5a (Time Slot Mode) .....	57
3.2.3.7	Clock Mode 5b (Octet Sync Mode) .....	64
3.2.3.8	Clock Mode 6 (6a/6b) .....	67
3.2.3.9	Clock Mode 7 (7a/7b) .....	68
3.2.4	Baud Rate Generator (BRG) .....	69
3.2.5	Clock Recovery (DPLL) .....	69
3.2.6	SCC Timer Operation .....	72
3.2.7	SCC Serial Bus Configuration Mode .....	73
3.2.8	Serial Bus Access Procedure .....	73
3.2.9	Serial Bus Collisions and Recovery .....	73
3.2.10	Serial Bus Access Priority Scheme .....	74
3.2.11	Serial Bus Configuration Timing Modes .....	75
3.2.12	Functions Of Signal RTS in HDLC Mode .....	75
3.2.13	Data Encoding .....	75
3.2.13.1	NRZ and NRZI Encoding .....	76



<b>Table of Contents</b>		<b>Page</b>
3.2.13.2	FM0 and FM1 Encoding .....	76
3.2.13.3	Manchester Encoding .....	77
3.2.14	Modem Control Signals (RTS, CTS, CD) .....	78
3.2.14.1	RTS/CTS Handshaking .....	78
3.2.14.2	Carrier Detect (CD) Receiver Control .....	79
3.2.15	Local Loop Test Mode .....	79
3.3	Microprocessor Interface .....	80
3.4	Internal DMA Controller .....	81
3.4.1	Arbitration for Bus Control .....	81
3.4.2	Performing DMA Transfers .....	82
3.4.3	Bus Preemption .....	83
3.4.4	Ending DMA Transfers .....	83
3.5	Interrupt Architecture .....	83
3.6	General Purpose Port Pins .....	85
3.6.1	GPP Functional Description .....	85
3.6.2	GPP Interrupt Indication .....	85
<b>4</b>	<b>Detailed Protocol Description .....</b>	<b>86</b>
4.1	HDLC/SDLC Protocol Modes .....	87
4.1.1	HDLC Submodes Overview .....	87
4.1.1.1	Automode .....	87
4.1.1.2	Address Mode 2 .....	88
4.1.1.3	Address Mode 1 .....	88
4.1.1.4	Address Mode 0 .....	89
4.1.2	HDLC Receive Data Processing .....	89
4.1.3	Receive Address Handling .....	91
4.1.4	HDLC Transmit Data Processing .....	91
4.1.5	Shared Flags .....	93
4.1.6	One Bit Insertion .....	93
4.1.7	Preamble Transmission .....	93
4.1.8	CRC Generation and Checking .....	94
4.1.9	Receive Length Check Feature .....	94
4.2	Point-to-Point Protocol (PPP) Modes .....	95
4.2.1	Bit Synchronous PPP .....	95
4.2.2	Octet Synchronous PPP .....	95
4.2.3	Asynchronous PPP .....	96
4.2.4	Data Transparency in PPP Mode .....	96
4.3	Extended Transparent Mode .....	99
4.4	Asynchronous (ASYNC) Protocol Mode .....	99
4.4.1	Character Framing .....	99
4.4.2	Data Reception .....	100
4.4.2.1	Asynchronous Mode .....	100
4.4.2.2	Isochronous Mode .....	100

<b>Table of Contents</b>		<b>Page</b>
4.4.2.3	Storage of Receive Data .....	101
4.4.3	Data Transmission .....	101
4.4.4	Special Functions .....	102
4.4.4.1	Break Detection/Generation .....	102
4.4.4.2	In-band Flow Control by XON/XOFF Characters .....	102
4.4.4.3	Out-of-band Flow Control .....	104
4.5	BISYNC Protocol Mode .....	106
4.5.1	Character Framing .....	106
4.5.2	Data Reception .....	107
4.5.3	Data Transmission .....	108
4.5.4	Special Functions .....	109
4.5.4.1	Preamble Transmission .....	109
4.6	Procedural Support (Layer-2 Functions) .....	109
4.6.1	Full-Duplex LAPB/LAPD Operation .....	109
4.6.2	Half-Duplex SDLC-NRM Operation .....	115
4.6.3	Signaling System #7 (SS7) Operation .....	117
<b>5</b>	<b>Register Description .....</b>	<b>120</b>
5.1	Register Overview .....	120
5.2	Detailed Register Description .....	126
5.2.1	Global Registers .....	126
5.2.2	Channel Specific SCC Registers .....	143
5.2.3	Channel Specific DMA Registers .....	239
5.2.4	Miscellaneous Registers .....	255
<b>6</b>	<b>Programming .....</b>	<b>258</b>
6.1	Initialization .....	258
6.2	Interrupt Mode .....	258
6.2.1	Data Transmission (Interrupt Driven) .....	258
6.2.2	Data Reception (Interrupt Driven) .....	260
6.3	Internal DMA Mode .....	263
6.3.1	Data Transmission (DMA Controlled) .....	263
6.3.2	Data Reception (DMA Controlled) .....	266
6.3.3	Buffer Switched Mode .....	270
<b>7</b>	<b>Electrical Characteristics .....</b>	<b>272</b>
7.1	Absolute Maximum Ratings .....	272
7.2	Operating Range .....	272
7.3	DC Characteristics .....	273
7.4	AC Characteristics .....	274
7.5	Capacitances .....	274
7.6	Thermal Package Characteristics .....	275
7.7	Timing Diagrams .....	276
7.7.1	Microprocessor Interface Timing .....	276



<b>Table of Contents</b>		<b>Page</b>
7.7.1.1	Microprocessor Interface Clock Timing .....	276
7.7.1.2	Infineon/Intel Bus Interface Timing (Slave Access) .....	277
7.7.1.3	Motorola Bus Interface Timing (Slave Access) .....	279
7.7.1.4	Infineon/Intel Bus Interface Timing (Master Access) .....	281
7.7.1.5	Motorola Bus Interface Timing (Master Access) .....	283
7.7.1.6	Bus Arbitration Timing .....	285
7.7.2	PCM Serial Interface Timing .....	286
7.7.2.1	Clock Input Timing .....	286
7.7.2.2	Receive Cycle Timing .....	287
7.7.2.3	Transmit Cycle Timing .....	288
7.7.2.4	Clock Mode 1 Strobe Timing .....	290
7.7.2.5	Clock Mode 4 Gating Timing .....	291
7.7.2.6	Clock Mode 5 Frame Synchronisation Timing .....	292
7.7.3	Reset Timing .....	293
7.7.4	JTAG-Boundary Scan Timing .....	294
<b>8</b>	<b>Test Modes</b> .....	<b>295</b>
8.1	JTAG Boundary Scan Interface .....	295
<b>9</b>	<b>Package Outlines</b> .....	<b>300</b>

<b>List of Figures</b>		<b>Page</b>
Figure 1	Logic Symbol . . . . .	23
Figure 2	System Integration . . . . .	24
Figure 3	Point-to-Point Configuration . . . . .	25
Figure 4	Point-to-Multipoint Bus Configuration . . . . .	26
Figure 5	Multimaster Bus Configuration . . . . .	26
Figure 6	Pin Configuration P-TQFP-144-10 Package . . . . .	28
Figure 7	Block Diagram . . . . .	43
Figure 8	SCC Transmit FIFO . . . . .	45
Figure 9	SCC Receive FIFO . . . . .	46
Figure 10	XFIFO/RFIFO Word Access (Intel Mode) . . . . .	47
Figure 11	XFIFO/RFIFO Word Access (Motorola Mode) . . . . .	47
Figure 12	Clock Supply Overview . . . . .	51
Figure 13	Clock Mode 0a/0b Configuration . . . . .	52
Figure 14	Clock Mode 1 Configuration . . . . .	53
Figure 15	Clock Mode 2a/2b Configuration . . . . .	54
Figure 16	Clock Mode 3a/3b Configuration . . . . .	55
Figure 17	Clock Mode 4 Configuration . . . . .	56
Figure 18	Selecting one time-slot of programmable delay and width . . . . .	58
Figure 19	Selecting one or more time-slots of 8-bit width . . . . .	60
Figure 20	Clock Mode 5a Configuration . . . . .	61
Figure 21	Clock Mode 5a "Continuous Mode" . . . . .	62
Figure 22	Clock Mode 5a "Non Continuous Mode" . . . . .	63
Figure 23	Selecting one or more octet wide time-slots . . . . .	65
Figure 24	Clock Mode 5b Configuration . . . . .	66
Figure 25	Clock Mode 6a/6b Configuration . . . . .	67
Figure 26	Clock Mode 7a/7b Configuration . . . . .	68
Figure 27	DPLL Algorithm (NRZ and NRZI Encoding, Phase Shift Enabled) . . . . .	71
Figure 28	DPLL Algorithm (NRZ and NRZI Encoding, Phase Shift Disabled) . . . . .	71
Figure 29	DPLL Algorithm for FM0, FM1 and Manchester Encoding . . . . .	72
Figure 30	Request-to-Send in Bus Operation . . . . .	75
Figure 31	NRZ and NRZI Data Encoding . . . . .	76
Figure 32	FM0 and FM1 Data Encoding . . . . .	77
Figure 33	Manchester Data Encoding . . . . .	77
Figure 34	RTS/CTS Handshaking . . . . .	79
Figure 35	SCC Test Loop . . . . .	80
Figure 36	SEROCCO-D requests and gets the bus . . . . .	82
Figure 37	Un-interrupted Series of 32 DMA Bus Cycles . . . . .	82
Figure 38	Bus Preemption and Re-gain of Bus Control . . . . .	83
Figure 39	SEROCCO-D requests and gets the bus . . . . .	83
Figure 40	Interrupt Status Registers . . . . .	84
Figure 41	HDLC Receive Data Processing in 16 bit Automode . . . . .	89
Figure 42	HDLC Receive Data Processing in 8 bit Automode . . . . .	89

<b>List of Figures</b>	<b>Page</b>
Figure 43	HDLC Receive Data Processing in Address Mode 2 (16 bit) . . . . . 90
Figure 44	HDLC Receive Data Processing in Address Mode 2 (8 bit) . . . . . 90
Figure 45	HDLC Receive Data Processing in Address Mode 1 . . . . . 90
Figure 46	HDLC Receive Data Processing in Address Mode 0 . . . . . 91
Figure 47	SCC Transmit Data Flow (HDLC Modes) . . . . . 92
Figure 48	PPP Mapping/Unmapping Example . . . . . 98
Figure 49	Asynchronous Character Frame . . . . . 100
Figure 50	Out-of-Band DTE-DTE Bi-directional Flow Control . . . . . 105
Figure 51	Out-of-Band DTE-DCE Bi-directional Flow Control . . . . . 106
Figure 52	BISYNC Message Format . . . . . 107
Figure 53	Processing of Received Frames in Auto Mode . . . . . 111
Figure 54	Timer Procedure/Poll Cycle . . . . . 113
Figure 55	Transmission/Reception of I-Frames and Flow Control . . . . . 114
Figure 56	Flow Control: Reception of S-Commands and Protocol Errors . . . . . 114
Figure 57	No Data to Send: Data Reception/Transmission . . . . . 117
Figure 58	Data Transmission (without error), Data Transmission (with error) . . 117
Figure 59	Interrupt Driven Data Transmission (Flow Diagram) . . . . . 260
Figure 60	Interrupt Driven Data Reception (Flow Diagram) . . . . . 262
Figure 61	DMA Transmit (Single Buffer per Packet) . . . . . 264
Figure 62	Fragmented DMA Transmission (Multiple Buffers per Packet) . . . . . 265
Figure 63	DMA Controlled Data Transmission (Flow Diagram) . . . . . 266
Figure 64	DMA Receive (Single Buffer per Packet) . . . . . 267
Figure 65	Fragmented Reception per DMA (Example) . . . . . 268
Figure 66	Fragmented Reception Sequence (Example) . . . . . 269
Figure 67	DMA Controlled Data Reception (Flow Diagram) . . . . . 270
Figure 68	Input/Output Waveform for AC Tests . . . . . 274
Figure 69	Microprocessor Interface Clock Timing . . . . . 276
Figure 70	Infineon/Intel Read Cycle Timing (Slave Access) . . . . . 277
Figure 71	Infineon/Intel Write Cycle Timing (Slave Access) . . . . . 277
Figure 72	Motorola Read Cycle Timing (Slave Access) . . . . . 279
Figure 73	Motorola Write Cycle Timing (Slave Access) . . . . . 279
Figure 74	Infineon/Intel Read Cycle Timing (Master Access) . . . . . 281
Figure 75	Infineon/Intel Write Cycle Timing (Master Access) . . . . . 282
Figure 76	Motorola Read Cycle Timing (Master Access) . . . . . 283
Figure 77	Motorola Write Cycle Timing (Master Access) . . . . . 284
Figure 78	Bus Arbitration Timing . . . . . 285
Figure 79	Clock Input Timing . . . . . 286
Figure 80	Receive Cycle Timing . . . . . 287
Figure 81	Transmit Cycle Timing . . . . . 288
Figure 82	Clock Mode 1 Strobe Timing . . . . . 290
Figure 83	Clock Mode 4 Receive Gating Timing . . . . . 291
Figure 84	Clock Mode 4 Transmit Gating Timing . . . . . 291

**List of Figures**

**Page**

Figure 85	Clock Mode 5 Frame Synchronisation Timing . . . . .	292
Figure 86	Reset Timing . . . . .	293
Figure 87	JTAG-Boundary Scan Timing . . . . .	294
Figure 88	Block Diagram of Test Access Port and Boundary Scan Unit . . . . .	295

<b>List of Tables</b>		<b>Page</b>
Table 1	Microprocessor Bus Interface .....	29
Table 2	Bus Arbitration .....	34
Table 3	Serial Port Pins .....	35
Table 4	General Purpose Pins .....	39
Table 5	Test Interface Pins .....	40
Table 6	Power Pins .....	41
Table 7	Overview of Clock Modes .....	48
Table 8	Clock Modes of the SCCs .....	49
Table 9	BRRL/BRRH Register and Bit-Fields .....	69
Table 10	Data Bus Access 16-bit Intel Mode .....	80
Table 11	Data Bus Access 16-bit Motorola Mode .....	81
Table 12	Protocol Mode Overview .....	86
Table 13	Address Comparison Overview .....	87
Table 14	Error Handling .....	115
Table 15	Register Overview .....	120
Table 16	Status Information after RME interrupt .....	261
Table 17	DMA Terminology .....	263
Table 18	Capacitances	
	TA = 25 °C; VDD3 = 3.3 V ± 0.3 V, VSS = 0 V .....	274
Table 19	Thermal Package Characteristics P-TQFP-144-10 .....	275
Table 20	Microprocessor Interface Clock Timing .....	276
Table 21	Infineon/Intel Bus Interface Timing (Slave Access) .....	278
Table 22	Motorola Bus Interface Timing (Slave Access) .....	280
Table 23	Infineon/Intel Bus Interface Timing (Master Access) .....	282
Table 24	Motorola Bus Interface Timing (Master Access) .....	284
Table 25	Bus Arbitration Timing .....	285
Table 26	Clock Input Timing .....	286
Table 27	Receive Cycle Timing .....	287
Table 28	Transmit Cycle Timing .....	289
Table 29	Clock Mode 1 Strobe Timing .....	290
Table 30	Clock Mode 4 Gating Timing .....	291
Table 31	Clock Mode 5 Frame Synchronisation Timing .....	292
Table 32	Reset Timing .....	293
Table 33	JTAG-Boundary Scan Timing .....	294
Table 34	Boundary Scan Sequence of SEROCCO-D .....	296
Table 35	Boundary Scan Test Modes .....	299

<b>List of Registers</b>		<b>Page</b>
Register 1	GCMDR .....	126
Register 2	GMODE .....	127
Register 3	DBSR .....	130
Register 4	GSTAR .....	131
Register 5	GPDIR .....	133
Register 6	GPDAT .....	134
Register 7	GPIM .....	135
Register 8	GPIS .....	136
Register 9	DCMDR .....	137
Register 10	DMODE .....	139
Register 11	DISR .....	140
Register 12	DIMR .....	142
Register 13	FIFOL .....	143
Register 14	FIFOH .....	143
Register 15	STARL .....	145
Register 16	STARH .....	145
Register 17	CMDRL .....	150
Register 18	CMDRH .....	150
Register 19	CCR0L .....	155
Register 20	CCR0H .....	155
Register 21	CCR1L .....	159
Register 22	CCR1H .....	159
Register 23	CCR2L .....	164
Register 24	CCR2H .....	164
Register 25	CCR3L .....	171
Register 26	CCR3H .....	171
Register 27	PREAMB .....	179
Register 28	TOLEN .....	180
Register 29	ACCM0 .....	181
Register 30	ACCM1 .....	181
Register 31	ACCM2 .....	182
Register 32	ACCM3 .....	182
Register 33	UDAC0 .....	184
Register 34	UDAC1 .....	184
Register 35	UDAC2 .....	185
Register 36	UDAC3 .....	185
Register 37	T TSA0 .....	187
Register 38	T TSA1 .....	187
Register 39	T TSA2 .....	188
Register 40	T TSA3 .....	188
Register 41	R TSA0 .....	190
Register 42	R TSA1 .....	190



<b>List of Registers</b>		<b>Page</b>
Register 43	RTSA2 .....	191
Register 44	RTSA3 .....	191
Register 45	PCMTX0 .....	193
Register 46	PCMTX1 .....	193
Register 47	PCMTX2 .....	194
Register 48	PCMTX3 .....	194
Register 49	PCMRX0 .....	196
Register 50	PCMRX1 .....	196
Register 51	PCMRX2 .....	197
Register 52	PCMRX3 .....	197
Register 53	BRRL .....	199
Register 54	BRRH .....	199
Register 55	TIMR0 .....	201
Register 56	TIMR1 .....	201
Register 57	TIMR2 .....	202
Register 58	TIMR3 .....	202
Register 59	XAD1 .....	205
Register 60	XAD2 .....	205
Register 61	RAL1 .....	207
Register 62	RAH1 .....	207
Register 63	RAL2 .....	208
Register 64	RAH2 .....	208
Register 65	AMRAL1 .....	210
Register 66	AMRAH1 .....	210
Register 67	AMRAL2 .....	211
Register 68	AMRAH2 .....	211
Register 69	RLCRL .....	213
Register 70	RLCRH .....	213
Register 71	XON .....	215
Register 72	XOFF .....	215
Register 73	MXON .....	217
Register 74	MXOFF .....	217
Register 75	TCR .....	219
Register 76	TICR .....	220
Register 77	ISR0 .....	222
Register 78	ISR1 .....	222
Register 79	ISR2 .....	223
Register 80	IMR0 .....	230
Register 81	IMR1 .....	230
Register 82	IMR2 .....	231
Register 83	RSTA .....	233
Register 84	SYNCL .....	237

<b>List of Registers</b>		<b>Page</b>
Register 85	SYNCH . . . . .	237
Register 86	TBADDR1L . . . . .	239
Register 87	TBADDR1M . . . . .	239
Register 88	TBADDR1H . . . . .	240
Register 89	TBADDR2L . . . . .	241
Register 90	TBADDR2M . . . . .	241
Register 91	TBADDR2H . . . . .	242
Register 92	XBC1L . . . . .	243
Register 93	XBC1H . . . . .	243
Register 94	XBC2L . . . . .	245
Register 95	XBC2H . . . . .	245
Register 96	RBADDR1L . . . . .	247
Register 97	RBADDR1M . . . . .	247
Register 98	RBADDR1H . . . . .	248
Register 99	RBADDR2L . . . . .	249
Register 100	RBADDR2M . . . . .	249
Register 101	RBADDR2H . . . . .	250
Register 102	RMBSL . . . . .	251
Register 103	RMBSH . . . . .	251
Register 104	RBCL . . . . .	253
Register 105	RBCH . . . . .	253
Register 106	VER0 . . . . .	255
Register 107	VER1 . . . . .	255
Register 108	VER2 . . . . .	256
Register 109	VER3 . . . . .	256

## Preface

The 2 Channel Serial Optimized Communication Controller with DMA PEB 20542 (SEROCCO-D) is a Protocol Controller for a wide range of data communication and telecommunication applications. This document provides complete reference information on hardware and software related issues as well as on general operation.

### Organization of this Document

This Data Sheet is divided into 9 chapters. It is organized as follows:

- **Chapter 1, Introduction**  
Gives a general description of the product, lists the key features, and presents some typical applications.
- **Chapter 2, Pin Descriptions**  
Lists pin locations with associated signals, categorizes signals according to function, and describes signals.
- **Chapter 3, Functional Overview**  
This chapter provides detailed descriptions of all SEROCCO-D internal functional blocks.
- **Chapter 4, Detailed Protocol Description**  
Gives a detailed description of all protocols supported by the serial communication controllers SCCs.
- **Chapter 5, Register Description**  
Gives a detailed description of all SEROCCO-D on chip registers.
- **Chapter 6, Programming**  
Provides programming help for SEROCCO-D initialization procedure and operation.
- **Chapter 7, Electrical Characteristics**  
Gives a detailed description of all electrical DC and AC characteristics and provides timing diagrams and values for all interfaces.
- **Chapter 8, Test Modes**  
Gives a detailed description of the JTAG boundary scan unit.
- **Chapter 9, Package Outlines**

## Your Comments

We welcome your comments on this document. We are continuously trying improving our documentation. Please send your remarks and suggestions by e-mail to

sc.docu\_comments@infineon.com

Please provide in the *subject* of your e-mail:

device name (SEROCCO-D), device number (PEB 20542, PEF 20542), device version (Version 1.2),

and in the *body* of your e-mail:

document type (Data Sheet), issue date (2000-09-14) and document revision number (DS 1).

## 1 Introduction

The SEROCCO-D is a DMA Integrated Serial Communication Controller with two independent serial channels<sup>1)</sup>. The serial channels are derived from updated protocol logic of the ESCC and DSCC4 device family providing a large set of protocol support and variety in serial interface configuration. This allows easy integration to different environments and applications.

A generic 8- or 16-bit demultiplexed master/slave interface provides fast device access with low bus utilization and easy software handshaking. The internal DMA controller is optimized for a minimum CPU intervention. Different control mechanisms allow easy software development well adapted to the needs of special applications (e.g. frame/packet oriented and continuous transmission/reception).

Large on-chip FIFOs of 64 byte capacity per port and direction in combination with enhanced threshold control mechanisms allow decoupling of traffic requirements on host bus and serial interfaces with little exception probabilities such as data underruns or overflows.

Each of the two Serial Communication Controllers (SCC) contains an independent Baud Rate Generator, DPLL and programmable protocol processing (HDLC, PPP, ASYNC and BISYNC). Data rates of up to 16 Mbit/s (HDLC, PPP, bit transparent) and 2 Mbit/s (DPLL assisted modes) are supported. The channels can also handle a large set of layer-2 protocol functions (LAPD, SS7) reducing bus and host CPU load. Two channel specific timers are provided to support protocol functions.

---

<sup>1)</sup> The serial channels are also called 'ports' or 'cores' depending on the context.

## 2 Channel Serial Optimized Communication Controller with DMA SEROCCO-D

PEB 20542  
PEF 20542

Version 1.2

CMOS

### 1.1 Features

#### Serial communication controllers (SCCs)

- Two independent channels
- Full duplex data rates on each channel of up to 16 Mbit/s sync - 2 Mbit/s with DPLL
- 64 Bytes deep receive FIFO per SCC
- 64 Bytes deep transmit FIFO per SCC

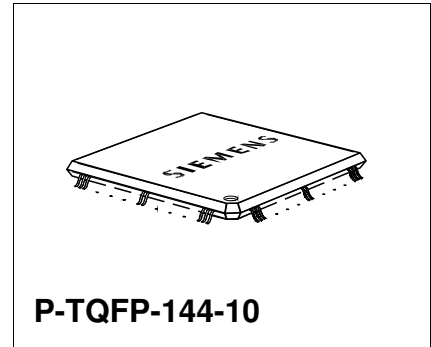

#### Serial Interface

- On-chip clock generation or external clock sources
- On-chip DPLLs for clock recovery
- Baud rate generator
- Clock gating signals
- Clock gapping capability
- Programmable time-slot capability for connection to TDM interfaces (e.g. T1, E1)
- NRZ, NRZI, FM and Manchester data encoding
- Optional data flow control using modem control lines ( $\overline{RTS}$ ,  $\overline{CTS}$ , CD)
- Support of bus configuration by collision detection and resolution

#### Bit Processor Functions

- HDLC/SDLC Protocol Modes
  - Automatic flag detection and transmission
  - Shared opening and closing flag
  - Generation of interframe-time fill '1's or flags
  - Detection of receive line status
  - Zero bit insertion and deletion

Type	Package
PEB 20542, PEF 20542	P-TQFP-144-10



- CRC generation and checking (CRC-CCITT or CRC-32)
- Transparent CRC option per channel and/or per frame
- Programmable Preamble (8 bit) with selectable repetition rate
- Error detection (abort, long frame, CRC error, short frames)
- Bit Synchronous PPP Mode
  - Bit oriented transmission of HDLC frame (flag, data, CRC, flag)
  - Zero bit insertion/deletion
  - 15 consecutive '1' bits abort sequence
- Octet Synchronous PPP Mode
  - Octet oriented transmission of HDLC frame (flag, data, CRC, flag)
  - Programmable character map of 32 hard-wired characters (00<sub>H</sub>-1F<sub>H</sub>)
  - Four programmable characters for additional mapping
  - Insertion/deletion of control-escape character (7D<sub>H</sub>) for mapped characters
- Asynchronous PPP Mode
  - Character oriented transmission of HDLC frame (flag, data, CRC, flag)
  - Start/stop bit framing of single character
  - Programmable character map of 32 hard-wired characters (00<sub>H</sub>-1F<sub>H</sub>)
  - Four programmable characters for additional mapping
  - Insertion/deletion of control-escape character (7D<sub>H</sub>) for mapped characters
- Asynchronous (ASYNC) Protocol Mode
  - Selectable character length (5 to 8 bits)
  - Even, odd, forced or no parity generation/checking
  - 1 or 2 stop bits
  - Break detection/generation
  - In-band flow control by XON/XOFF
  - Immediate character insertion
  - Termination character detection for end of block identification
  - Time out detection
  - Error detection (parity error, framing error)
- BISYNC Protocol Mode
  - Programmable 6/8 bit SYN pattern (MONOSYNC)
  - Programmable 12/16 bit SYN pattern (BISYNC)
  - Selectable character length (5 to 8 bits)
  - Even, odd, forced or no parity generation/checking
  - Generation of interframe-time fill '1's or SYN characters
  - CRC generation (CRC-16 or CRC-CCITT)
  - Transparent CRC option per channel and/or per frame
  - Programmable Preamble (8 bit) with selectable repetition rate
  - Termination character detection for end of block identification
  - Error detection (parity error, framing error)
- Extended Transparent Mode
  - Fully bit transparent (no framing, no bit manipulation)
  - Octet-aligned transmission and reception

- Protocol and Mode Independent
  - Data bit inversion
  - Data overflow and underrun detection
  - Timer

### Protocol Support

- Address Recognition Modes
  - No address recognition (Address Mode 0)
  - 8-bit (high byte) address recognition (Address Mode 1)
  - 8-bit (low byte) or 16-bit (high and low byte) address recognition (Address Mode 2)
- HDLC Automode
  - 8-bit or 16-bit address generation/recognition
  - Support of LAPB/LAPD
  - Automatic handling of S- and I-frames
  - Automatic processing of control byte(s)
  - Modulo-8 or modulo-128 operation
  - Programmable time-out and retry conditions
  - SDLC Normal Response Mode (NRM) operation for slave
- Signaling System #7 (SS7) support
  - Detection of FISUs, MSUs and LSSUs
  - Unchanged Fill-In Signaling Units (FISUs) not forwarded
  - Automatic generation of FISUs in transmit direction (incl. sequence number)
  - Counting of errored signaling units

### Integrated DMA Controller

- 4 independent DMA channels
- Optimized for minimum CPU intervention
- Efficient block-oriented data transfer
- Bus preemption
- Fragmented transmission/reception of data packets from/into multiple buffers
- Switched-Buffer mode for seamless update of buffer base address and size
- 24-bit addressable memory range
- Optional  $\overline{DTACK}/\overline{READY}$  controlled cycles

### Microprocessor Interface

- 8/16-bit bus interface
- De-multiplexed address/data bus
- Intel/Motorola style
- Asynchronous interface
- Maskable interrupts for each channel

## General Purpose Port (GPP) Pins

### General

- 3.3V power supply with 5V tolerant inputs
- Low power consumption
- Power safe features
- P-TQFP-144-10 Package (Thermal Resistance:  $R_{JA} = 39K/W$ )

## 1.2 Logic Symbol

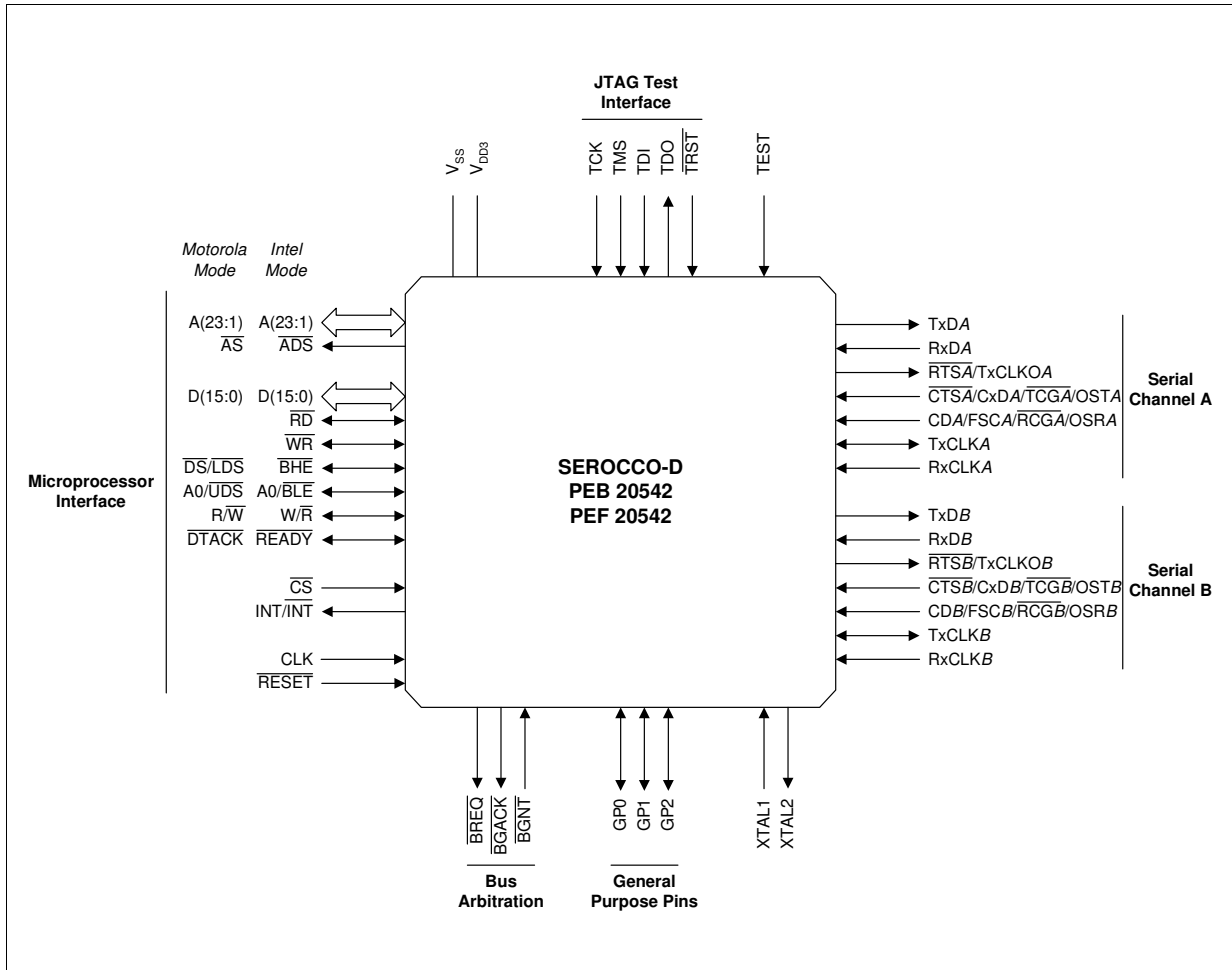

Figure 1 Logic Symbol

### 1.3 Typical Applications

SEROCCO-D devices can be used in LAN-WAN inter-networking applications such as Routers, Switches and Trunk cards and support the common V.35, ISDN BRI (S/T) and RFC1662 standards. Its new features provide powerful hardware and software interfaces to develop high performance systems.

#### 1.3.1 System Integration Example

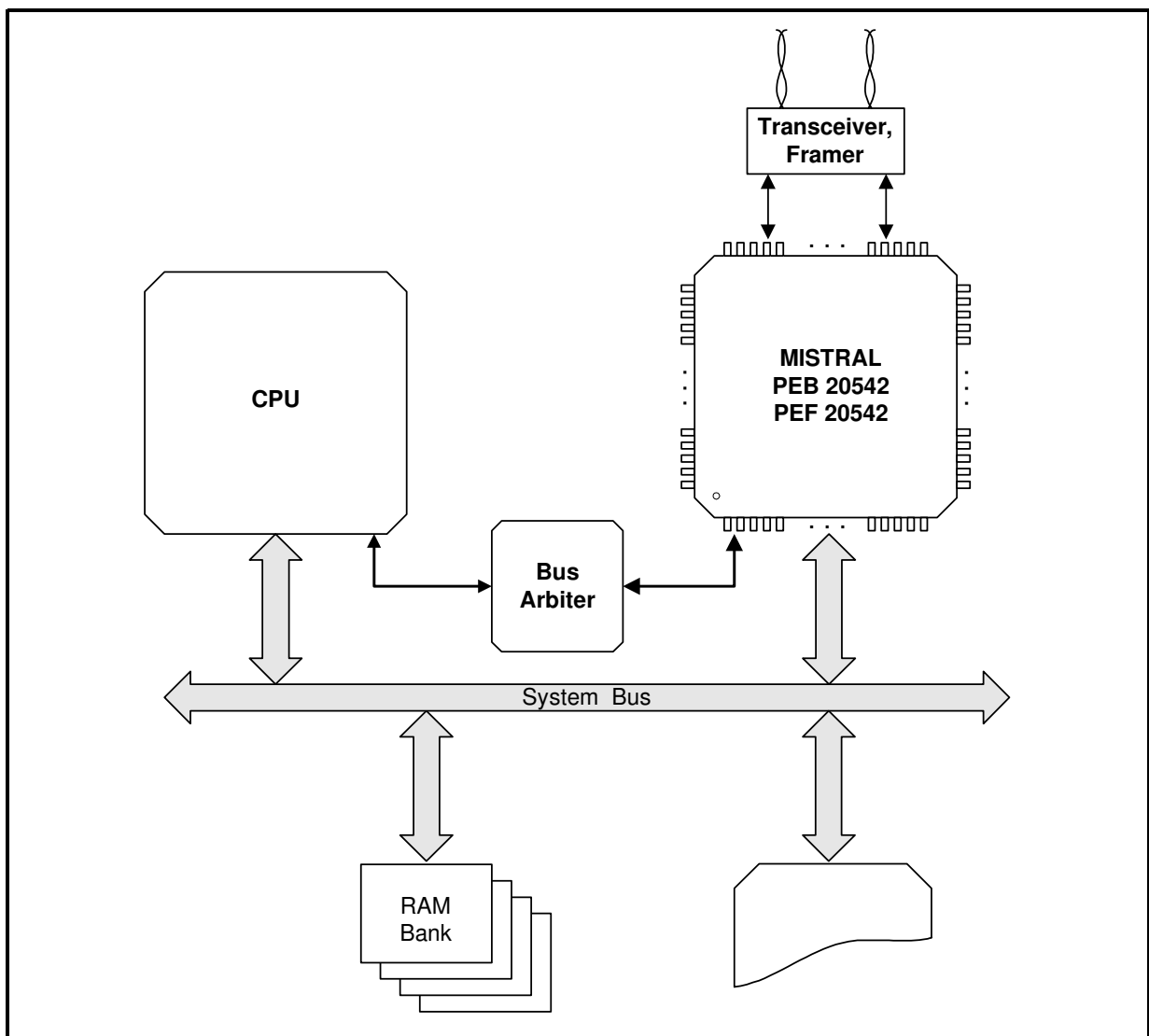
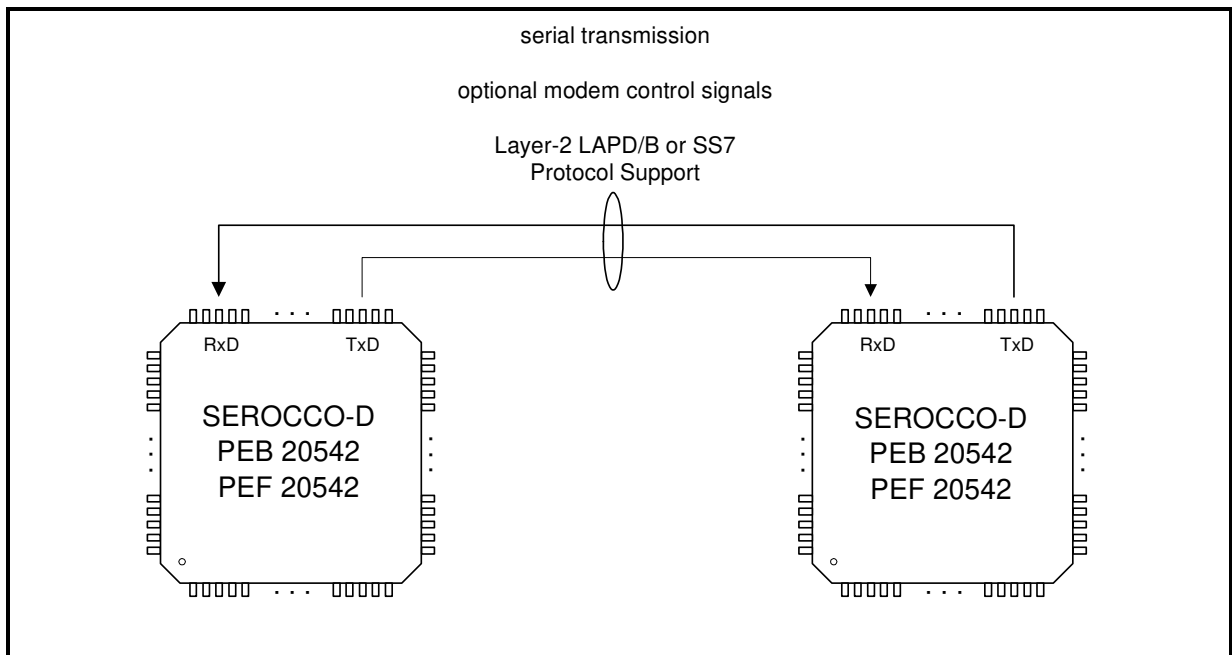

Figure 2 System Integration

### 1.3.2 Serial Configuration Examples

SEROCCO-D supports a variety of serial configurations at Layer-1 and Layer-2 level. The outstanding variety of clock modes supporting a large number of combinations of external and internal clock sources allows easy integration in application environments.



**Figure 3 Point-to-Point Configuration**